

Beam Simulation Group Plans

Laura Fields and Paola Sala

24 September 2015

Outline

- ❖ Purpose of our group
- ❖ Near term plans

Purpose of Our Group

- ❖ Collaborate with Beam Interface WG and Beam Optimization Task Force to build tools needed for and to execute beam optimization and other beam studies
- ❖ Provide beam flux simulations and systematic uncertainties that are the starting point of beam-based physics studies

Our group's responsibility is DUNE's beam simulation software for physics studies, but we will work closely with the MARS team (which develops the beam simulation used for LBNF radiological studies)

Near Term Plans

- ❖ An urgent need of the Near Detector Optimization Task Force is a priori flux uncertainties and bin-to-bin correlations (inputs to near detector fits):
 - ❖ There is currently no good estimate of these for DUNE

Zeroth Order Plan:

Borrow NuMI Uncertainties

Specifically, MINERvA's

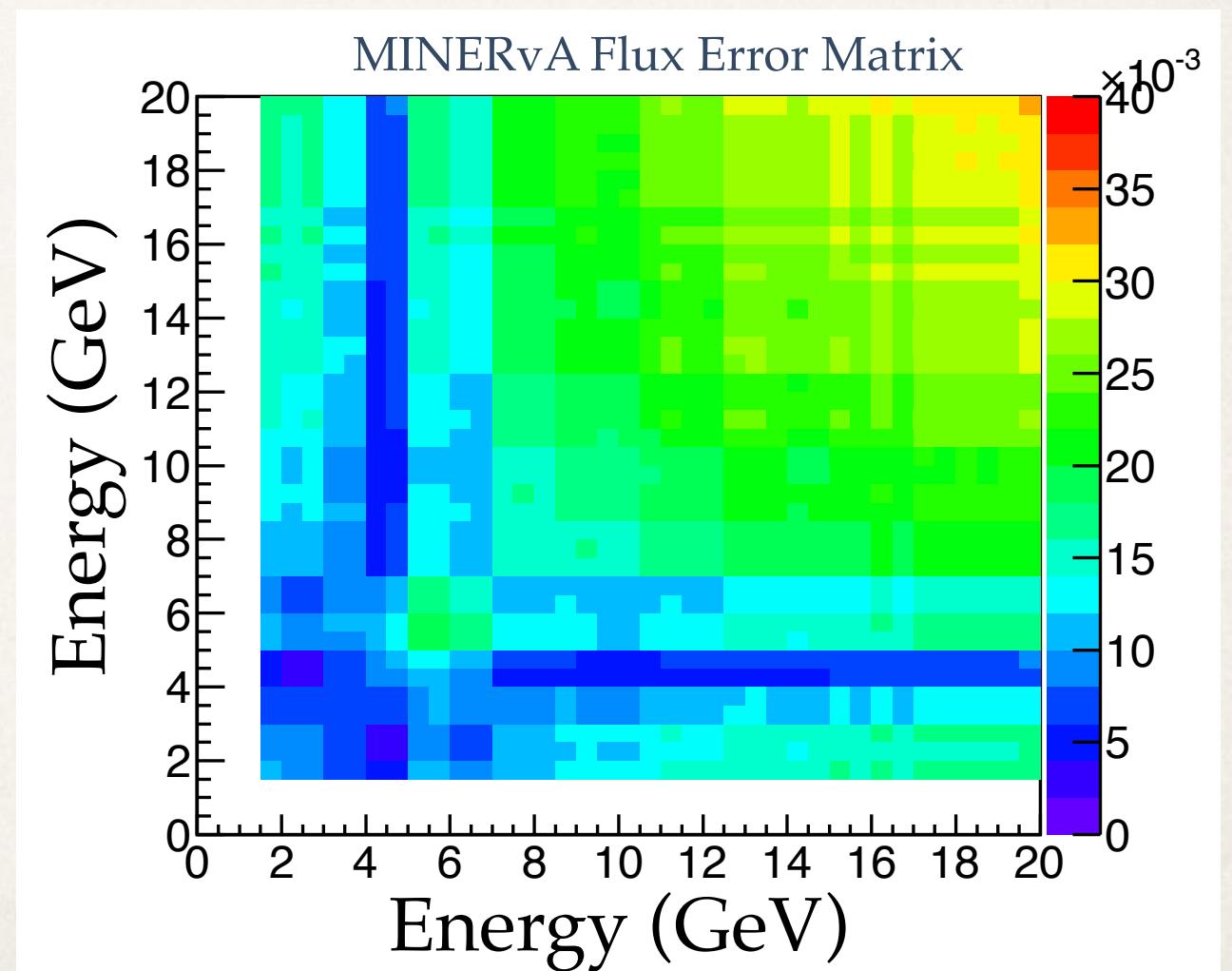

Near Term Plans

- ❖ Next step in producing flux uncertainties and correlations: use external data constraints, leaning heavily on infrastructure already developed by NuMI:

A. Bashyal & H. Schellman of OSU will apply MINERvA's procedure to DUNE

Others welcome (especially those familiar with alternative methods e.g. BMPT parameterization)

Flux event record

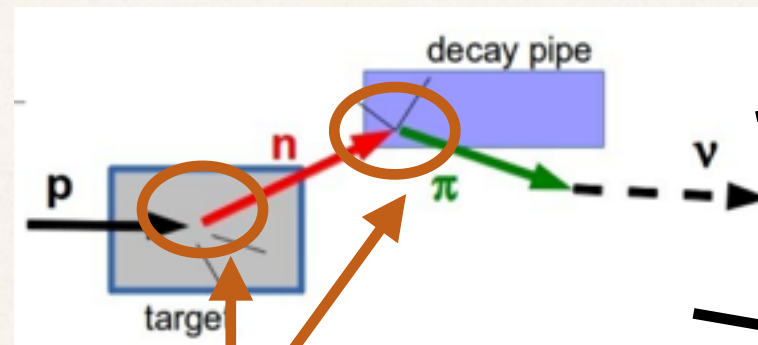

Each interaction in the ancestry list is adjusted and an uncertainty assigned using external data constraints (or very large uncertainty assumptions where data is unavailable)

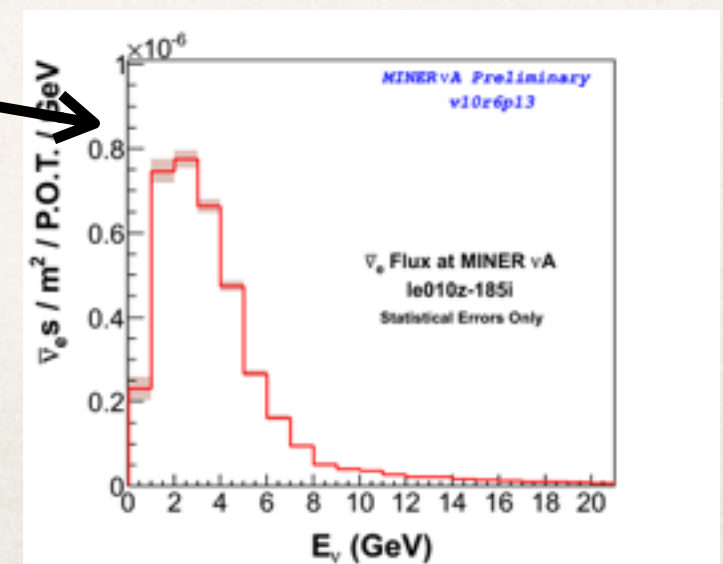
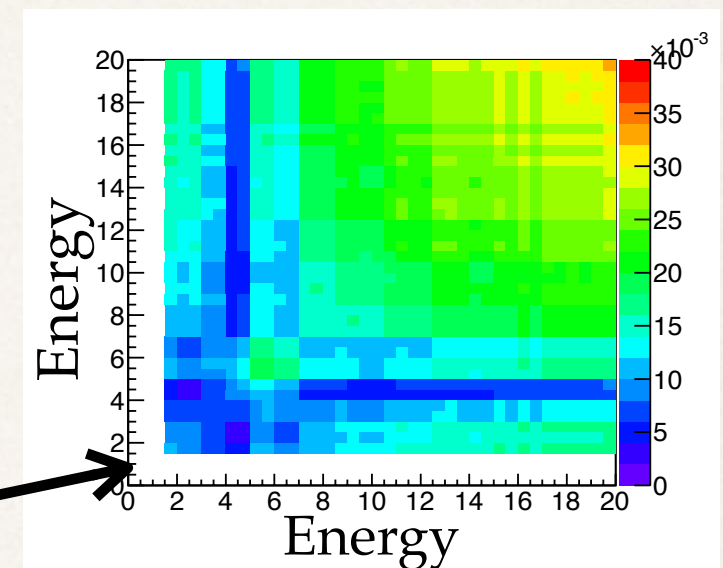

Near Term Plans

- ❖ Another important component in understanding systematic uncertainties: the ability to run with many different hadron production models:

P. Sala plans to add a full-FLUKA option to the DUNE beam simulation

Important for understanding flux uncertainties; also an important cross-check of GEANT4 implementation of geometry

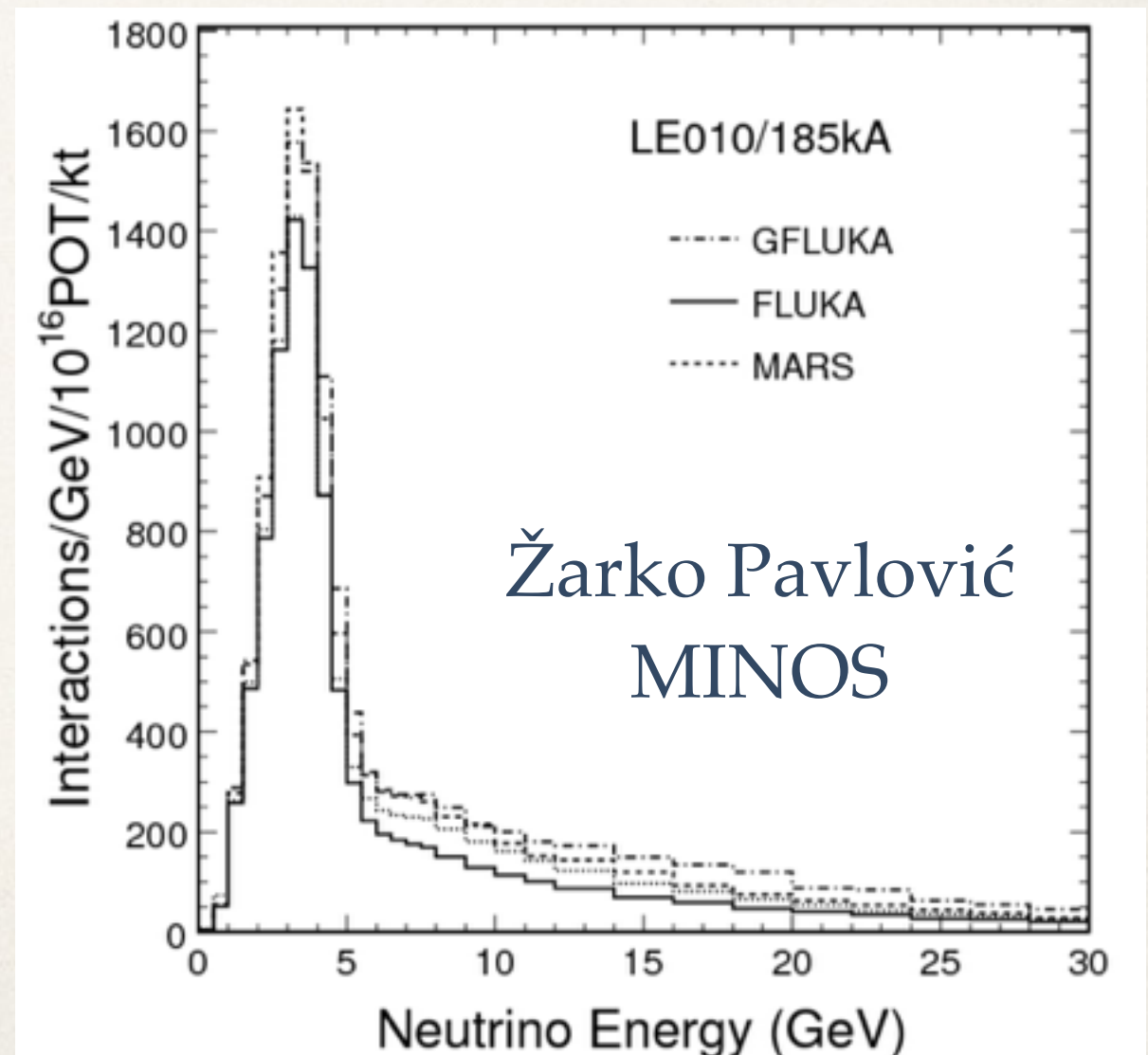

Near Term Plans

- ❖ Another goal of the group: facilitate beam design optimization

P. LeBrun has implemented an option with three (or more!) configurable horns

**More options to come:
sphere-array target?
target wings?
parabolic horn shapes**

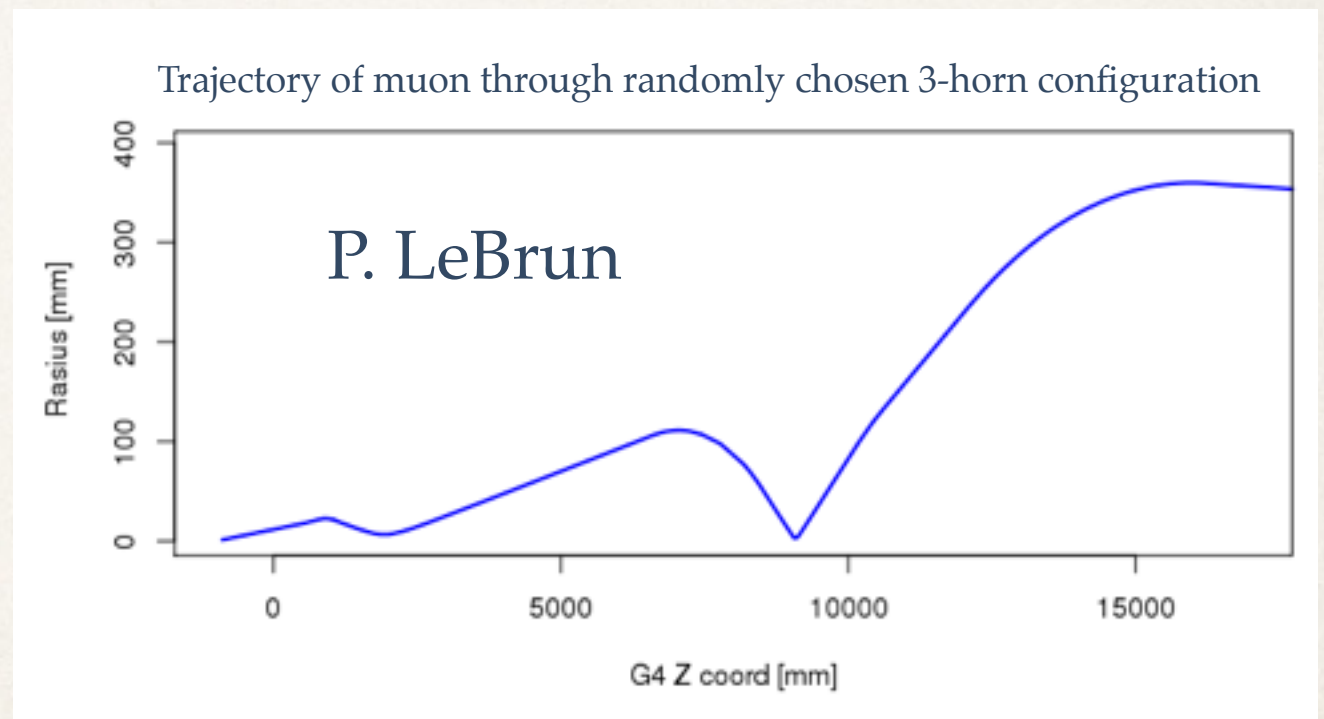

Near Term Plans

- ❖ Another high priority activity: Fast MC Interface

All DUNE Fast MC studies begin with a beam simulation

Many other physics / reco efforts (e.g. FD reconstruction) piggyback on Fast MC files

We need help developing this interface

Coming soon: Flux histogram -> Flux driver transition

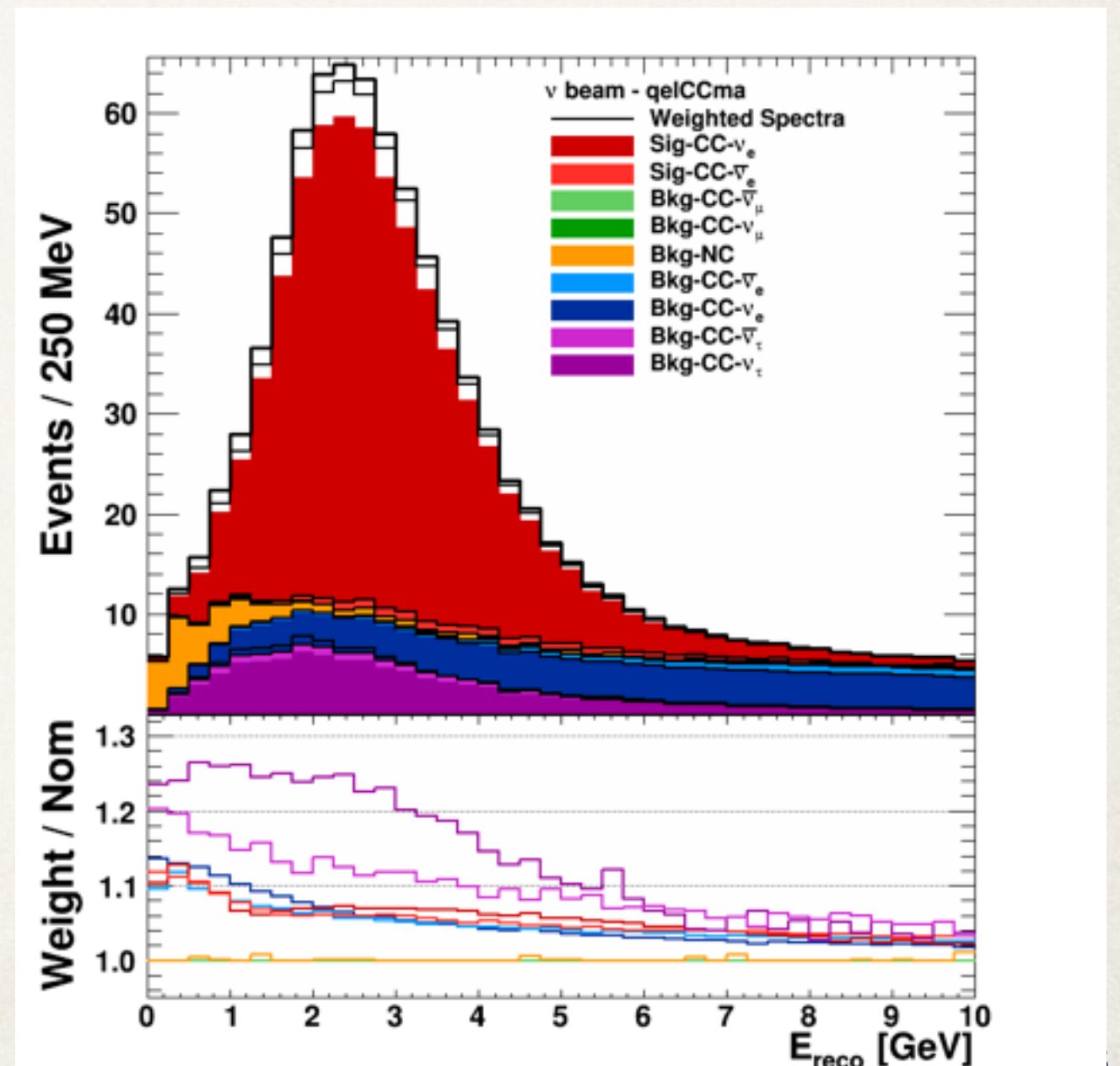

Near Term Plans

- ❖ Another active project: HA, instrumentation studies

P. LeBrun has also implemented a sculpted hadron absorber design in Geant4

Basic first steps towards implementation of hadron and muon monitor simulations have been taken

Much more work needed before we have a full simulation of monitors and an understanding of their impact on physics.

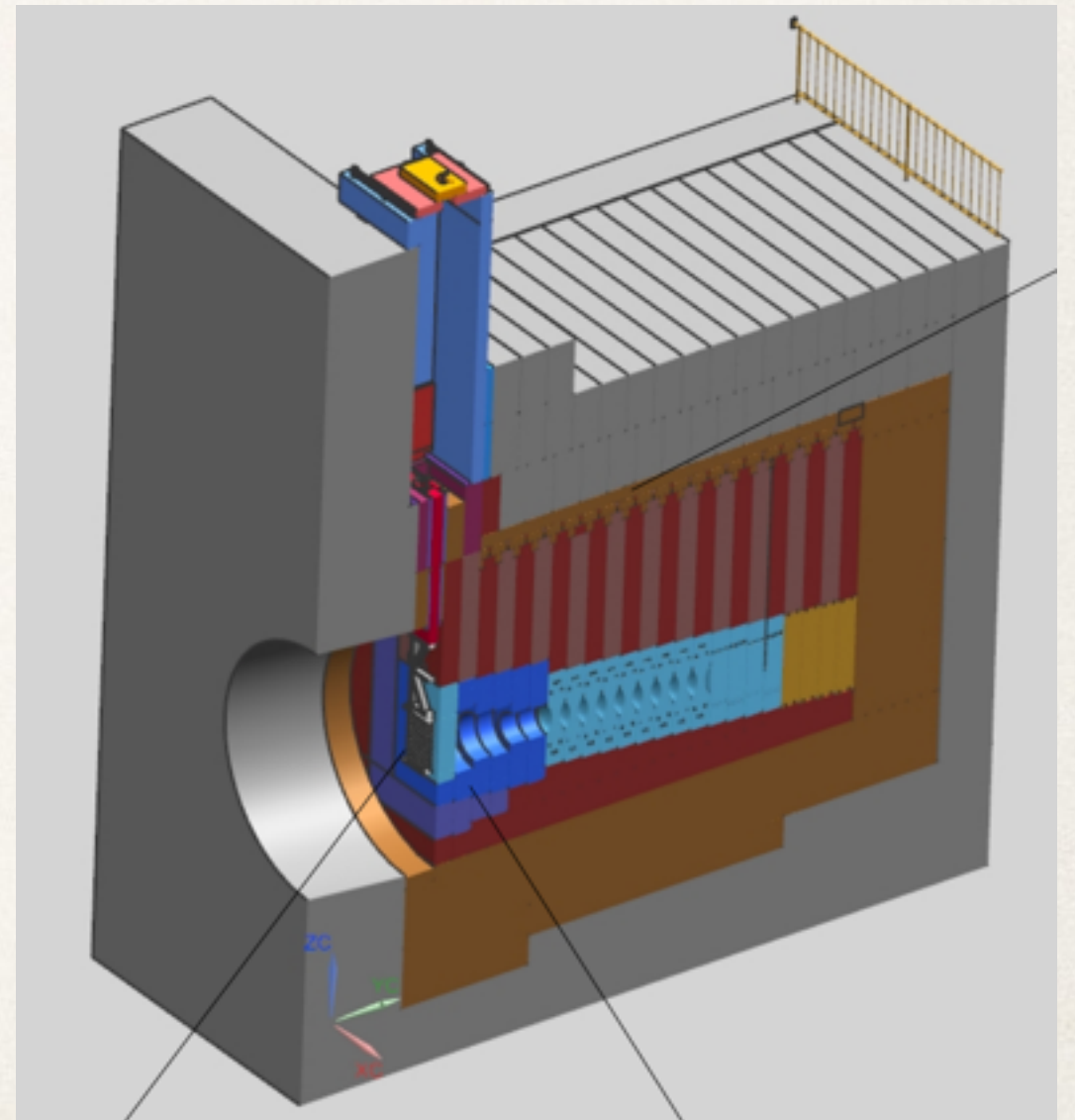

Near Term Plans

- ❖ Small studies (executable by newish students)
 - ❖ Downstream high-Z target
 - ❖ Off-axis angles in optimized beam
 - ❖ Parabolic version of optimized horn
 - ❖ Update & refinement of optimization metric
 - ❖ Fast estimator of CP & MH sensitivity -> may be of use outside of beam group
 - ❖ Estimates of focusing uncertainty and alignment tolerances for optimized beams

The End