

ProtoDUNE Cryostat Feedthrough Considerations

Thomas Kutter, LSU

Timeline and Open Issues

Engineering meeting next week at CERN to **finalize** cryostat design and feed-throughs

Loosely defined components which need to be better defined:

- Beam window positions + dimensions
- Beam particle tagger feed-throughs
- Slow control feed-throughs

- Laser calibration feed-throughs
 - To be addressed during workshop (Igor Kreslo)
- Spare feed-throughs
 - How many, dimensions, locations ?
- ...

Pion Containment

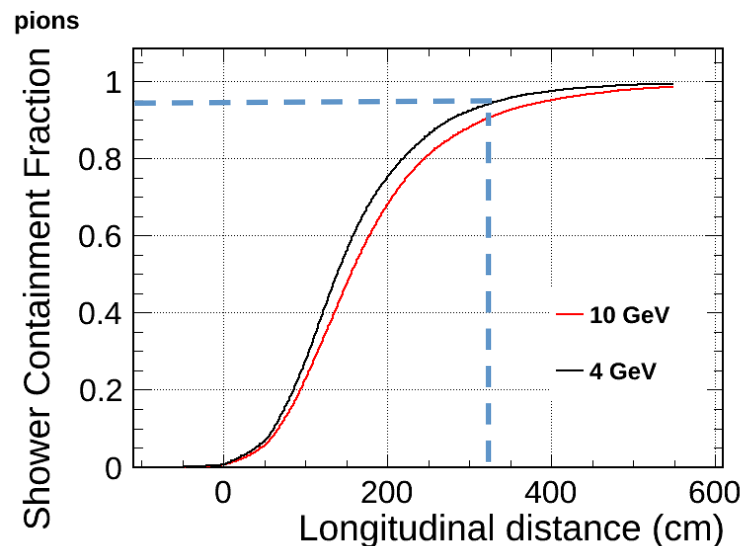
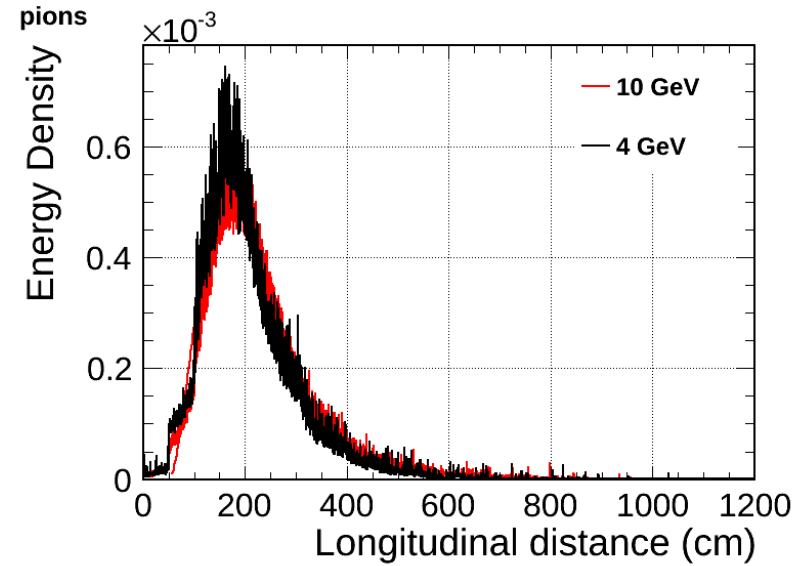
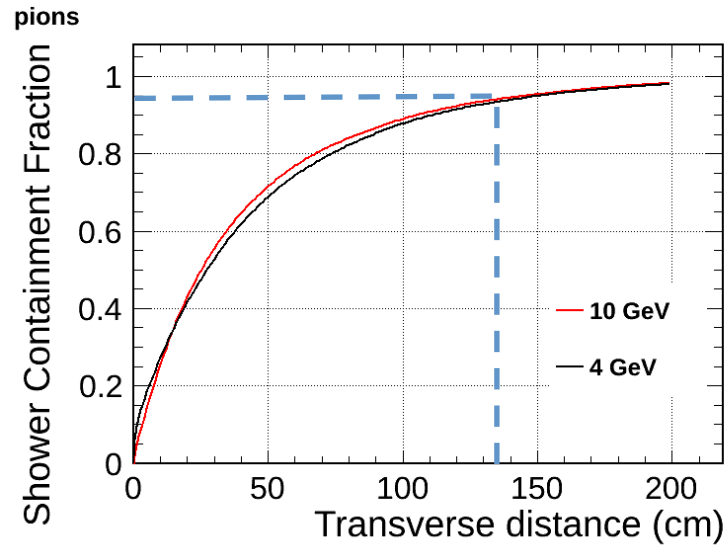

95 % containment envelope

Transverse: 1.35 m

Longitudinal: 3.2 m

\sim 99 % containment envelope

Transverse: 2.1 m

Longitudinal: 5.3 m

Horizontal angle [°]	Off-set [cm]
3	145
6.5	15
10	-70

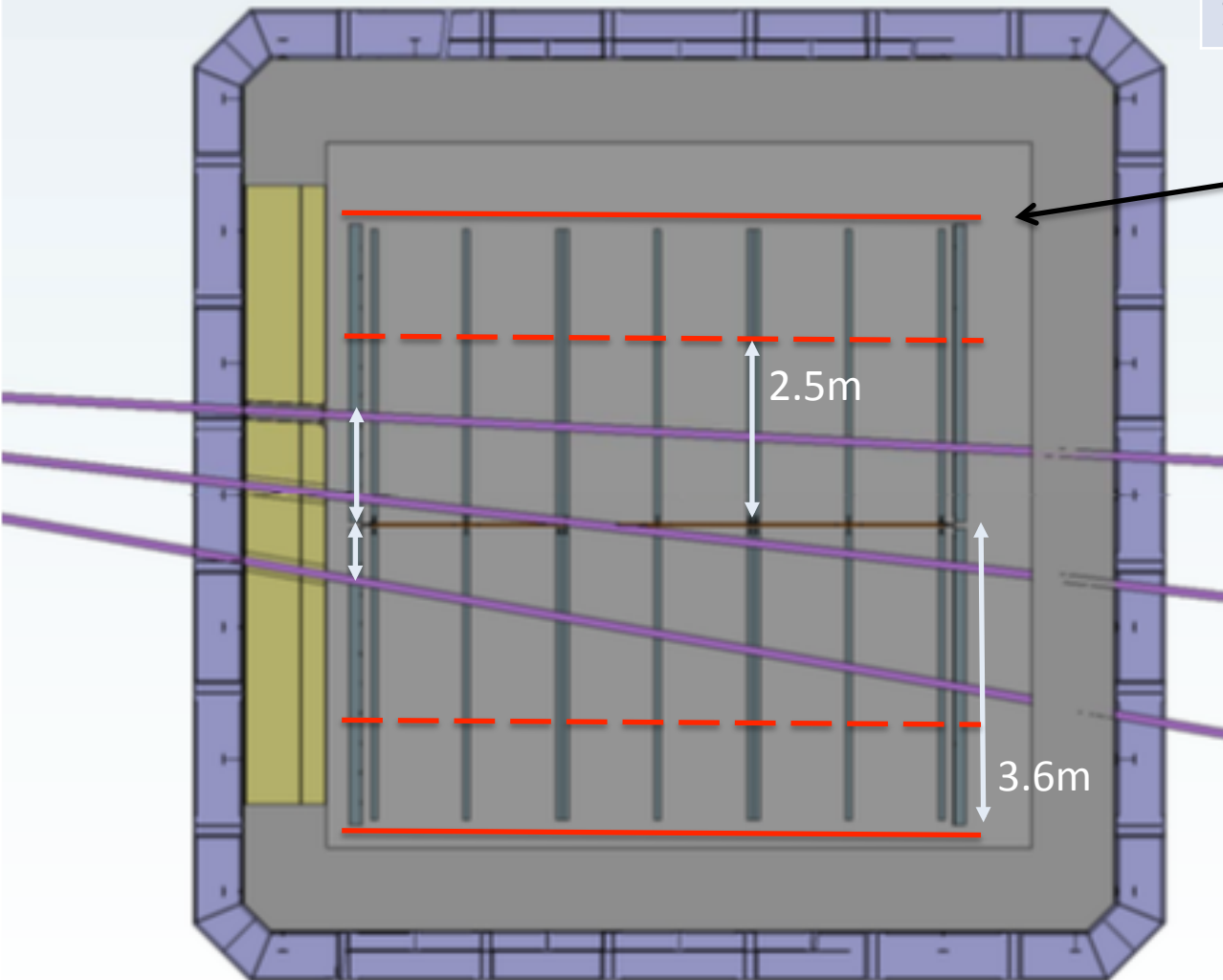

APA

3°

6.5°

10°

Numbers estimated from Tim's slides (approximate only)



Interference with cathode

Horizontal angle [°]	Off-set [cm]
3	145
6.5	15
10	-70

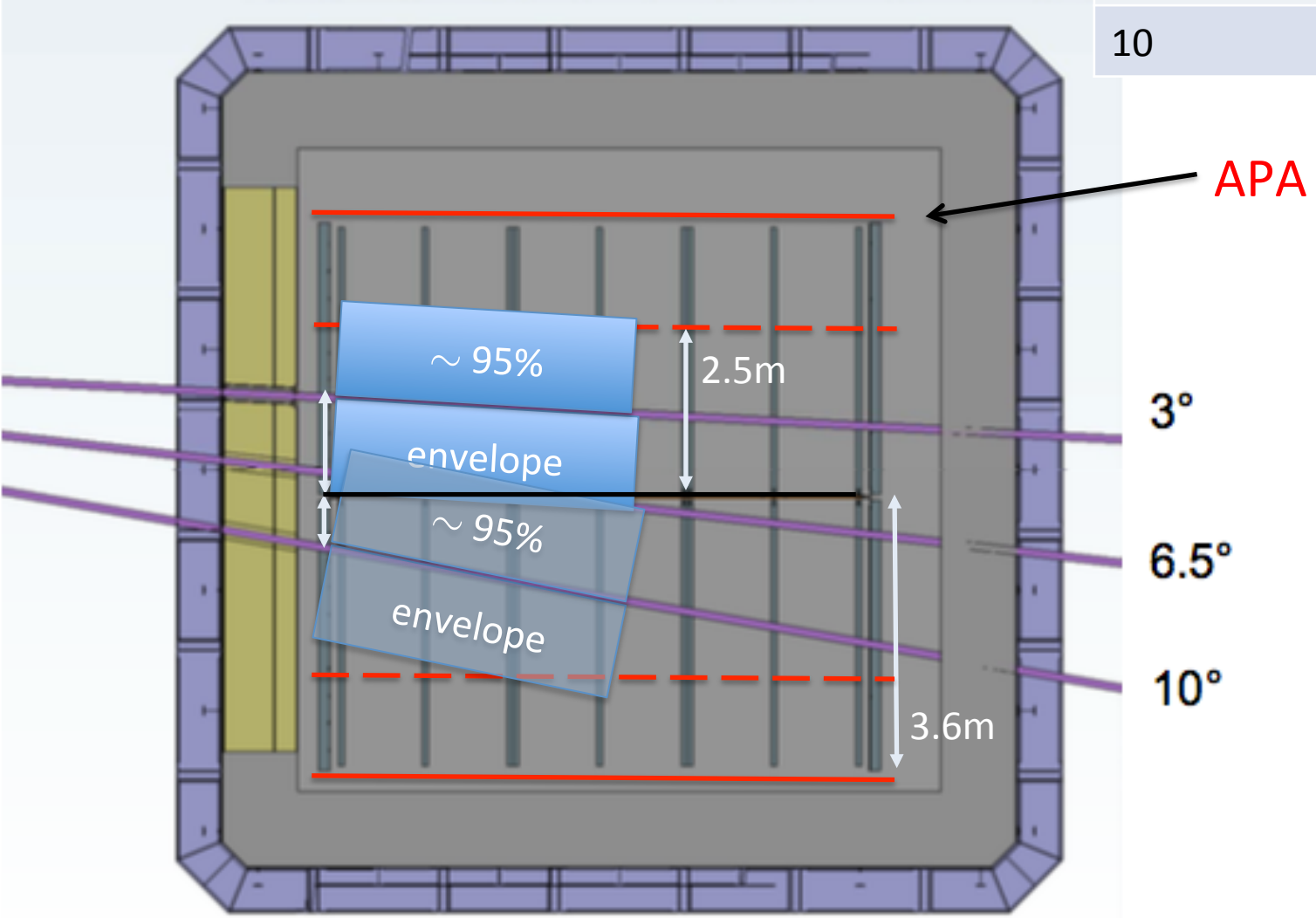

Recommendation for beam injection points:

→ minimize overlap between shower and passive detector components

Showers for lower energy primaries fully contained
In single drift volume (3.6m)

Horizontal angle [°]	Off-set [cm]	Drift length [cm]
$> \sim 3$	180	360
6.5	15	
10	-120	250

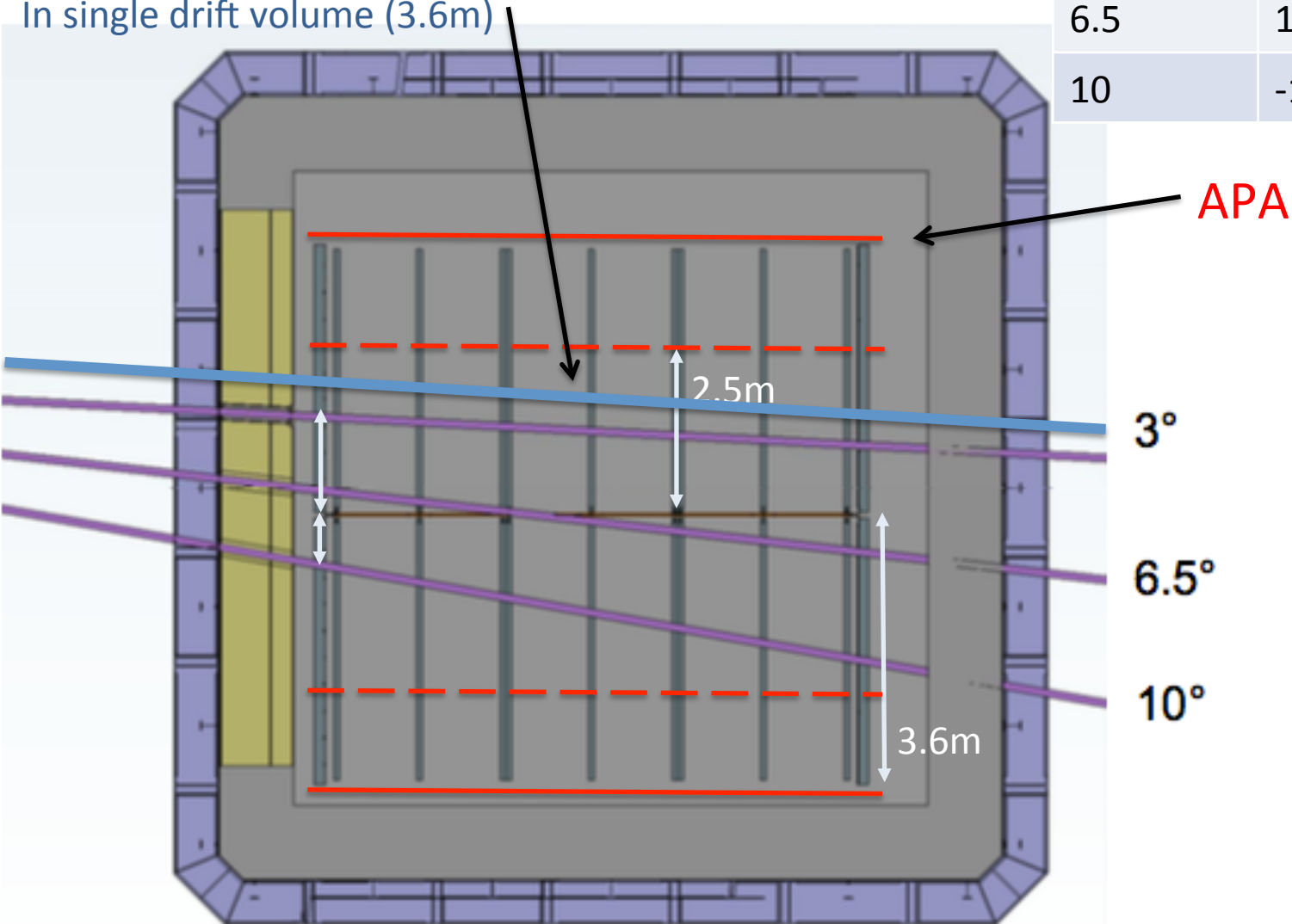

Vertical Beam access

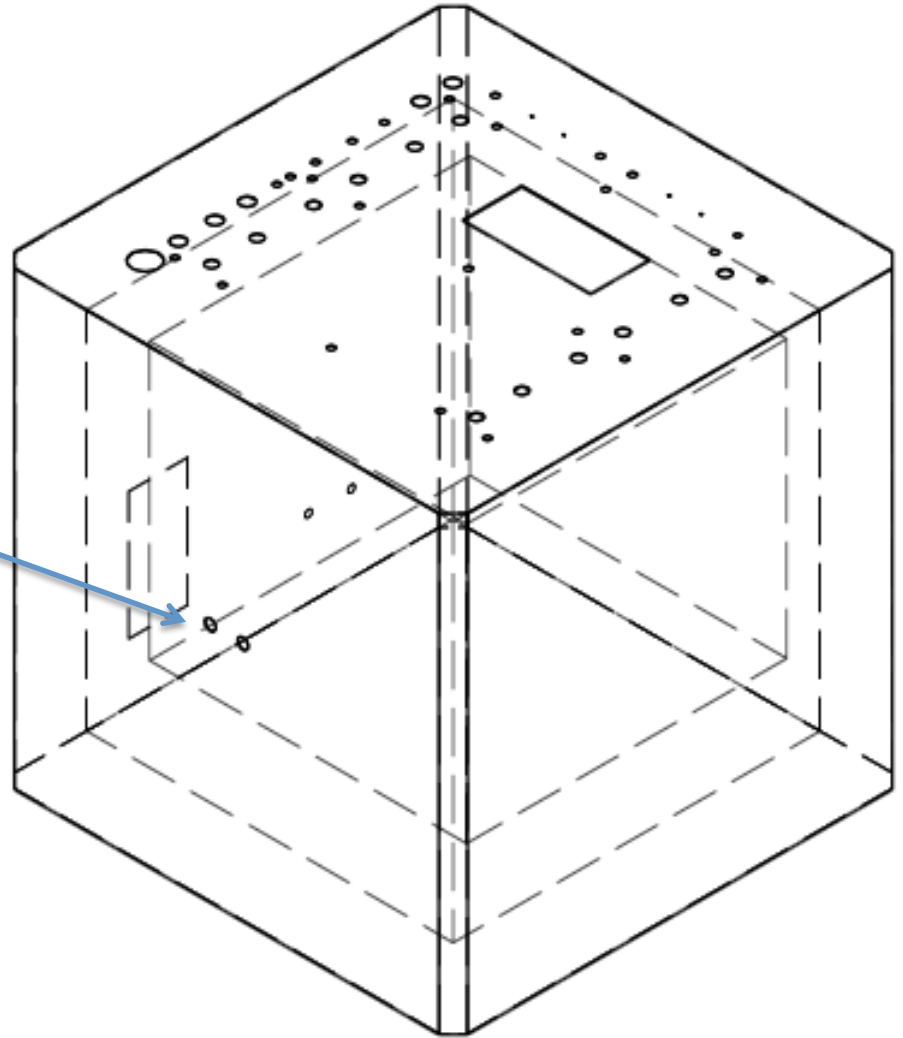

Presently included beam window positions

What is height relative to TPC ?

Presently defined feed-throughs

<https://edms.cern.ch/document/1543241>

<https://edms.cern.ch/document/1543254>

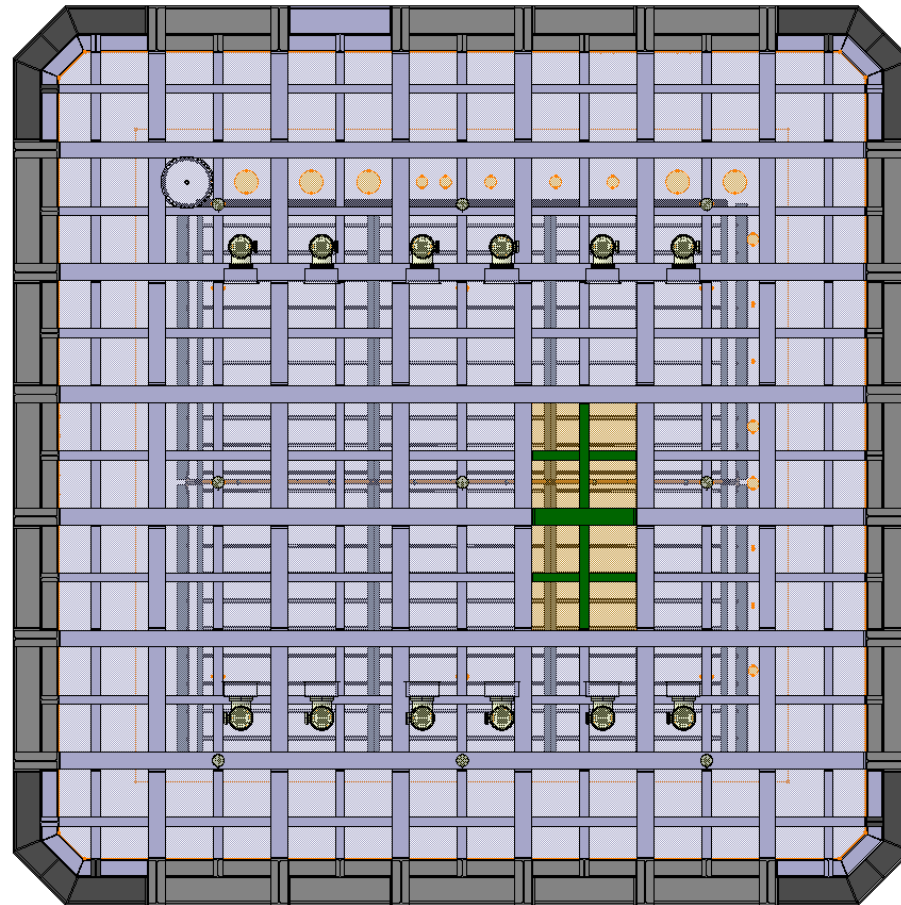

Pion Containment

