

# QCD and Monte-Carlo Event Generators

Stefan Höche

SLAC National Accelerator Laboratory

Hadron Collider Physics Summer School

Fermilab, 08/11/2016

- ▶ L. Dixon, F. Petriello (Editors)  
**Journeys Through the Precision Frontier**  
Proceedings of TASI 2014, World Scientific, 2015
- ▶ R. K. Ellis, W. J. Stirling, B. R. Webber  
**QCD and Collider Physics**  
Cambridge University Press, 2003
- ▶ R. D. Field  
**Applications of Perturbative QCD**  
Addison-Wesley, 1995
- ▶ A. Buckley et al.  
**General-Purpose Event Generators for LHC Physics**  
Phys. Rept. 504 (2011) 145
- ▶ T. Sjöstrand, S. Mrenna, P. Z. Skands  
**PYTHIA 6.4 Physics and Manual**  
JHEP 05 (2006) 026

- ▶ Recap and brief history of QCD
- ▶ Event structure at hadron colliders
- ▶ Perturbative QCD calculations
- ▶ Resummation and parton showers
- ▶ Matching fixed-order calculations and parton showers
- ▶ Non-factorizable terms and secondary interactions
- ▶ Hadronization & Particle decays

- ▶ 1960's → large zoo of hadrons discovered, systematization needed
- ▶ Gell-Mann, Ne'eman '62 → “eight-fold way”, prediction of  $\Omega$

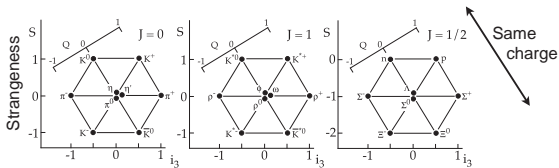

- ▶ Use SU(3) of flavor (isospin & strangeness) to classify hadrons
- ▶ Describes structure of low-lying multiplets very well

- ▶ Decuplets contains state with three identical quarks

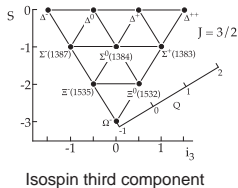

- ▶ Corresponds to all symmetric state  $\Delta^{++} = |u\uparrow u\uparrow u\uparrow\rangle$   
 → forbidden by Fermi statistics
- ▶ Rescue by postulating new degree of freedom → “color”

$$\Delta^{++} = N \sum \varepsilon_{ijk} |u_i\uparrow u_j\uparrow u_k\uparrow\rangle$$

- ▶ Color unobserved experimentally → SU(3) invariance of Lagrangian

- ▶ Lie algebra of  $SU(3)$  is  $[T^a, T^b] = if^{abc}T_c$
- ▶ Fundamental representation usually in terms of  $T^a = \lambda^a/2$  with Gell-Mann matrices

$$\lambda_1 = \begin{pmatrix} 0 & 1 & 0 \\ 1 & 0 & 0 \\ 0 & 0 & 0 \end{pmatrix} \quad \lambda_2 = \begin{pmatrix} 0 & -i & 0 \\ i & 0 & 0 \\ 0 & 0 & 0 \end{pmatrix} \quad \lambda_3 = \begin{pmatrix} 1 & 0 & 0 \\ 0 & -1 & 0 \\ 0 & 0 & 0 \end{pmatrix}$$

$$\lambda_4 = \begin{pmatrix} 0 & 0 & 1 \\ 0 & 0 & 0 \\ 1 & 0 & 0 \end{pmatrix} \quad \lambda_5 = \begin{pmatrix} 0 & 0 & -i \\ 0 & 0 & 0 \\ i & 0 & 0 \end{pmatrix} \quad \lambda_6 = \begin{pmatrix} 0 & 0 & 0 \\ 0 & 0 & 1 \\ 0 & 1 & 0 \end{pmatrix}$$

$$\lambda_7 = \begin{pmatrix} 0 & 0 & 0 \\ 0 & 0 & -i \\ 0 & i & 0 \end{pmatrix} \quad \lambda_8 = \begin{pmatrix} 1 & 0 & 0 \\ 0 & 1 & 0 \\ 0 & 0 & -2 \end{pmatrix}$$

- ▶  $\lambda_a^\dagger = \lambda_a$ ,  $\text{Tr}(\lambda^a) = 0$ ,  $\text{Tr}(\lambda^a \lambda^b) = 2\delta^{ab}$
- ▶ Fierz identity

$$\lambda_{ij}^a \lambda_{kl}^a = 2 \left( \delta_{il} \delta_{jk} - \frac{1}{3} \delta_{ij} \delta_{kl} \right)$$

- ▶ Adjoint representation:  $F_{bc}^a = -if_{abc}$

- Behaviour of quark field under gauge transformation

$$|u\rangle = \begin{pmatrix} u_1 \\ u_2 \\ u_3 \end{pmatrix} \rightarrow |u'\rangle = \exp \{ i g_s \alpha_a T^a \} \begin{pmatrix} u_1 \\ u_2 \\ u_3 \end{pmatrix}$$

- Covariant derivative  $D_\mu = \delta_\mu + i g_s T^a A_\mu^a$  with  $A_\mu \rightarrow$  gauge fields  
 $\rightarrow$  quark kinetic and quark-gluon interaction term:  $\mathcal{L} = \bar{q}(i\not{D} - m)q$

$$\begin{array}{c}
 q_j \\
 \swarrow \\
 \text{---} \text{---} \text{---} A_\mu^a \\
 \nwarrow \\
 q_i
 \end{array}
 = g_s \bar{q}_j \gamma^\mu T_{ji}^a q_i A_\mu^a$$

- Gluon kinetic and self-interaction term from QCD analog  $\mathcal{L} = \frac{1}{4} F^{\mu\nu} F_{\mu\nu}$

$$F_{\mu\nu}^a = \delta_\mu A_\nu^a - \delta_\nu A_\mu^a - g_s f_{abc} A_\mu^a A_\nu^b$$

$\rightarrow$  3- and 4-gluon interaction terms

- Non-abelian structure of QCD manifests itself in 3- and 4-gluon vertices

$$\begin{aligned}
 & \text{3-gluon vertex: } A_\nu^b(p_2) \text{ and } A_\rho^c(p_3) \text{ meet at } A_\mu^a(p_1) \\
 & = g_s f_{abc} \left[ g_{\mu\nu}(p_1 - p_2)_\rho + g_{\nu\rho}(p_2 - p_3)_\mu + g_{\rho\mu}(p_3 - p_1)_\nu \right] \\
 & \text{4-gluon vertex: } A_\nu^b \text{ and } A_\rho^c \text{ meet at } A_\mu^a \text{ and } A_\sigma^d \\
 & = -ig_s^2 \left[ f_{abe}f_{ecd}(g_{\mu\rho}g_{\nu\sigma} - g_{\mu\sigma}g_{\nu\rho}) + f_{ade}f_{ecb}(g_{\mu\rho}g_{\nu\sigma} - g_{\mu\nu}g_{\rho\sigma}) \right. \\
 & \quad \left. + f_{ace}f_{ebd}(g_{\mu\sigma}g_{\nu\rho} - g_{\mu\nu}g_{\rho\sigma}) \right]
 \end{aligned}$$



- ▶ Consider process  $q \rightarrow qg$  attached to some other diagrams

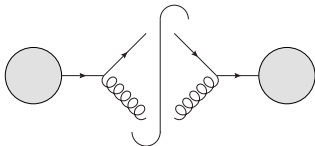

- ▶ Proportional to  $g_s^2 T_{ij}^a T_{jk}^a = 4\pi\alpha_s C_F \delta_{ik}$ , where

$$C_F = \frac{N_c^2 - 1}{2N_c} = \frac{4}{3}$$

- ▶ Identical to QED case except for color factor  $C_F$

- ▶ Consider process  $g \rightarrow q\bar{q}$  attached to some other diagrams

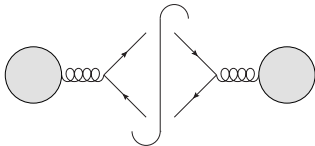

- ▶ Proportional to  $g_s^2 T_{ij}^a T_{ji}^b = 4\pi\alpha_s T_R \delta^{ab}$ , where

$$T_R = \frac{1}{2}$$

- ▶ Consider process  $g \rightarrow gg$  attached to some other diagrams

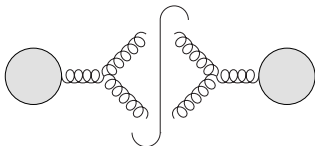

- ▶ Proportional to  $g_s^2 f^{abc} f^{bcd} = 4\pi\alpha_s C_A \delta^{ad}$ , where

$$C_A = N_c = 3$$

- ▶  $\rightarrow$  Gluons couple stronger to gluons than to quarks

- ▶ At low energy, QED potential looks like  $V(R) = -\frac{\alpha}{R}$

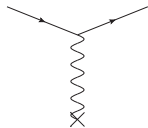

- ▶ When  $R \lesssim 1/m_e$ , vacuum polarization effects set in

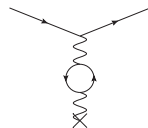

Potential changes to

$$V(R) = -\frac{\alpha}{R} \left[ 1 + \frac{2\alpha}{3\pi} \log \frac{1}{m_e R} + \mathcal{O}(\alpha^2) \right] = \frac{\bar{\alpha}(R)}{R}$$

where  $\bar{\alpha}(R) \rightarrow$  effective (running) coupling

- ▶ Understand effective coupling in analogy to solid state physics:
  - ▶ In insulators, charge screened by polarization of atoms
  - ▶ In QED, charge screened by newly created  $e^+e^-$  pairs

- ▶ In QCD, gauge bosons carry color  $\rightarrow$  screening & anti-screening

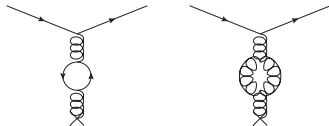

- ▶ Sum of contributions defines running of strong coupling at 1-loop

$$\mu^2 \frac{\partial \alpha_s(\mu^2)}{\partial \mu^2} = \beta(\alpha_s) \quad \text{where} \quad \beta(\alpha_s) = -\alpha_s \sum_{n=0} \frac{\alpha_s}{4\pi} \beta_n$$

- ▶ Coefficients known up to four loops

$$\beta_0 = \frac{11}{3} C_A - \frac{4}{3} T_R n_f$$

$$\beta_1 = \frac{17}{12} C_A^2 - \left( \frac{5}{6} C_A + \frac{1}{2} C_F \right) T_R n_f$$

...

- ▶ Unless  $n_f \geq 17$ , 1-loop beta function is negative  $\rightarrow$  confinement

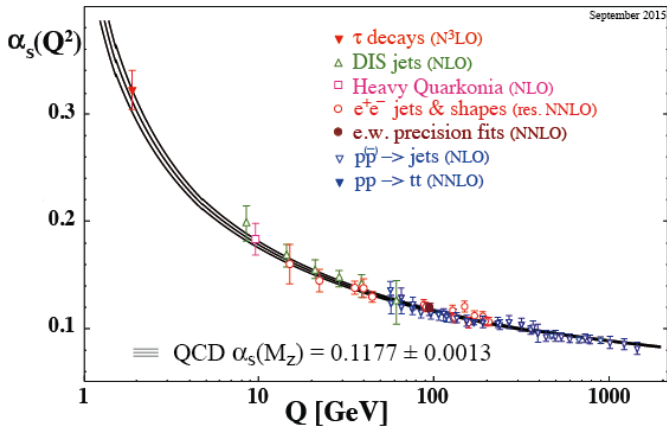
[Bethke] Proc. HP  $\alpha_s$  (2015)

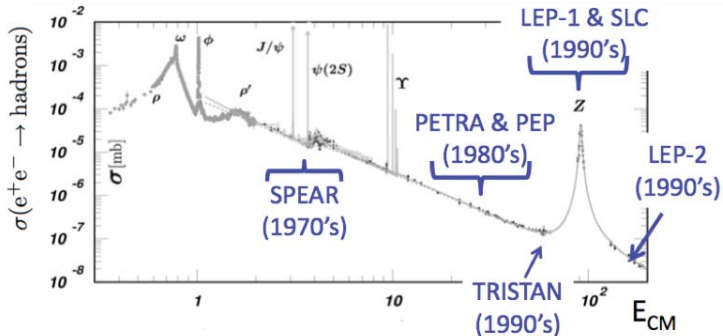

- ▶ SPEAR (SLAC): Discovery of quark jets
- ▶ PETRA (DESY) & PEP (SLAC): First high energy ( $>10$  GeV) jets  
Discovery of gluon jets (PETRA) & pioneering QCD studies
- ▶ LEP (CERN) & SLC (SLAC): Large energies  $\rightarrow$  more reliable QCD calculations, smaller hadronization uncertainties  
Large data samples  $\rightarrow$  precision tests of QCD

# Basic process for $e^+e^- \rightarrow \text{hadrons}$

- ▶ Prediction for  $e^+e^- \rightarrow q\bar{q}$  at leading perturbative order differs from  $e^+e^- \rightarrow \mu^+\mu^-$  only by quark charges

- ▶ Define ratio  $R = \frac{\sigma_{e^+e^- \rightarrow \text{hadrons}}}{\sigma_{e^+e^- \rightarrow \mu^+\mu^-}} \xrightarrow{\text{LO}} \sum_i e_{q,i}^2$

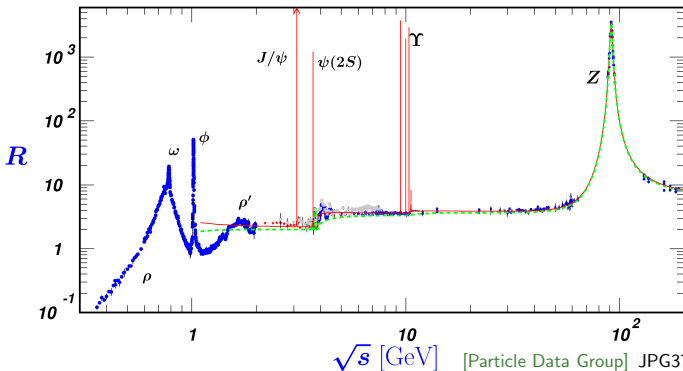
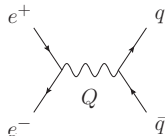

$\sqrt{s}$  [GeV] [Particle Data Group] JPG37(2010)075021

# Three-jet cross section & corrections to $e^+e^- \rightarrow \text{hadrons}$

- ▶ Kinematic variables  $x_i = \frac{2p_i \cdot Q}{Q^2}$

$$\rightarrow x_i < 1, \quad x_1 + x_2 + x_3 = 2$$

- ▶ Differential cross section

$$\frac{d^2\sigma}{dx_1 dx_2} = \sigma_0 \frac{\alpha_s}{\pi} C_F \frac{x_1^2 + x_2^2}{(1-x_1)(1-x_2)}$$

- ▶ Divergent as

- ▶  $x_1 \rightarrow 1$  ( $p_3 \parallel p_1$ )
- ▶  $x_2 \rightarrow 1$  ( $p_3 \parallel p_2$ )
- ▶  $(x_1, x_2) \rightarrow (1, 1)$  ( $x_3 \rightarrow 0$ )

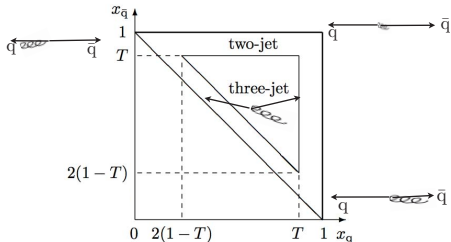
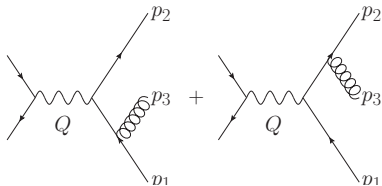

- ▶ Divergences canceled by virtual correction
- Total correction to  $e^+e^- \rightarrow \text{hadrons}$ :

$$\sigma^{\text{NLO}} = \sigma_0 \left( 1 + \frac{3}{4} C_F \frac{\alpha_s}{\pi} \right)$$

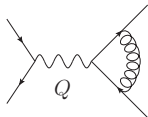



[TASSO] PLB86(1979)243 & Proc. Neutrino '79, Vol.1, p.113

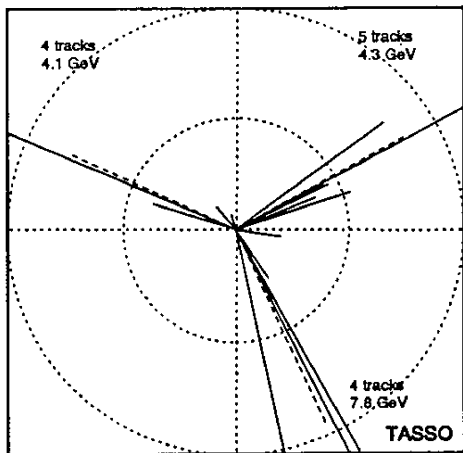
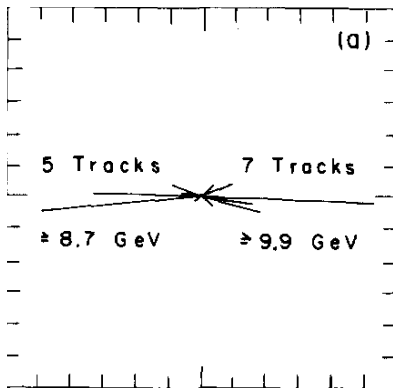

- ▶ Gluon discovery at the PETRA collider at DESY
- ▶ Typical three-jet event (right) vs. two-jet event (left)

[ALEPH]

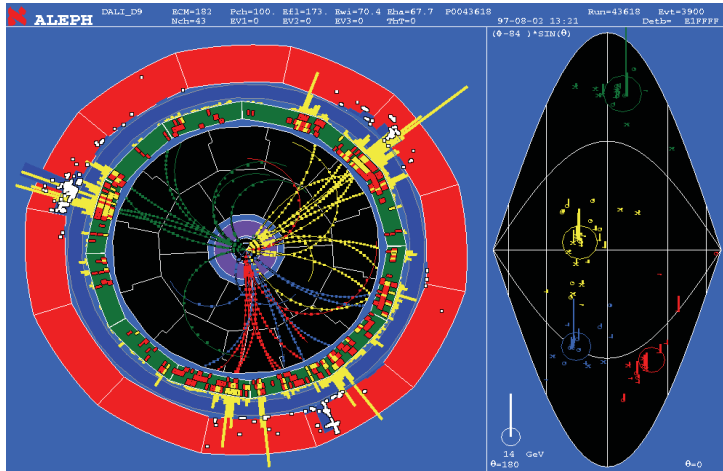

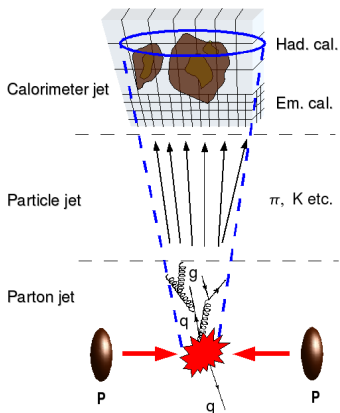

- ▶ Identify hadronic activity in experiment with partonic activity in pQCD theory

⇒ Requirements

- ▶ Applicable both to data and theory
  - ▶ partons
  - ▶ stable particles
  - ▶ measured objects (calorimeter objects, tracks, etc.)
- ▶ Gives close relationship between jets constructed from any of the above
- ▶ Independent of the details of the detector, e.g. calorimeter granularity

Further requirements from QCD

- ▶ Infrared safety  $\rightarrow$  no change when adding a soft particle

Counterexample:

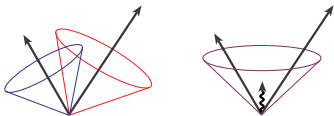

- ▶ Collinear safety  $\rightarrow$  no change when substituting particle with two collinear particles

Counterexample:

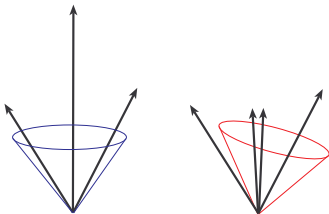

- ▶ Most widely used jet algorithms today of sequential recombination type
- ▶ Example: Durham algorithm
  1. Start with a list of preclusters
  2. For each pair of preclusters calculate

$$y_{ij} = \frac{2}{E_{cm}^2} \min \{E_i^2, E_j^2\} (1 - \cos \theta_{ij}) \approx \frac{k_T^2}{E_{cm}^2}$$

3. Identify  $y_{kl} = \min \{y_{ij}\}$
  4. If  $y_{kl} < y_{cut}$ , define all preclusters as jets and stop else merge preclusters  $k$  and  $l$  and continue at step 1
- ▶ Ambiguities:
    - ▶ Distance measure  $y_{ij}$  (e.g. Jade algorithm  $y_{ij} \rightarrow 2p_i p_j / E_{cm}^2$ )
    - ▶ Recombination scheme (e.g. four-momentum addition  $p_{kl} = p_k + p_l$ )
    - ▶ Resolution criterion  $y_{cut}$
  - ▶ For hadron collider algorithms, see [\[Salam\]](#) arXiv:0906.1833

[Catani,Olsson,Turnock,Webber] PLB269(1991)432

- ▶ Define jet-generating functional  $\phi$ , such that  $n$ -jet rate becomes

$$R_n^{(a)}(y_{\text{cut}} = Q_0^2/Q^2) = \frac{1}{n!} \left( \frac{\partial}{\partial u} \right)^n \phi_a(Q, Q_0; u)$$

- ▶ Evolution governed by coherent branching formalism ( $\nearrow$  later)

$$\begin{aligned} \frac{d\phi_a(q, Q_0; \phi^{(0)})}{d \log(q/Q_0)} &= \int_0^1 dz \sum_{b=q,g} \frac{\alpha_s}{2\pi} P_{ab}(z) \Theta[\min\{z, 1-z\}q - Q_0] \\ &\times \left[ \phi_b(zq, Q_0; \phi^{(0)}) \phi_c((1-z)q, Q_0; \phi^{(0)}) - \phi_a(q, Q_0; \phi^{(0)}) \right] \end{aligned}$$

- ▶ Jet rates can be computed analytically, e.g.

$$R_2^{(q)} = \exp \left\{ - \int_{s y_{\text{cut}}}^s \frac{dq^2}{q^2} \frac{C_F \alpha_s}{2\pi q^2} \left( \log \frac{s}{q^2} - \frac{3}{2} \right) \right\}$$

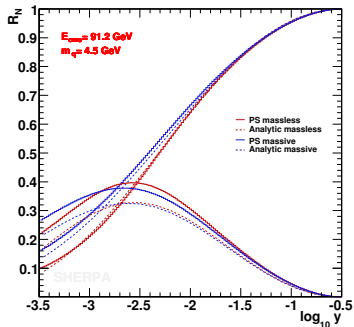
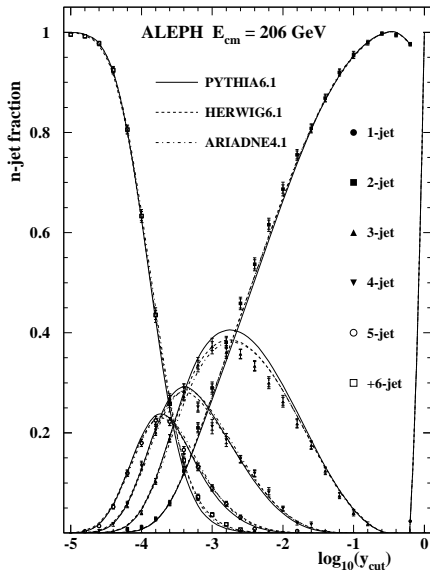

► Comparison between theory and Monte-Carlo simulation

- ▶ Shape variables characterize event as a whole
- ▶ Thrust (introduced 1978 at PETRA)

$$T = \max_{\vec{n}} \frac{\sum_i |\vec{p}_i \cdot \vec{n}|}{\sum_j |\vec{p}_j|}$$

- ▶  $T \rightarrow 1$  – back-to-back event
- ▶  $T \rightarrow 1/2$  – spherically symmetric event

Vector for which maximum is obtained  $\rightarrow$  thrust axis  $\vec{n}_T$

- ▶ Thrust major/minor

$$T_{\text{maj}} = \max_{\vec{n}_{\text{maj}} \perp \vec{n}_T} \frac{\sum_i |\vec{p}_i \cdot \vec{n}_{\text{maj}}|}{\sum_j |\vec{p}_j|}$$

$$T_{\text{min}} = \frac{\sum_i |\vec{p}_i \cdot (\vec{n}_T \times \vec{n}_{\text{maj}})|}{\sum_j |\vec{p}_j|}$$

- ▶ Jet broadening

$$B_i = \frac{\sum_{k \in H_i} |\vec{p}_k \times \vec{n}_T|}{2 \sum_j |\vec{p}_j|}$$

Computed for two hemispheres w.r.t.  $\vec{n}_T$ , then

- ▶  $B_W = \max(B_1, B_2)$  – Wide jet broadening
- ▶  $B_N = \min(B_1, B_2)$  – Narrow jet broadening



- ▶ Jet mass

$$M_i^2 = \frac{1}{E_{cm}^2} \left( \sum_{k \in H_i} p_k \right)^2$$

Computed for two hemispheres w.r.t.  $\vec{n}_T$ , then

- ▶  $\rho = \max(M_1^2, M_2^2)$  – Heavy jet mass
- ▶  $M_L = \min(M_1^2, M_2^2)$  – Light jet mass
- ▶ Quadratic momentum tensor

$$M^{\alpha\beta} = \frac{\sum_i p_i^\alpha p_i^\beta}{\sum_j |\vec{p}_j|^2}, \quad \alpha, \beta = 1, 2, 3$$

Eigenvalues  $\lambda_1 \geq \lambda_2 \geq \lambda_3$  used to define

- ▶  $S = \frac{3}{2}(\lambda_2 + \lambda_3)$  – Sphericity
- ▶  $A = \frac{3}{2}\lambda_3$  – Aplanarity
- ▶  $P = \lambda_2 - \lambda_3$  – Planarity
- ▶ C-Parameter

Linearized momentum tensor

$$\Theta^{\alpha\beta} = \frac{1}{\sum_j |\vec{p}_j|} \sum_i \frac{p_i^\alpha p_i^\beta}{|\vec{p}_i|},$$

Eigenvalues  $\lambda_i$  define  $C = 3(\lambda_1\lambda_2 + \lambda_2\lambda_3 + \lambda_3\lambda_1)$

- ▶ Discovery of quark and gluon jets – Sphericity & Oblateness
- ▶ Measurement of strong coupling constant –  $T$ ,  $C$ ,  $B$ ,  $\rho$ , Durham jet rates

[Dissertori et al.] arXiv:0906.3436

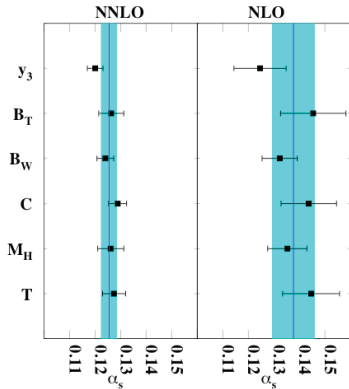
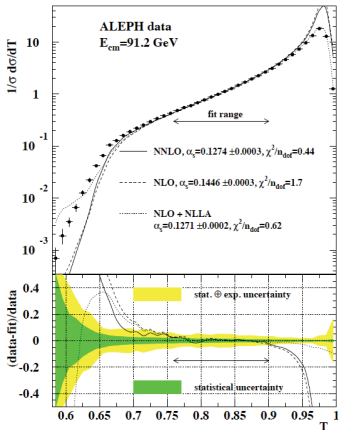

- ▶ Measurement of quark (and gluon) spin – Thrust axis
- ▶ Measurement of triple-gluon vertex – BZ angle

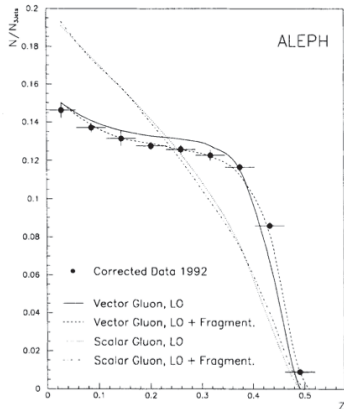
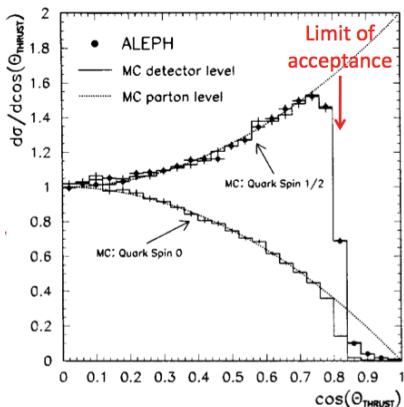

- ▶ Consider  $e^+e^- \rightarrow 3$  partons

$$\frac{1}{\sigma_{2 \rightarrow 2}} \frac{d\sigma_{2 \rightarrow 3}}{d \cos \theta dz} \sim C_F \frac{\alpha_s}{2\pi} \frac{2}{\sin^2 \theta} \frac{1 + (1-z)^2}{z}$$

$\theta$  - angle of gluon emission

$z$  - fractional energy of gluon

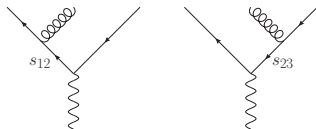

- ▶ Divergent in

- ▶ Collinear limit:  $\theta \rightarrow 0, \pi$
- ▶ Soft limit:  $z \rightarrow 0$

- ▶ Separate into two independent jets

$$\frac{2d \cos \theta}{\sin^2 \theta} = \frac{d \cos \theta}{1 - \cos \theta} + \frac{d \cos \theta}{1 + \cos \theta} = \frac{d \cos \theta}{1 - \cos \theta} + \frac{d \cos \bar{\theta}}{1 - \cos \bar{\theta}} \approx \frac{d\theta^2}{\theta^2} + \frac{d\bar{\theta}^2}{\bar{\theta}^2}$$

- ▶ Independent evolution with  $\theta$

$$d\sigma_3 \sim \sigma_2 \sum_{\text{jets}} C_F \frac{\alpha_s}{2\pi} \frac{d\theta^2}{\theta^2} dz \frac{1 + (1-z)^2}{z}$$

- ▶ Same equation for any variable with same limiting behavior

- ▶ Transverse momentum  $k_T^2 = z^2(1-z)^2\theta^2 E^2$
- ▶ Virtuality  $t = z(1-z)\theta^2 E^2$

- ▶ Call this the “evolution variable”

$$\frac{d\theta^2}{\theta^2} = \frac{dk_T^2}{k_T^2} = \frac{dt}{t} \quad \leftrightarrow \quad \text{collinear divergence}$$

- ▶ Absorb  $z$ -dependence into flavor-dependent splitting kernel  $P_{ab}(z)$

$$= C_F \frac{1+z^2}{1-z}$$

$$= C_F \frac{1+(1-z)^2}{z}$$

$$= T_R [z^2 + (1-z)^2]$$

$$= C_A \left[ \frac{z}{1-z} + \frac{1-z}{z} + z(1-z) \right]$$

- ▶ DGLAP evolution equation emerges, but so far only pQCD, no PDF

$$d\sigma_{n+1} \sim \sigma_n \sum_{\text{jets}} \frac{dt}{t} dz \frac{\alpha_s}{2\pi} P_{ab}(z)$$

- ▶ Hadronic cross section factorizes into perturbative & non-perturbative piece

$$\sigma = \sum_{a=q,g} \int dx f_a(x, Q^2) \hat{\sigma}_a(Q^2)$$

- ▶ Evolution from previous slide turns into evolution equation for  $f_a(x, Q^2)$
- ▶  $f_a(x, Q^2)$  cannot be predicted as function of  $x$  but dependence on  $Q^2$  can be computed order-by-order in pQCD
- ▶ DGLAP equation

$$\frac{d}{d \log(t/\mu^2)} f_q(x, t) \begin{array}{c} \nearrow q \\ \bullet \\ \searrow \end{array} = \int_x^1 \frac{dz}{z} \frac{\alpha_s}{2\pi} \begin{array}{c} \nearrow q \\ \bullet \\ \searrow \end{array} \begin{array}{c} P_{qq}(z) \\ \nearrow q \\ \bullet \\ \searrow \end{array} + \int_x^1 \frac{dz}{z} \frac{\alpha_s}{2\pi} \begin{array}{c} \nearrow q \\ \bullet \\ \searrow \end{array} \begin{array}{c} P_{gq}(z) \\ \nearrow g \\ \bullet \\ \searrow \end{array}$$

$$\frac{d}{d \log(t/\mu^2)} f_g(x, t) \begin{array}{c} \nearrow g \\ \bullet \\ \searrow \end{array} = \sum_{i=1}^{2n_f} \int_x^1 \frac{dz}{z} \frac{\alpha_s}{2\pi} \begin{array}{c} \nearrow g \\ \bullet \\ \searrow \end{array} \begin{array}{c} P_{qg}(z) \\ \nearrow q \\ \bullet \\ \searrow \end{array} + \int_x^1 \frac{dz}{z} \frac{\alpha_s}{2\pi} \begin{array}{c} \nearrow g \\ \bullet \\ \searrow \end{array} \begin{array}{c} P_{gg}(z) \\ \nearrow g \\ \bullet \\ \searrow \end{array}$$

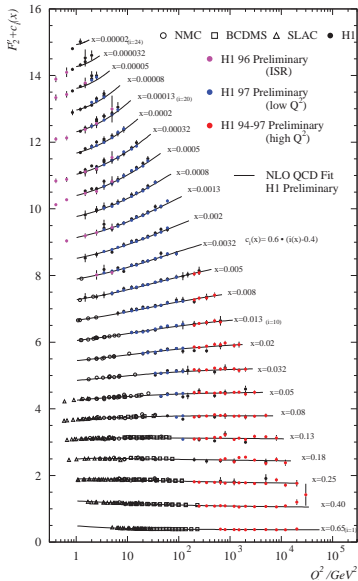
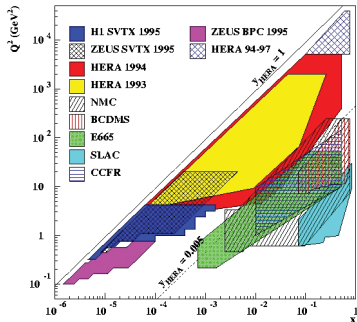

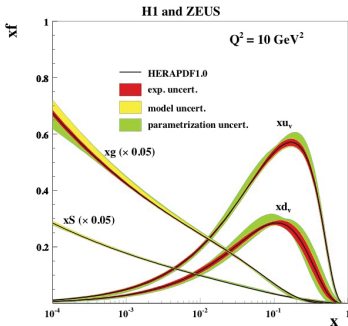
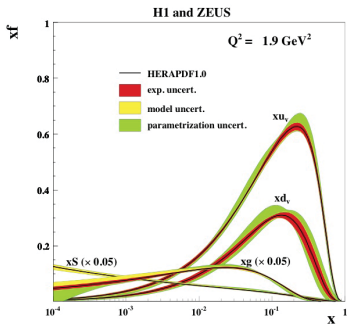



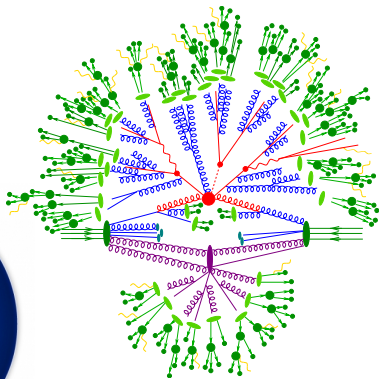
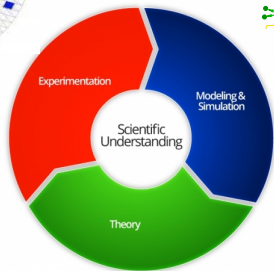
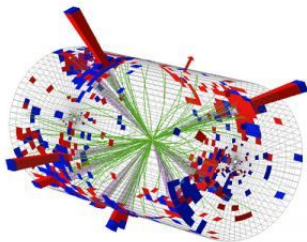

$$\mathcal{L} = -\frac{1}{4} F_{\mu\nu} F^{\mu\nu} + i\bar{\Psi}\not{D}\Psi + h.c.$$

[Andersson, Gustafson, Ingelman, Sjöstrand] Phys.Rept.97(1983)31

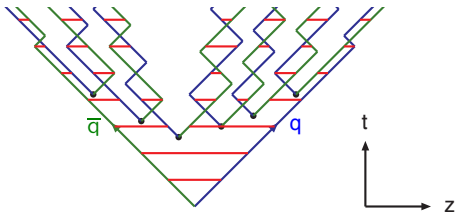
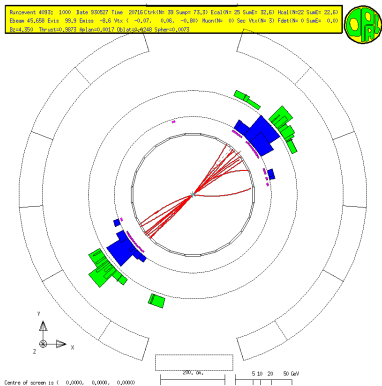

- ▶ Lund string model:  $\sim$  like rubber band that is pulled apart and breaks into pieces, or like a magnet broken into smaller pieces.
- ▶ Complete description of 2-jet events in  $e^+e^- \rightarrow$  hadrons

```

SUBROUTINE JETGEN(N)
  COMMON /JET/ K(IDO:2), P(100:5)
  COMMON /PAR/ PUD, PSI, SIGMA, CX2, EBEG, WFIN, IFLBEG
  COMMON /DAT1/ MESO(19:2), CMIX(6:2), PMAS(19)
  IFLSEN=(ID-IFLBE)/5
  N=2, EBEG
  I=0
  IPR=0
C 1 FLOURVU AND PT FOR FIRST QUARK
  IFL1=LABS(IFLBE)
  PT=SIGMA*SBOT*(-ALOS(RANF(D)))
  PHI=0.2832*PI*(RANF(D))
  PSI=PI*(COS(PHI))
  PY=PT*NSIN(PHI)
  I=0
  IPR=1
C 2 FLOURVU AND PT FOR NEXT ANTIQUARK
  IFL2=1+INT(RANF(D)/PUD)
  PT2=SIGMA*SBORT*(-ALOS(RANF(D)))
  PHI2=0.2832*PI*(RANF(D))
  PSI2=PI*(COS(PHI2))
  PY2=PT2*NSIN(PHI2)
C 3 MESON FORMED - SPIN ADDED AND FLOURVU MIXED
  K(1:1)=MESO(3)+(IFL1:1)+I*JL2, IFLSEN)
  ISPIN=INT(PSI+RANF(D))
  K(1:2)=+I*ISPIN*(K(1:1))
  IF(K(1:1), LE, 6) GOTO 150
  THX=PI*(RANF(D))
  MNA(K(1:1)+3)=ISPIN
  K(1:2)=8+I*ISPIN*INT(TMX+CMIX(K(1:1))+INT(TMIX+CMIX(K(1:2)))
C 4 MESONS FROM TABLE, PT FROM CONSTITUENTS
  I=0
  IPR=5, PMAS(K(1:2))
  P(1:1)=PSI*PI2
  P(1:2)=PSI*PI2
  PMT=(P(1:1)+P(1:2))+2**2*P(1:5)**2
C 5 RANDOM CHOICE OF E=(E1=PI2)MESON/(E+P2)AVAILABLE GIVES E AND P2
  I=ISPIN(D), LT, C12) X(1)=XXX(1./J.)
  P(1:3)=(X(N)-PMT)/(X(N)+X(N))/2.
  P(1:4)=(X(N)+PMT)/(X(N)+X(N))/2.
C 6 IF UNSTABLE, DECAY CHAIN INTO STABLE PARTICLES
  I=0
  IPR=IPR+1
  IF(K(IPR:2), GE, 6) CALL DECAY(IPR:1)
  IF(JP(D), LT, 1, AND, I, LE, 96) GOTO 120
C 7 FLOURVU AND PT OF QUARK FORMED IN PAIR WITH ANTIQUARK ABOVE
  IFL1=IFL
  PSI=PI*J
  PY=PY2
C 8 IF ENOUGH E+P2 LEFT, GO TO 2
  N=1-X(N)
  IF(M, GT, WFIN, AND, I, LE, 95) GOTO 100
  N=1
  RETURN
END

SUBROUTINE LIST(N)
  COMMON /JET/ K(IDO:2), P(100:5)
  COMMON /DAT2/ CHA1(9), CHA2(19), CHA3(2)
  WRITE(6,1410)
  DO 100 I=1,N
    IF(K(I:1), GT, 0) C1=CHA1(K(I:1))
    IF(K(I:1), LE, 0) IC1=K(I:1)
    C2=CHA2(K(I:2))
    C3=CHA3(K(I:2)+J(2))
    IF(K(I:1), GT, 0) WRITE(6,1200) I, C1, C2, C3, (P(I:J), J=1:5)
    IF(K(I:1), LE, 0) WRITE(6,1300) I, IC1, C2, C3, (P(I:J), J=1:5)
  100 RETURN
  110 FORMAT(///711, 'I', T17, '001', T24, 'PART', T32, 'STAB',
    & T64, 'PX', T56, 'PY', T68, 'PZ', T80, 'E', T92, 'M')
  120 FORMAT(///12, 'X', T6, 'C1', T14, 'C2', T22, 'C3', T30, 'E',
    & T38, 'P1', T46, 'P2', T54, 'P3', T62, 'P4', T70, 'P5')
  130 FORMAT(///12, 'X', T6, 'IC1', T14, 'C2', T22, 'C3', T30, 'E',
    & T38, 'P1', T46, 'P2', T54, 'P3', T62, 'P4', T70, 'P5')
  END

```

≈ 200 punched cards  
Fortran code



Event: 531676916  
2015-08-22 04:20:10 CEST

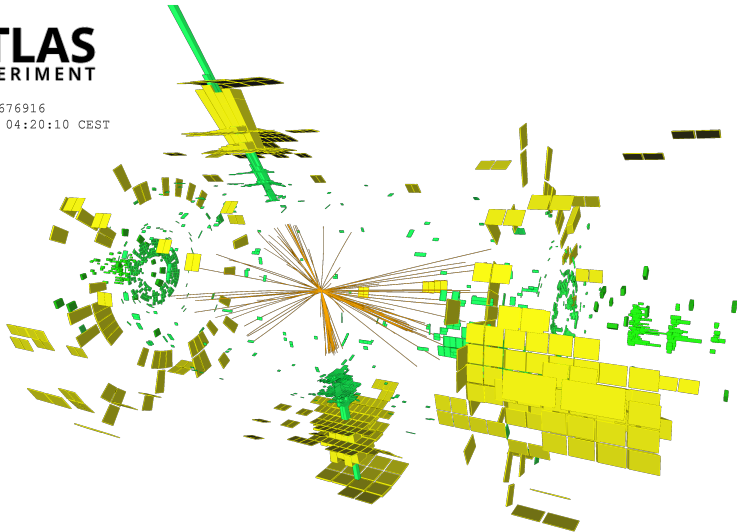

## Need to cover large dynamic range

- ▶ Short distance interactions
  - ▶ Signal process
  - ▶ Radiative corrections
- ▶ Long-distance interactions
  - ▶ Hadronization
  - ▶ Particle decays

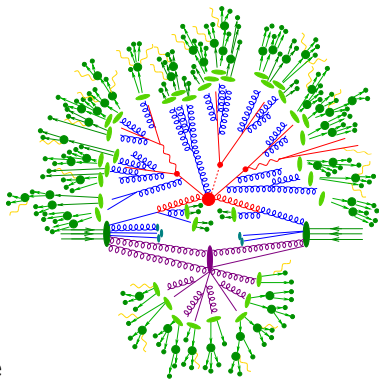

## Divide and Conquer

- ▶ Quantity of interest: Total interaction rate
- ▶ Convolution of short & long distance physics

$$\sigma_{p_1 p_2 \rightarrow X} = \sum_{i,j \in \{q,g\}} \int dx_1 dx_2 \underbrace{f_{p_1,i}(x_1, \mu_F^2) f_{p_2,j}(x_2, \mu_F^2)}_{\text{long distance}} \underbrace{\hat{\sigma}_{ij \rightarrow X}(x_1 x_2, \mu_F^2)}_{\text{short distance}}$$

## Herwig

- ▶ Originated in coherent shower studies → angular ordered PS
- ▶ Front-runner in development of MC@NLO and POWHEG
- ▶ Simple in-house ME generator & spin-correlated decay chains
- ▶ Original framework for cluster fragmentation

## Pythia

- ▶ Originated in hadronization studies → Lund string
- ▶ Leading in development of multiple interaction models
- ▶ Pragmatic attitude to ME generation → external tools
- ▶ Extensive PS development and earliest ME $\oplus$ PS matching

## Sherpa

- ▶ Started with PS generator APACIC++ & ME generator AMEGIC++
- ▶ Current MPI model and hadronization pragmatic add-ons
- ▶ Leading in development of automated ME $\oplus$ PS merging
- ▶ Automated framework for NLO calculations and MC@NLO

## Rivet [Buckley et al.] arXiv:0103.0694

- ▶ LHC-successor to HZTool  
Collection of exp. data & matching analysis routines
- ▶ Spirit: “Right MC describes everything at the same time”

## Professor [Buckley et al.] arXiv:0907.2973

- ▶ Tuning in multi-dimensional parameter space of MC
- ▶ Generate event samples at random parameter points  
Analyze them with Rivet  
Parametrize observables  
Minimize  $\chi^2$  and cross-check

## Tune comparisons

Deviation metrics per gen/tune and observable group:

Gen	Tune	UE	Dijets	Multijets	jet shapes	W and Z	Fragmentation	B frag
AlpGen	HERWIG6	—	1.83	5.36	2.48	0.91	—	—
	PYTHIA6-AMBT1	—	1.55	2.80	0.61	0.53	—	—
	PYTHIA6-D6T	—	1.38	2.67	2.31	1.67	—	—
	PYTHIA6-P2010	—	1.09	2.65	2.03	1.48	—	—
	PYTHIA6-P2011	—	1.12	2.60	0.48	0.24	—	—
	PYTHIA6-Z2	—	1.48	2.63	0.55	0.48	—	—
	PYTHIA6-profQ2	—	1.16	2.65	1.43	1.29	—	—
HERWIG	AUET2-CTEQ6L1	0.43	0.55	0.77	0.35	0.58	22.80	2.38
	AUET2-LOxx	0.25	0.71	0.60	0.39	0.88	22.13	2.29
Herwig++	2.5.1-UE-EE-3-CTEQ6L1	0.27	0.87	0.78	0.51	0.98	10.58	1.32
	2.5.1-UE-EE-3-MRSTLOxx	0.23	1.05	0.78	0.50	0.65	10.58	1.32
PYTHIA6	AMBT1	0.39	1.20	0.54	0.77	0.27	0.93	1.65
	AUET2B-CTEQ6L1	0.16	0.92	0.44	0.59	0.74	0.67	1.29
	AUET2B-LOxx	0.13	1.33	0.55	0.58	1.15	0.67	1.30
	D6T	0.58	0.79	0.50	0.56	1.25	0.36	2.63
	DW	0.81	0.78	0.61	0.56	1.33	0.36	2.63
	P2010	0.30	0.93	0.82	1.07	0.30	0.44	1.75
	P2011	0.12	0.89	0.67	1.02	0.53	0.43	2.13
ProfQ2	0.51	0.67	0.81	0.51	0.64	0.30	1.65	
Z2	0.18	0.94	0.73	0.80	0.30	0.95	2.78	
Pythia8	4C	0.30	0.97	0.93	0.50	0.90	0.38	1.12
Sherpa	1.3.1	0.68	0.47	0.34	0.71	0.36	0.75	2.48

[LH'11 SM WG] arXiv:1203.6803 [hep-ph]

- ▶ Hard interaction
- ▶ QCD evolution
- ▶ Secondary hard interactions
- ▶ Hadronization
- ▶ Hadron decays
- ▶ Higher-order QED corrections

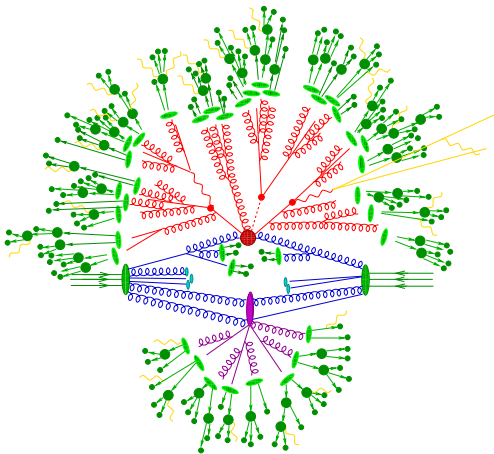



- ▶ **Textbook:** Use completeness relations to square amplitudes  
sum/average over external states (helicity and color)  
Computational effort grows quadratically with number of diagrams
- ▶ **Real life:** Amplitudes are complex numbers  
first compute them, then add and square  
Effort grows linearly with number of diagrams
- ▶ Applies to dynamical degrees of freedom only
  - ▶ Consider helicity: Polarizations depend on momenta  
need to recompute for each phase-space point
  - ▶ Consider color: Mostly summed over at low multiplicity  
independent of other d.o.f. → no need to recompute

- ▶ Weyl-van-der-Waerden spinors for helicity states  $+/-$

$$\chi_+(p) = \begin{pmatrix} \sqrt{p^+} \\ \sqrt{p^-} e^{i\phi_p} \end{pmatrix} \quad \chi_-(p) = \begin{pmatrix} \sqrt{p^-} e^{i\phi_p} \\ -\sqrt{p^+} \end{pmatrix} \quad \begin{aligned} p^\pm &= p^0 \pm p^3 \\ p_\perp &= p^1 + ip^2 \end{aligned}$$

Basic building blocks for all amplitudes

$+$ ,  $-$ ,  $\perp$  directions define “spinor gauge”

- ▶ Massive Dirac spinors in terms of WvdW spinors

$$u_+(p, m) = \frac{1}{\sqrt{2\bar{p}}} \begin{pmatrix} \sqrt{p_0 - \bar{p}} \chi_+(\hat{p}) \\ \sqrt{p_0 + \bar{p}} \chi_+(\hat{p}) \end{pmatrix} \quad \bar{p} = \text{sgn}(p_0) |\vec{p}|$$

$$u_-(p, m) = \frac{1}{\sqrt{2\bar{p}}} \begin{pmatrix} \sqrt{p_0 + \bar{p}} \chi_-(\hat{p}) \\ \sqrt{p_0 - \bar{p}} \chi_-(\hat{p}) \end{pmatrix} \quad \hat{p} = (\bar{p}, \vec{p})$$

- ▶  $\gamma^5$  conveniently defined in Weyl representation

$$\gamma^5 = i\gamma^0\gamma^1\gamma^2\gamma^3 = \begin{pmatrix} -\sigma^0 & 0 \\ 0 & \sigma^0 \end{pmatrix}$$

Projection operator  $P_{R,L} = P_\pm = (1 \pm \gamma^5)/2$  identifies

lower/upper component of Dirac spinors as right-/left-handed

- ▶ Massless polarizations constructed from  $u_{\pm}(p)$  and  $u_{\pm}(k)$  with external light-like gauge vector  $k$

$$\varepsilon_{\pm}^{\mu}(p, k) = \pm \frac{\bar{u}_{\mp}(k)\gamma^{\mu}u_{\mp}(p)}{\sqrt{2}\bar{u}_{\mp}(k)u_{\pm}(p)} .$$

Defines light-like axial gauge

- ▶ For massive particles decompose momentum  $p$  using  $k$

$$b = p - \kappa k \quad \kappa = \frac{p^2}{2pk} \quad \Rightarrow \quad b^2 = 0$$

Transverse polarizations as in massless case ( $p \rightarrow b$ ) plus longitudinal

$$\varepsilon_0^{\mu}(p, k) = \frac{1}{m} (\bar{u}_-(b)\gamma^{\mu}u_-(b) - \kappa \bar{u}_-(k)\gamma^{\mu}u_-(k))$$

- ▶ Vertices & propagators already known
- ▶ Building blocks for Standard model complete!

[Maltoni,Stelzer,Willenbrock] hep-ph/0209271

[Duhr,SH,Maltoni] hep-ph/0607057

- ▶ QCD amplitudes can be stripped of color factors
- ▶ Fundamental representation for  $n$ -gluons

$$\mathcal{A}_n(p_1, \dots, p_n) = \sum_{\vec{\sigma} \in P(2, \dots, n)} \text{Tr}(\lambda^{a_1} \lambda^{a_{\sigma_2}} \dots \lambda^{a_{\sigma_n}}) A(p_1, p_{\sigma_2}, \dots, p_{\sigma_n})$$

- ▶ Adjoint representation for  $n$ -gluons

$$\mathcal{A}_n(p_1, \dots, p_n) = \sum_{\vec{\sigma} \in P(2, \dots, n-1)} [F^{a_{\sigma_2}} \dots F^{a_{\sigma_{n-1}}}]_{a_n}^{a_1} A(p_1, p_{\sigma_2}, \dots, p_{\sigma_{n-1}}, p_n)$$

- ▶ Color-flow representation for  $n$ -gluons

$$\mathcal{A}_n(p_1, \dots, p_n) = \sum_{\vec{\sigma} \in P(2, \dots, n)} \delta_{j_1 \sigma_2}^{i_1} \delta_{j_2 \sigma_3}^{i_2} \dots \delta_{j_1 \sigma_n}^{i_n} A(p_1, p_{\sigma_2}, \dots, p_{\sigma_n})$$

- ▶ We can sample colors just like we sample momenta
- ▶ Assign one in  $(r, g, b) / (\bar{r}, \bar{g}, \bar{b})$  to each external (anti-)quark & gluon
- ▶ Average number of partial amplitudes is then smallest in color-flow basis

$n$	Average # of partials		
	Gell-Mann	Color-flow	Adjoint
4	4.83	1.28	1.15
5	15.2	1.83	1.52
6	56.5	3.21	2.55
7	251	6.80	5.53
8	1280	17.0	15.8
9	7440	48.7	56.4
10	47800	158	243

$n$	Time [s/ $10^4$ pt]	
	CO	CD
4	1.20	1.04
5	3.78	2.69
6	14.2	7.19
7	58.5	23.7
8	276	82.1
9	1450	270
10	7960	864

- ▶ Computational effort reduced further by not stripping amplitudes of color factors
- ▶ Evaluate dynamically at each vertex  
→ straightforward computer algorithm
- ▶ Color dressing (CD) vs. color ordering (CO)

Example: Diagrams for  $g(1)g(2) \rightarrow g(3)g(4)$

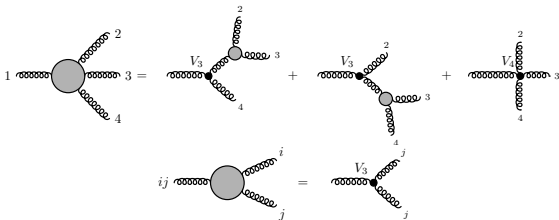

[Berends,Giele] NPB306(1988)759

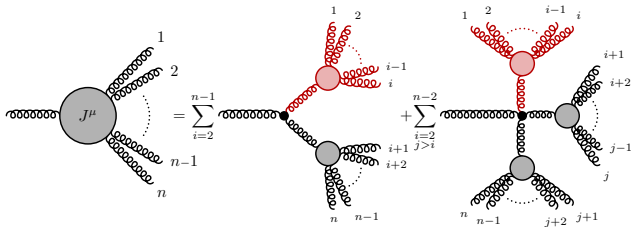

Example: Currents for  $g(1)g(2) \rightarrow g(3)g(4)$

- |        |                                 |                        |                        |                        |
|--------|---------------------------------|------------------------|------------------------|------------------------|
| Step 1 | $J_1 = \varepsilon(1)$          | $J_2 = \varepsilon(2)$ | $J_3 = \varepsilon(3)$ | $J_4 = \varepsilon(4)$ |
| Step 2 | $J_{12}$                        | $J_{13}$               | $J_{23}$               |                        |
| Step 3 | $J_{123}$                       |                        |                        |                        |
| Step 4 | $A(1, 2, 3, 4) = J_4^* J_{123}$ |                        |                        |                        |

[James] CERN-68-15

[Byckling,Kajantie] NPB9(1969)568

- ▶ Need to evaluate in a process-independent way

$$d\Phi_n(p_a, p_b; p_1, \dots, p_n) = \left[ \prod_{i=1}^n \frac{d^3 p_i}{(2\pi)^3 2E_i} \right] \delta^4 \left( p_a + p_b - \sum_{i=1}^n p_i \right)$$

- ▶ Use factorization properties of phase-space integral

$$d\Phi_n(p_a, p_b; p_1, \dots, p_n) = d\Phi_{n-m+1}(p_a, p_b; p_{1m}, p_{m+1}, \dots, p_n) \\ \times \frac{ds_{1m}}{2\pi} d\Phi_m(p_{1m}; p_1, \dots, p_m)$$

- ▶ Apply repeatedly until only 2-particle phase spaces remain

$$d\Phi_2 = \frac{\lambda(s_{ij}, m_i^2, m_j^2)}{16\pi^2 2s_{ij}} d\cos\theta_i d\phi_i$$

$$\lambda^2(a, b, c) = (a - b - c)^2 - 4bc - \text{Källén function}$$

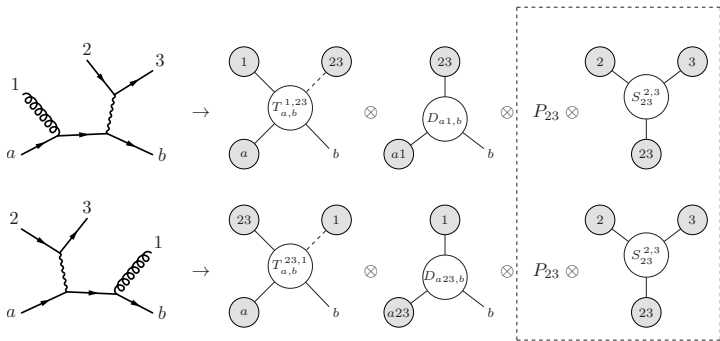

- ▶ Construct one integrator per diagram and combine into multi-channel
- ▶ Intuitive notion of pole structure, multi-channel determines balance
- ▶ Factorial growth with number of diagrams can be tamed by recursion



NLO calculation

$$\left\{ \begin{array}{l} \text{Born term:} \quad B = \int \text{diagram} \\ \text{Virtual terms:} \quad V = \sum 2 \text{Re} \left\{ \int \text{diagram} \right\} \\ \text{Real terms:} \quad R = \sum \int \text{diagram} \end{array} \right.$$

The Born term diagram shows two orange circles connected by a curved line, with four external lines. The virtual terms diagram shows a similar structure but with a loop on the left circle. The real terms diagram shows two orange circles with a loop on each, connected by a curved line, with four external lines.

- ▶ UV divergences in  $V$  removed by renormalization procedure
- ▶  $V$  and  $R$  both still infrared divergent
- ▶ IR divergences cancel between  $V$  and  $R$  (KLN theorem)
- ▶ Exploit this fact to construct finite integrand for MC

[Frixione, Webber] hep-ph/0204244

- ▶ Assume system of charged particles which radiates “photons” of fractional energy  $x$ .
- ▶ Predicting infrared-safe observables  $O$  amounts to computing expectation values

$$\langle O \rangle = \lim_{\varepsilon \rightarrow 0} \int_0^1 dx x^{-2\varepsilon} O(x) \left[ \left( \frac{d\sigma}{dx} \right)_B + \left( \frac{d\sigma}{dx} \right)_V + \left( \frac{d\sigma}{dx} \right)_R \right]$$

- ▶ Born, virtual and real-emission contributions given by

$$\left( \frac{d\sigma}{dx} \right)_{B,V,R} = B \delta(x), \quad \left( V_f + \frac{BC}{2\varepsilon} \right) \delta(x), \quad \frac{R(x)}{x}$$

Real-emission behaves as  $\lim_{x \rightarrow 0} R(x) = BC$

Virtual correction  $\begin{cases} V_f & - \text{finite piece} \\ BC/2\varepsilon & - \text{singular piece} \end{cases}$

Implicit: All higher-order terms proportional to coupling  $\alpha$

- ▶ Perform NLO calculation in subtraction method

$$\langle O \rangle_R = BC O(0) \int_0^1 dx \frac{x^{-2\varepsilon}}{x} + \int_0^1 dx \frac{R(x) O(x) - BC O(0)}{x^{1+2\varepsilon}}$$

- ▶ Second integral non-singular  $\rightarrow$  set  $\varepsilon = 0$

$$\langle O \rangle_R = -\frac{BC}{2\varepsilon} O(0) + \int_0^1 dx \frac{R(x) O(x) - BC O(0)}{x}$$

- ▶ Combine everything with Born and virtual correction

$$\langle O \rangle = (B + V_f) O(0) + \int_0^1 \frac{dx}{x} [R(x) O(x) - BC O(0)]$$

Both terms separately finite

- ▶ Rewrite for further reference

$$\langle O \rangle = (B + V + I) O(0) + \int_0^1 \frac{dx}{x} [R(x) O(x) - S O(0)]$$

$I = -BC/2\varepsilon \rightarrow$  Integrated subtraction term

$S = BC \rightarrow$  Real subtraction term

- ▶ QCD subtraction a little more cumbersome due to spin and colour correlations in  $\mathbb{R}$
- ▶ Basic features surviving from toy model are phase-space mapping and subtraction terms as products of Born times splitting operator
- ▶ Commonly used techniques
  - ▶ Dipole method
    - [Catani,Seymour] NPB485(1997)291
    - [Catani,Dittmaier,Seymour,Trocsanyi] NPB627(2002)189
  - ▶ FKS method
    - [Frixione,Kunszt,Signer] NPB467(1996)399

► Commonly used ME generators

	Built-in models	$2 \rightarrow$	$ M_n ^2$	$d\Phi_n$	NLO
ALPGEN	SM	8	recursive	Multi	-
AMEGIC	SM,MSSM,ADD	6	diagrams	Multi	sub
Comix	SM	8	recursive	Multi	sub
CompHEP	SM,MSSM	4	textbook	Single	-
HELAC	SM	8	recursive	Multi	sub+loop
MadEvent	SM,MSSM,UED	6	diagrams	Multi	sub+loop
Whizard	SM,MSSM,LH	8	recursive	Multi	sub

[Christensen,Duhr] arXiv:0806.4194

- ▶ Most ME generators suited for any physics model, but implementing Feynman rules tedious and error-prone
- ▶ Automated by FeynRules package
- ▶ Extracts vertices from Lagrangian based on minimal information about particle content
- ▶ Writes generator-specific output permitting easy cross-checks

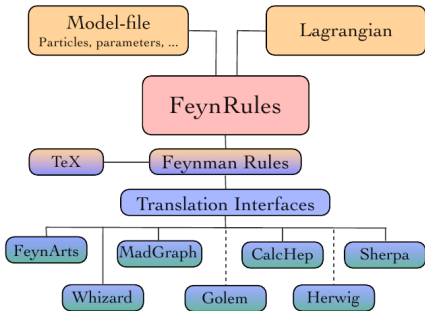

- ▶ Hard interaction
- ▶ QCD evolution
- ▶ Secondary hard interactions
- ▶ Hadronization
- ▶ Hadron decays
- ▶ Higher-order QED corrections

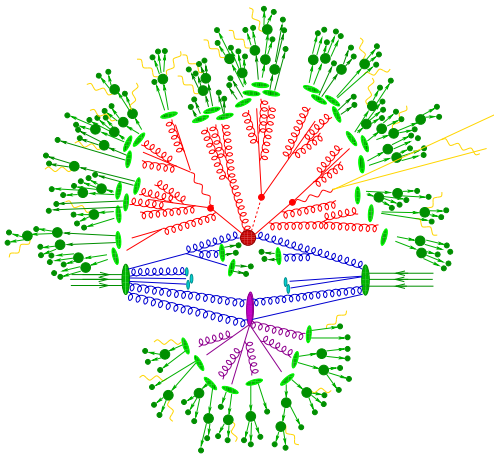

- ▶ Consider  $e^+e^- \rightarrow 3$  partons

$$\frac{1}{\sigma_{2 \rightarrow 2}} \frac{d\sigma_{2 \rightarrow 3}}{d \cos \theta dz} \sim C_F \frac{\alpha_s}{2\pi} \frac{2}{\sin^2 \theta} \frac{1 + (1-z)^2}{z}$$

$\theta$  - angle of gluon emission

$z$  - fractional energy of gluon

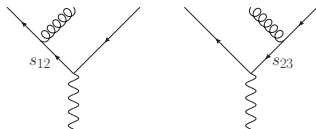

- ▶ Divergent in

- ▶ Collinear limit:  $\theta \rightarrow 0, \pi$

- ▶ Soft limit:  $z \rightarrow 0$

- ▶ Separate into two independent jets

$$\frac{2d \cos \theta}{\sin^2 \theta} = \frac{d \cos \theta}{1 - \cos \theta} + \frac{d \cos \theta}{1 + \cos \theta} = \frac{d \cos \theta}{1 - \cos \theta} + \frac{d \cos \bar{\theta}}{1 - \cos \bar{\theta}} \approx \frac{d\theta^2}{\theta^2} + \frac{d\bar{\theta}^2}{\bar{\theta}^2}$$

- ▶ Independent jet evolution

$$d\sigma_3 \sim \sigma_2 \sum_{\text{jets}} C_F \frac{\alpha_s}{2\pi} \frac{d\theta^2}{\theta^2} dz \frac{1 + (1-z)^2}{z} \rightarrow \sigma_2 \sum_{\text{jets}} \frac{dt}{t} dz \frac{\alpha_s}{2\pi} P_{ab}(z)$$



- ▶ Collinear partons not separately resolvable
- ▶ Introduce finite resolution criterion, e.g.  $t > t_c$

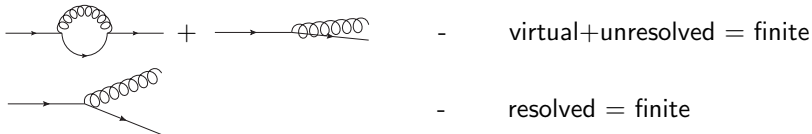

- ▶ **Unitarity / Probability conservation**  $\rightarrow$  resolved + unresolved = 1
- ▶ **Must implement no-emission probability (Poisson statistics)**

$$d\mathcal{P}_{\text{emit}}(t) = \frac{dt}{t} \int dz \frac{\alpha_s}{2\pi} P_{ab}(z) \quad \rightarrow \quad \mathcal{P}_{\text{no}}(t, t') = \exp \left\{ - \int_t^{t'} \frac{d\bar{t}}{\bar{t}} \int dz \frac{\alpha_s}{2\pi} P_{ab}(z) \right\}$$

- ▶ Call  $\Delta(t, t') := \mathcal{P}_{\text{no}}(t, t')$  the Sudakov form factor
- ▶ Total probability for parton produced at  $t'$  to radiate at  $t$  is

$$d\mathcal{P}(t) = d\mathcal{P}_{\text{emit}}(t) \mathcal{P}_{\text{no}}(t, t') = dt \frac{d\Delta(t, t')}{dt}$$

[Sjöstrand] PLB175(1985)321

- ▶ Iteration leads to tree-like approximation of higher-order configuration
- ▶ Slight difference between final-state and initial-state evolution

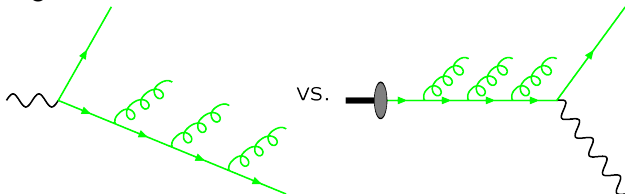

- ▶ Initial-state emission probability must account for probability to resolve (different) parton at larger  $x$

$$d\mathcal{P}_{\text{emit}}(x, t) = \frac{dt}{t} \int \frac{dz}{z} \frac{\alpha_s}{2\pi} P_{ab}(z) \frac{f_b(x/z, t)}{f_a(x, t)}$$

- ▶ Hard to implement in forward evolution (increasing  $t$ )
- ▶ Standard method is to evolve backward in initial state

[Marchesini,Webber] NPB310(1988)461

- ▶ Gluons with large wavelength not capable of resolving charges of emitting color dipole individually

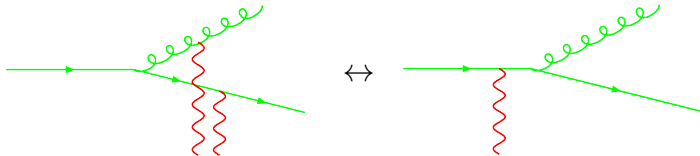

- ▶ Emission occurs with combined charge of mother parton instead
- ▶ Net effect is destructive interference outside cone with opening angle defined by emitting color dipole
- ▶ Can be implemented directly by angular ordering variable or additional ordering criterion in parton showers

- ▶ Color coherence observed experimentally in 3-jet events
- ▶ Purely virtuality ordered PS's produce too much radiation in central region
- ▶ Angular ordered / angular vetoed PS's ok

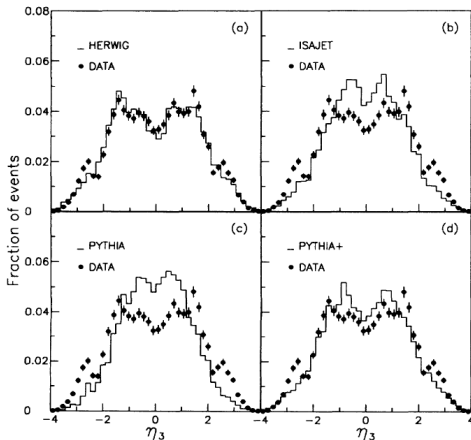
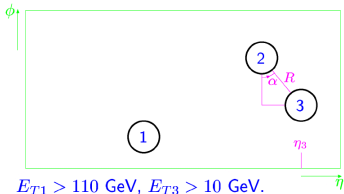

- ▶ In parton showers, the collinear/soft limit is never reached  
But who absorbs recoil when a splitting parton goes off mass-shell?
- ▶ No answer in DGLAP evolution equations  $\leftrightarrow$  collinear limit  
Ambiguity introduces large uncertainties, especially at large  $t$
- ▶ Natural solution provided by  $2 \rightarrow 3$  splittings  
Spectator kinematics enters splitting probability
- ▶ Basic concept of dipole showers

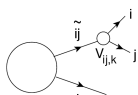

final-final

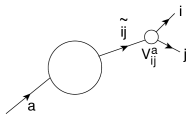

final-initial

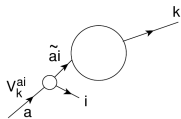

initial-final

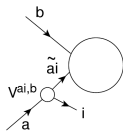

initial-initial

► Publicly available generators

	Evolution variable	Splitting variable	Coherence
Ariadne	dipole- $k_{\perp}^2$	Rapidity	Antenna
Herwig	$E^2\theta^2_{\perp}$	Energy fraction	AO
Herwig++	$(t - m^2)/z(1 - z)$	LC mom fraction	AO/Dipole
Pythia <6.4	$t$	Energy fraction	Enforced
Pythia $\geq 6.4$	$k_{\perp}^2$	LC mom fraction	Enforced
Sherpa <1.2	$t$	Energy fraction	Enforced
Sherpa $\geq 1.2$	$k_{\perp}^2$	LC mom fraction	Dipole
Vincia	variable	variable	Antenna

Durham 2-jet rate  $R_2$  @ LEP1

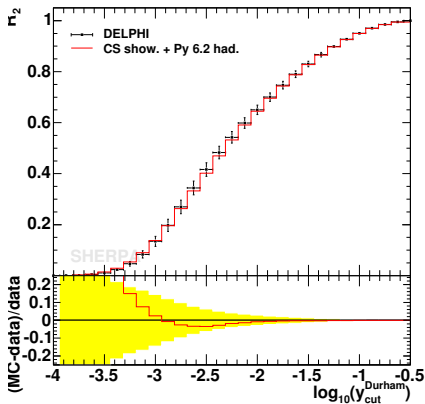

Durham 3-jet rate  $R_3$  @ LEP1

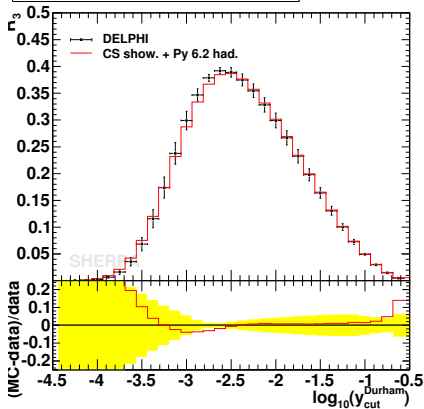

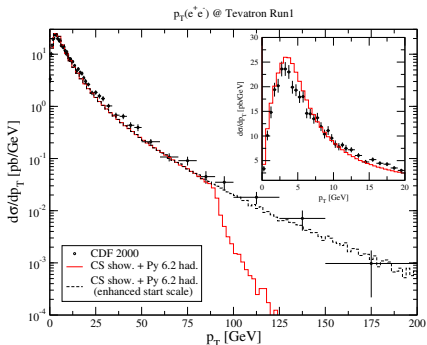

- ▶ Example: Drell-Yan lepton pair production at Tevatron
- ▶ If ME computed at leading order, then parton shower is only source of transverse momentum



- ▶ Hard interaction
- ▶ QCD evolution
- ▶ Secondary hard interactions
- ▶ Hadronization
- ▶ Hadron decays
- ▶ Higher-order QED corrections

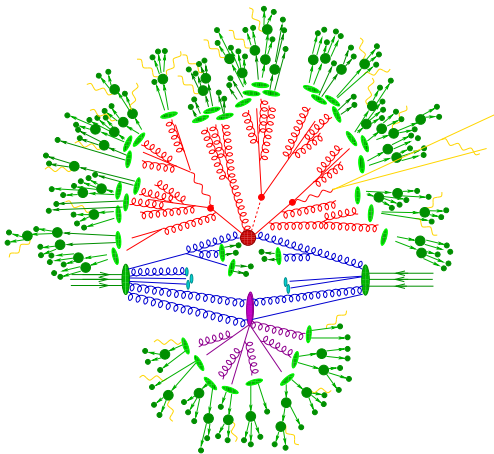

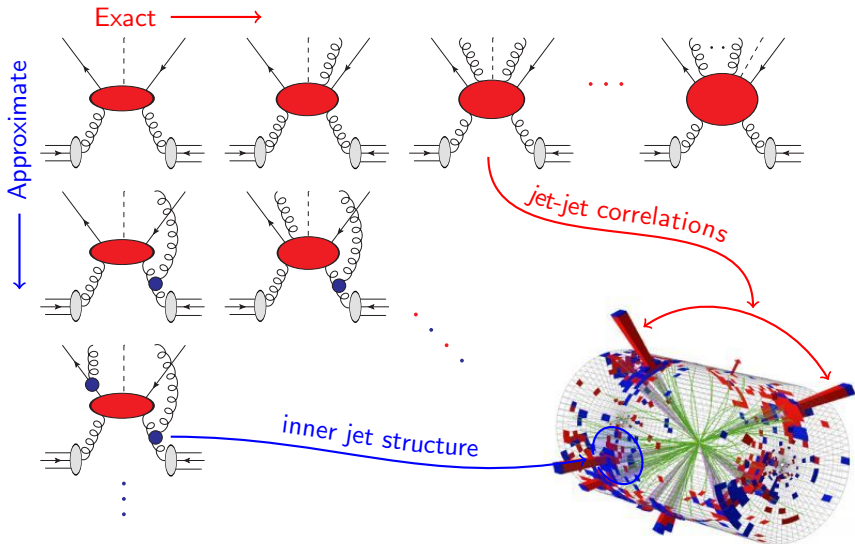

Merging related  
Matching related

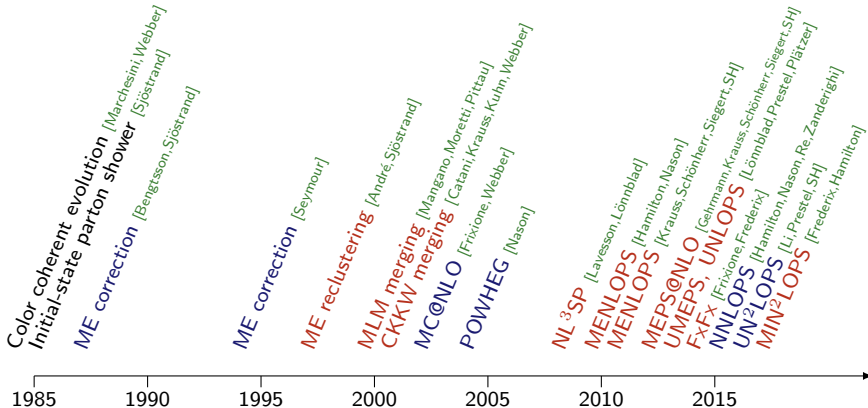

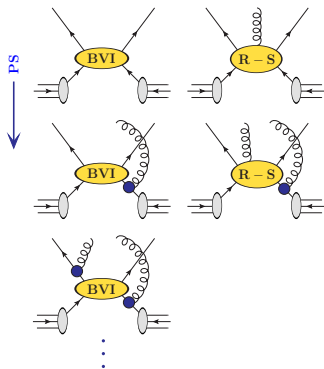

[Frixione, Webber] hep-ph/0204244

- ▶ Revisit toy model for NLO

$$\langle O \rangle = (B + V + I) O(0) + \int_0^1 \frac{dx}{x} [R(x) O(x) - S O(0)]$$

- ▶ In parton showers, any number of “photons” can be emitted
- ▶ Emission probability controlled by Sudakov form factor

$$\Delta(x_1, x_2) = \exp \left\{ - \int_{x_1}^{x_2} \frac{dx}{x} K(x) \right\}$$

Evolution kernel behaves as  $\lim_{x \rightarrow 0} K(x) = \lim_{x \rightarrow 0} R(x)/B = C$

- ▶ Define generating functional of PS  $\rightarrow$

$$\mathcal{F}_{\text{MC}}^{(n)}(x) \leftrightarrow \text{PS starting from } n \text{ emissions at } x$$

- ▶  $\mathcal{F}_{\text{MC}}^{(n)}(x, O)$  now replaces observable  $O$  Naively:

$$O(0) \Leftrightarrow \text{start MC with 0 emissions} \rightarrow \mathcal{F}_{\text{MC}}^{(0)}(O)$$

$$O(x) \Leftrightarrow \text{start MC with 1 emission} \rightarrow \mathcal{F}_{\text{MC}}^{(1)}(x, O)$$

- ▶ Combined generating functional would be

$$\left[ (B + V + I) - \int_0^1 \frac{dx}{x} S \right] \mathcal{F}_{\text{MC}}^{(0)}(O) + \int_0^1 \frac{dx}{x} R(x) \mathcal{F}_{\text{MC}}^{(1)}(x, O)$$

- ▶ This is wrong because

$$\mathcal{F}_{\text{MC}}^{(0)}(O) = \Delta(x_c, 1) O(0) + \int_{x_c}^1 \frac{dx}{x} K(x) \Delta(x, 1) O(x) + \dots$$

- ▶ So  $B \mathcal{F}_{\text{MC}}^{(0)}$  generates an  $\mathcal{O}(\alpha)$  term that spoils NLO accuracy

$$\left( \frac{d\sigma}{dx} \right)_{\text{MC}} O(x) = B \left[ - \frac{K(x)}{x} O(0) + \frac{K(x)}{x} O(x) \right]$$

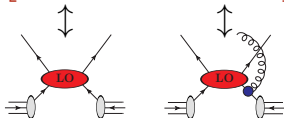

- ▶ The proper MC@NLO is obtained by subtracting this  $\mathcal{O}(\alpha)$  contribution

$$\mathcal{F}_{\text{MC@NLO}}(O) = \underbrace{\left[ (B + V + I) + \int_0^1 \frac{dx}{x} (BK(x) - S) \right]}_{\text{NLO-weighted Born cross section}} \mathcal{F}_{\text{MC}}^{(0)}(O) + \int_0^1 \frac{dx}{x} \underbrace{[R(x) - BK(x)]}_{\text{modified subtraction}} \mathcal{F}_{\text{MC}}^{(1)}(x, O)$$

- ▶ Like at fixed order, both terms are separately finite
- ▶ We call events from the first term **S-events** (Standard) and events from the second term **H-events** (Hard)
- ▶ For further reference, define  $D^{(K)}(x) := BK(x)$  as well as

$$\bar{B}^{(K)} = (B + V + I) + \int_0^1 \frac{dx}{x} (D^{(K)}(x) - S), \quad H^{(K)}(x) = R(x) - D^{(K)}(x)$$

→ compact notation

$$\mathcal{F}_{\text{MC@NLO}}(O) = \bar{B}^{(K)} \mathcal{F}_{\text{MC}}^{(0)}(O) + \int_0^1 \frac{dx}{x} H^{(K)}(x) \mathcal{F}_{\text{MC}}^{(1)}(x, O)$$

[Frixione, Webber] hep-ph/0204244

- ▶ Apply toy model to QCD, but include  $1/x$ -terms in coefficient functions  
Also need to sum over all flavor contributions at real-emission level

$$\bar{B}_n^{(K)}(\Phi_n) = \left( B_n(\Phi_n) + \tilde{V}_n(\Phi_n) + I_n(\Phi_n) \right) + \int d\Phi_1 \left( D_n^{(K)}(\Phi_{n+1}) - S_n(\Phi_{n+1}) \right)$$

$$H_n^{(K)}(\Phi_{n+1}) = R_n(\Phi_{n+1}) - D_n^{(K)}(\Phi_{n+1})$$

- ▶ Full differential event rate up to first emission

$$d\sigma_{\text{MC@NLO}} = d\Phi_n \bar{B}_n^{(K)}(\Phi_n) \left[ \Delta_n^{(\text{PS})}(t_c, \mu_Q^2) \leftrightarrow \text{B} \right] + \int_{t_c}^{\mu_Q^2} d\Phi_1 K_n(\Phi_1) \Delta_n^{(\text{PS})}(t(\Phi_1), \mu_Q^2) \left[ \text{B} \right] + d\Phi_n \int d\Phi_1 H_n^{(K)}(\Phi_{n+1}) \left[ \text{LO} \right]$$



[Nason,Webber] arXiv:1202.1251

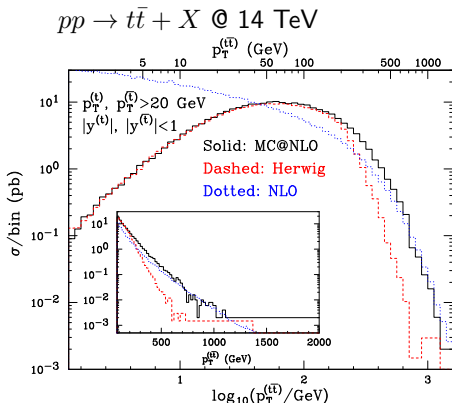

- MC@NLO interpolates smoothly between real-emission ME and PS

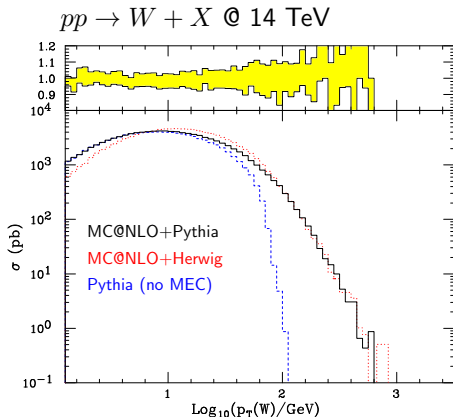

- ▶ MC@NLO with different PS agree at high  $p_T \leftrightarrow$  NLO
- ▶ Differences at low  $p_T$  due to differences in PS

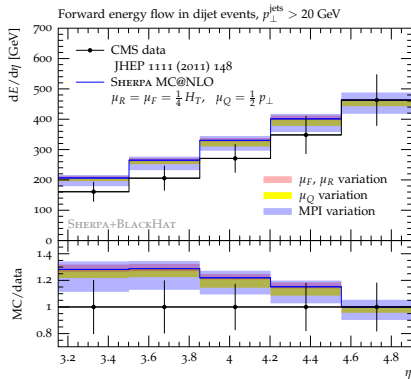
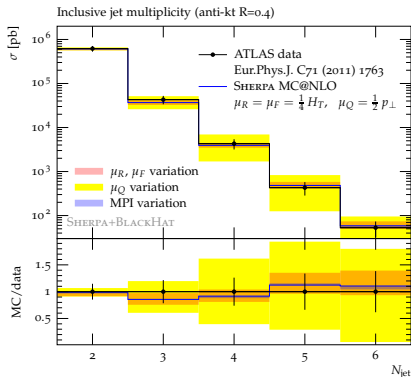
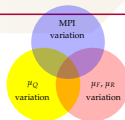

- ▶ Jet multiplicity  $\rightarrow$  uncertainty due to choice of  $\mu_Q^2$
- ▶ Forward energy flow  $\rightarrow$  major uncertainty from underlying event

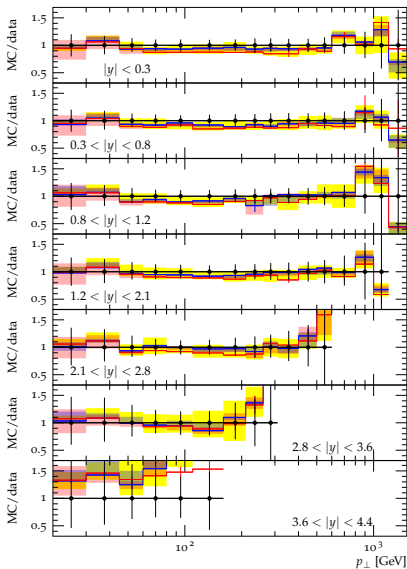
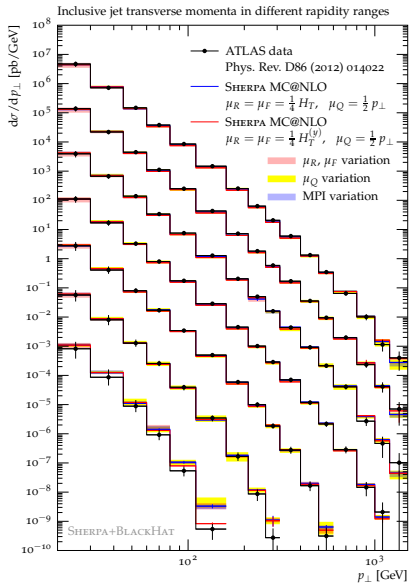

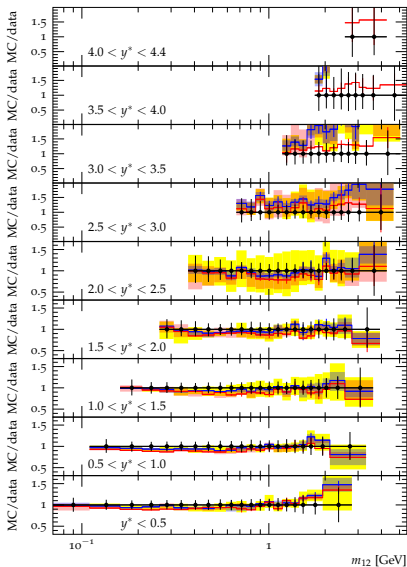
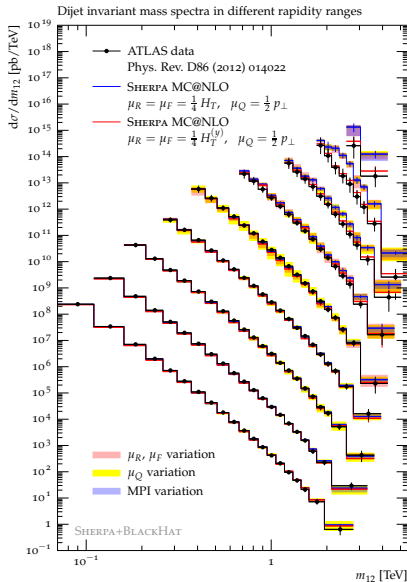

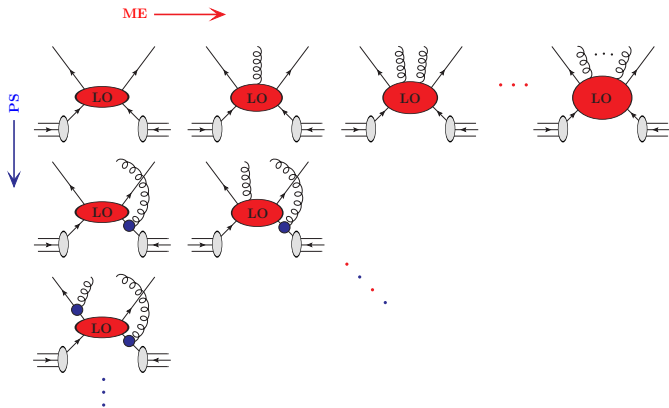

- ▶ Separate phase space into “hard” and “soft” region
- ▶ Matrix elements populate hard domain
- ▶ Parton shower populates soft domain
- ▶ Need criterion to define “hard” & “soft”  
→ jet measure  $Q$  and corresponding cut,  $Q_{\text{cut}}$

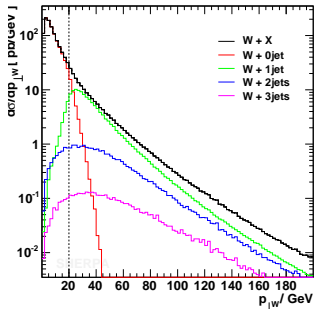

[André,Sjöstrand] hep-ph/9708390

- ▶ Start with some “core” process for example  $e^+e^- \rightarrow q\bar{q}$
- ▶ This process is considered inclusive It sets the resummation scale  $\mu_Q^2$
- ▶ Higher-multiplicity ME can be reduced to core by clustering
- ▶ If we want to match ME & PS the correct clustering algorithm suggests itself
  - ▶ Identify most likely splitting according to PS emission probability
  - ▶ Combine partons into mother according to PS kinematics
  - ▶ Continue until core process

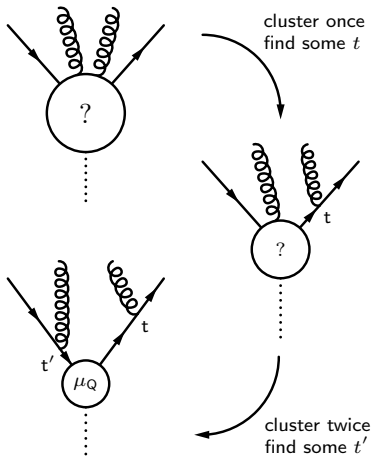



Efficient scheme to compute Sudakov suppression: Pseudo-showers

- ▶ Start PS from core process
- ▶ Evolve until predefined branching  
↔ truncated parton shower
- ▶ Emissions that would produce additional hard jets  
lead to event rejection (veto)

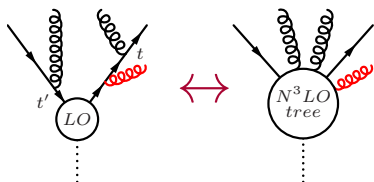

This corresponds to computing a Sudakov form factor given by

$$\Delta_n^{(\text{PS})}(t, \mu_Q^2; > Q_{\text{cut}}) = \exp \left\{ - \int_t^{\mu_Q^2} d\Phi_1 K_n(\Phi_1) \Theta(Q - Q_{\text{cut}}) \right\}$$

- ▶ Observable  $O$  to  $\mathcal{O}(\alpha_s)$  given by

$$\langle O \rangle = \int d\Phi_B B(\Phi_B) \left[ \Delta^{(K)}(t_c, \mu_Q^2) O(\Phi_B) \right. \\ \left. + \int_{t_c}^{\mu_Q^2} d\Phi_1 K(\Phi_1) \Delta^{(K)}(t(\Phi_1), \mu_Q^2) \Theta(Q_{\text{cut}} - Q) O(\Phi_R) \right] \\ + \int d\Phi_R R(\Phi_R) \Delta^{(K)}(t(\Phi_R), \mu_Q^2; > Q_{\text{cut}}) \Theta(Q - Q_{\text{cut}}) O(\Phi_R)$$

- ▶ Jet veto in PS
- ▶ Jet cut on  $n + 1$ -parton final state

## Algorithms with

- ▶ Exact correspondence between clustering & PS evolution
- ▶ Sudakov form factors as defined in parton shower

## CKKW-L (Pythia)

[Lönnblad] hep-ph/0112284

[Lönnblad,Prestel] arXiv:1109.4829

- ▶ Truncated showers generate suppression, but no emissions
- ▶ Jet criterion dynamically redefined during PS evolution

## METS (Herwig, Sherpa)

[SH,Krauss,Schumann,Siebert] arXiv:0903.1219

[Hamilton,Richardson,Tully] arXiv:0905.3072

- ▶ Truncated parton showers generate emissions and suppression
- ▶ Accounts for mismatch between jet criterion and evolution variable

## Algorithms with

- ▶ Approximate correspondence between clustering & PS evolution
- ▶ Approximate Sudakov form factors

## MLM

[Mangano,Moretti,Pittau] hep-ph/0108069

[Mangano,Moretti,Piccinini,Treccani] hep-ph/0611129

- ▶ No truncated parton showers, evolution starts at highest scale
- ▶ Sudakov suppression achieved by jet matching

## CKKW

[Catani,Krauss,Kuhn,Webber] hep-ph/0109231

[Krauss] hep-ph/0205283

- ▶ No truncated parton showers, evolution starts at modified scales
- ▶ Sudakov suppression by reweighting with NLL-approximated Sudakov

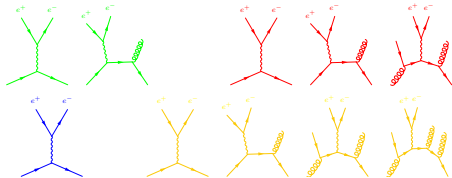
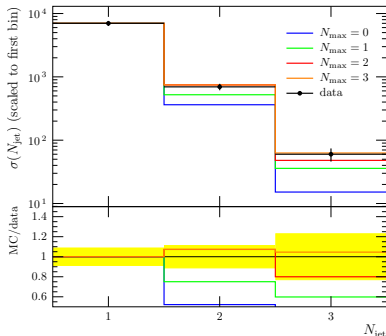

- MC predictions for exclusive  $n$ -jet rates match data well as long as corresponding final states are described by matrix elements

[ATLAS] arXiv:1108.6308 arXiv:1107.2381

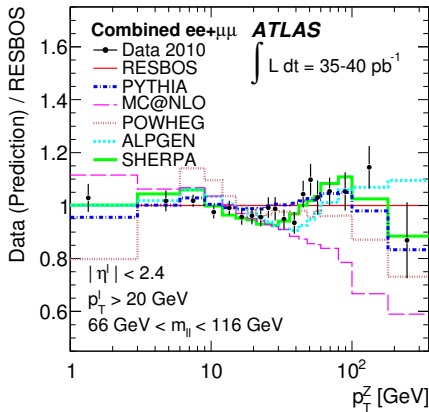
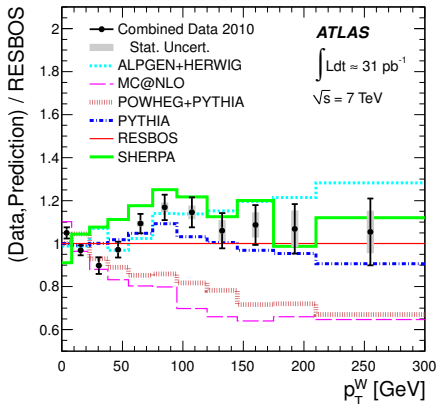

► Comparison of vector boson transverse momentum spectra

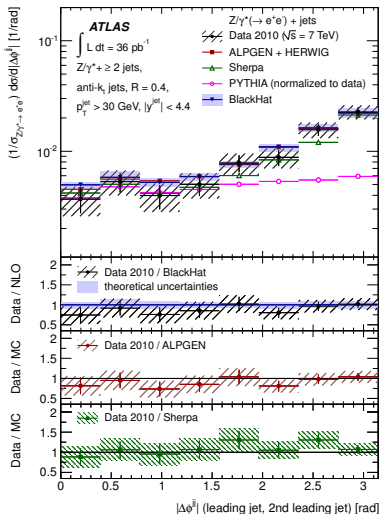
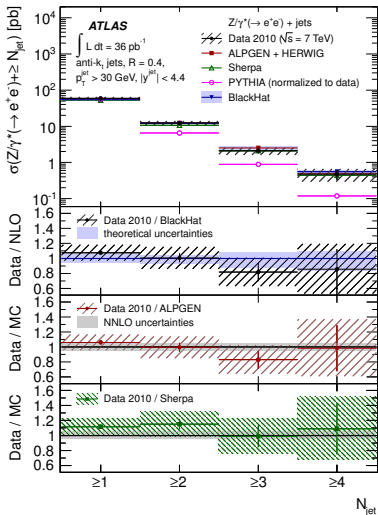

- ▶ Good agreement with both ALPGEN (MLM) and Sherpa
- ▶ PS alone fails for  $n_{\text{jet}} \geq 2$

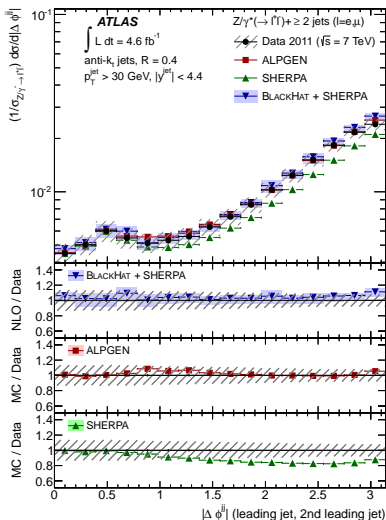
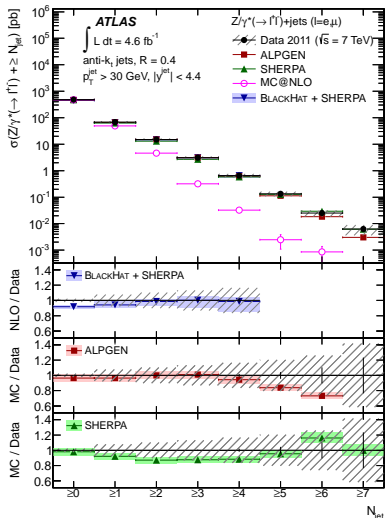

- ▶ Good agreement with ALPGEN (MLM), not so good with Sherpa
- ▶ MC@NLO alone fails for  $n_{\text{jet}} > 2$



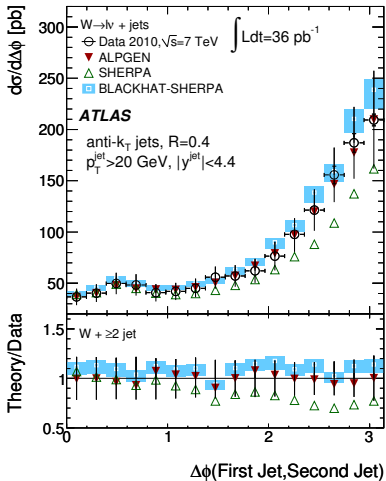
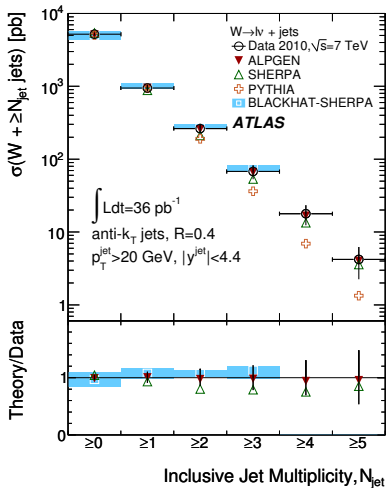

► Good agreement with ALPGEN (MLM), not so good with Sherpa



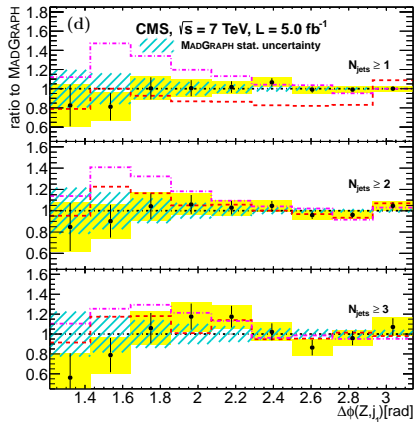
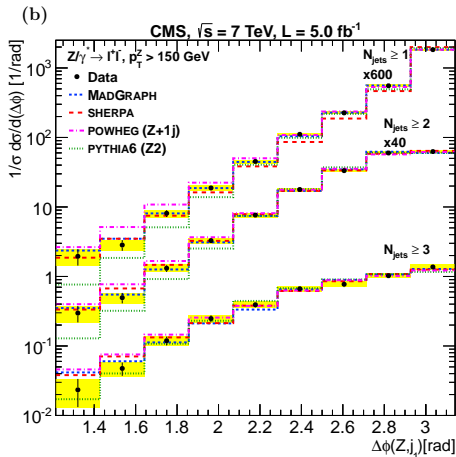

- Azimuthal separation between Z-boson and leading jet
- Boosted event sample

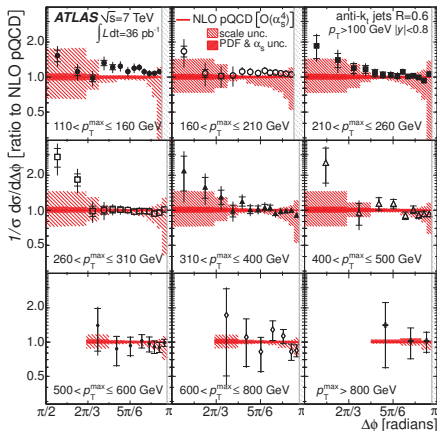
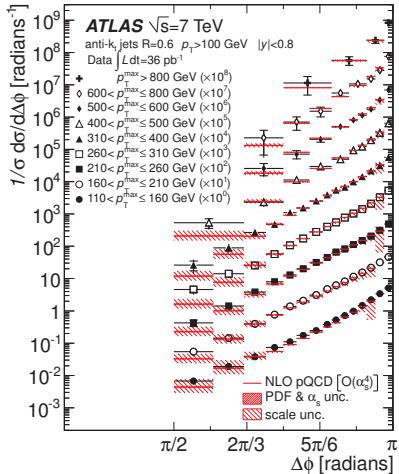

[ATLAS] arXiv:1102.2696

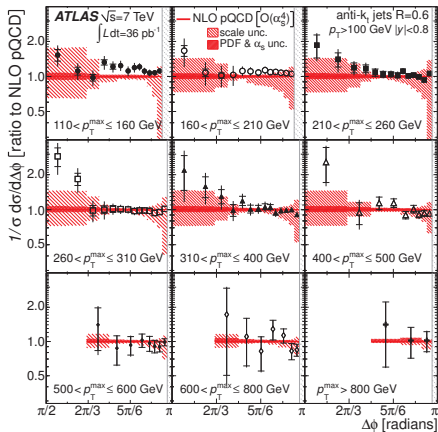
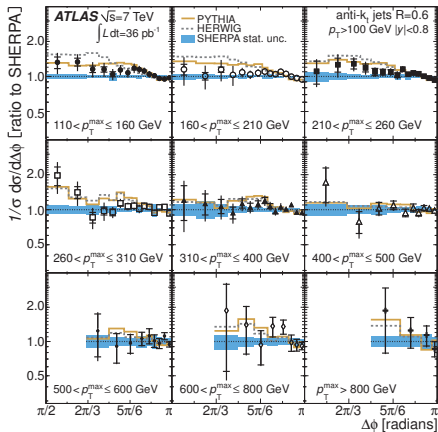

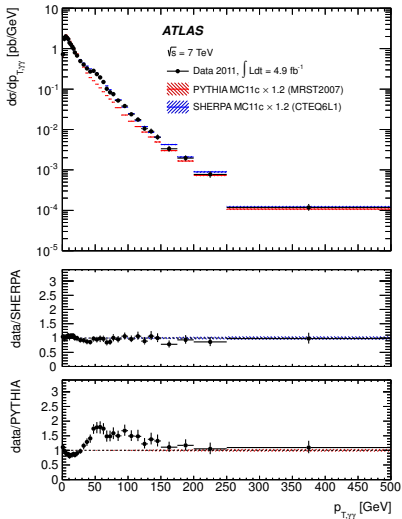
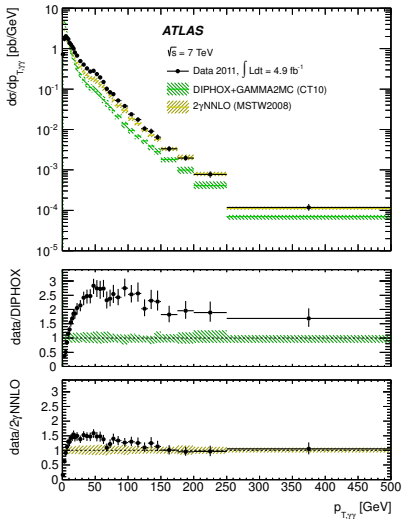

[ATLAS] arXiv:1211.1913

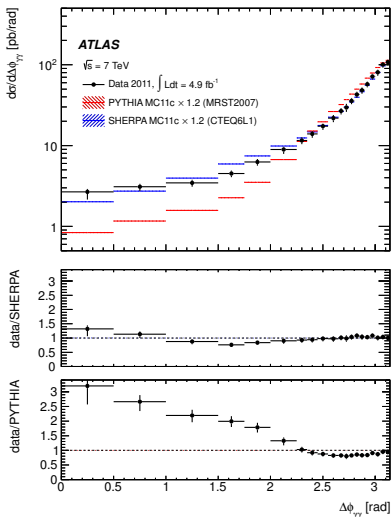
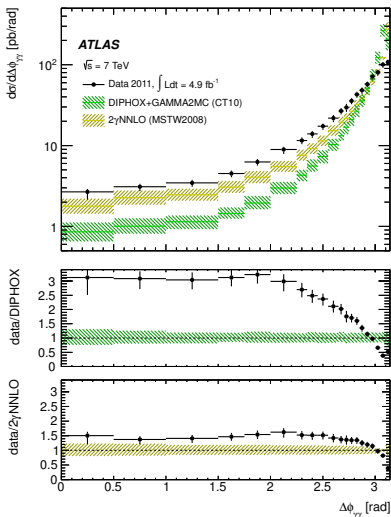

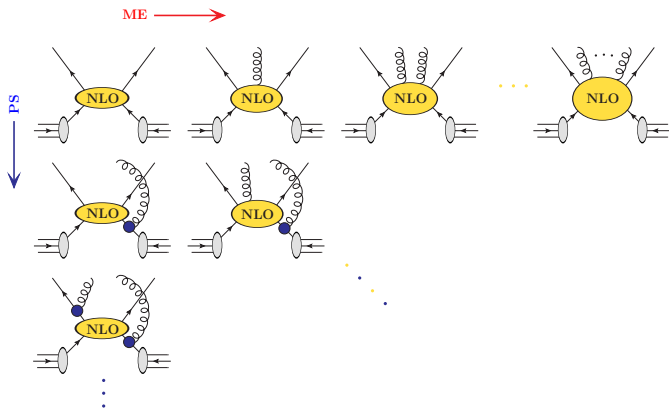



[Lavesson,Lönnblad,Prestel] arXiv:0811.2912 arXiv:1211.7278  
 [Gehrmann,Krauss,Schönherr,Siegert,SH] arXiv:1207.5031 arXiv:1207.5030  
 [Frederix,Frixione] arXiv:1209.6215

- ▶ MEPS for 0+1-jet in MC@NLO notation

$$\langle O \rangle = \int d\Phi_B B(\Phi_B) \left[ \Delta^{(K)}(t_c) O(\Phi_B) + \int_{t_c} d\Phi_1 K(\Phi_1) \Delta^{(K)}(t) \Theta(Q_{\text{cut}} - Q) O(\Phi_R) \right] \\ + \int d\Phi_R R(\Phi_R) \Delta^{(K)}(t(\Phi_R); > Q_{\text{cut}}) \Theta(Q - Q_{\text{cut}}) O(\Phi_R)$$

- ▶ Reorder by parton multiplicity  $k$ , change notation  $R_k \rightarrow B_{k+1}$
- ▶ Analyze exclusive contribution from  $k$  hard partons only ( $t_0 = \mu_Q^2$ )

$$\langle O \rangle_k^{\text{excl}} = \int d\Phi_k B_k \prod_{i=0}^{k-1} \Delta_i^{(K)}(t_{i+1}, t_i; > Q_{\text{cut}}) \Theta(Q_k - Q_{\text{cut}}) \\ \times \left[ \Delta_k^{(K)}(t_c, t_k) O_k + \int_{t_c}^{t_k} d\Phi_1 K_k \Delta_k^{(K)}(t_{k+1}, t_k) \Theta(Q_{\text{cut}} - Q_{k+1}) O_{k+1} \right]$$

- Analyze exclusive contribution from  $k$  hard partons

$$\begin{aligned}
 \langle O \rangle_k^{\text{excl}} &= \int d\Phi_k \bar{B}_k^{(D)} \prod_{i=0}^{k-1} \Delta_i^{(K)}(t_{i+1}, t_i; > Q_{\text{cut}}) \Theta(Q_k - Q_{\text{cut}}) \\
 &\times \left( 1 + \frac{B_k}{\bar{B}_k^{(D)}} \sum_{i=0}^{k-1} \int_{t_{i+1}}^{t_i} d\Phi_1 K_i \Theta(Q_i - Q_{\text{cut}}) \right) \\
 &\times \left[ \Delta_k^{(D)}(t_c, t_k) O_k + \int_{t_c}^{t_k} d\Phi_1 K_k \Delta_k^{(D)}(t_{k+1}, t_k) \Theta(Q_{\text{cut}} - Q_{k+1}) O_{k+1} \right] \\
 &+ \int d\Phi_{k+1} H_k^{(D)} \Delta_k^{(K)}(t_k; > Q_{\text{cut}}) \Theta(Q_k - Q_{\text{cut}}) \Theta(Q_{\text{cut}} - Q_{k+1}) O_{k+1}
 \end{aligned}$$

- PS evolution kernels  $\rightarrow$  dipole terms
- Born matrix element  $\rightarrow$  NLO-weighted Born
- Add hard remainder function
- Subtract  $\mathcal{O}(\alpha_s)$  terms contained in truncated PS

[Lavesson, Lönnblad] arXiv:0811.2912

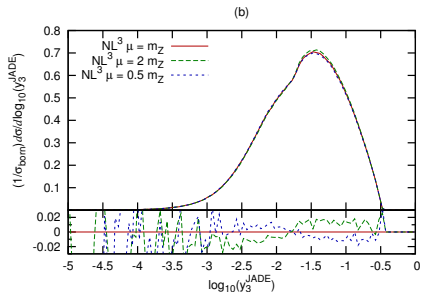
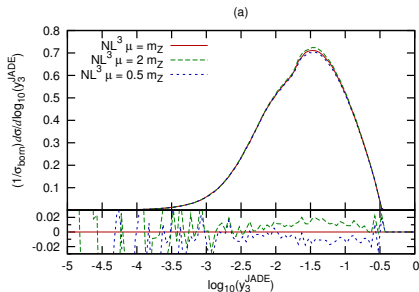

- ▶ Scale variations around 2%
- ▶ Agreement between 1- and 2-loop but no further reduction of uncertainty

[Gehrmann, Krauss, Schönherr, Siegert, SH] arXiv:1207.5031

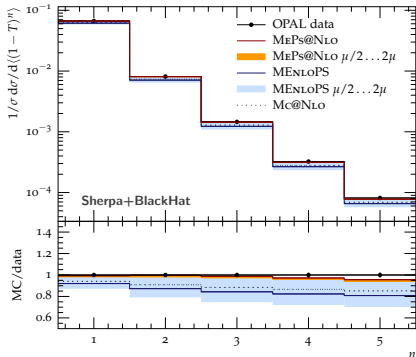
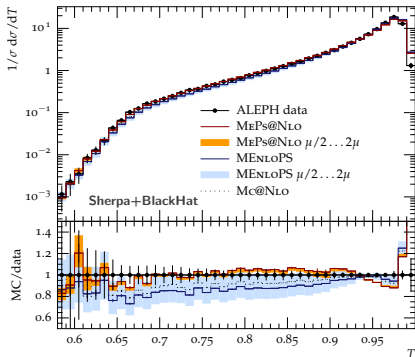

- ▶ Thrust & its moments
- ▶ MEPS@NLO with 2,3&4 jet PL at NLO plus 5&6 jet PL at LO vs MENLOPS with up to 6 jets at LO

[Gehrmann, Krauss, Schönherr, Siegert, SH] arXiv:1207.5031

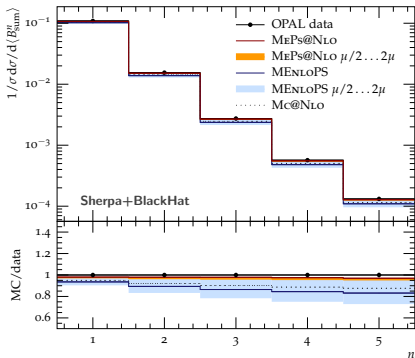
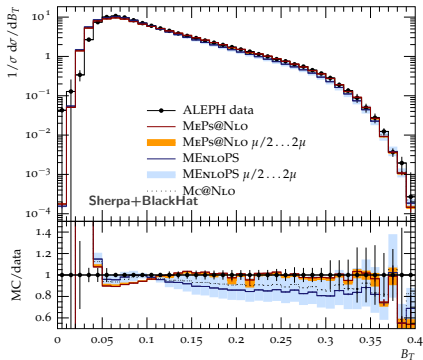

- ▶ Total jet broadening & its moments
- ▶ MEPS@NLO with 2,3&4 jet PL at NLO plus 5&6 jet PL at LO vs MENLOPS with up to 6 jets at LO

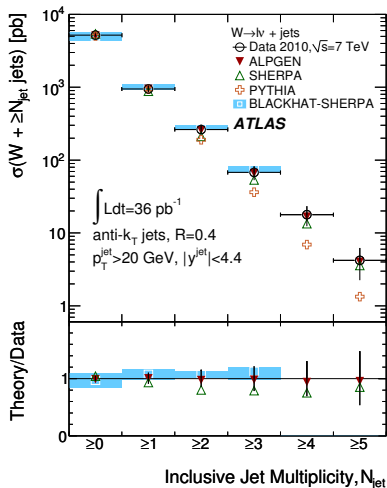

[ATLAS] arXiv:1201.1276  
 [SH,Krauss,Schönherr,Siebert] arXiv:1207.5030

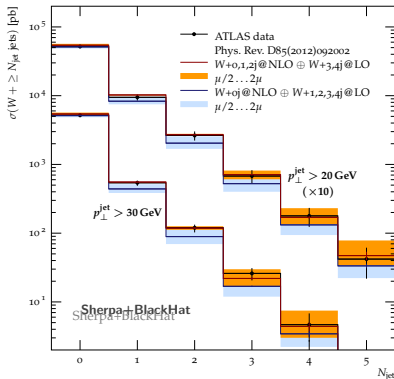

- ▶ MEPS@NLO with 0,1&2 jet PL at NLO plus 3&4 jet PL at LO
- ▶ MENLOPS with up to 4 jets at LO

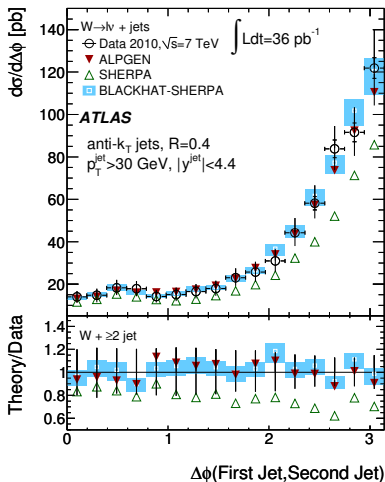

[ATLAS] arXiv:1201.1276  
 [SH, Krauss, Schönherr, Siegert] arXiv:1207.5030

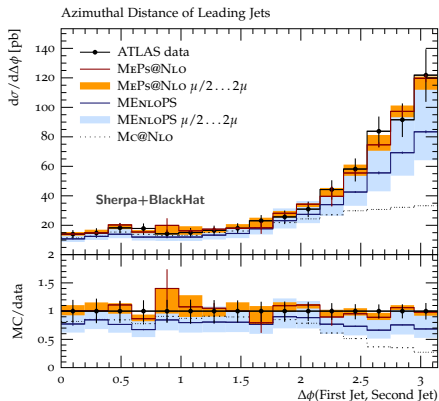

- ▶ MEPS@NLO with 0,1&2 jet PL at NLO plus 3&4 jet PL at LO
- ▶ MENLOPS with up to 4 jets at LO

[Les Houches SM WG] arXiv:1605.04692

- ▶ Setup
  - ▶ Stable Higgs
  - ▶ anti- $k_T$  jets,  $R = 0.4$ ,  $p_{T,j} > 30$  GeV  $|\eta_j| < 4.4$
- ▶ Calculations & tools in the comparison
  - ▶ Fixed-order NLO for  $h + \leq 3$  jets,  $H'_T/2$  & MINLO
  - ▶ LoopSim
  - ▶ NNLO for  $pp \rightarrow h$  (Sherpa),  $pp \rightarrow h + j$  (BFGLP)
  - ▶ Resummed  $h$ - $p_T$  (HqT & ResBos)
  - ▶ Resummed jet veto cross section (STWZ)
  - ▶ NNLO+PS (POWHEG & Sherpa)
  - ▶ Multi-jet merging up to 2 jets at NLO (Madgraph5\_aMC@NLO, Herwig 7.1)
  - ▶ Multi-jet merging up to 3 jets at NLO (Sherpa)
  - ▶ High-energy resummation (HEJ)



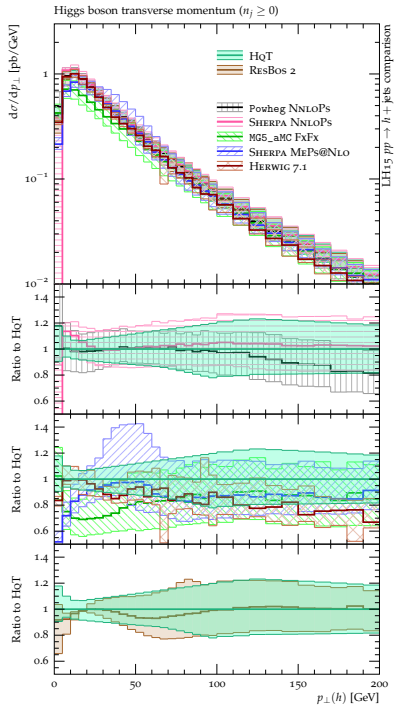
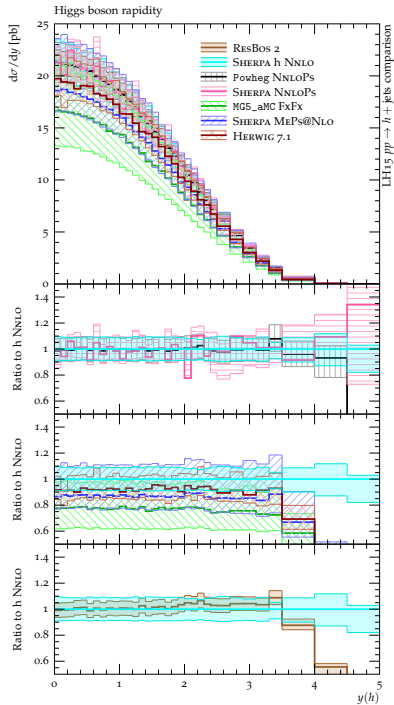

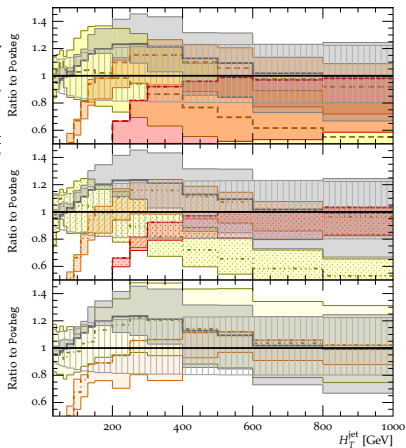
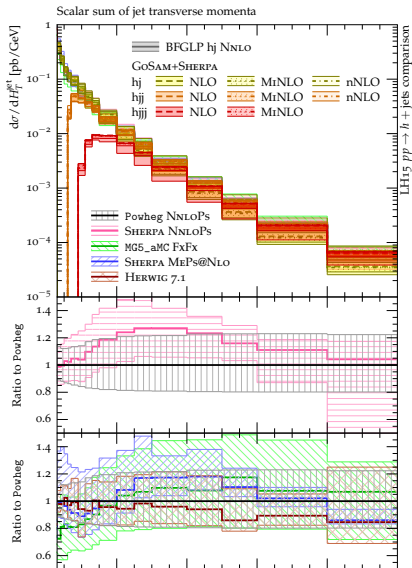

[Les Houches SM WG] arXiv:1605.04692

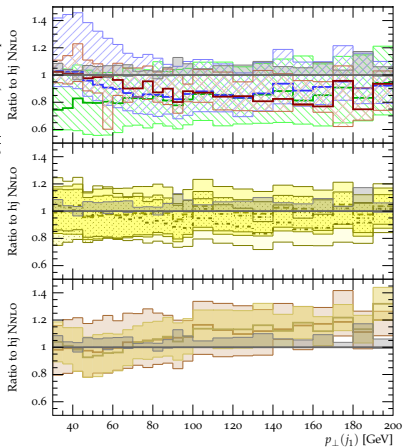
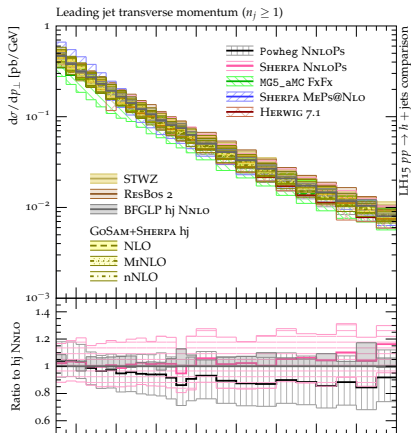

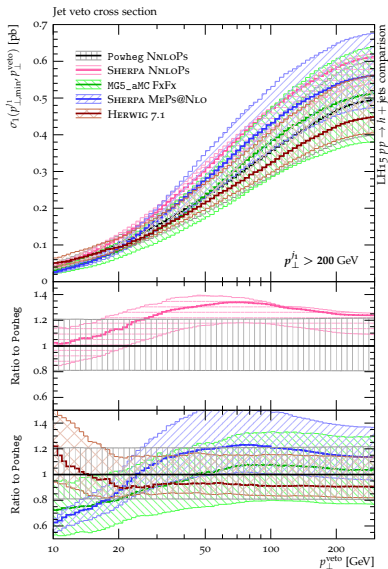
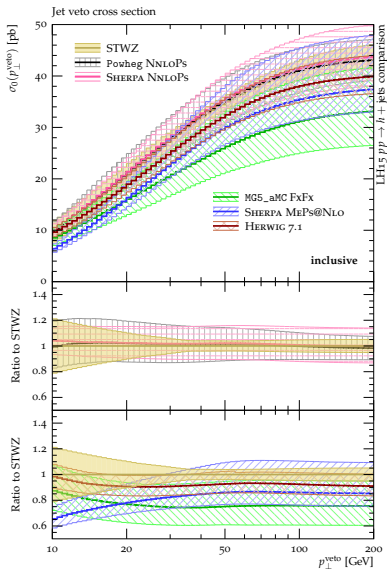

- ▶ Hard interaction
- ▶ QCD evolution
- ▶ Secondary hard interactions
- ▶ Hadronization
- ▶ Hadron decays
- ▶ Higher-order QED corrections

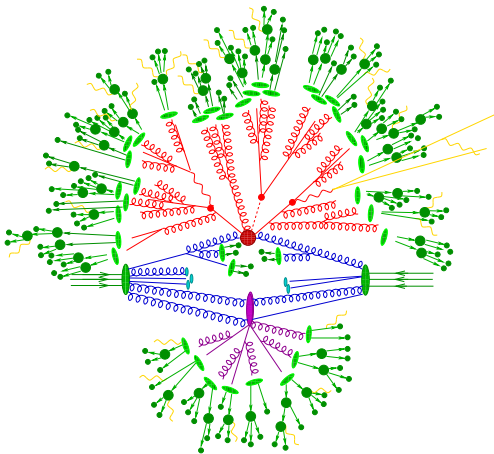

► Soft inclusive collision

$$\sigma_{\text{tot}} = \sigma_{\text{elastic}} + \sigma_{\text{single diffractive}} + \sigma_{\text{double diffractive}} + \sigma_{\text{non-diffractive}}$$

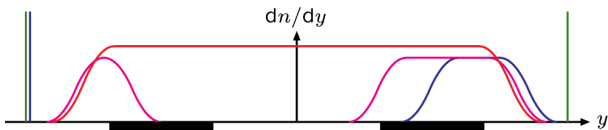

► Underlying event

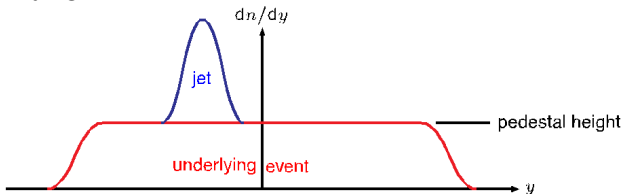

[Sjöstrand,Zijl] PRD36(1987)2019

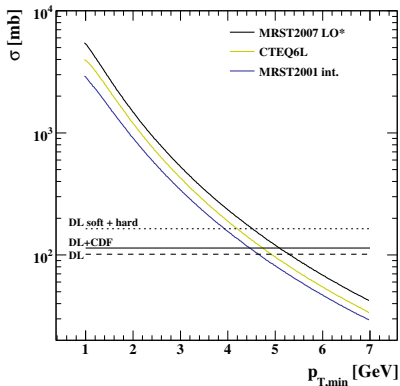

- ▶ Partonic cross sections diverge roughly like  $dp_T^2/p_T^4$
- ▶ Total cross section at LHC exceeded for  $p_T \approx 2-5$  GeV
- ▶ Interpretation as possibility for multiple hard scatters with

$$\langle n \rangle = \frac{\sigma_{\text{hard}}}{\sigma_{\text{non-diffractive}}}$$

- ▶ Main free parameter is  $p_{T,\text{min}}$   
Determines size of  $\sigma_{\text{hard}}$

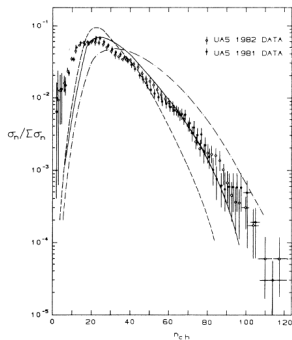

- ▶ Despite MPI wrong charged multi distribution Impact parameter dependent model needed
- ▶ Various hadron shape models in b-space (Exponential, Gaussian, double Gaussian)

$$\langle n \rangle = \frac{\sigma_{\text{hard}}}{\sigma_{\text{non-diffractive}}}$$



$$\langle \tilde{n}(b) \rangle = f_c f(b) \frac{\sigma_{\text{hard}}}{\sigma_{\text{non-diffractive}}}$$

- ▶ Hardness of the collision determines overlap Collisions with large overlap in turn have more secondary interactions

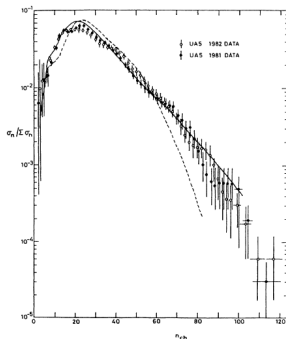



[Sjöstrand,Skands] hep-ph/0408302

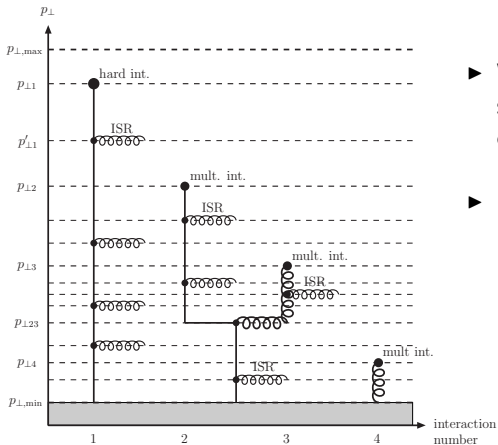

- ▶ When attaching IS shower to secondary scattering can ask at each point whether emission or new interaction is more likely
- ▶ **New evolution equation**

$$\frac{d\mathcal{P}}{dp_T} = \left( \frac{d\mathcal{P}_{MI}}{dp_T} + \frac{d\mathcal{P}_{ISR}}{dp_T} \right) \times \exp \left\{ - \int_{p_T} dp'_T \left( \frac{d\mathcal{P}_{MI}}{dp'_T} + \frac{d\mathcal{P}_{ISR}}{dp'_T} \right) \right\}$$

[Sjöstrand,Skands] hep-ph/0402078

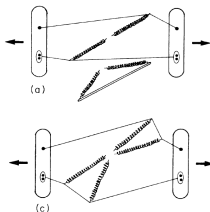

- ▶ New models embed scatters into existing color topology
- ▶ Three different options for string drawing
  - ▶ At random
  - ▶ Rapidity ordered
  - ▶ String length optimized

- ▶ Secondary scatterings need to be color-connected to something
- ▶ Simplest model would decouple them from proton remnants
- ▶ Next-to-simplest model would put all scatters on one color string

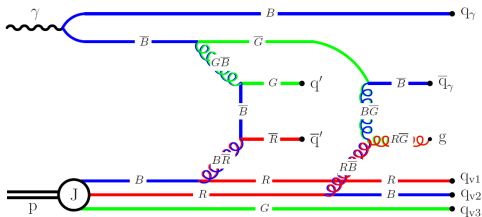

[Butterworth,Forshaw,Seymour] hep-ph/9601371

[Borozan,Seymour] hep-ph/0207283

- ▶ Assume parton distribution within beam hadron is

$$\frac{dn_a(x, \mathbf{b})}{d^2\mathbf{b}dx} = f_a(x) G(\mathbf{b})$$

- ▶ Use electromagnetic form factor

$$G(\mathbf{b}) = \int \frac{d^2\mathbf{k}}{(2\pi)^2} \frac{\exp(\mathbf{k} \cdot \mathbf{b})}{(1 + \mathbf{k}^2/\mu^2)^2}$$

- ▶ EM measurements indicate  $\mu_P = 0.71$  GeV  
 $\mu$  is however left free in model  $\rightarrow$  tuning
- ▶ Continue model below  $p_{T,\min}$  with same b-space parametrization  
but cross section as Gaussian in  $p_T \rightarrow$  inclusive non-diffractive events

- ▶ Hard interaction
- ▶ QCD evolution
- ▶ Secondary hard interactions
- ▶ **Hadronization**
- ▶ Hadron decays
- ▶ Higher-order QED corrections

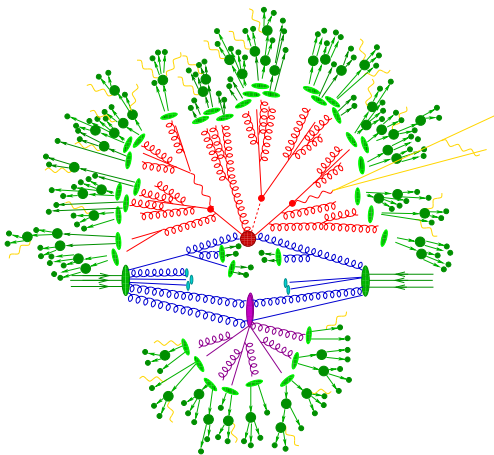

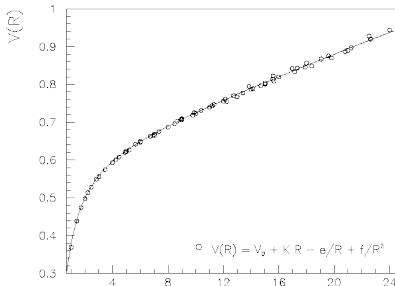
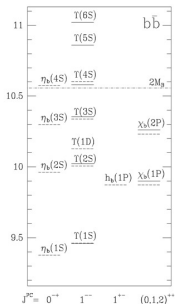
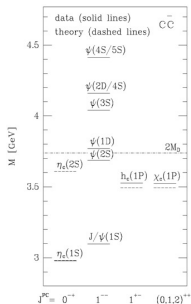

- ▶ Measure QCD potential from quarkonia masses
- ▶ Or compute using lattice QCD
- ▶ Approximately linear potential  $\leftrightarrow$  QCD flux tube

[Andersson, Gustafson, Ingelman, Sjöstrand] PR97(1983)31

- ▶ Start with example  $e^+e^- \rightarrow q\bar{q}$
- ▶ QCD flux tube with constant energy per unit rapidity  $\leftrightarrow$
- ▶ New  $q\bar{q}$ -pairs created by tunneling ( $\kappa$  - string tension)



$$\frac{d\mathcal{P}}{dxdt} = \exp\left\{-\frac{\pi^2 m_q^2}{\kappa}\right\}$$

- ▶ Expanding string breaks into hadrons, then yo-yo modes
- ▶ Baryons modeled as quark-diquark pairs

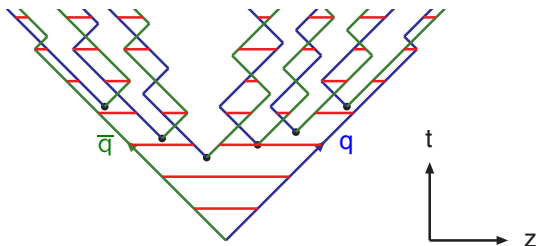

- ▶ String model very well motivated, but many parameters
- ▶ But also gives genuine prediction of “string effect”
- ▶ Gluons are kinks on string  
String accelerated in direction of gluon
- ▶ Infrared safe matching to parton showers  
Gluons with  $k_T \lesssim 1/\kappa$  irrelevant

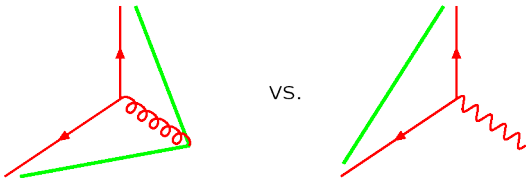

[Webber] NPB238(1984)492

- ▶ Underlying idea: Preconfinement
- ▶ Follow color structure of parton showers:  
color singlets end up close in phase space
- ▶ Mass of color singlets peaked at low scales ( $\approx t_c$ )

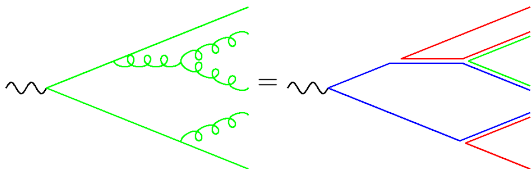



Primary Light Clusters

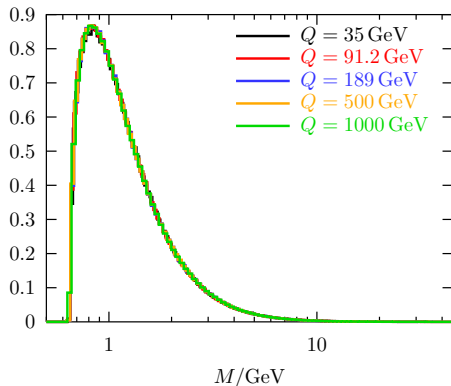

- Mass spectrum of primordial clusters independent of cm energy

## Naïve model

- ▶ Split gluons into  $q\bar{q}$ -pairs
- ▶ Color-adjacent pairs form primordial clusters
- ▶ Clusters decay into hadrons according to phase space  
→ baryon & heavy quark production suppressed

## Improved model

- ▶ Heavy clusters decay into lighter ones
- ▶ Three options:  $C \rightarrow CC$ ,  
 $C \rightarrow CH$  &  $C \rightarrow HH$
- ▶ Leading particle effects

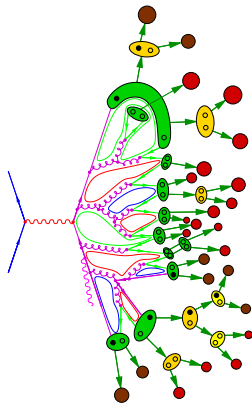

[T.Sjöstrand, Durham'09]

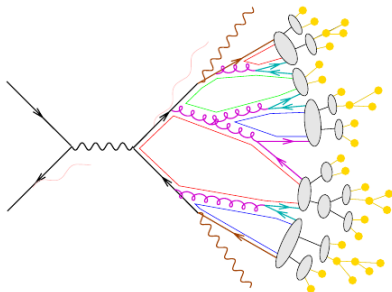
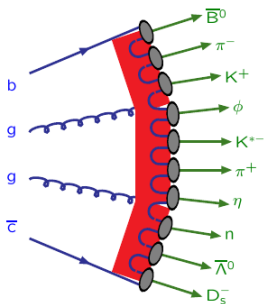

program	PYTHIA	HERWIG
model	string	cluster
energy-momentum picture	powerful	simple
parameters	predictive	unpredictive
flavour composition	few	many
parameters	messy	simple
	unpredictive	in-between
	many	few

“There ain't no such thing as a parameter-free *good* description”

- ▶ Hard interaction
- ▶ QCD evolution
- ▶ Secondary hard interactions
- ▶ Hadronization
- ▶ Hadron decays
- ▶ Higher-order QED corrections

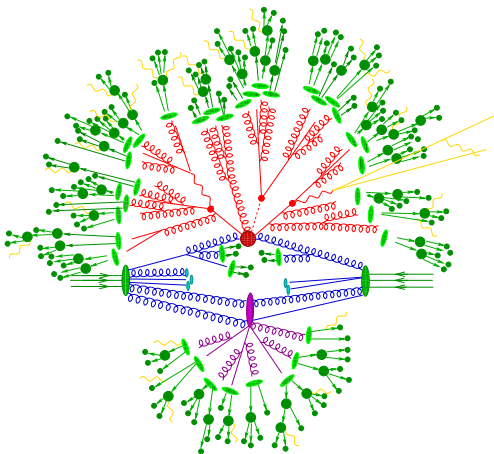

- ▶ String and clusters decay to some stable hadrons but main outcome are unstable resonances
- ▶ These decay further according to the PDG decay tables
- ▶ Many hadron decays according to phase space but also a large variety of form factors known
- ▶ Not all branching ratios known precisely plus many BR's in PDG tables do not add up to one
- ▶ Significant effect on hadronization yields, hadronization corrections to event shapes, etc.

- ▶ Previous generations of generators relied on external decay packages Tauola ( $\tau$ -decays) & EvtGen ( $B$ -decays)
- ▶ New generation programs Herwig++ & Sherpa contain at least as complete a description
- ▶ Spin correlations and B-mixing built in
- ▶ No interfacing issues
  
- ▶ Previous generations of generators relied on external package Photos to simulate QED radiation
- ▶ New generation programs Herwig++ & Sherpa have simulation of QED radiation built in

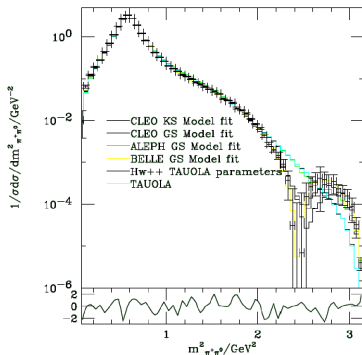

- ▶ Parton showers resum logarithmic corrections and generate exclusive radiation pattern
- ▶ Virtual corrections approximated by unitarity, can be included in full using MC@NLO
- ▶ POWHEG eliminates negative weight events in NLO matched simulations
- ▶ Large uncertainties associated with choice of resummed part of real correction

- ▶ ME+PS merging includes higher multiplicity matrix elements at tree-level
- ▶ NL<sup>3</sup>SP, MEPS@NLO & FxFx allow to merge NLO-matched simulations of anything+jets
- ▶ UNLOPS unitarises entire simulation
- ▶ Underlying event typically simulated by MPI can be combined with PS in common evolution
- ▶ Two models (string & cluster) for parton to hadron fragmentation



**Try your generator of choice during the tutorial!**

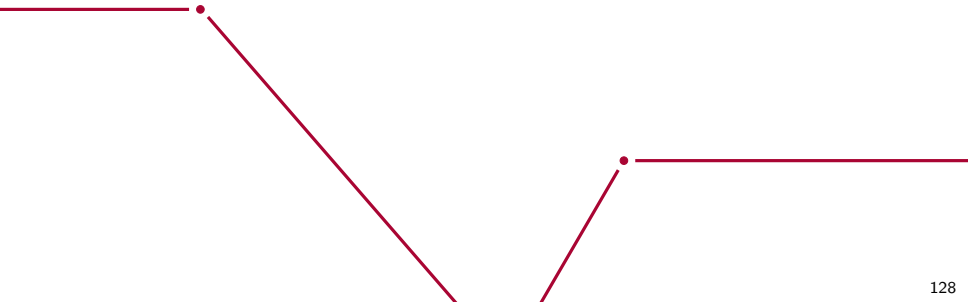

- ▶ Want to compute expectation values of observables

$$\langle O \rangle = \sum_n \int d\Phi_n P(\Phi_n) O(\Phi_n)$$

$\Phi_n$  - Point in  $n$ -particle phase-space

$P(\Phi_n)$  - Probability to produce  $\Phi_n$

$O(\Phi_n)$  - Value of observable at  $\Phi_n$

- ▶ Problem #1: Computing  $P(\Phi_n)$
- ▶ Problem #2: Performing the integral
- ▶ At LO and NLO problem #2 is harder to solve  
This is where MC event generators come in

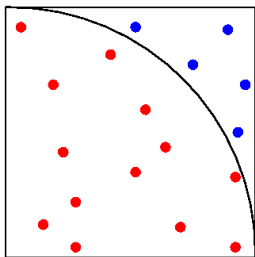

$$\frac{\text{Hits}}{\text{Misses} + \text{Hits}} \rightarrow \frac{\pi}{4}$$

Throw random points  $(x,y)$ ,  
with  $x, y$  in  $[0,1]$

For hits:  $(x^2 + y^2) < r^2 = 1$

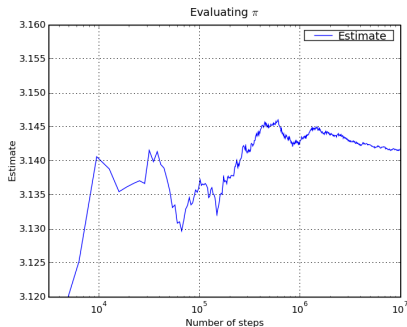

- ▶ In many cases we can approximate the integral of  $f(x)$  with some known function  $g(x)$  such that primitive  $G(x)$  is known
- ▶ This amounts to a variable transformation

$$I = \int_a^b dx g(x) \frac{f(x)}{g(x)} = \int_{G(a)}^{G(b)} dG(x) w(x) \quad \text{where} \quad w(x) = \frac{f(x)}{g(x)}$$

- ▶ Integral and error estimate are

$$I = [G(b) - G(a)] \langle w \rangle \quad \sigma = [G(b) - G(a)] \sqrt{\frac{\langle w^2 \rangle - \langle w \rangle^2}{N - 1}}$$

$N$  - Number of MC events (points)

- ▶ MC error scales as  $1/\sqrt{N}$   
independent of number of dimensions!
- ▶ Note that  $I$  is independent of  $g(x)$ , but  $\sigma$  is not  
→ suitable choice of  $g(x)$  can be used to minimize error

- ▶ Random number generators produce uniform pseudo-random numbers in  $[0, 1]$
- ▶ Assume we want points following the distribution  $g(x)$  with known primitive  $G(x)$  instead
- ▶ Probability of producing point in  $[x, x + dx]$  is  $g(x) dx$
- ▶ Can generate  $x$  according to

$$\int_a^x dx' g(x') = R \int_a^b dx' g(x')$$

where  $R$  is a uniform random number in  $[0, 1]$

$$x = G^{-1} \left[ G(a) + R(G(b) - G(a)) \right]$$

- ▶ Assume nuclear decay process described by  $g(x)$
- ▶ Nucleus can decay only if it has not decayed already  
Must account for survival probability  $\leftrightarrow$  Poisson distribution

$$\mathcal{G}(x) = g(x)\Delta(x, b) \quad \text{where} \quad \Delta(x, b) = \exp\left\{-\int_x^b dx' g(x')\right\}$$

- ▶ If  $G(x)$  is known, then we also know the integral of  $\mathcal{G}(x)$

$$\int_x^b dx' \mathcal{G}(x') = \int_x^b dx' \frac{d\Delta(x', b)}{dx'} = 1 - \Delta(x, b)$$

- ▶ Can generate events by requiring  $1 - \Delta(x, b) = 1 - R$

$$x = G^{-1}\left[G(b) + \log R\right]$$

- ▶ Veto algorithm  $\leftrightarrow$  Hit-or-miss method for Poisson distributions

- ▶ Generate event according to  $\mathcal{G}(x)$
- ▶ Accept with  $w(x) = f(x)/g(x)$
- ▶ If rejected, continue starting from  $x$

- ▶ Probability for immediate acceptance

$$\frac{f(x)}{g(x)} g(x) \exp \left\{ - \int_x^b dx' g(x') \right\}$$

- ▶ Probability for acceptance after one rejection

$$\frac{f(x)}{g(x)} g(x) \int_x^b dx_1 \exp \left\{ - \int_x^{x_1} dx' g(x') \right\} \left( 1 - \frac{f(x_1)}{g(x_1)} \right) g(x_1) \exp \left\{ - \int_{x_1}^b dx' g(x') \right\}$$

- ▶ For  $n$  intermediate rejections we obtain  $n$  nested integrals  $\int_x^b \int_{x_1}^b \dots \int_{x_{n-1}}^b$

- ▶ Disentangling yields  $1/n!$  and summing over all possible rejections gives

$$f(x) \exp \left\{ - \int_x^b dx' g(x') \right\} \sum_{n=0}^{\infty} \frac{1}{n!} \left[ \int_x^b dx' [g(x') - f(x')] \right]^n = f(x) \exp \left\{ - \int_x^b dx' f(x') \right\}$$

[Siegert,Schumann,SH] arXiv:0912.3501

- ▶ In MC@NLO generate emission according to

$$\Delta^{(S)}(t, t') = \exp \left\{ - \int_t^{t'} d\Phi_1 \frac{S(\Phi_B; t, z, \phi)}{B(\Phi_B)} \right\}$$

- ▶ “dipole-term-correct” PS

$$f(t) \rightarrow \int dz d\phi J(t, z, \phi) \frac{S(\Phi_B; t, z, \phi)}{B(\Phi_B)}$$

$$g(t) \rightarrow \int dz d\phi J(t, z, \phi) K(t, z, \phi)$$

- ▶  $f(t)/g(t)$  may be negative e.g. due to subleading color dipoles  
→ probabilistic interpretation not possible
- ▶ Split weight into MC and **analytic** part using auxiliary function  $h(t)$

$$\frac{f(t)}{h(t)} g(t) \exp \left\{ - \int_t^{t_1} d\bar{t} g(\bar{t}) \right\} \prod_{i=1}^n \left[ \int_{t_{i-1}}^{t_{i+1}} dt_i \left( 1 - \frac{f(t_i)}{h(t_i)} \right) g(t_i) \exp \left\{ - \int_{t_i}^{t_{i+1}} d\bar{t} g(\bar{t}) \right\} \right]$$

$$w(t, t_1, \dots, t_n) = \frac{h(t)}{g(t)} \prod_{i=1}^n \frac{h(t_i) g(t_i) - f(t_i)}{g(t_i) h(t_i) - f(t_i)}$$

- ▶  $h(t)$  can be chosen freely, as long as  $\text{sgn}(h) = \text{sgn}(f)$ ,  $|f| < |h|$



- ▶ Start with set of  $n$  partons at scale  $t'$ , which evolve collectively. Sudakov form factors factorize, schematically

$$\Delta(t, t') = \prod_{i=1}^n \Delta_i(t, t') \quad \Delta_i(t, t') = \prod_{j=q,g} \Delta_{i \rightarrow j}(t, t')$$

- ▶ Use veto algorithm to find new scale  $t$  where branching occurs
  - ▶ Generate  $t$  using overestimate  $\alpha_s^{\max} P_{ab}^{\max}(z)$
  - ▶ Determine “winner” parton  $i$  and select new flavor  $j$
  - ▶ Select splitting variable according to overestimate
  - ▶ Accept point with weight  $\alpha_s(k_T^2) P_{ab}(z) / \alpha_s^{\max} P_{ab}^{\max}(z)$
- ▶ Construct splitting kinematics and update color flow
- ▶ Continue until  $t < t_c$

- ▶ Leading-order calculation for observable  $O$

$$\langle O \rangle = \int d\Phi_B B(\Phi_B) O(\Phi_B)$$

- ▶ NLO calculation for same observable

$$\langle O \rangle = \int d\Phi_B \left\{ B(\Phi_B) + \tilde{V}(\Phi_B) \right\} O(\Phi_B) + \int d\Phi_R R(\Phi_R) O(\Phi_R)$$

- ▶ Parton-shower result until first emission

$$\langle O \rangle = \int d\Phi_B B(\Phi_B) \left[ \Delta^{(K)}(t_c) O(\Phi_B) + \int_{t_c} d\Phi_1 K(\Phi_1) \Delta^{(K)}(t(\Phi_1)) O(\Phi_R) \right]$$

$$\xrightarrow{\mathcal{O}(\alpha_s)} \int d\Phi_B B(\Phi_B) \left\{ 1 - \int_{t_c} d\Phi_1 K(\Phi_1) \right\} O(\Phi_B) + \int_{t_c} d\Phi_B d\Phi_1 B(\Phi_B) K(\Phi_1) O(\Phi_R)$$

Phase space:  $d\Phi_1 = dt dz d\phi J(t, z, \phi)$

Splitting functions:  $K(t, z) \rightarrow \alpha_s / (2\pi t) \sum P(z) \Theta(\mu_Q^2 - t)$

Sudakov factors:  $\Delta^{(K)}(t) = \exp \left\{ - \int_t d\Phi_1 K(\Phi_1) \right\}$

- ▶ Subtract  $\mathcal{O}(\alpha_s)$  PS terms from NLO result

$$\int d\Phi_B \left\{ B(\Phi_B) + \tilde{V}(\Phi_B) + B(\Phi_B) \int d\Phi_1 K(\Phi_1) \right\} \dots$$

$$+ \int d\Phi_R \left\{ R(\Phi_R) - B(\Phi_B) K(\Phi_1) \right\} \dots$$

- ▶ In DLL approximation both terms finite  $\rightarrow$  MC events in two categories, Standard and  $\mathbb{H}$ ard

$$\mathbb{S} \rightarrow \bar{B}^{(K)}(\Phi_B) = B(\Phi_B) + \tilde{V}(\Phi_B) + B(\Phi_B) \int d\Phi_1 K(\Phi_1)$$

$$\mathbb{H} \rightarrow H^{(K)} = R(\Phi_R) - B(\Phi_B) K(\Phi_1)$$

- ▶ Color & spin correlations  $\rightarrow$  **NLO subtraction** needed

$1/N_c$  corrections can be faded out in soft region by **smoothing function**

$$\bar{B}^{(K)}(\Phi_B) = B(\Phi_B) + \tilde{V}(\Phi_B) + I(\Phi_B) + \int d\Phi_1 \left[ S(\Phi_R) - B(\Phi_B) K(\Phi_1) \right] f(\Phi_1)$$

$$H^{(K)}(\Phi_R) = \left[ R(\Phi_R) - B(\Phi_B) K(\Phi_1) \right] f(\Phi_1)$$

## Method 1

[Frixione,Webber] hep-ph/0204244

- ▶  $f(\Phi_1) \rightarrow 0$  in soft-gluon limit
- ▶ Full NLO only in hard / collinear region  
Missing subleading color terms in soft domain
- ▶ Only affects unresolved gluons  $\rightarrow$  no need to correct

## Method 2

[Krauss,Schönherr,Siegert,SH] arXiv:1111.1220

- ▶ Replace  $B(\Phi_B)K(\Phi_1) \rightarrow S(\Phi_R)$ , i.e. include color & spin correlations
- ▶ May lead to non-probabilistic  $\Delta^{(S)}(t)$   
Requires modification of veto algorithm
- ▶ Exact cancellation of all divergences without additional smoothing  
Equivalent to one-step full color parton shower algorithm

[Frixione, Webber] hep-ph/0204244

- ▶ Add parton shower, described by generating functional  $\mathcal{F}_{MC}$

$$\langle O \rangle = \int d\Phi_B \bar{B}^{(K)}(\Phi_B) \mathcal{F}_{MC}^{(0)}(\mu_Q^2, O) + \int d\Phi_R H^{(K)}(\Phi_R) \mathcal{F}_{MC}^{(1)}(t(\Phi_R), O)$$

Probability conservation  $\leftrightarrow \mathcal{F}_{MC}(t, 1) = 1$

- ▶ Expansion of matched result until first emission

$$\langle O \rangle = \int d\Phi_B \bar{B}^{(K)}(\Phi_B) \left[ \Delta^{(K)}(t_c) O(\Phi_B) \leftrightarrow \text{Diagram 1} \right. \\ \left. + \int_{t_c} d\Phi_1 K(\Phi_1) \Delta^{(K)}(t(\Phi_1)) O(\Phi_r) \right] + \int d\Phi_R H^{(K)}(\Phi_{n+1}) O(\Phi_R)$$

- ▶ Parametrically  $\mathcal{O}(\alpha_s)$  correct
- ▶ Preserves logarithmic accuracy of PS

[Nason] hep-ph/0409146

- ▶ Aim of the method: Eliminate negative weights from MC@NLO
- ▶ Replace BK  $\rightarrow$  R  $\Rightarrow$  no  $\mathbb{H}$ -events  $\Rightarrow \bar{B}^{(R)}$  positive in physical region
- ▶ Expectation value of observable is

$$\langle O \rangle = \int d\Phi_B \bar{B}^{(R)}(\Phi_B) \left[ \Delta^{(R)}(t_c, s_{\text{had}}) O(\Phi_B) + \int_{t_c}^{s_{\text{had}}} d\Phi_1 \frac{R(\Phi_R)}{B(\Phi_B)} \Delta^{(R)}(t(\Phi_1), s_{\text{had}}) O(\Phi_R) \right]$$

- ▶  $\mu_Q^2$  has changed to hadronic centre-of-mass energy squared,  $s_{\text{had}}$ , as full phase space for real-emission correction, R, must be covered
- ▶ Absence of  $\mathbb{H}$ -events leads to enhancement of high- $p_T$  region by

$$K = \frac{\bar{B}}{B} = 1 + \mathcal{O}(\alpha_s)$$

Formally beyond NLO, but sizeable corrections in practice

[Alioli, Nason, Oleari, Re] arXiv:0812.0578

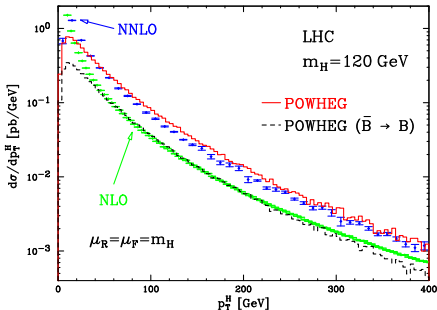
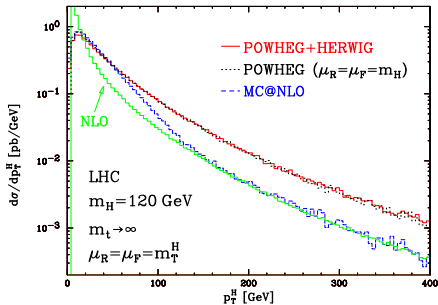

- ▶ Large enhancement at high  $p_{T,h}$
- ▶ Can be traced back to large NLO correction
- ▶ Fortunately, NNLO correction is also large  $\rightarrow \sim$  agreement

- ▶ To avoid problems in high- $p_T$  region, split real-emission ME into singular and finite parts as  $R = R^s + R^f$
- ▶ Treat singular piece in  $\mathbb{S}$ -events and finite piece in  $\mathbb{H}$ -events  
Similar to MC@NLO with redefined PS evolution kernels
- ▶ Differential event rate up to first emission

$$\langle O \rangle = \int d\Phi_B \bar{B}^{(R^s)}(\Phi_B) \left[ \Delta^{(R^s)}(t_c, s_{\text{had}}) O(\Phi_B) \right. \\ \left. + \int_{t_c}^{s_{\text{had}}} d\Phi_1 \frac{R^s(\Phi_R)}{B(\Phi_B)} \Delta^{(R^s)}(t(\Phi_1), s_{\text{had}}) O(\Phi_R) \right] + \int d\Phi_R R_n^f(\Phi_R)$$



[Alioli,Nason,Oleari,Re] arXiv:0812.0578

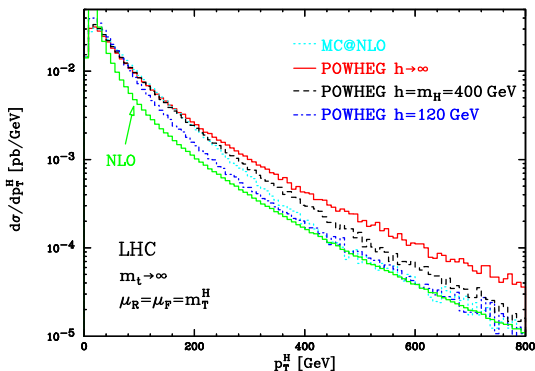

- Singular real-emission part here defined as

$$R^s = R \frac{h^2}{p_T^2 + h^2}$$

- Can “tune” NNLO contribution by varying free parameter  $h$

- ▶ Usually want to match hardest emission to matrix elements
- ▶ Thus need to identify hardness with evolution parameter
- ▶ What if evolution parameter of parton shower differs?

[Nason] hep-ph/0409146

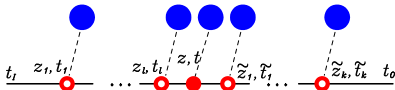

- ▶ Must implement additional emissions to account for missing Sudakov form factor “above” predefined branching
- ▶ Must also veto on emissions harder than matched branching
- ▶ Truncated, vetoed parton shower

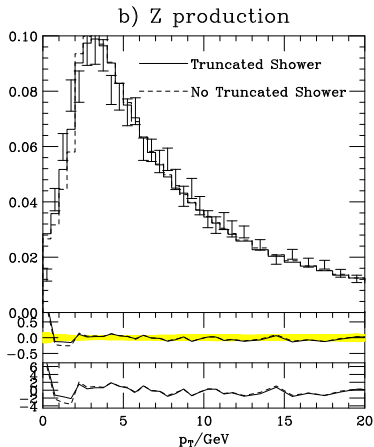
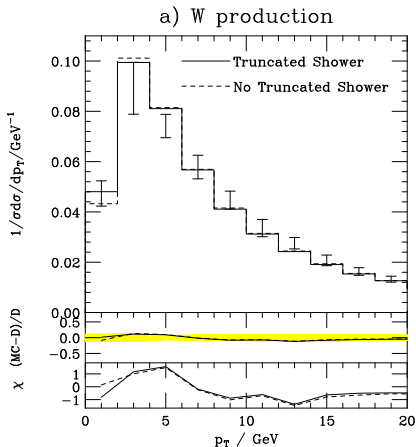

- ▶ Small effect, but also insensitive observable
- ▶ In general effects not small, see next lecture

[Catani, Krauss, Kuhn, Webber] hep-ph/0109231

[Krauss] hep-ph/0205283

- ▶ Select ME according to  $\sigma(> Q_{\text{cut}})$
- ▶ Construct PS history
- ▶ Weight each vertex with  $\alpha_s(q^2)/\alpha_s(\mu_R^2)$
- ▶ Weight parton of type  $i$  from  $Q_j$  to  $Q_k$  by  $\Delta_i(Q_{\text{cut}}, Q_j)/\Delta_i(Q_{\text{cut}}, Q_k)$   
 → Sudakov suppression to NLL accuracy
- ▶ Veto parton shower if emission has  $Q > Q_{\text{cut}}$

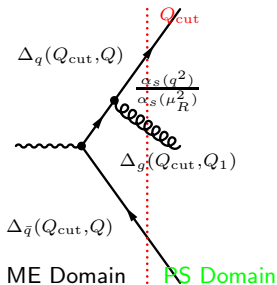

- ▶ Convenient choices made
  - ▶ Clustering with Durham  $k_T$ -algorithm
  - ▶ Analytic Sudakov form factors
  - ▶ No truncated showers  
Instead redefined starting scales
- ▶ Correct to NLL, but exact correspondence with PS is lost
- ▶ Problems due to modified colour flow and kinematics

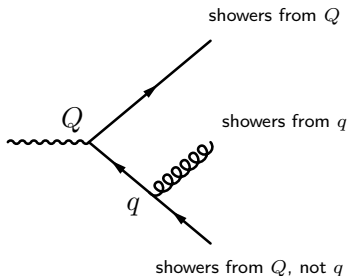

[Mangano,Moretti,Pittau] hep-ph/0108069

[Mangano,Moretti,Piccinini,Treccani] hep-ph/0611129

- ▶ Define parton-level jets using cone algorithm

$$R_{ij}^2 = (\eta_i - \eta_j)^2 + (\phi_i - \phi_j)^2$$

$$E_{T,i} > E_{T,\min}, \quad R_{ij} > R_{\min}$$

- ▶ Generate parton showers from  $n$ -jet events  
No Sudakov suppression at this point
- ▶ Form new jets on showered final state
- ▶ Reject if number of jets increased  
or jets not “matched” to partons in  $R_{ij}$
- ▶ Sudakov suppression achieved by jet matching

[Hamilton, Richardson, Tully] arXiv:0905.3072

truncated shower on

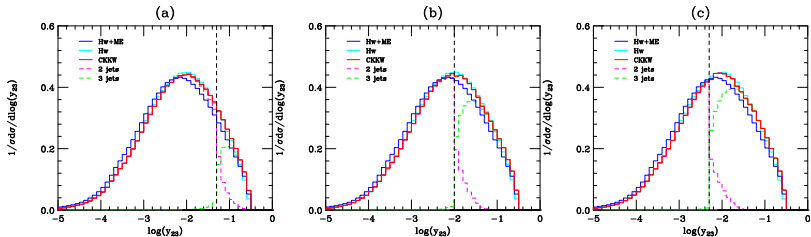

truncated shower off

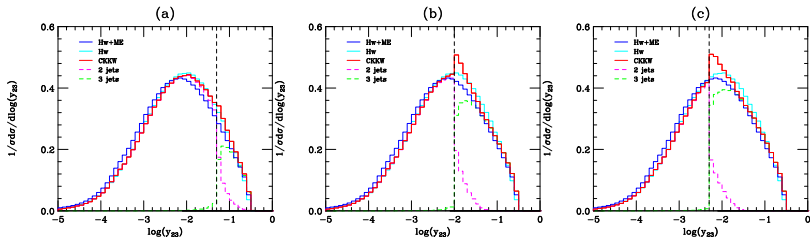

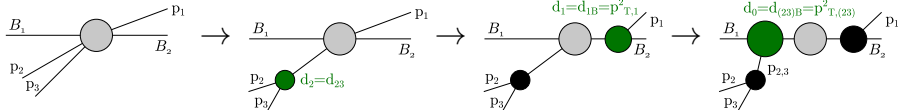
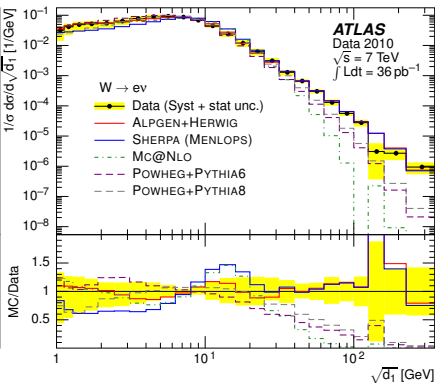
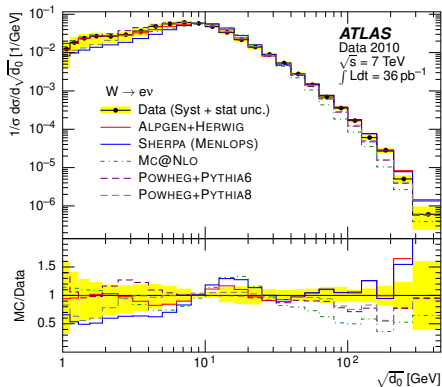



[ATLAS] 1302.1415

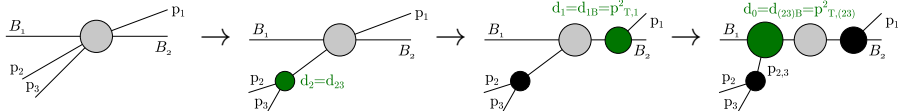
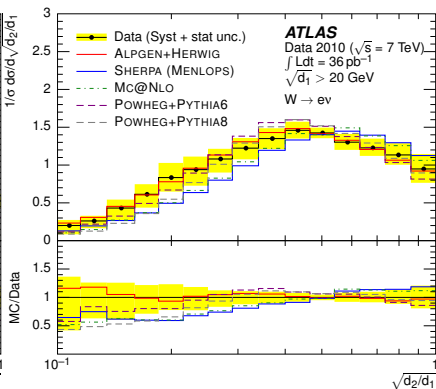
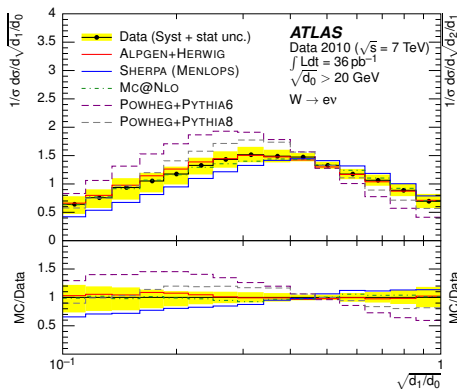

[ATLAS] arXiv:1109.1470

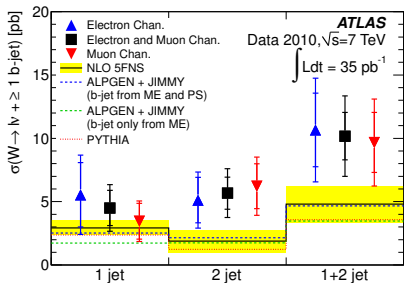

## Z+b cross section

[ATLAS] arXiv:1109.1403

Experiment	$3.55^{+0.82}_{-0.74}(\text{stat})^{+0.73}_{-0.55}(\text{syst}) \pm 0.12(\text{lumi}) \text{ pb}$
MCFM	$3.88 \pm 0.58 \text{ pb}$
ALPGEN	$2.23 \pm 0.01 \text{ (stat only) pb}$
SHERPA	$3.29 \pm 0.04 \text{ (stat only) pb}$

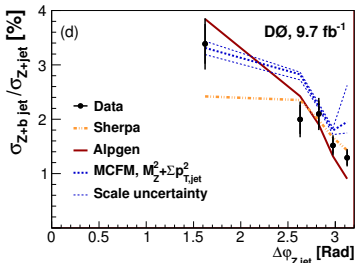
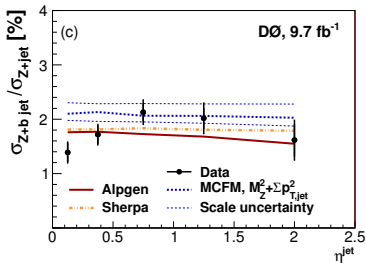
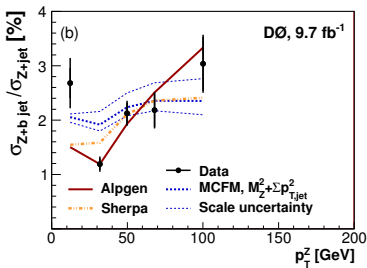
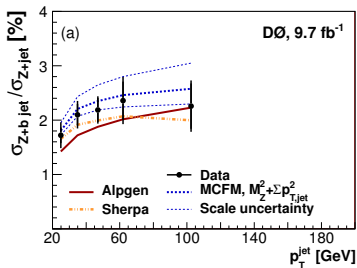

## DØ analysis of $\gamma$ +bjet production

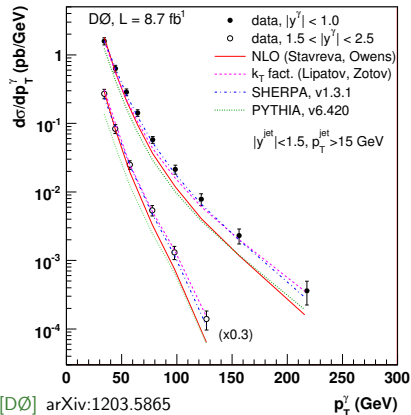

[DØ] arXiv:1203.5865

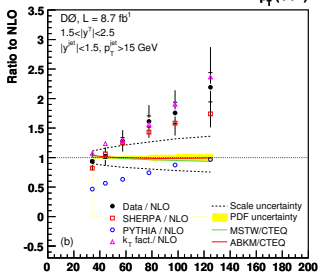
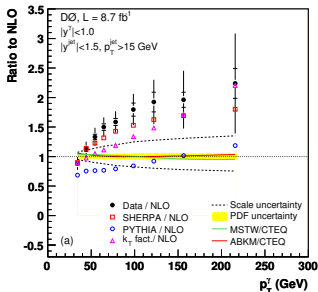

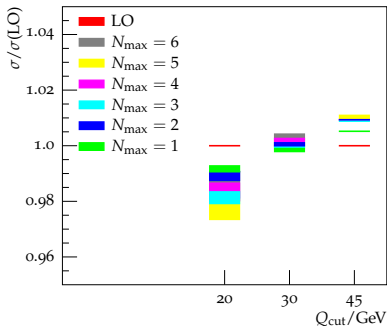

- ▶ MEPS effectively replaces splitting kernels of the parton shower with ratios of LO matrix elements for the emission terms
- ▶ We have not corrected the Sudakov form factors, hence there is a mismatch between emission- and no-emission probability
- ▶ The inclusive cross section changes, but corrections are small

- Unitarity condition of PS:

$$1 = \Delta^{(K)}(t_c) + \int_{t_c} d\Phi_1 K(\Phi_1) \Delta^{(K)}(t)$$

- CKKW-like merging violates PS unitarity as **ME ratio** replaces **splitting kernels** in emission terms, but not in Sudakovs

$$K(\Phi_1) \rightarrow \frac{R(\Phi_1, \Phi_B)}{B(\Phi_B)}$$

- Mismatch removed by **explicit subtraction**

$$1 = \underbrace{\left\{ \Delta^{(K)}(t_c) + \int_{t_c} d\Phi_1 \left[ K(\Phi_1) - \frac{R(\Phi_1, \Phi_B)}{B(\Phi_B)} \right] \Theta(Q - Q_{\text{cut}}) \Delta^{(K)}(t) \right\}}_{\text{unresolved emission / virtual correction}} + \underbrace{\int_{t_c} d\Phi_1 \left[ K(\Phi_1) \Theta(Q_{\text{cut}} - Q) + \frac{R(\Phi_1, \Phi_B)}{B(\Phi_B)} \Theta(Q - Q_{\text{cut}}) \right] \Delta^{(K)}(t)}_{\text{resolved emission}}$$

[Lönnblad, Prestel] JHEP02(2013)094

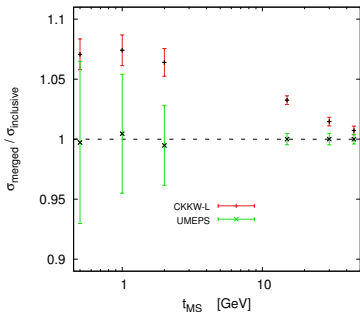

Simulation often too focused on resonant contributions

Need be inclusive to describe DIS, low-mass Drell-Yan or photon / diphoton production

