





Photon Detector Calibration Monitoring System

Zelimir Djurcic, Patrick De Lurgio, Gary Drake,
Michael Oberling

Argonne National Laboratory
zdjurcic@anl.gov, drake@anl.gov

Introduction

- The Following Review Questions will be addressed:
 1. Does the Photon Detector System design enable validation and refinement of the DUNE photon detector requirements?
 2. Are Photon Detector System risks captured and is there a plan for managing and mitigating these risks?
 3. Does the design lead to a reasonable production schedule, including QA, transport, installation and commissioning? 
 4. Does the documentation of the Photon Detector System technical design provide sufficiently comprehensive analysis and justification for the Photon Detector System design adopted? 
 5. Is the Photon Detector system scope well defined and complete? Are all Photon Detector System interfaces to other detector components: APA, cryostat and DAQ systems documented, clearly identified and complete? Do the electronics feedthrough port and TPC integrated 3D models adequately represent the mechanical, electrical and electronic interfaces to the Photon Detector System? Is the cabling, power and calibration well defined and understood? Is the grounding and shielding understood and adequate? 
 6. Are the Photon Detector System 3D model(s), top level assembly drawings, detail/part drawings and material and process specifications sufficiently complete to demonstrate that the design can be constructed and installed? 
 7. Are operation conditions listed, understood and comprehensive? Is there an adequate calibration plan? 
 8. Are the Photon Detector System engineering analyses sufficiently comprehensive for safe handling, installation and operation at the CERN Neutrino Platform? Is the installation plan sufficiently well developed? Is the design for installation tooling adequate for installing the photon system?
 9. Have applicable lessons-learned from previous LArTPC devices been documented and implemented into the QA plan? Are the Photon Detector System quality control test plans and inspection regimes sufficiently comprehensive to assure efficient commissioning and adequate operational performance of the NP04 experiment?

Photon Detector UV-light Calibration

- The photon detector calibration is a part of a larger calibration plan that covers all aspects of an LAr detector calibration to calibrate both TPC and photon detection system
 - example: muon-hodoscope system at protoDUNE, laser at DUNE, etc.
- Here we describe a light-flasher based calibration system designed to monitor the performance of the photon detection system.
 - The system will consist of a set of LEDs as light sources in VUV wavelength ranged, coupled to quartz fibers transmitting light from outside the detector volume to desired locations of CPA to emit light to APA.
- It will be used to:
 - a) Verify that the channels are functioning properly.
 - b) Calibrate SiPM gains and monitor the relative detector efficiency over time.
 - c) Monitor relative timing performance of the system.

Photon Detector UV-light Calibration

- The external light-flasher calibration system is designed under following assumptions:
 - simple to implement (no active components within PD/APA).
 - uniformly illuminates APA surface with the light diffused from CPA locations
 - has a potential to be adapted for deployment in a large Far Detector in the future
- In terms of technical requirements the system needs to:
 - uniformly illuminate the APA area of the detector
 - provide light levels down to a single P.E. at individual photon-detector channels
 - provide variable pulse width to test the time resolution of the photon- detector response

UV Light Calibration System

- UV light calibration system design:
 - transports light from 275 nm UV LEDs through quartz fibers to the TPC volume
 - diffuse light to the photon detection system light collection elements
 - use UV light (will be wavelength shifted) to mimic physics of LAr scintillation light
 - observe SiPM response to shifted light.

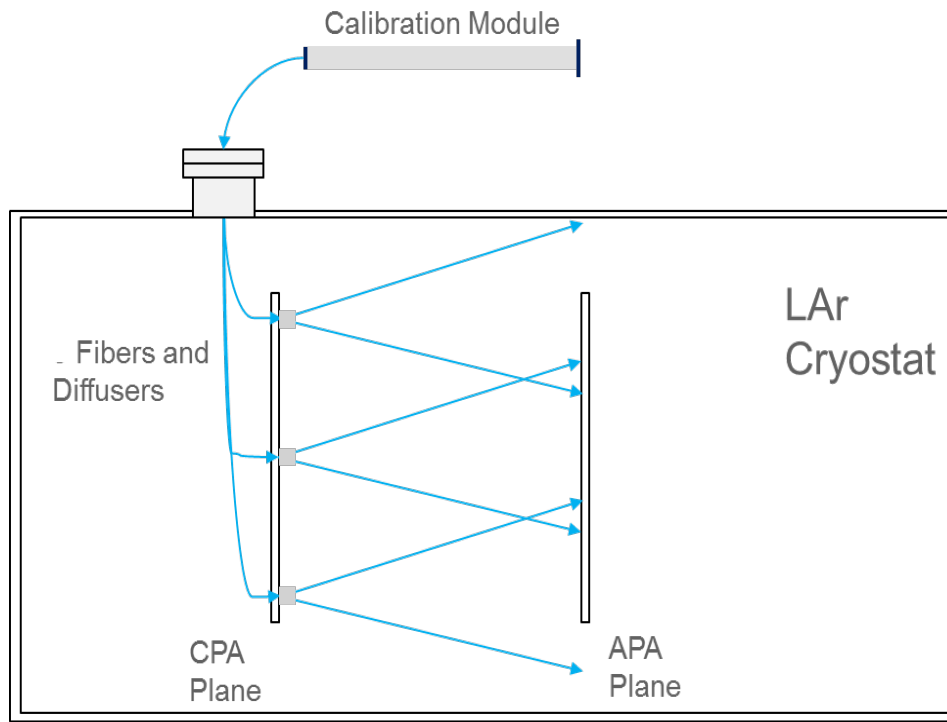

- Outer Components:
 - Optical quartz fiber
 - Calibration Module with 275nm LEDs
- Inner Components:
 - Light diffusers at CPA plane
 - Optical quartz fiber
 - Flange with fiber feed-through

Current Status: 35ton DUNE Prototype

- The system has been designed, tested, installed, integrated, and operated with the 35-ton DUNE prototype detector

Photon Detector Calibration System Components

- Calibration module sources 5 UV LEDs (275nm)
- 275 nm light excites only wavelength shifter
- Quartz fibers deliver light to 5 diffusers mounted on CPA plane
- Diffusers distribute light onto photon detectors at APA plane
- One central Diffuser for Timing
- Four corner Diffusers for Uniformity/Gain
- Pulse widths from 5ns to 820ns
- Up to 25mW instantaneous optical power

Optical Simulation

- TracePro used for optical system design, simulation, and optimization

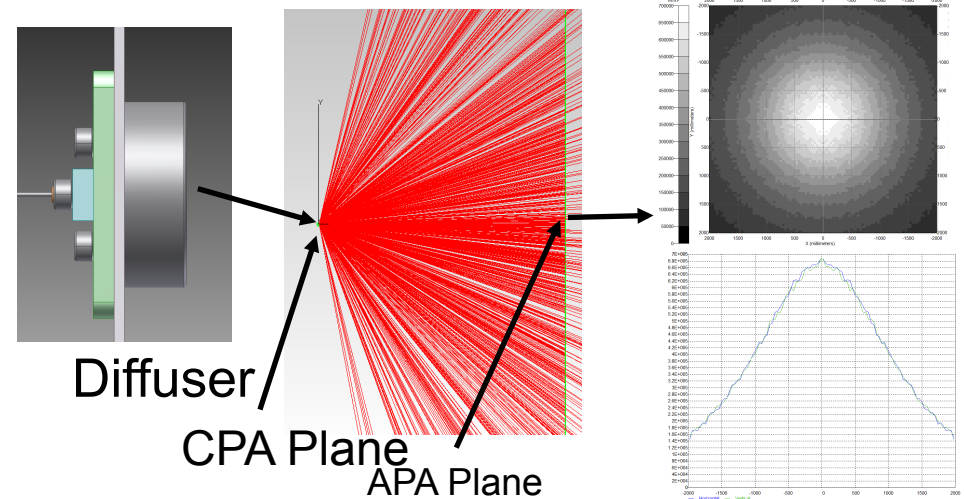
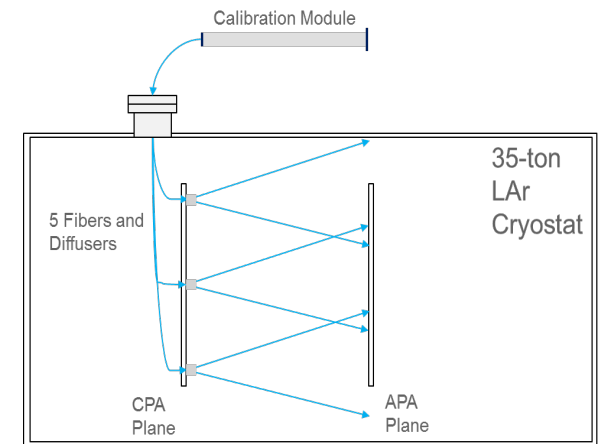

Optical Simulation of Single Diffuser at APA distance

Diffuser Implementation for 35-ton detector

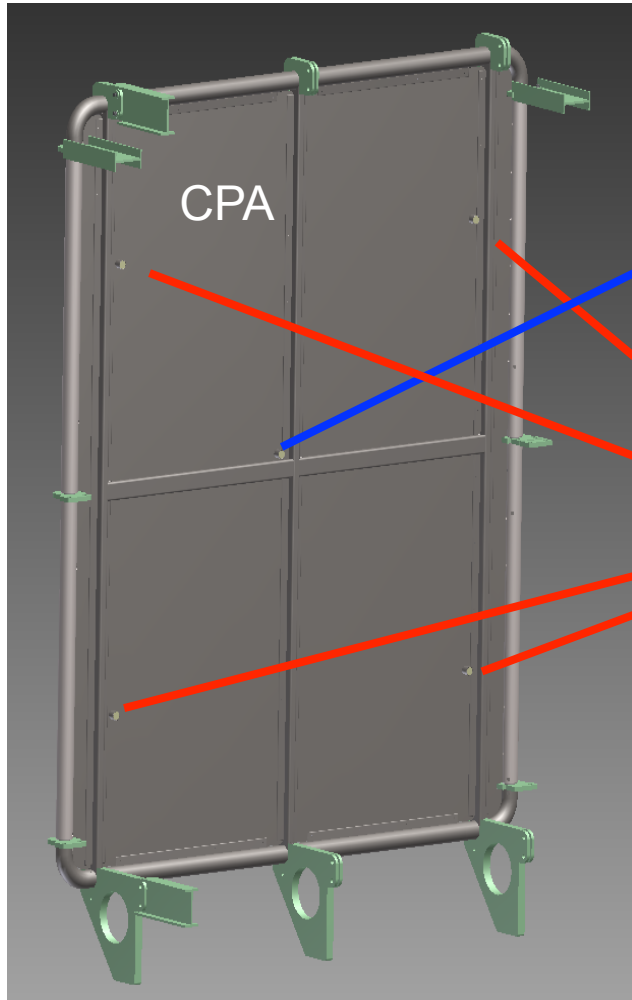
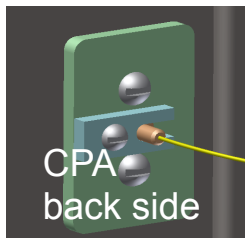
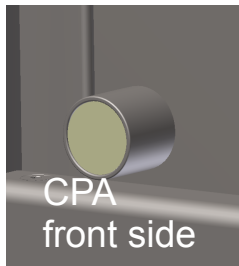

Central location timing calibration

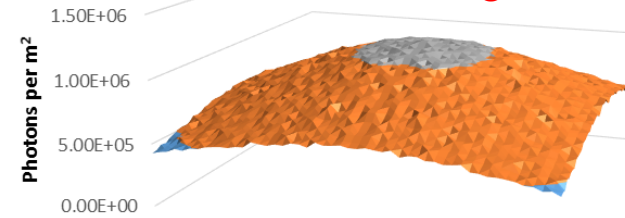

Photon distribution on 2x2 m² APA Plane

Max	~5E+06 photons/m ²
Min	~2.5E+06 photons/m ²
Max/Min	~2
% STDEV	19%

4 corner locations gain calibration

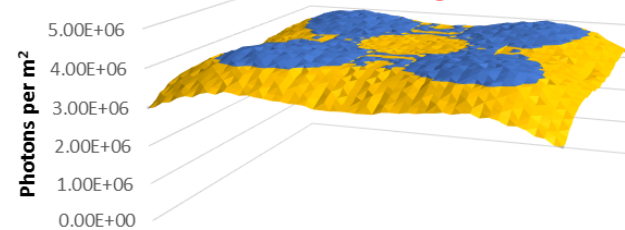

Photon distribution on 2x2 m² APA Plane

Max	~4.3 E+06 photons/m ²
Min	3.0 E+06 photons/m ²
Max/Min	1.44
% STDEV	6.2%

DUNE Calibration Module

- Utilizes the SSP mainboard as a controller
Ethernet communication, NOvA timing control, internal/external triggering, etc.

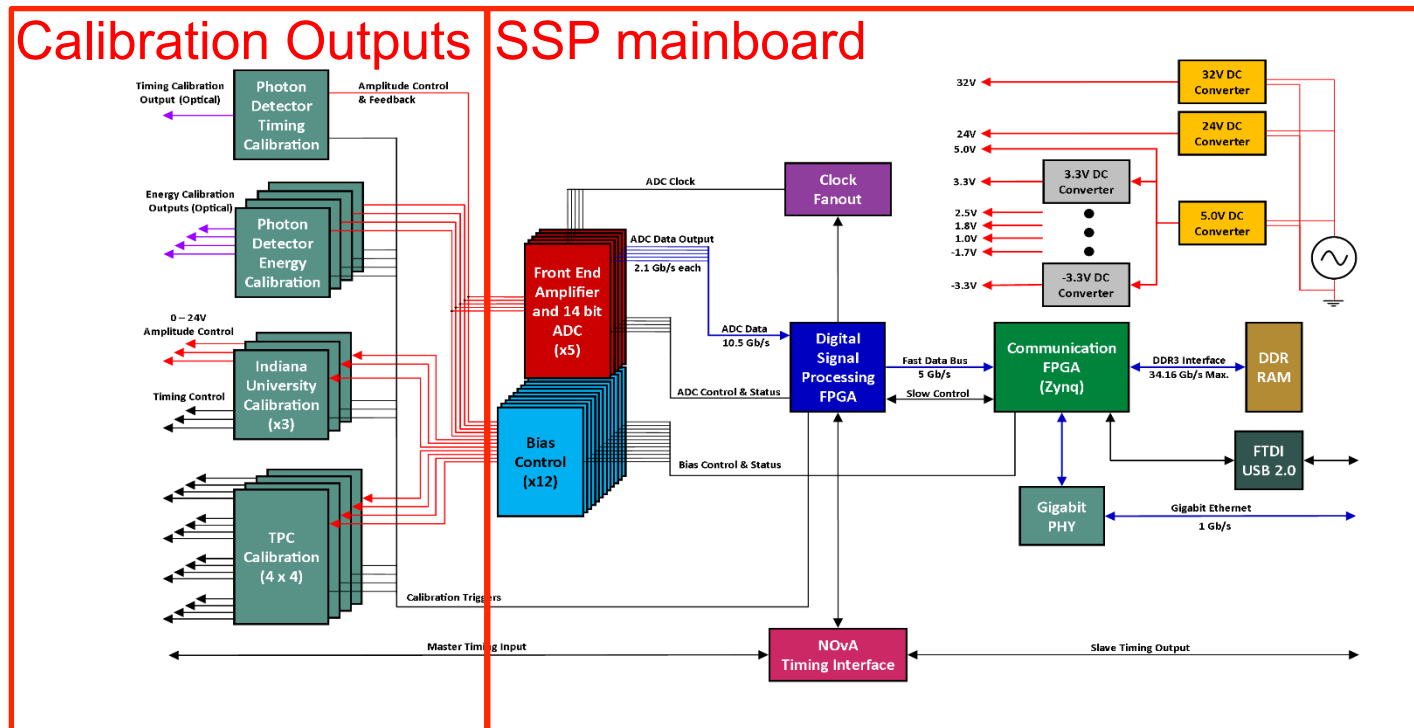

Calibration Backpanel



DUNE Calibration Module

Calibration Board

SSP mainboard

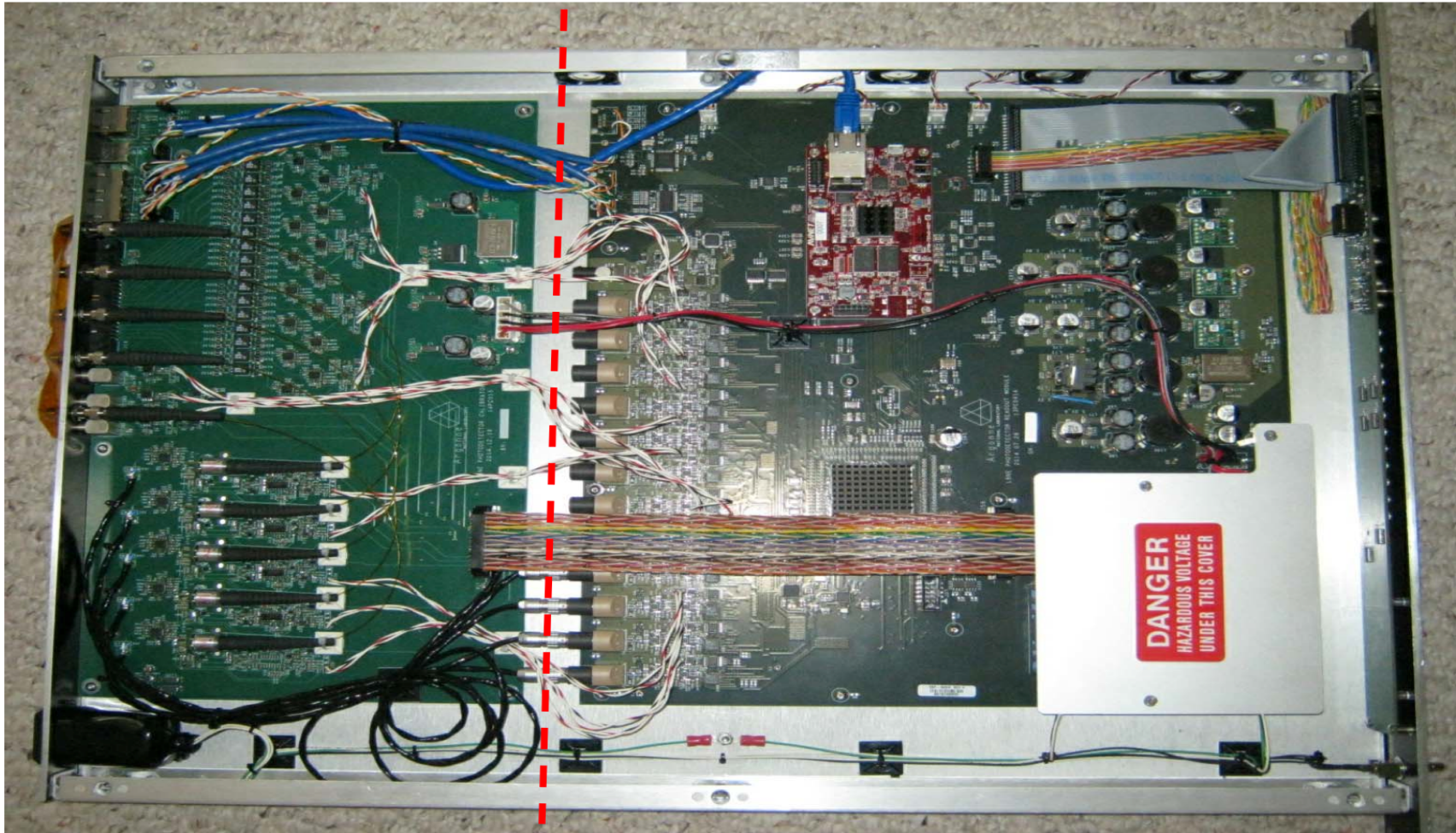

DUNE Calibration Module

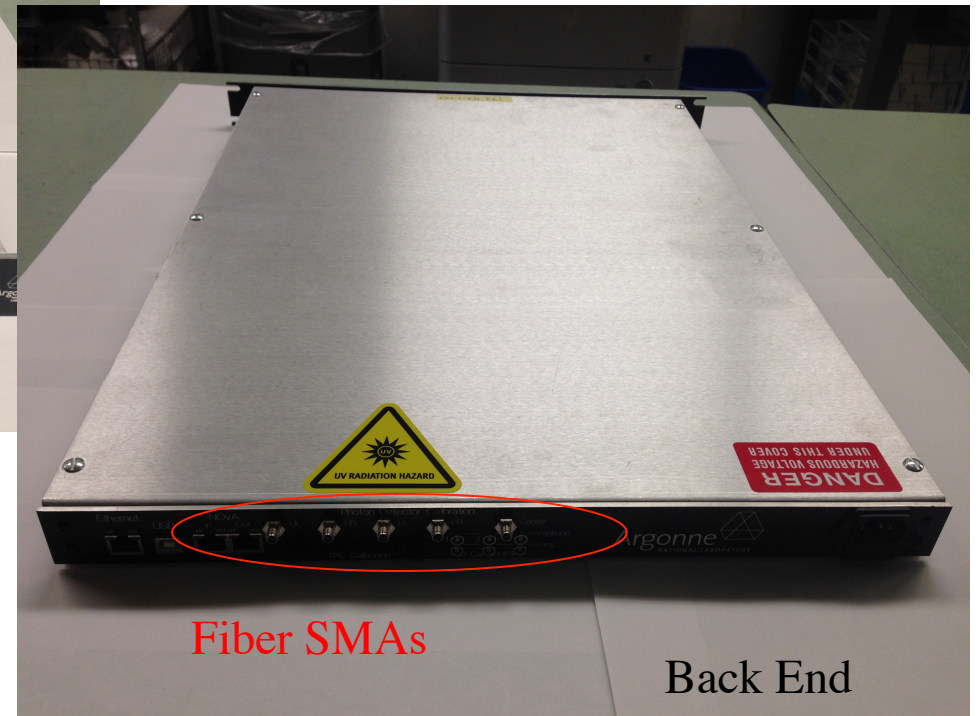
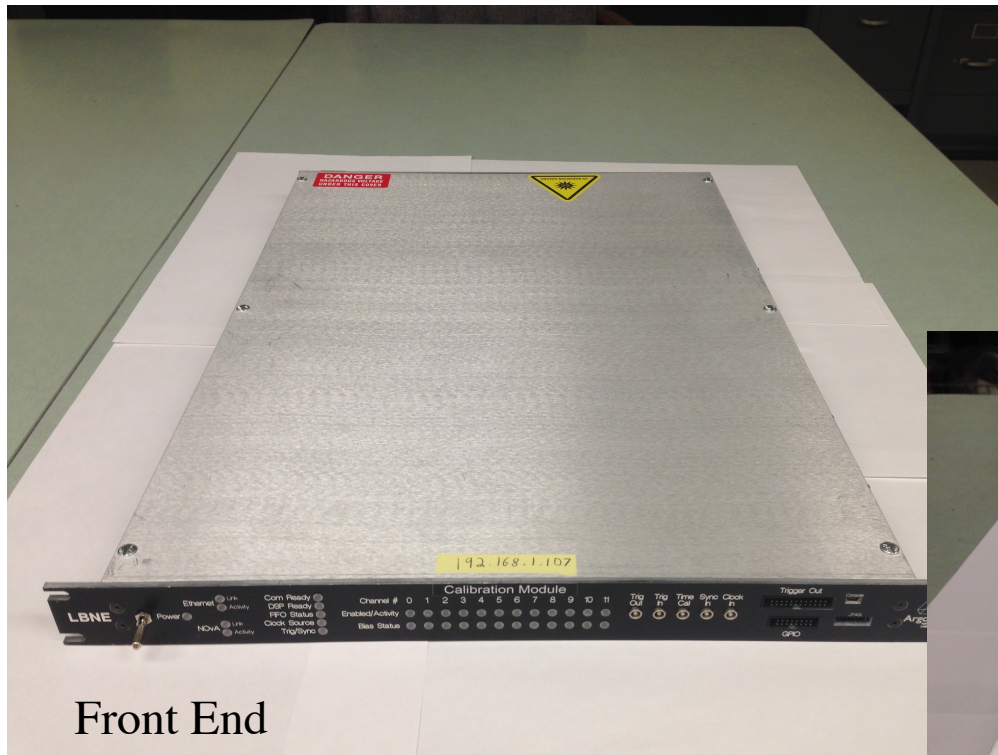

Components of the PD UV Calibration System

- Components installed with 35t DUNE prototype

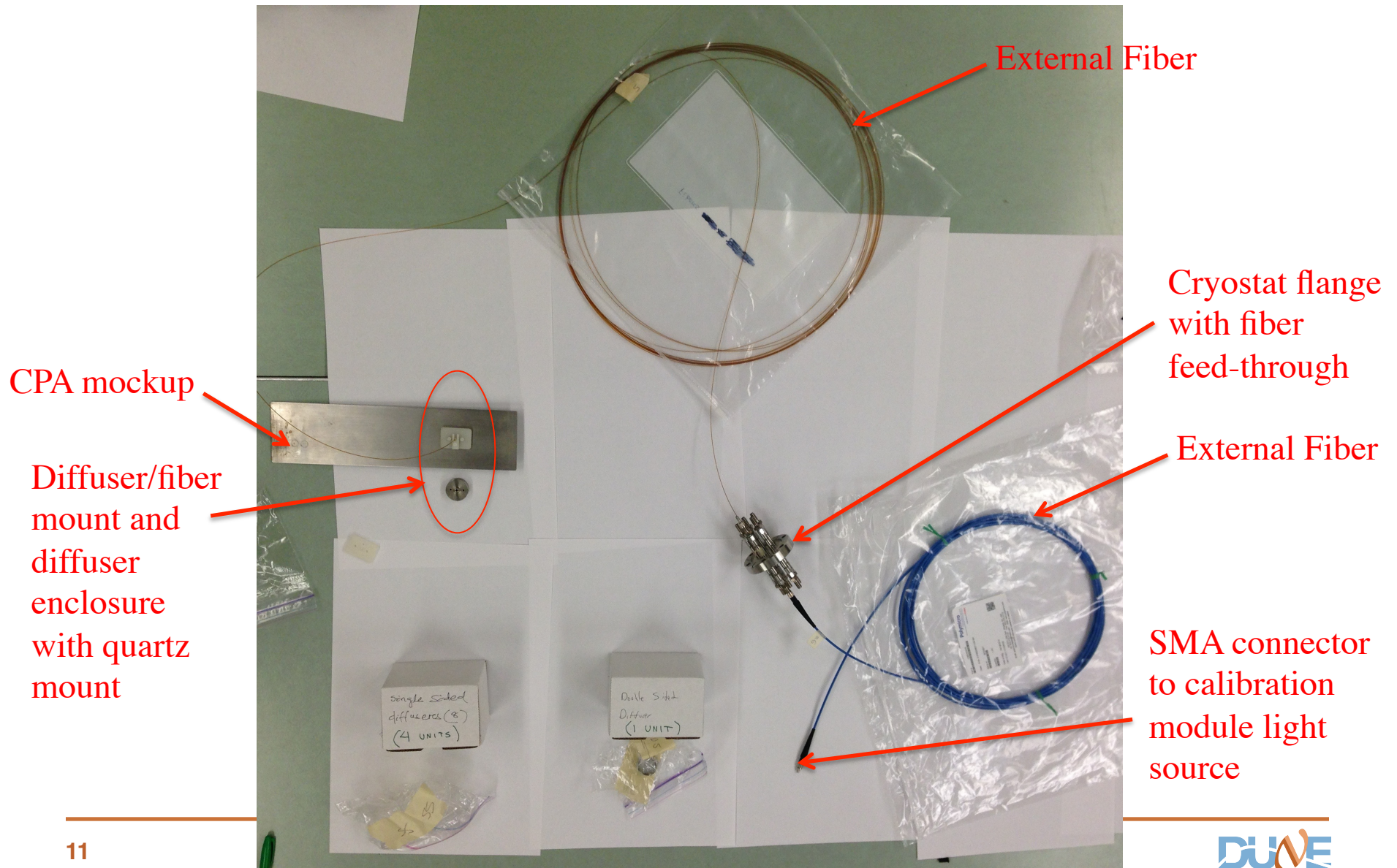

Components of the PD UV Calibration System

- Components installed with 35t DUNE prototype

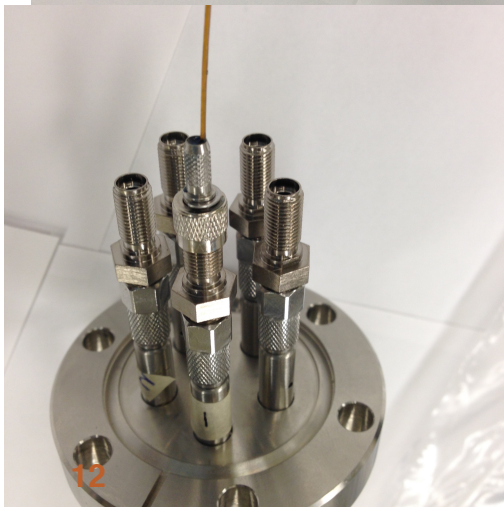
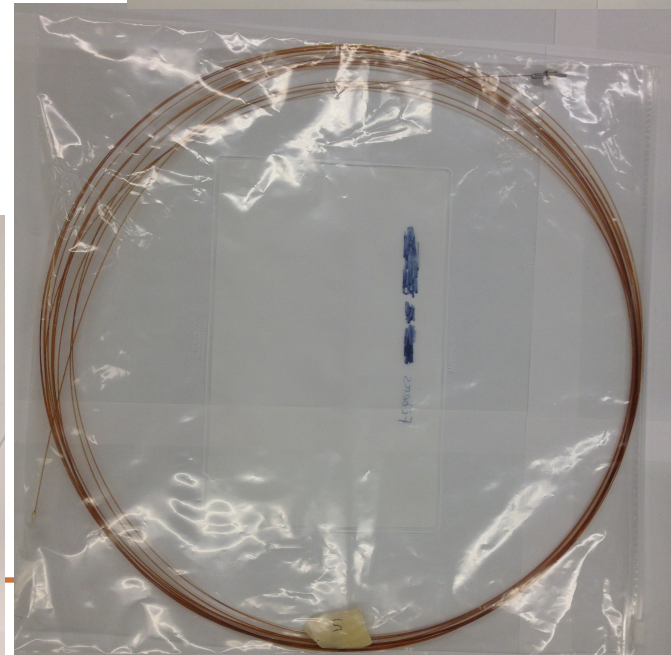
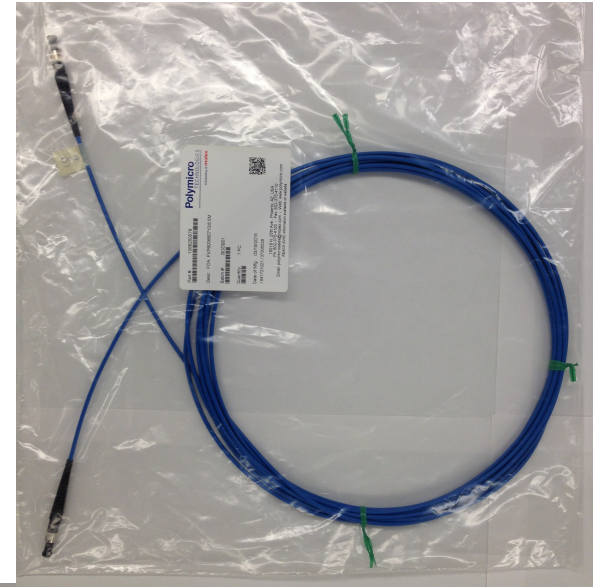
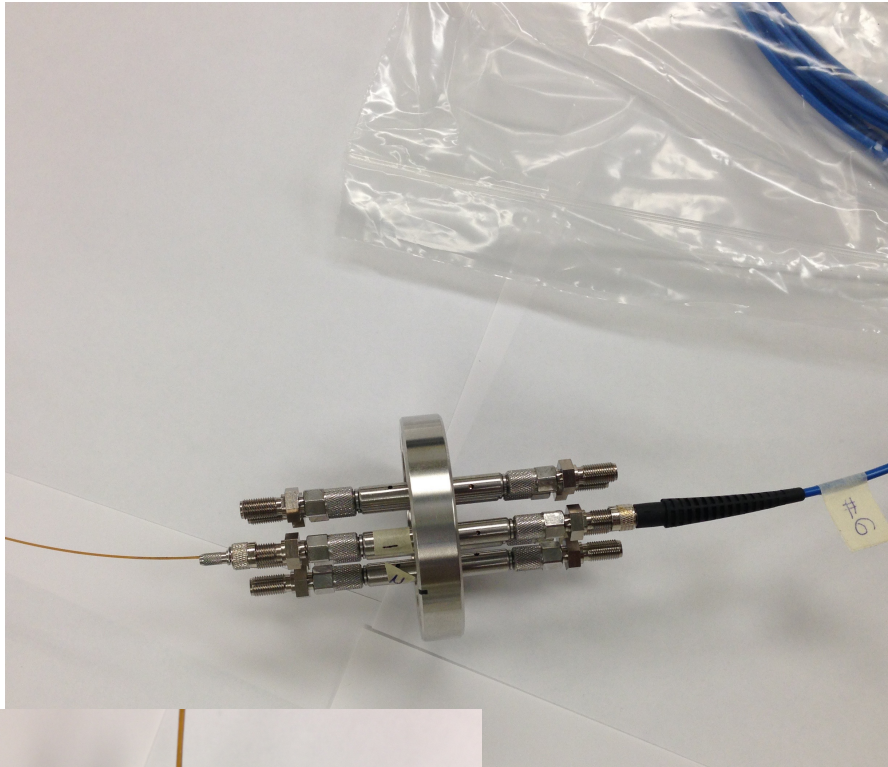

Components of the PD UV Calibration System

- Components installed with 35t DUNE prototype

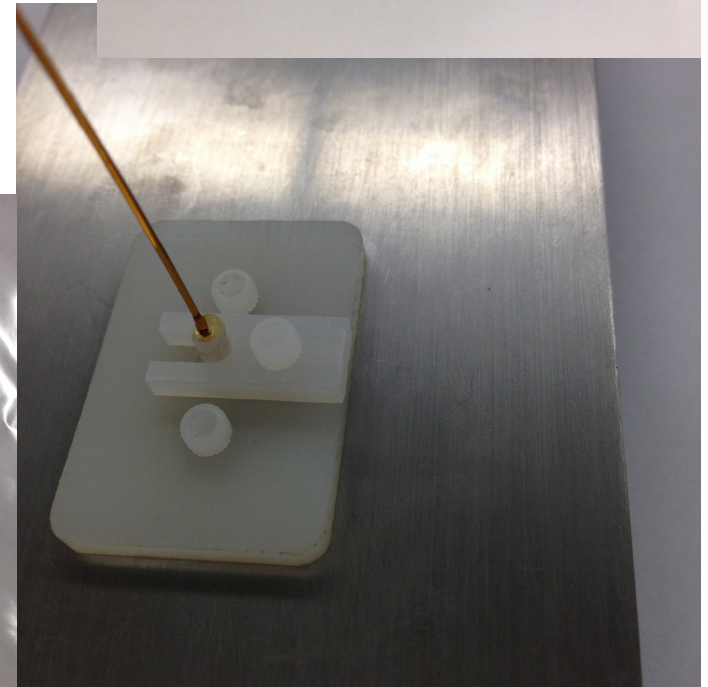
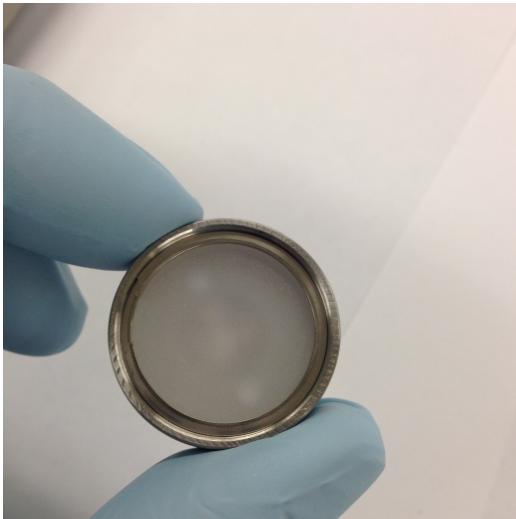
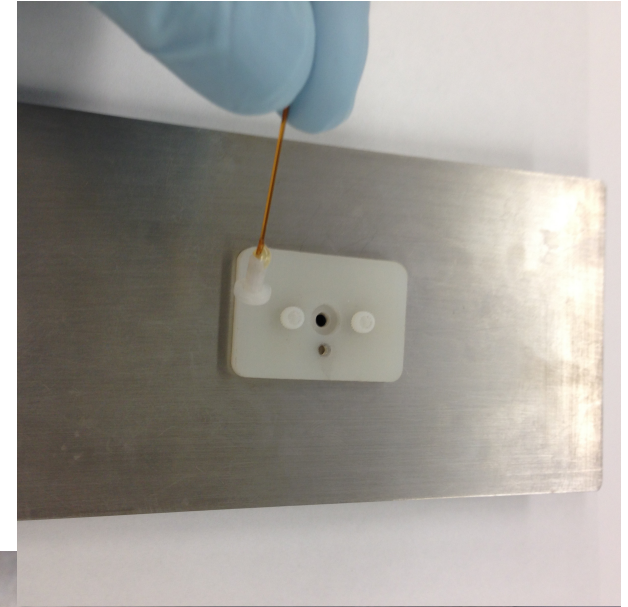
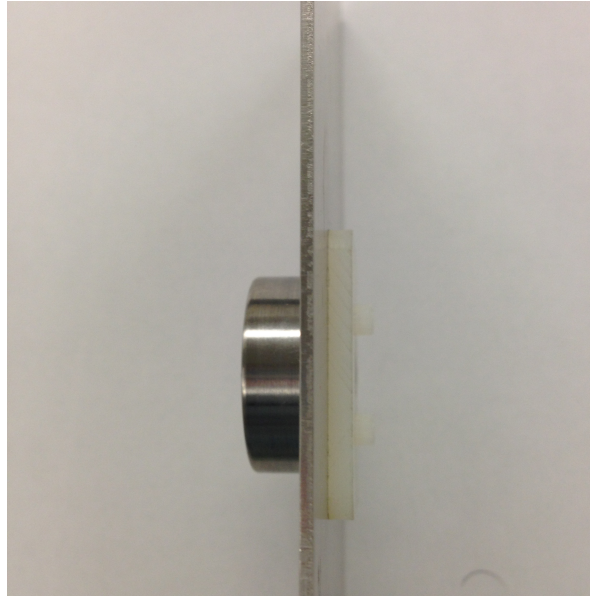
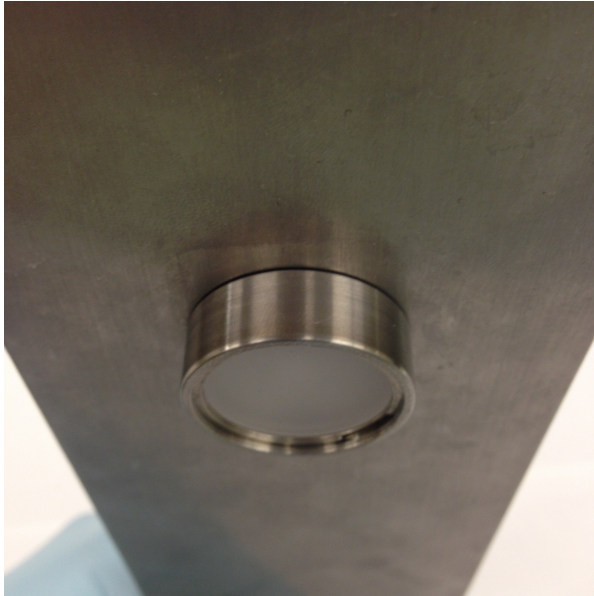

Components of the PD UV Calibration System

- Components installed with 35t DUNE prototype

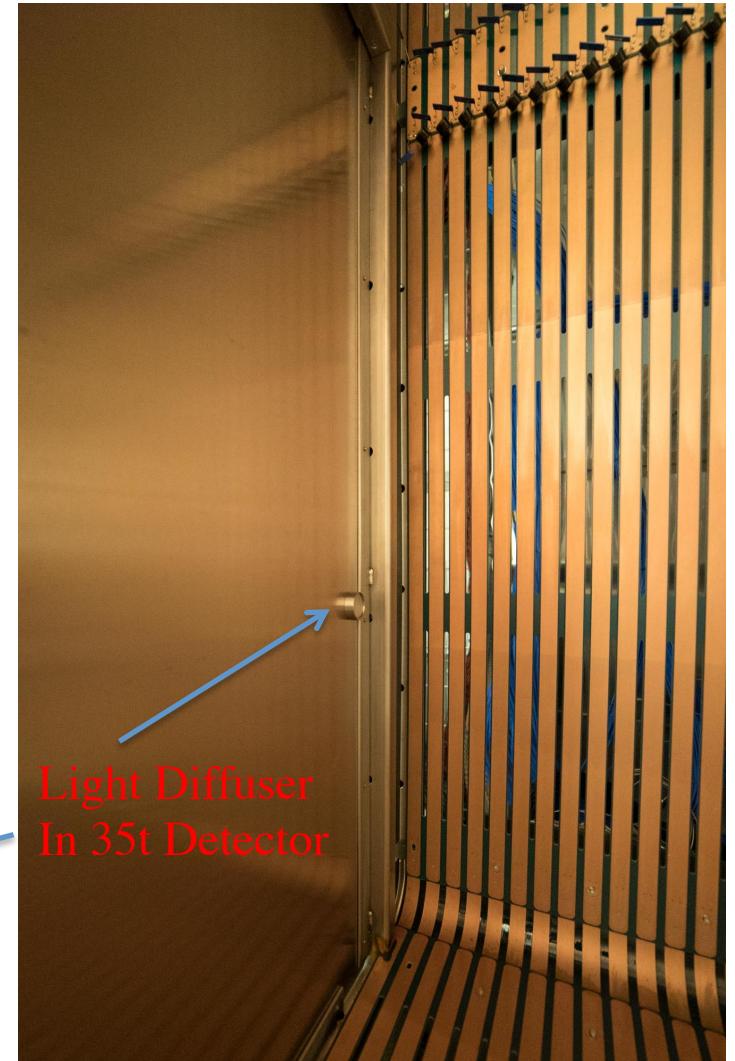
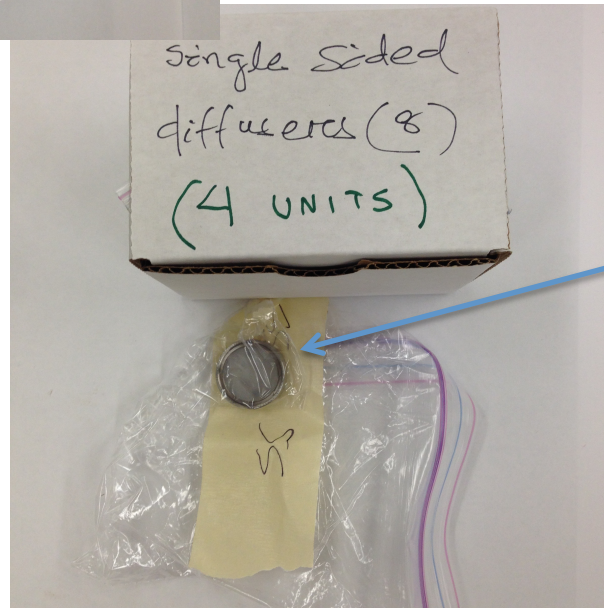
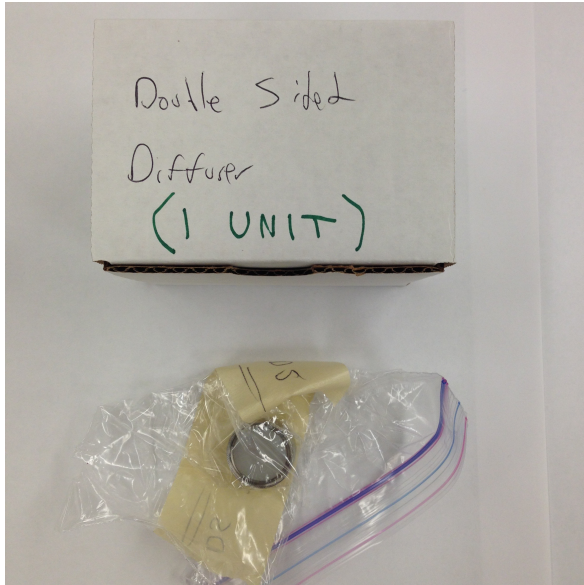

35t Status

- PD UV calibration system has been operational
- Collected calibration data demonstrated functionality of the calibration system and examined the functionality of the photon-detector channels
 - observe normal channels (i.e. standard response)
 - discover noise channels
 - discover malfunctioning PD channels

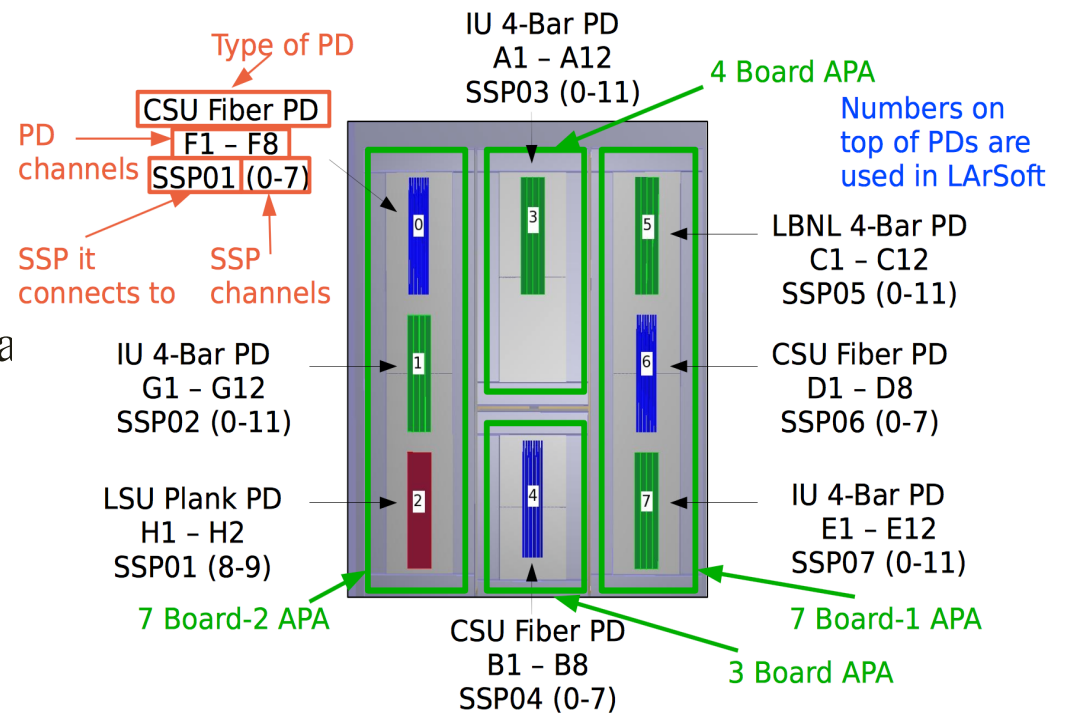

35-ton Experience

- PD UV calibration system has been operational
- Collected calibration data demonstrated functionality of the calibration system and examined the functionality of the photon-detector channels
 - observe normal channels (i.e. standard response)
 - discover noise channels
 - discover malfunctioning PD channels
- Example of PD Calibration Runs on next few slides
 - central diffuser only
 - pulse width = 50, 10, 3.33 ns
 - pulse amplitude 30 V
 - pulse frequency 143 Hz
 - SSP self-triggering mode
 - SSP 1, 2, 3, 5, 6, 7 data collected.
- In addition we have used the calibration module as a trigger in TPC noise tests.
- We have collected data with all five UV-light diffusers with different pulse lengths and pulse heights.

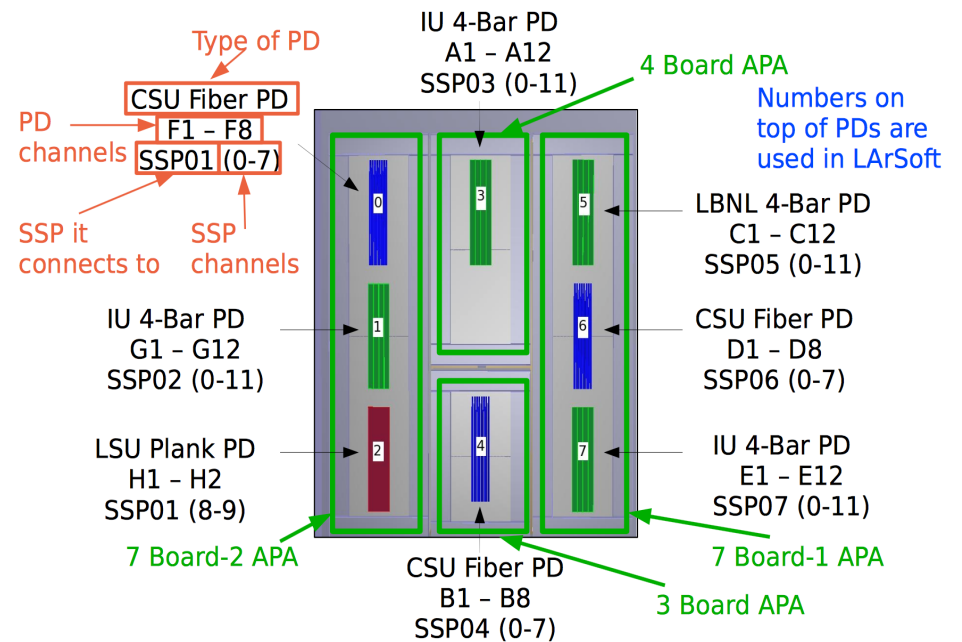

PD Channels with Standard Response

Channels: 0, 2, 3, 4, 5, 6, 7, 12, 12, 13, 14, 15, 17, 18, 19, 20, 21, 22, 23, 24, 25, 37, 38, 39, 40, 41, 42, 43, 44, 45, 46, 62, 63, 64, 66, 67, 70, 71, 72, 73, 75, 76, 77, 78, 79, 84, 85, 86, 88, 89, 90, 91, 94, 95.

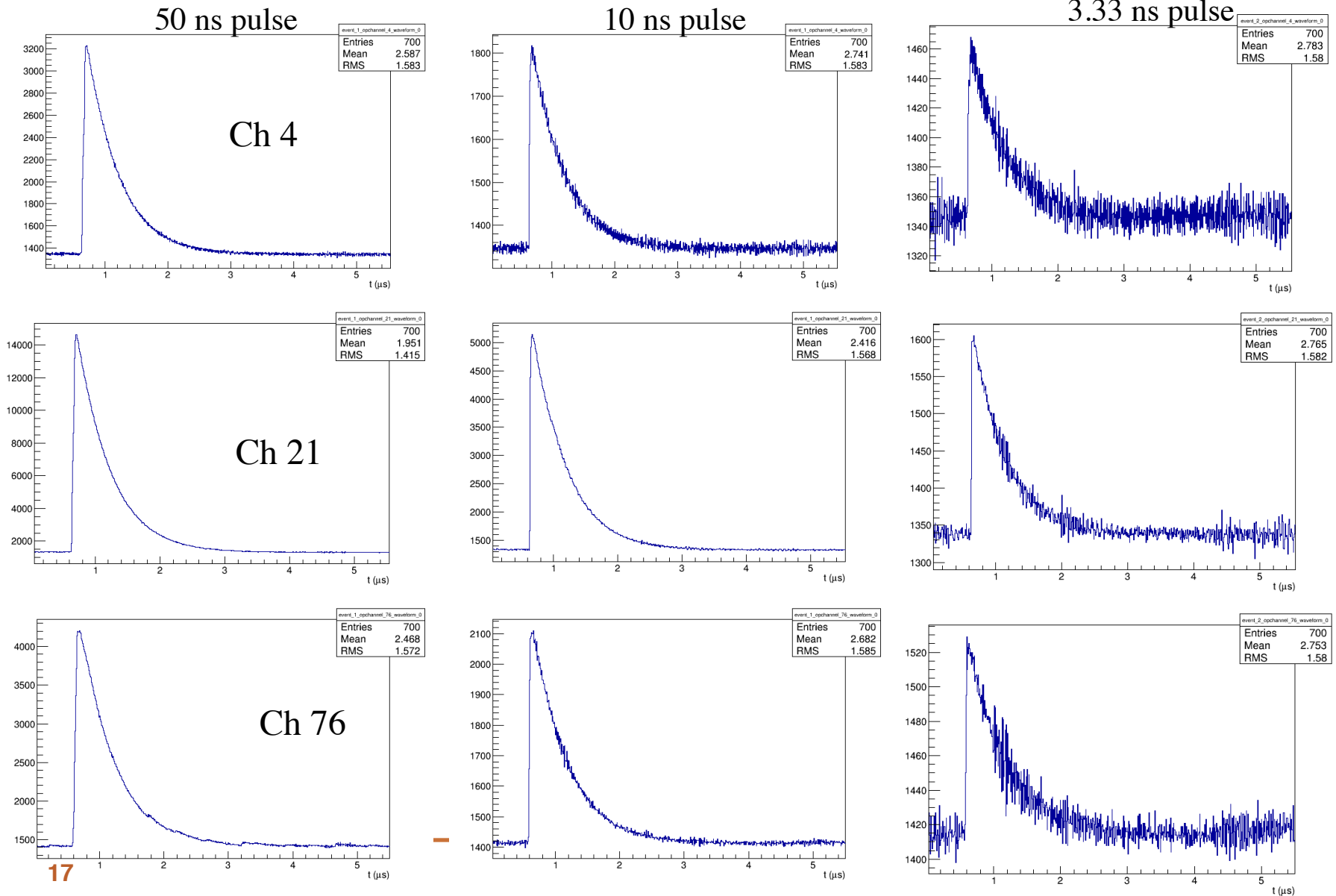

Malfunctioning and non-standard PD Channels

- Malfunctioning Channels: 1, 36, 47, 87

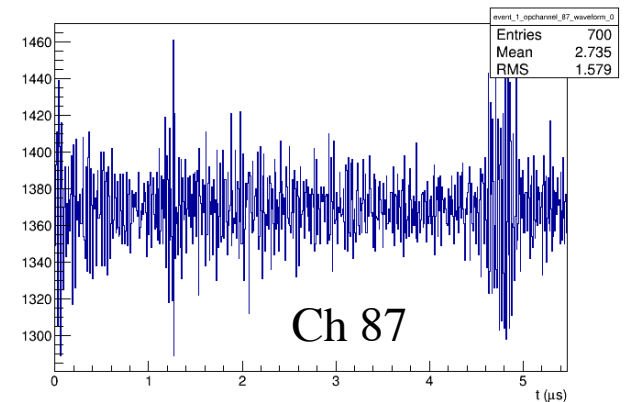
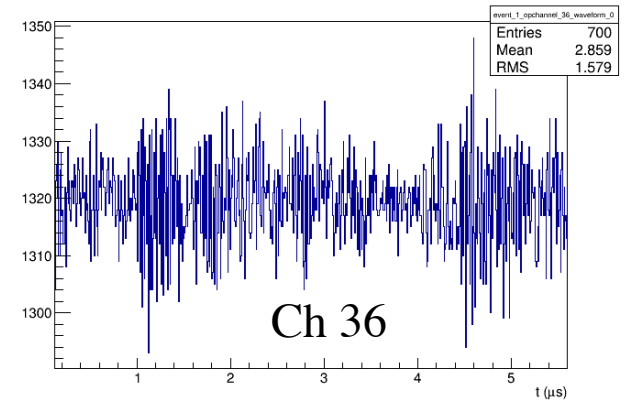
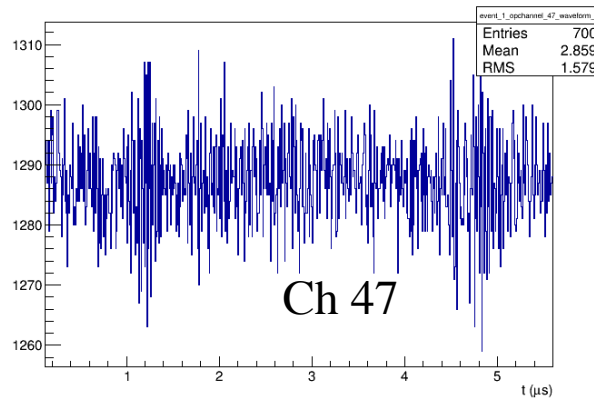
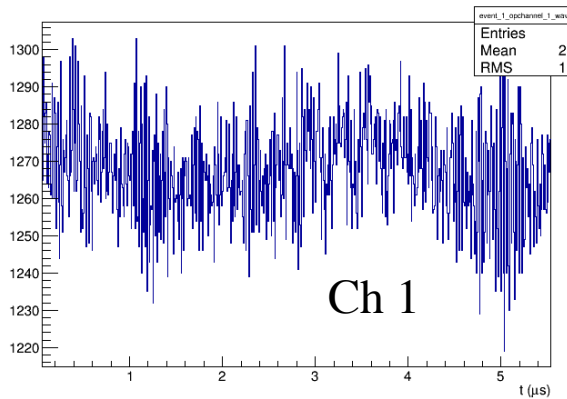

- “Slow” PD Channels: 65, 74

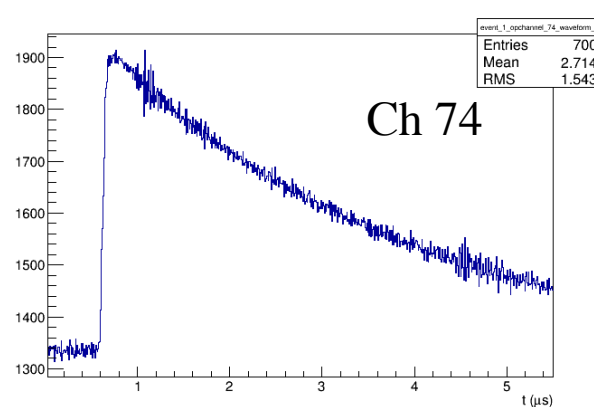
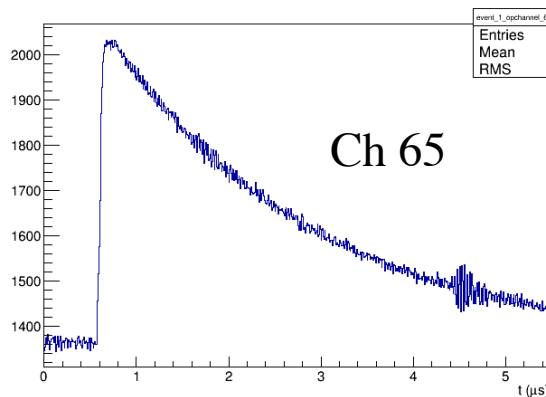

Noise PD Channels

- Channels with p.e. like noise: 16, 60, 61, 68, 69, 92, 93

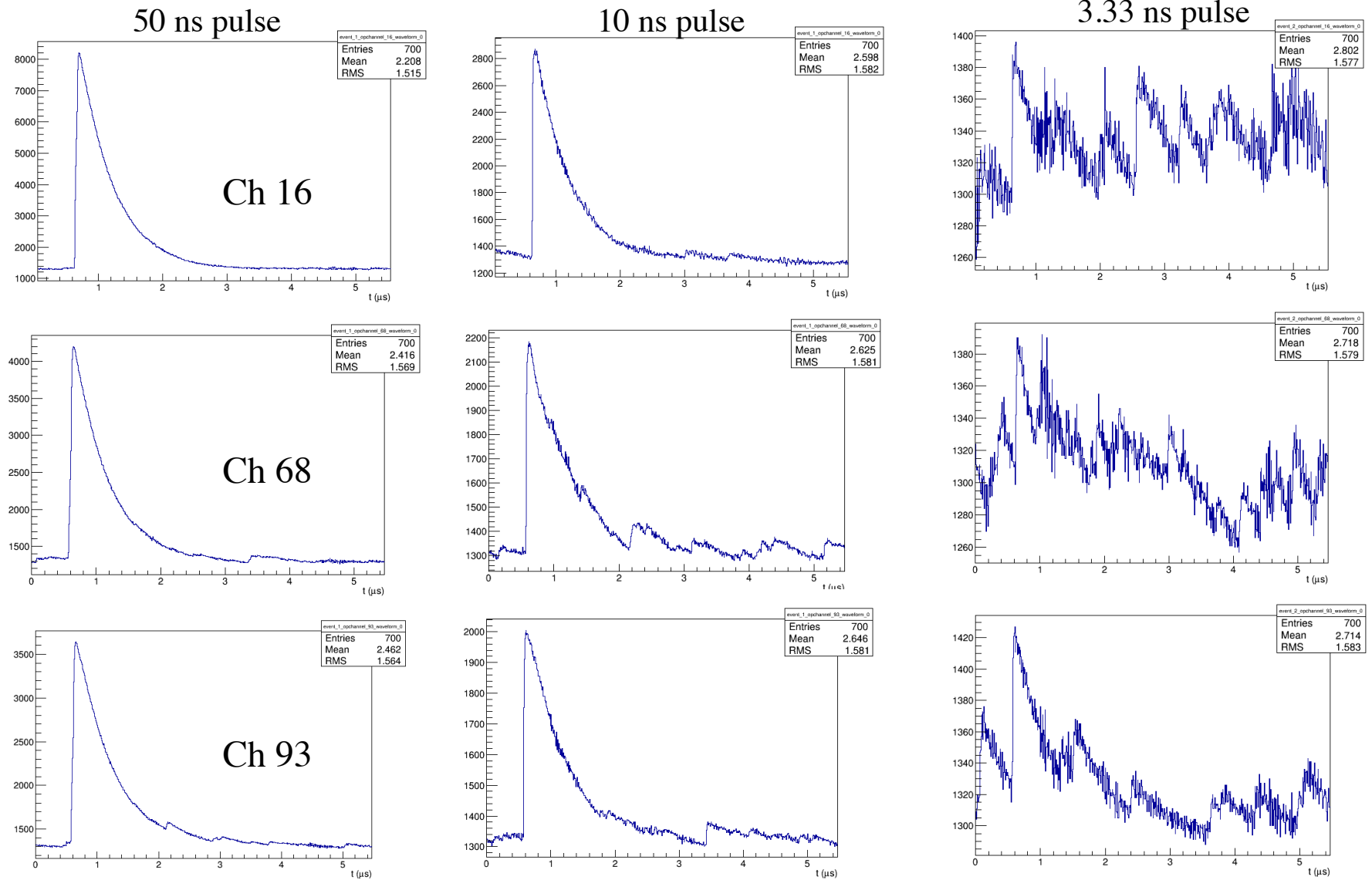

Going from 35t to protoDUNE

- Based on the calibration system has been designed, tested, installed, integrated, and operated with the 35-ton DUNE prototype detector => adapt it for protoDUNE.

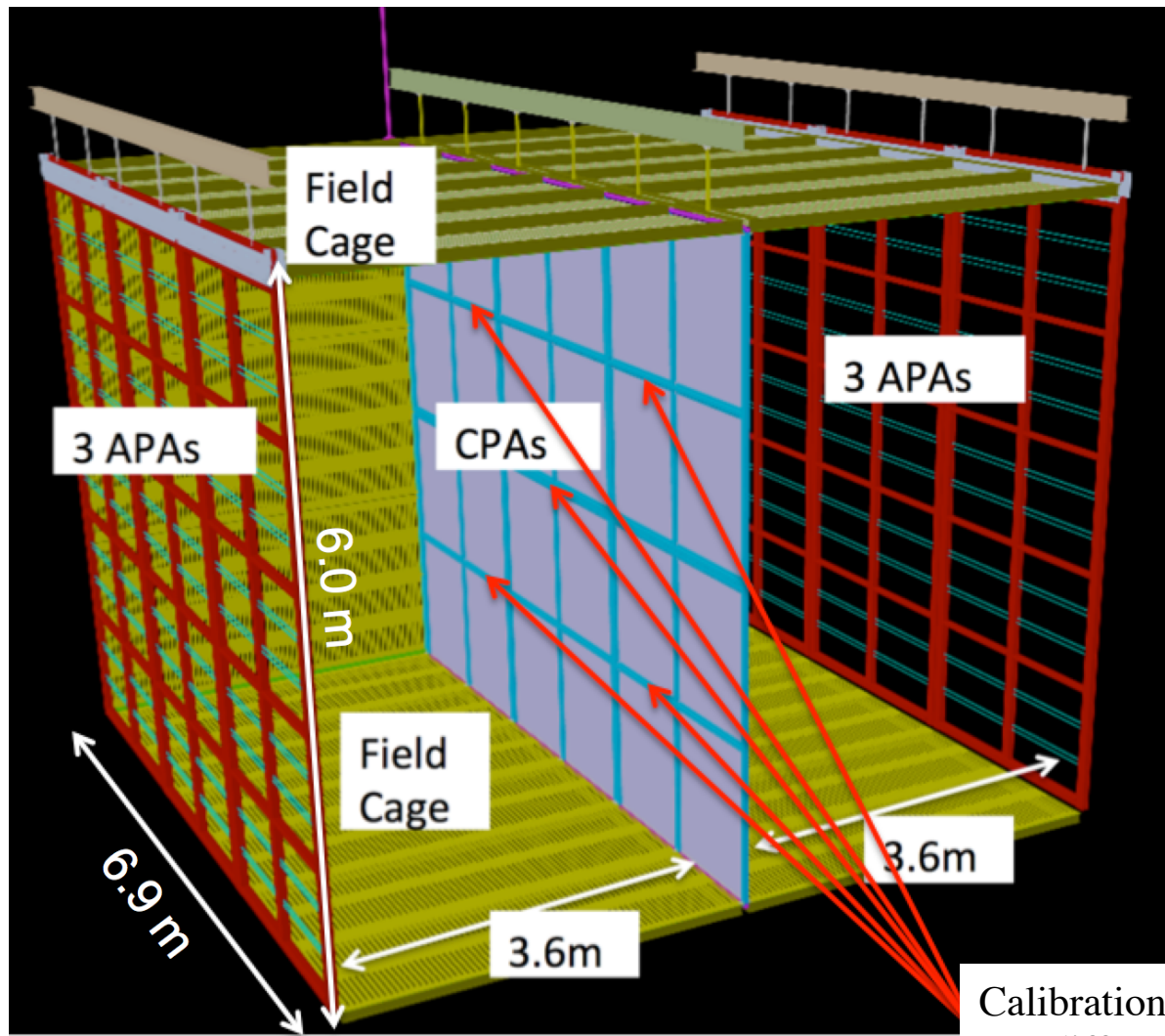

Calibration system
UV diffuser locations
At protoDUNE CPA

Diffuser Design for protoDUNE's CPA

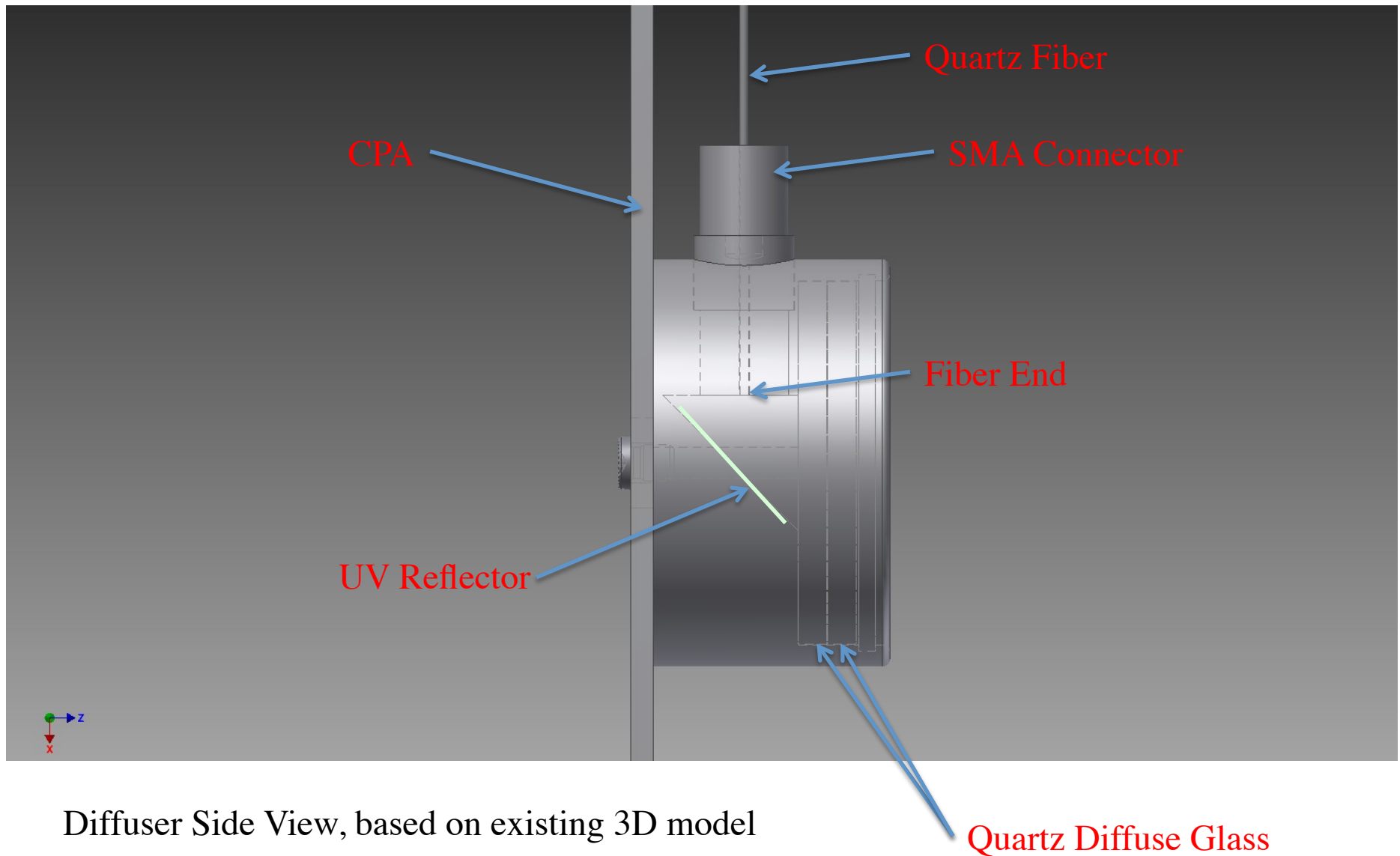

Diffuser Side View, based on existing 3D model

Diffuser Design for protoDUNE's CPA

Diffuser Front View



Diffuser Front Angular View

Interface to CPA

- Calibration components to be incorporated to CPA design
 - diffusers
 - fibers
- Provided 3D model to CPA group
 - calibration components will be added in next iteration of drawings
- (need add details on quartz fibers, fiber feedthrough, calibration module location)

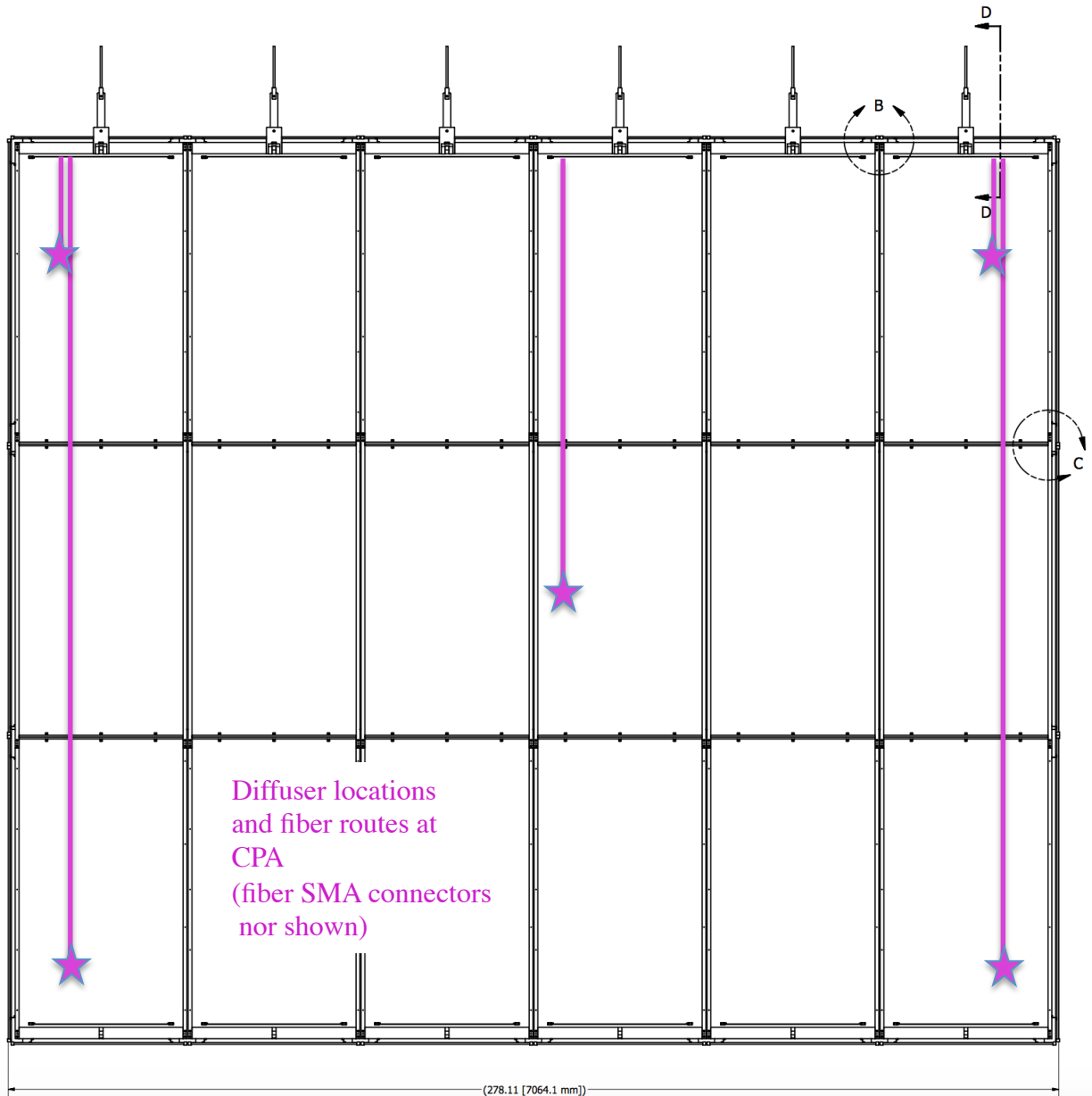

Interface to CPA

- Calibration components to be incorporated to CPA design
 - diffusers
 - fibers

- Provided 3D model to CPA group
 - calibration components will be added in next iteration of drawings

- (need add details on quartz fibers, fiber feedthrough, calibration module location)

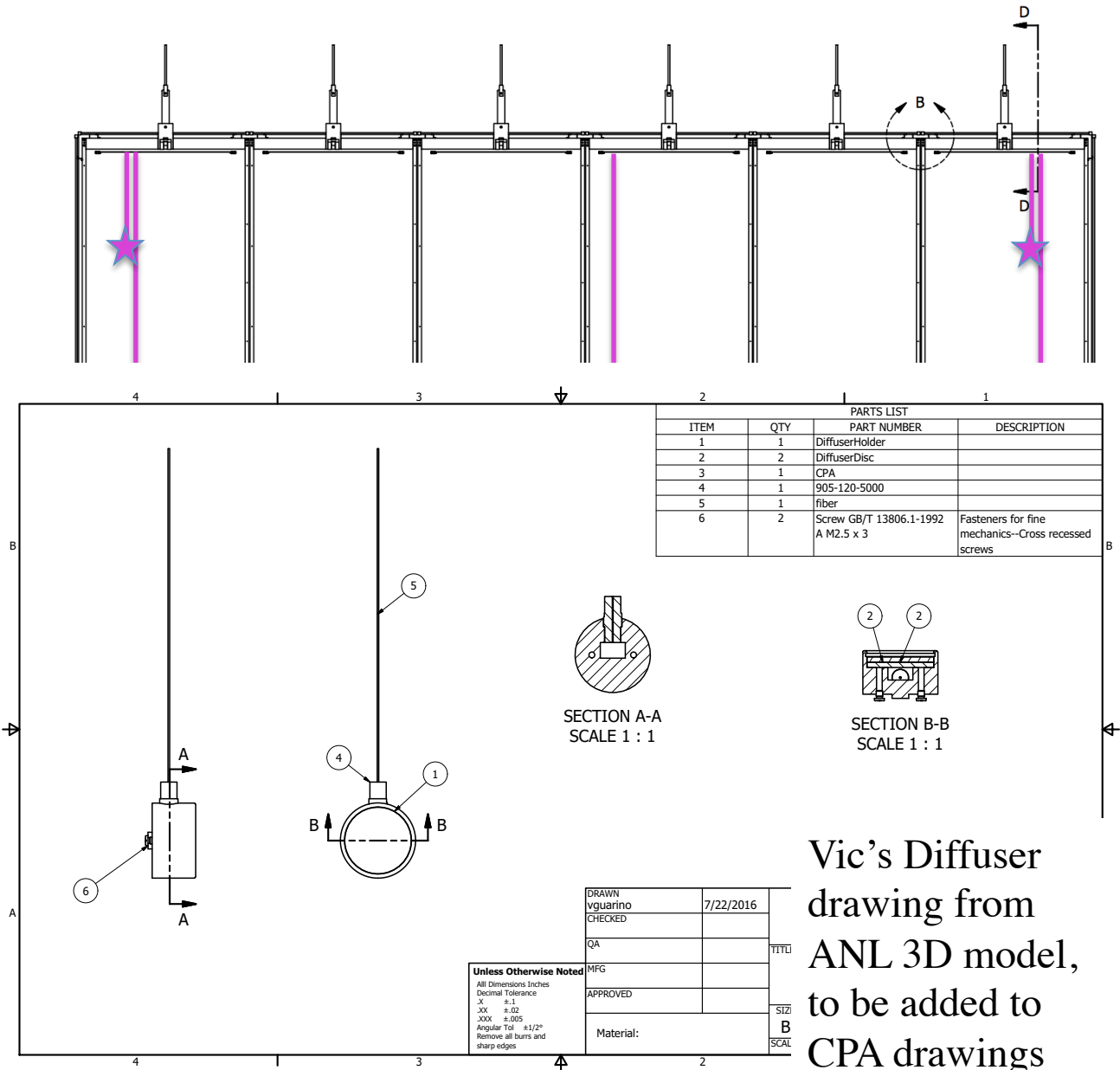

Vic's Diffuser drawing from ANL 3D model, to be added to CPA drawings

Expected Light Profile

- Simulated light distributions of at the APA location for the cases of the VUV light emitted by either
 - central diffuser only (left figure), or
 - outer four diffusers simultaneously (right figure).
- The simulation estimate has been obtained for 35-ton detector and scaled to 3.6 m CPA - APA distance at protoDUNE.

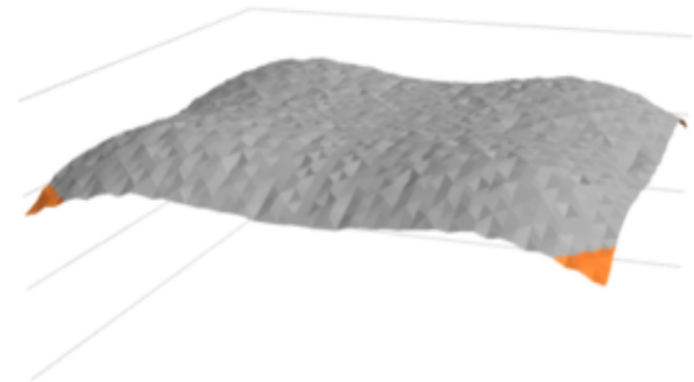
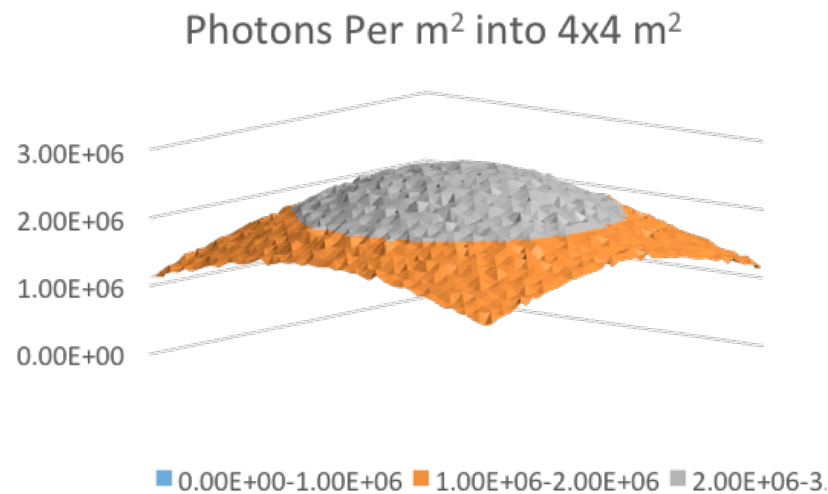

Schedule of Activities at CERN

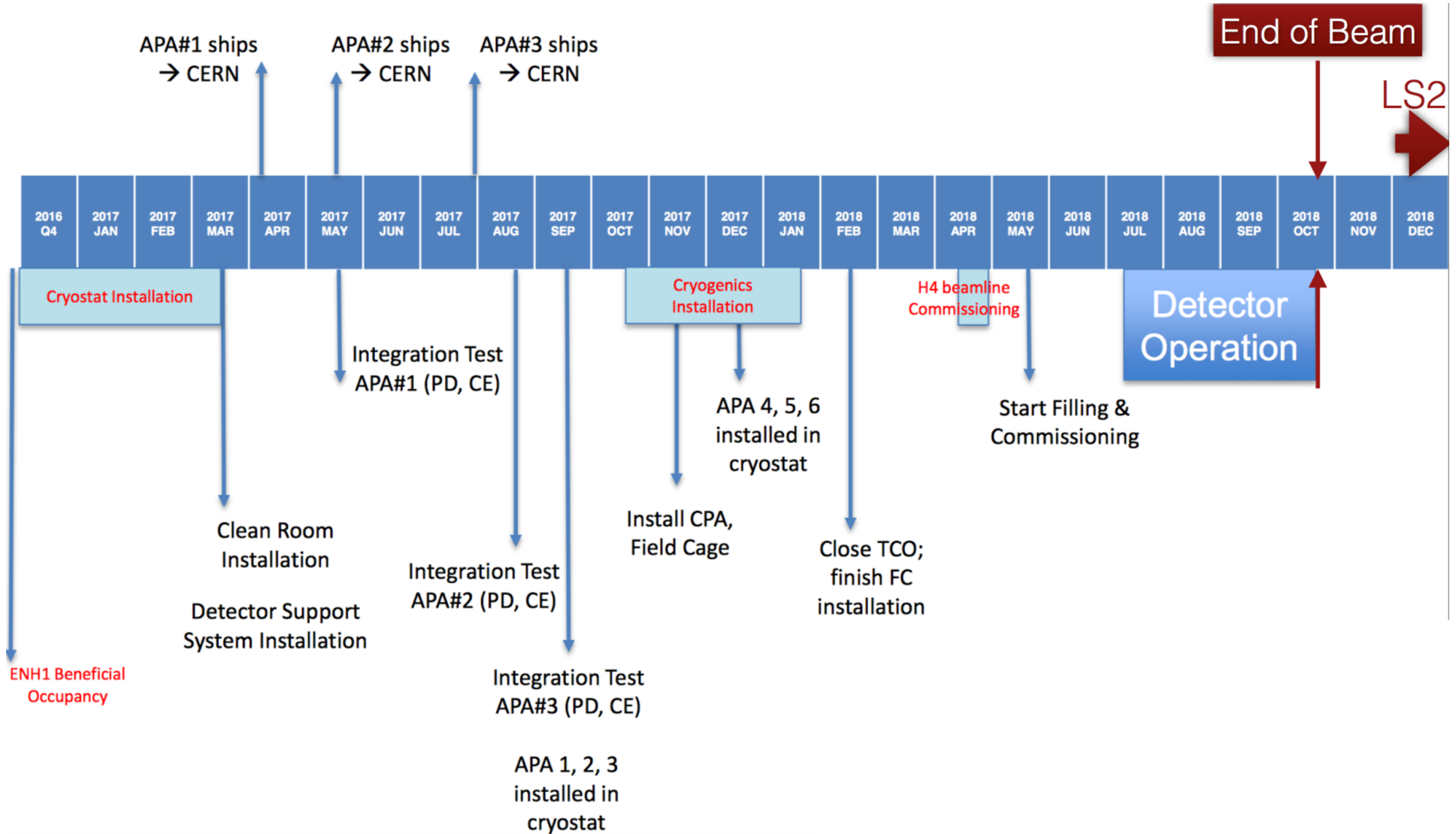

- Schedule under development
- PD calibration installation activities start with CPA installation at CERN in Oct 17

Next Steps

- Procure and fabricate components of the UV-light calibration system
 - Add five calibration channels (Calibration Module)
 - External and Internal fibers
 - Fiber feedthrough
 - Diffusers at CPA
- Develop protoDUNE Calibration Plan with PD, Calibration, Monitoring groups
- Components of the calibration plan
 - Initial “Dry” Run
 - Initial LAr Run (to set SiPM gains)
 - Initial Run to verify functionality of PD channels
 - Periodic runs to monitor stability of the system

Summary

- UV Light Calibration system designed for protoDUNE detector.
- Diffuse light from CPA to photo-detectors at APA.
- Prototype calibration module and fiber distribution systems built, tested, and operated in 35-ton detector
 - Large time and amplitude dynamic range with good uniformity
 - Collected data demonstrated successful operation
- Development will be continued toward 10 kt DUNE.
 - Next Step: protoDUNE Calibration.
- The calibration plan under developed with calibration and monitoring groups

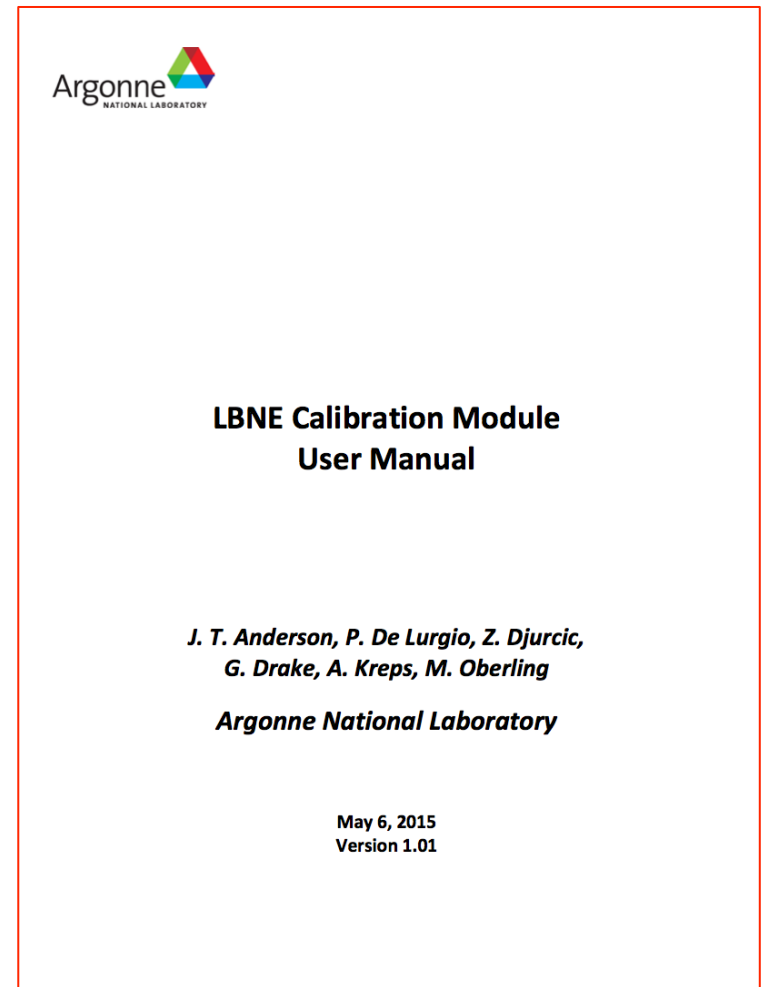

LBNE docdb-10842

Backups

Nominal 10 kt Detector Design

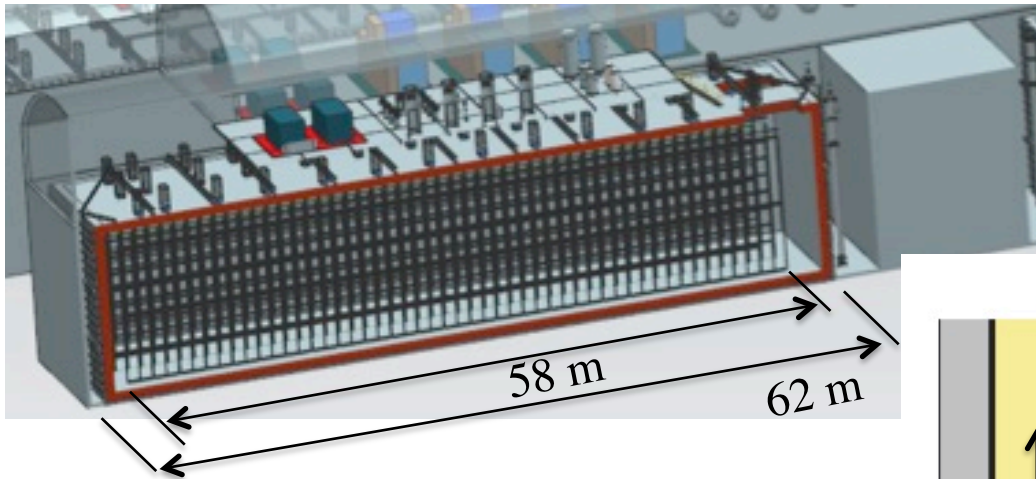

(slide from Jim Stewart)

Detector Module Characteristics

- 17.1/13.8/11.6 Total/Active/Fiducial mass
- 3 Anode Plane Assemblies (APA) wide
 - 3.6 m max drift length
- Cathode planes (CPA) are internal
- 58m long - 12m high - 14.4m active width

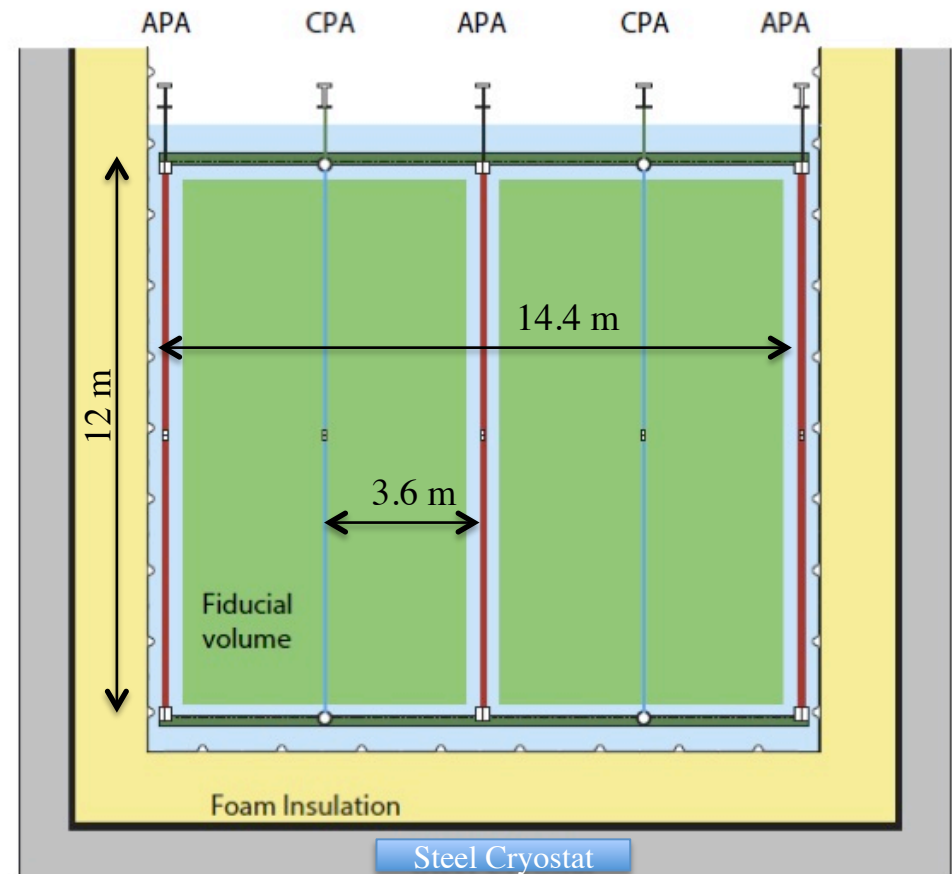

UV Light Calibration System in 10 kt DUNE detector

- Approach for DUNE 10 kton detector
 - install light diffusers at CPA
 - cover 4m x 4m APA area with a single diffuser

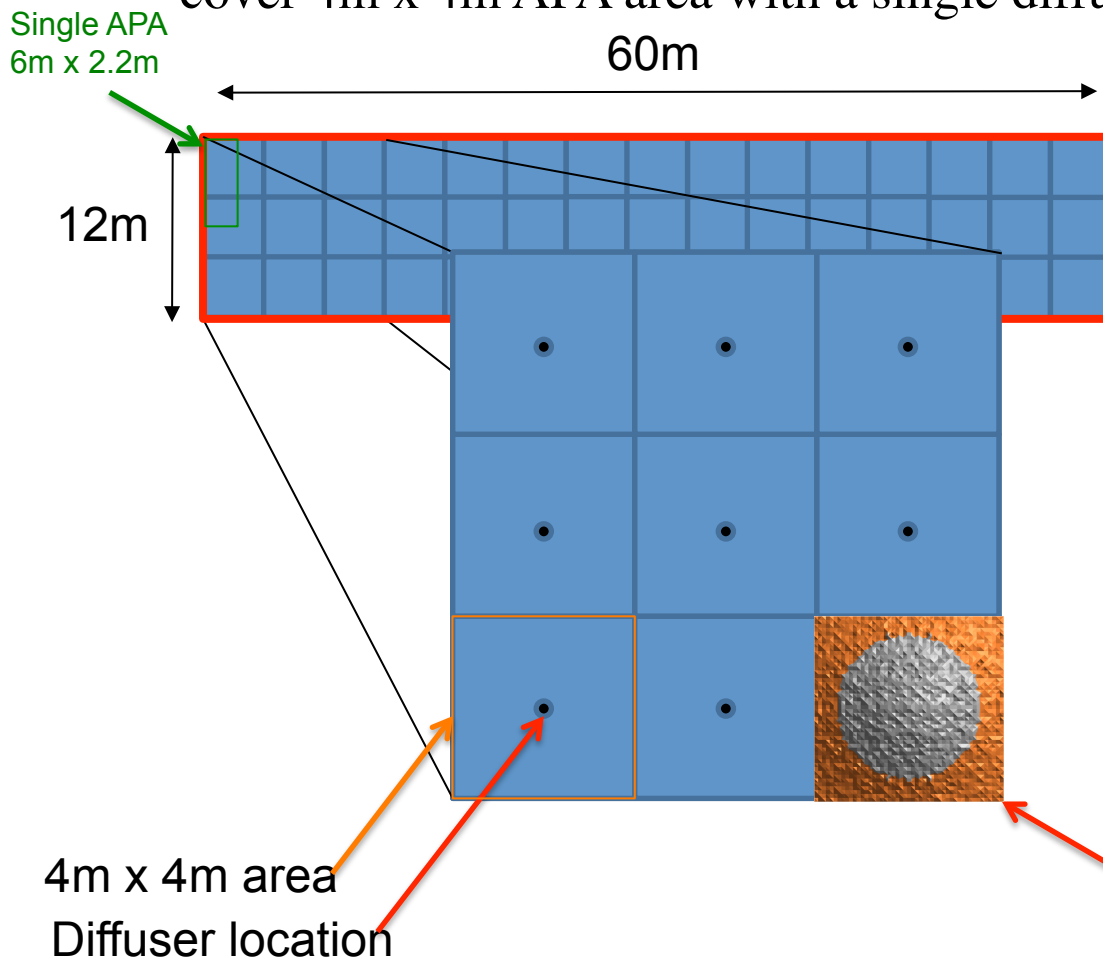

Photons Per m² into 4x4 m²

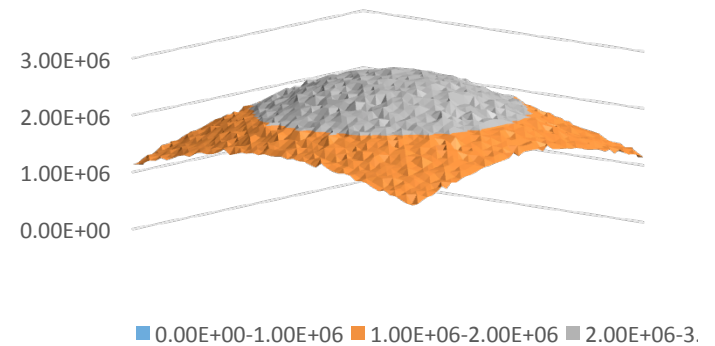

% STDEV	19%
Max	2.74E+06
Min	1.13E+06
Max/Min	2.425982
Average	1.96E+06

Simulated light response
at APA 4m x 4m area

Going forward to DUNE

- The DUNE photon-detector UV calibration system consists of a 1U rack mount Photon Detector Calibration Modules (PDCM) sitting outside the liquid argon cryostat.
- The module generates light pulses that propagate through a quartz fiber-optic cable to diffusers at cathode-plane (CPA) to distribute the light uniformly across the photon detectors mounted within anode plane (APA).
- For each optical channel there is feed-through connecting the external and internal fiber components.
- Each external fiber component is ~10m long and jacketed.
- A set of SMA connectors connect one fiber end to the PDCM, and another end to the feed-through. Each internal fiber piece is ~30m long with SMA connector at the feed-through end, linking it to the diffuser connector.

- We need 45 diffusers, fibers, and calibration module channels to cover an APA plane area of 12m x 60m in 10kt DUNE.
- A total of 135 channels will be needed for all three APA planes.
 - It may be realized with 12 calibration modules with 12 channels per module

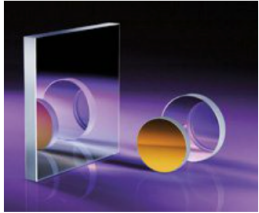

Stock No. #45-723

GO Edmund
optics | worldwide

TECHSPEC 10 x 10mm UV Enhanced Aluminum, λ/4 Mirror

\$42.00

1 - 5 for \$42.00 each.

6 - 25 for \$34.00 each.

Specifications

Dimensions (mm)	10.0 x 10.0
Dimensional Tolerance (mm)	±0.25
Clear Aperture (%)	85
Thickness (mm)	2.0
Thickness Tolerance (mm)	±0.25
Surface Flatness	λ/4
Surface Quality	60-40
Edges	Ground, 0.75 mm Maximum Full Width Bevel
Substrate	BOROFLOAT®
Coating Specification	R _{a v g} >85% @ 250 - 700nm
Typical Energy Density Limit	0.5 J/cm ² @ 355nm, 10ns
Wavelength Range (nm)	250 - 700
Wavelength Range (μm)	0.25 - 0.7
Type	Flat Mirror
Coating	UV Enhanced Aluminum
RoHS	C

- Need add pictures of the system components as cleaned and packed at ANL,
A picture from Bo with 35t installation .
- A picture of a CPA model with difusser at ANL

- A Dry 35t run waveform.
- A filled LAr 35t waveform? => talk with Alex Himmel?

- Need a summary of the calibration plan.

- Material from Patrick, to be done.=> talk to Patrick?

- What flange do we want? 4.75" or 6" for fiber feed-thoughts?

