

Photon Detector Calibration Monitoring System

Zelimir Djurcic, Patrick De Lurgio, Gary Drake,
Michael Oberling

Argonne National Laboratory
zdjurcic@anl.gov, drake@anl.gov

Outline of Talk

- Goals of the photon-detector monitoring system
- 35-ton Detector Prototype of the system
- Going from 35-ton to ProtoDUNE
- Next Steps
- Summary

Introduction

- **The Following Review Questions will be addressed (from the Charge):**
 1. **Does the Photon Detector System design enable validation and refinement of the DUNE photon detector requirements?**
 2. **Are Photon Detector System risks captured and is there a plan for managing and mitigating these risks?**
 3. **Does the design lead to a reasonable production schedule, including QA, transport, installation and commissioning?**
 4. **Does the documentation of the Photon Detector System technical design provide sufficiently comprehensive analysis and justification for the Photon Detector System design adopted?**
 5. **Is the Photon Detector system scope well defined and complete? Are all Photon Detector System interfaces to other detector components: APA, cryostat and DAQ systems documented, clearly identified and complete? Do the electronics feedthrough port and TPC integrated 3D models adequately represent the mechanical, electrical and electronic interfaces to the Photon Detector System? Is the cabling, power and calibration well defined and understood? Is the grounding and shielding understood and adequate?**
 6. **Are the Photon Detector System 3D model(s), top level assembly drawings, detail/part drawings and material and process specifications sufficiently complete to demonstrate that the design can be constructed and installed?**
 7. **Are operation conditions listed, understood and comprehensive? Is there an adequate calibration plan?**
 8. **Are the Photon Detector System engineering analyses sufficiently comprehensive for safe handling, installation and operation at the CERN Neutrino Platform? Is the installation plan sufficiently well developed? Is the design for installation tooling adequate for installing the photon system?**
 9. **Have applicable lessons-learned from previous LArTPC devices been documented and implemented into the QA plan? Are the Photon Detector System quality control test plans and inspection regimes sufficiently comprehensive to assure efficient commissioning and adequate operational performance of the NP04 experiment?**

Photon Detector Calibration Monitoring System

- The goals of the photon-detector monitoring system:
 - a) Verify that the channels are functioning properly
 - after photon-detector installation, before LAr filled
 - after LAr filled
 - b) Calibrate SiPM gains
 - c) Monitor the relative detector efficiency over time.
 - d) Monitor relative timing performance of the system.

UV Light Calibration System

- Photon Detector Calibration Monitoring System has been realized in a form UV-light flasher calibration system
- UV light calibration system design:
 - transports light from 275 nm UV LED sources through quartz fibers to the TPC volume
 - diffuse light to the photon detection system light collection elements
 - use UV light (will be wavelength shifted) to mimic physics of LAr scintillation light
 - observe SiPM response to shifted light.

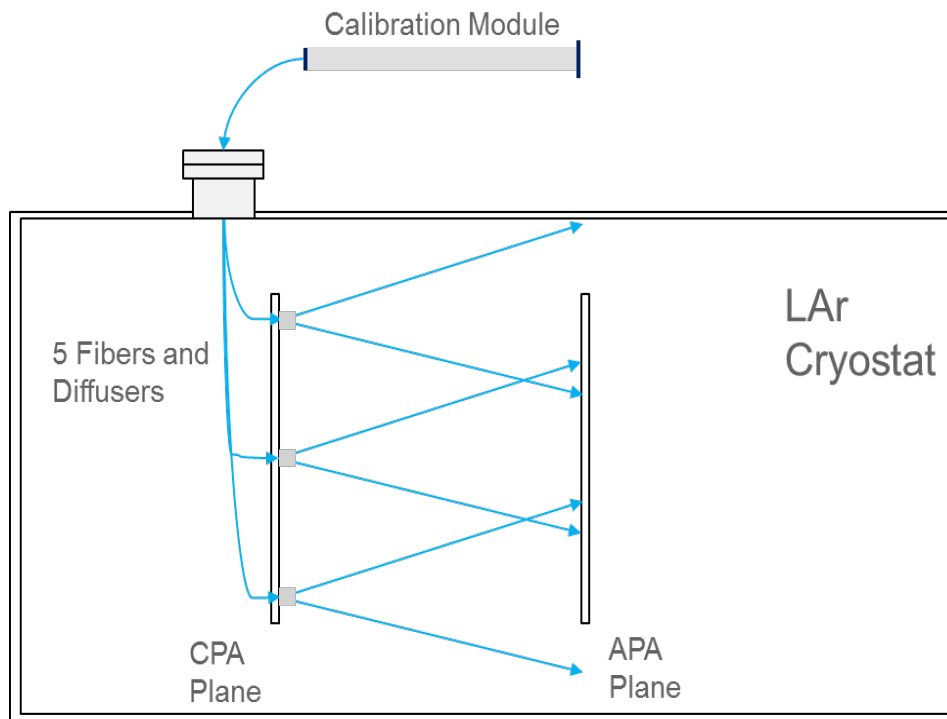

- Outer Components:
 - Optical quartz fiber
 - Calibration Module with 275nm LEDs
- Inner Components:
 - Light diffusers at CPA plane
 - Optical quartz fiber
 - Flange with fiber feed-through

Recent Status: 35ton DUNE Prototype

- The system has been designed, tested, installed, integrated, and operated with the 35-ton DUNE prototype detector

Photon Detector Calibration System Components

- Calibration module sources 5 UV LEDs (275nm)
- 275 nm light excites only wavelength shifter
- Quartz fibers deliver light to 5 diffusers mounted on CPA plane
- Diffusers distribute light onto photon detectors at APA plane
- One central Diffuser for Timing
- Four corner Diffusers for Uniformity/Gain
- Pulse widths from 5ns to 820ns
- Up to 25mW instantaneous optical power

Optical Simulation

- TracePro used for optical system design, simulation, and optimization

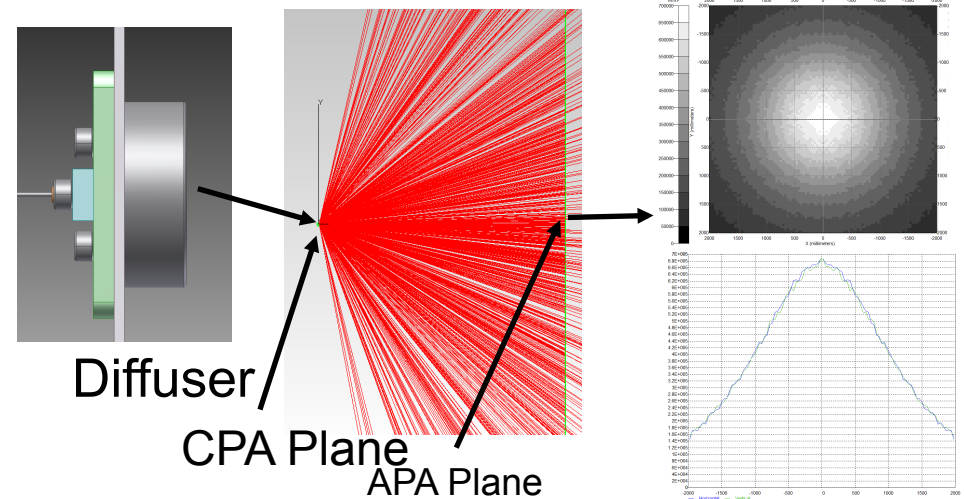
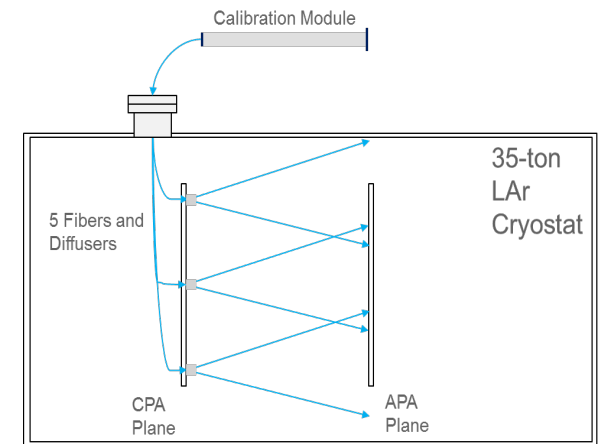

Optical Simulation of Single Diffuser at APA distance

Diffuser Implementation for 35-ton detector

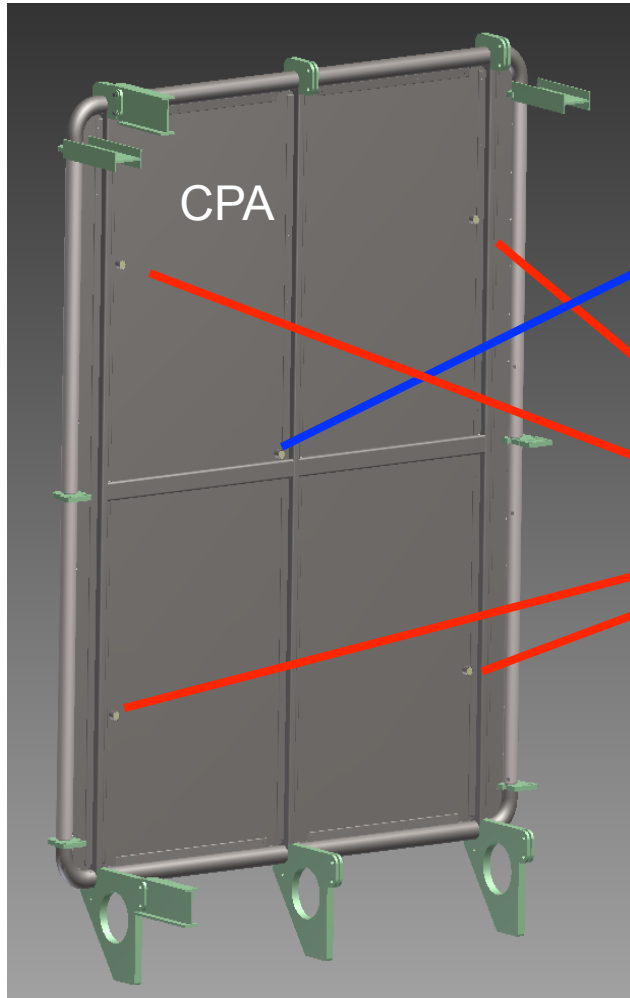
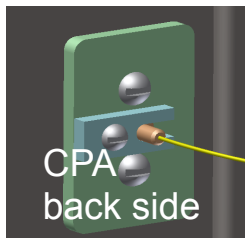
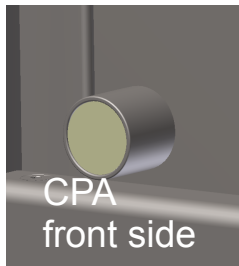

Central location timing calibration

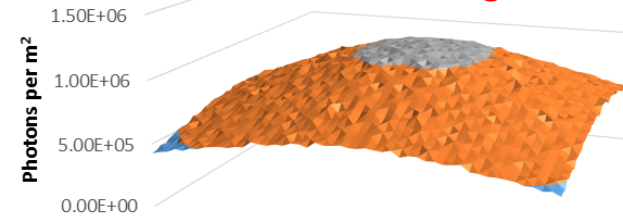

Photon distribution on 2x2 m² APA Plane

Max	~5E+06 photons/m ²
Min	~2.5E+06 photons/m ²
Max/Min	~2

4 corner locations gain calibration

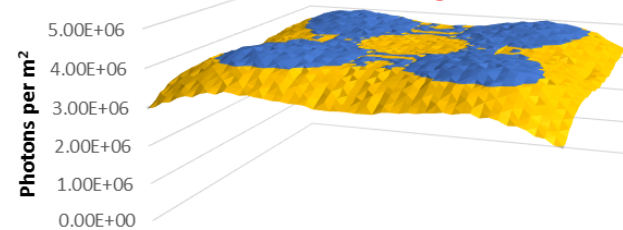

Photon distribution on 2x2 m² APA Plane

Max	~4.3 E+06 photons/m ²
Min	3.0 E+06 photons/m ²
Max/Min	1.44

DUNE Calibration Module

- Utilizes the SSP mainboard as a controller
Ethernet communication, timing control, internal/external triggering, etc.

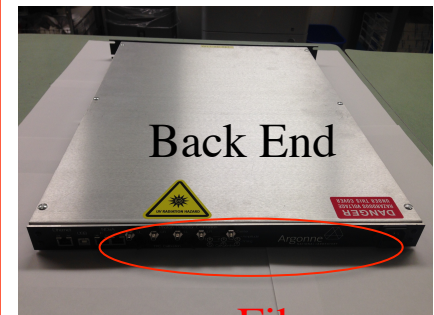
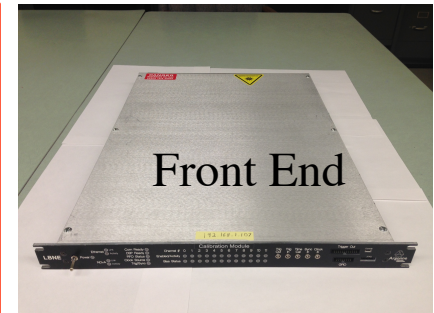
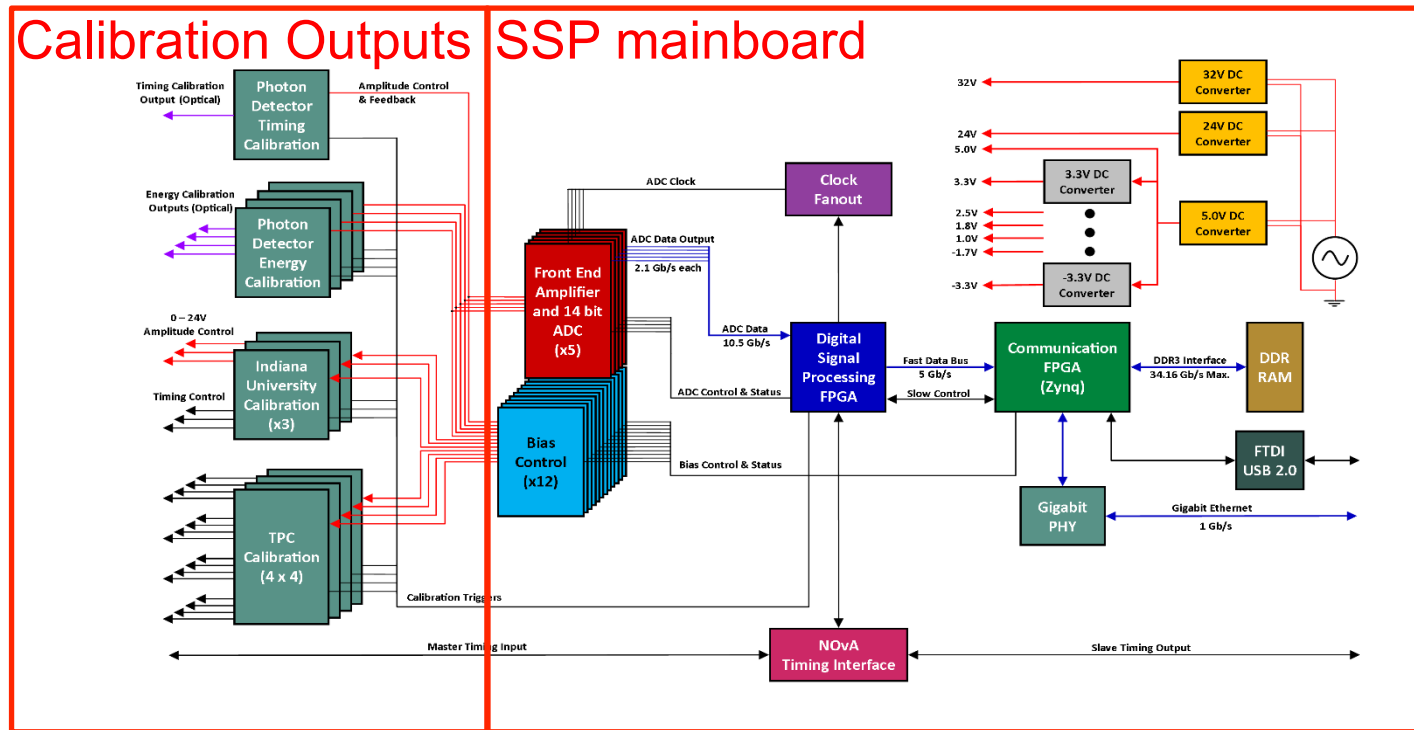

Fiber
SMAs

(also see the Backups)



Calibration Back-Panel



Components of the PD UV Calibration System

- Components installed with 35t DUNE prototype

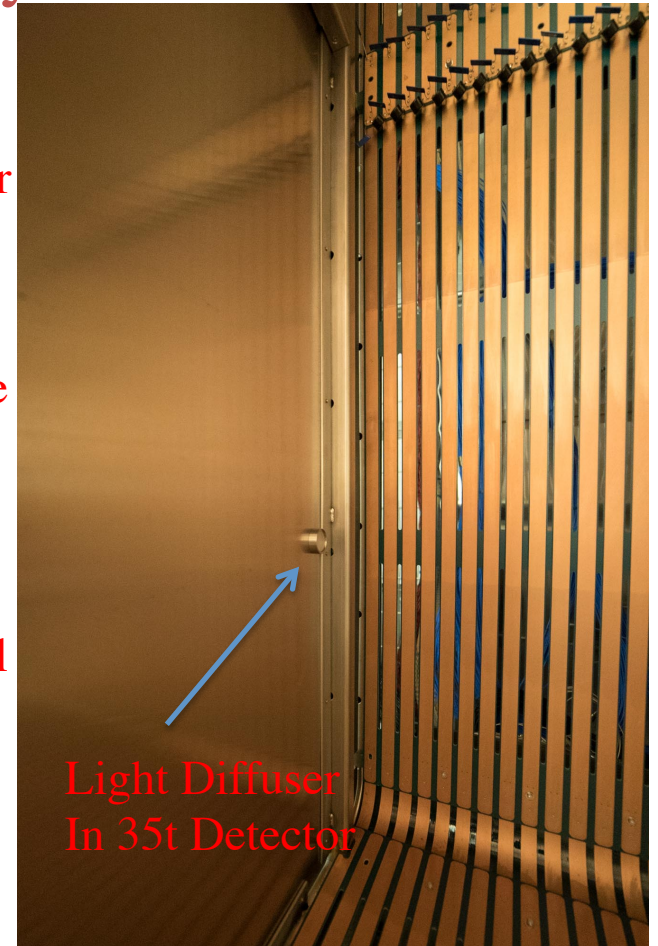
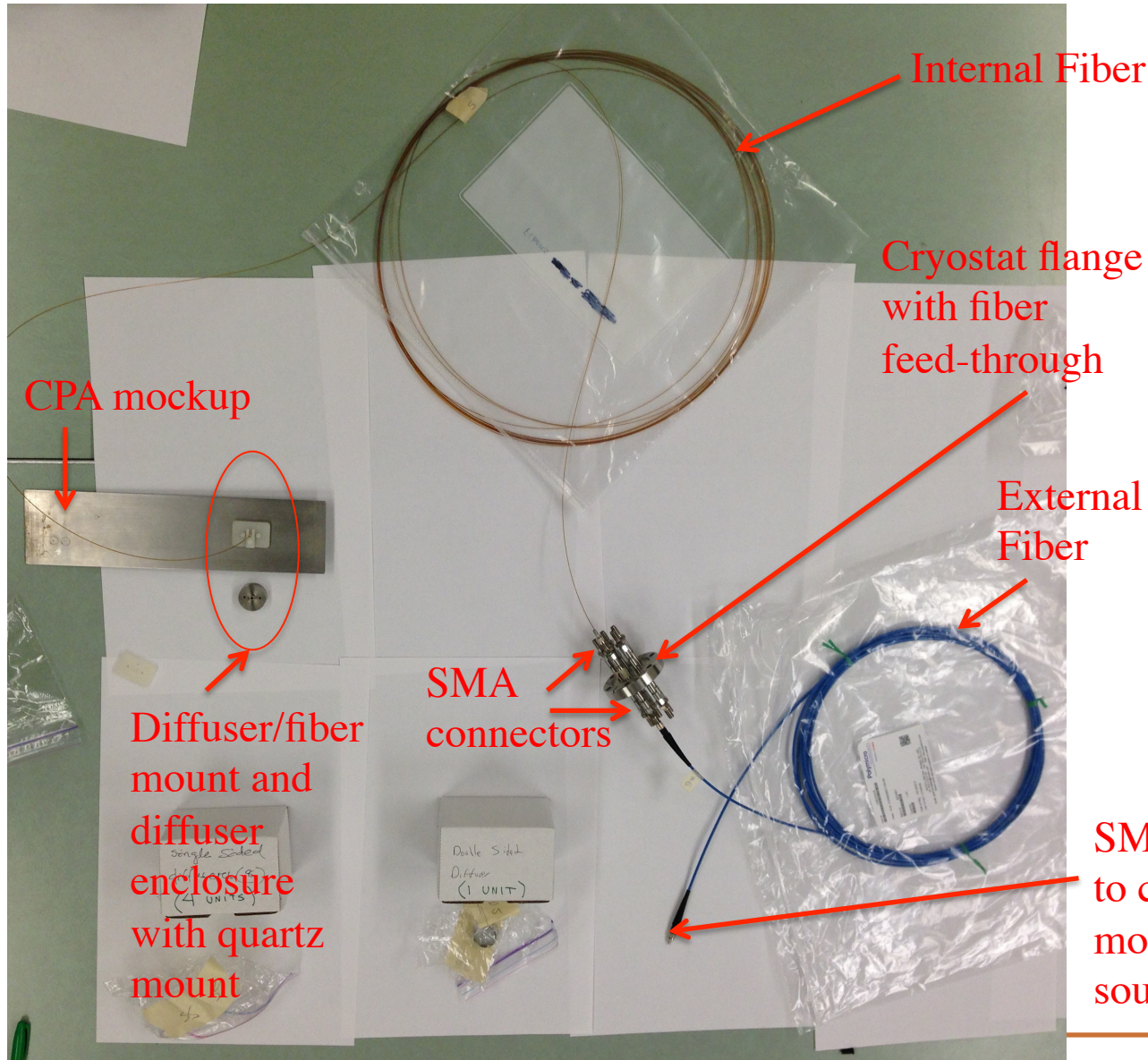

SMA connector to calibration module light source

(more figures in Backups)

35-ton Experience

- PD UV calibration system has been operational before the end of 35-ton run
- Collected calibration data demonstrated functionality of the calibration system and examined the functionality of the photon-detector channels
 - observe normal channels (i.e. standard response)
 - discover noise channels
 - discover malfunctioning PD channels
- We have collected data with all five UV-light diffusers with different pulse lengths and pulse heights
 - analysis underway
- Example of PD Calibration Runs in next two slides
 - central diffuser only
 - pulse width = 50, 10, 3.33 ns
 - pulse amplitude 30 V
 - pulse frequency 143 Hz

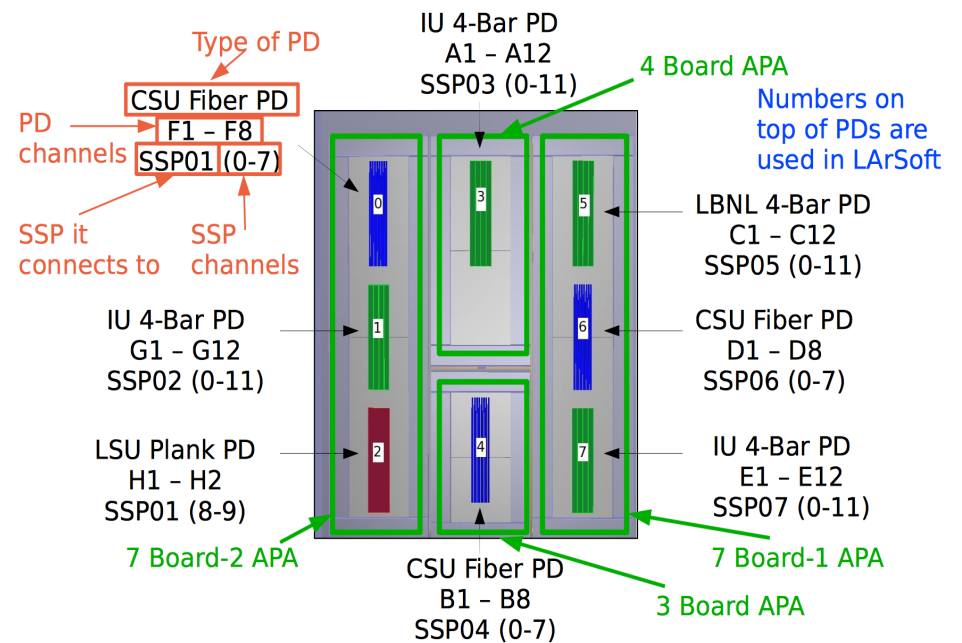

PD Channels with Standard Response

- Standard Channels

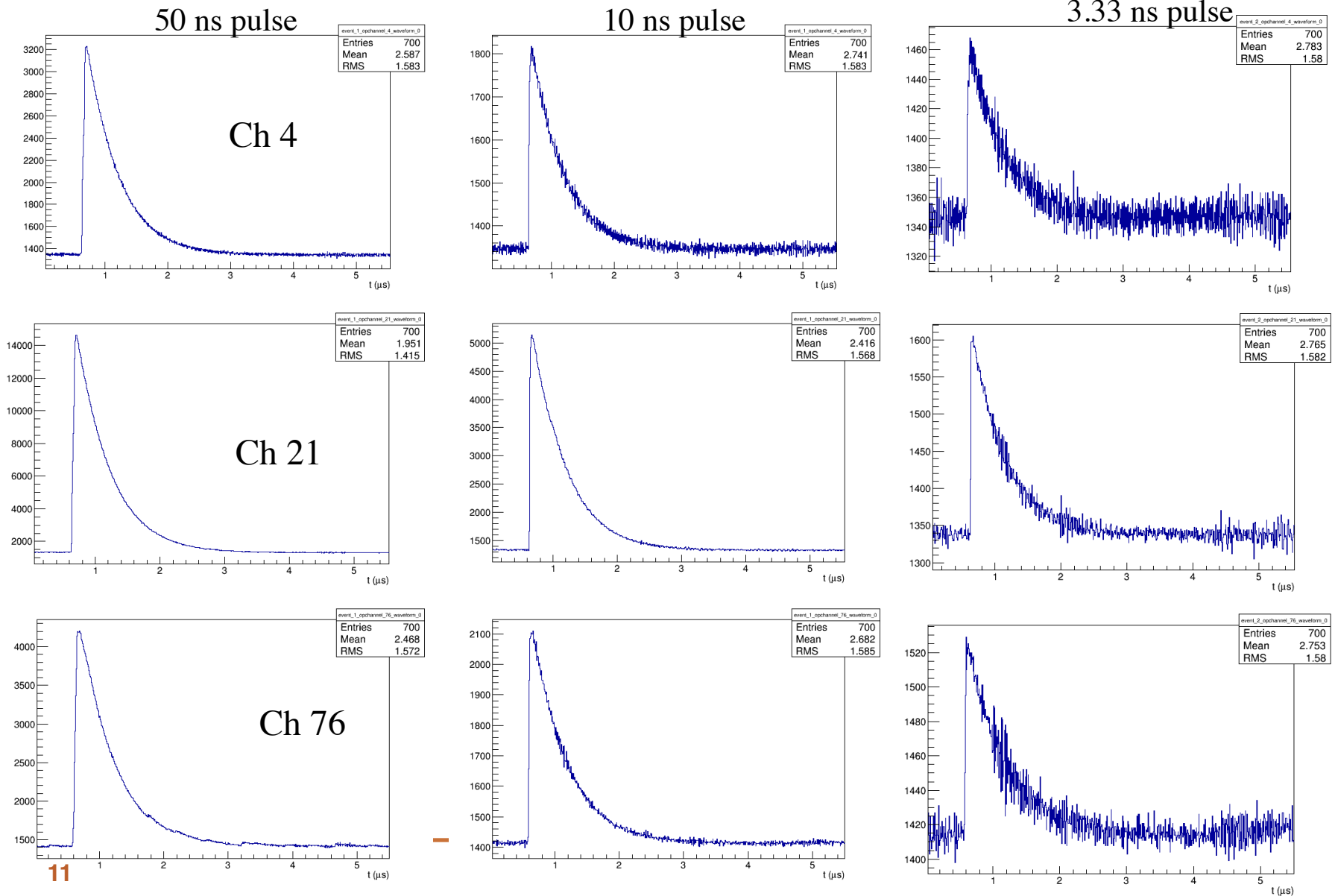

Malfunctioning and non-standard PD Channels

- Malfunctioning Channels

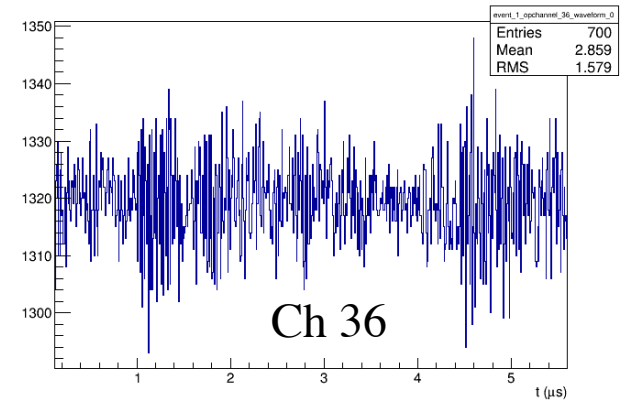
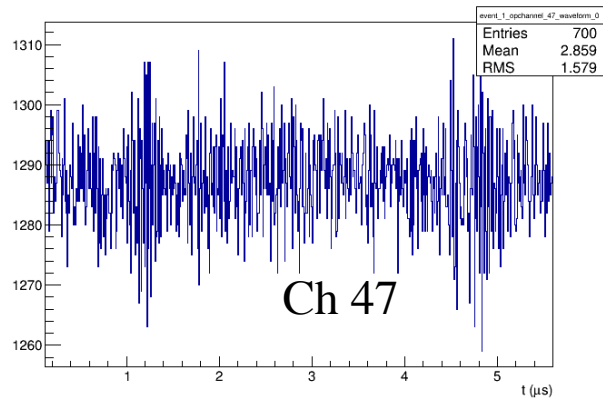
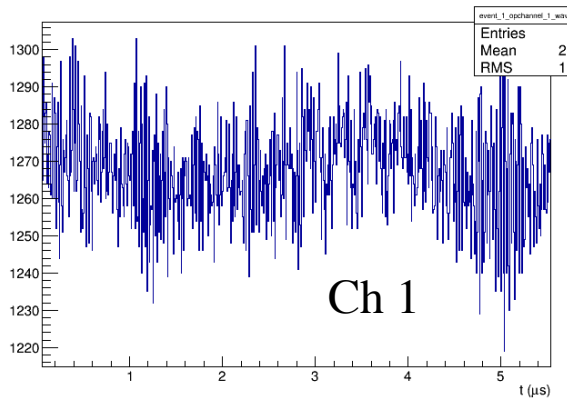

- “Slow” PD Channels

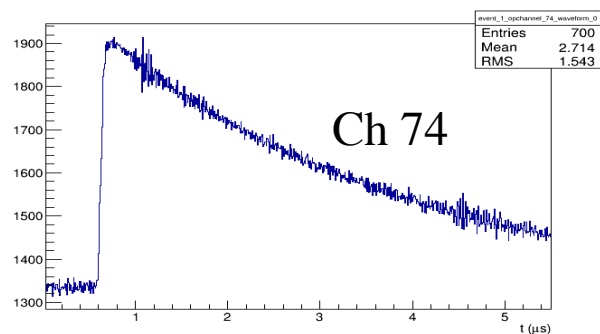
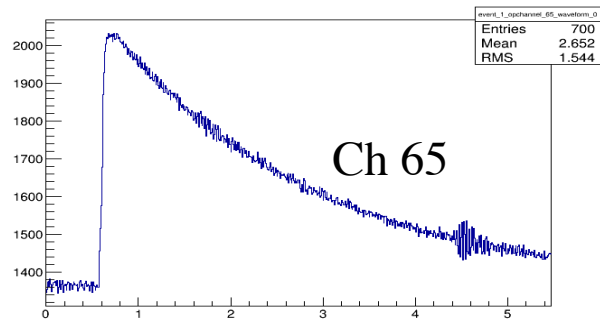

- Channels with p.e.-like noise

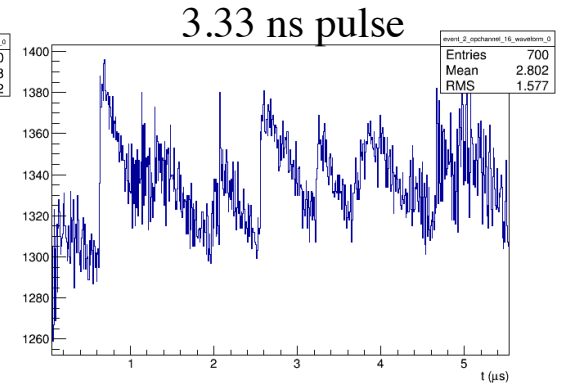
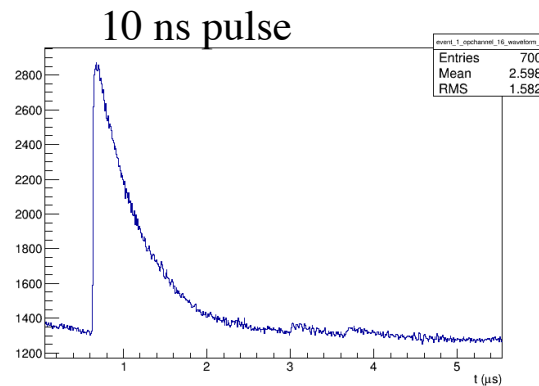

Going from 35-ton to protoDUNE

- The prototype photon-detector UV-light calibration system has been implemented and tested with 35-ton detector
- Based on 35-ton experience we will re-design the system to used with the protoDUNE
- The system has been designed under following assumptions:
 - simple to implement (no active components within APA).
 - uniformly illuminates APA surface with the light diffused from CPA locations
 - has a potential to be adapted for deployment in a large Far Detector in the future
- In terms of technical requirements the system needs to:
 - uniformly illuminate the APA area of the detector
 - provide light levels down to a single P.E. at individual photon-detector channels
 - provide variable pulse width to test the time resolution of the photon- detector response

Going from 35-ton to protoDUNE

- Based on the calibration system has been designed, tested, installed, integrated, and operated with the 35-ton DUNE prototype detector => adapt it for protoDUNE.

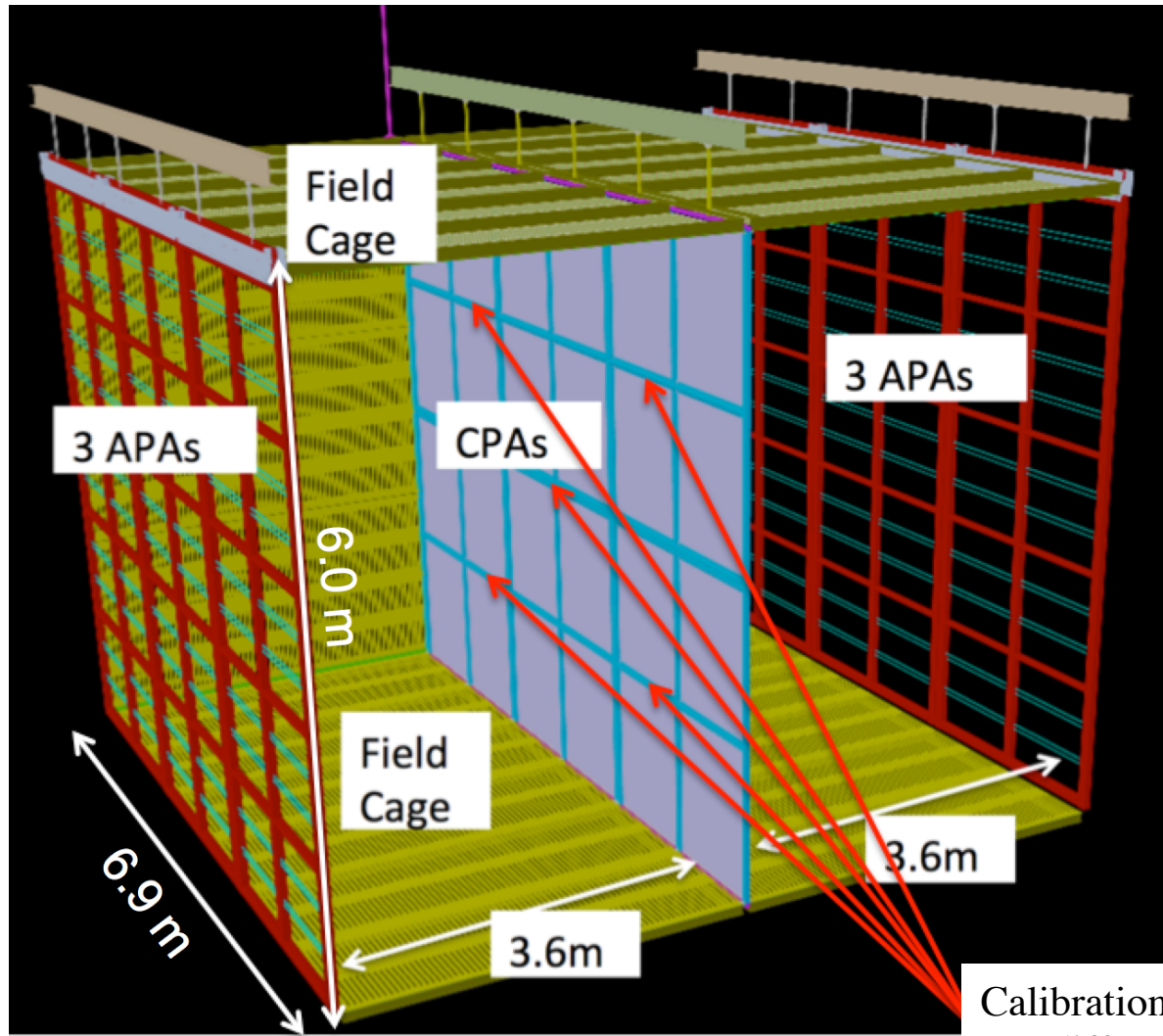

Calibration system
UV diffuser locations
At protoDUNE CPA

Diffuser Design for protoDUNE's CPA

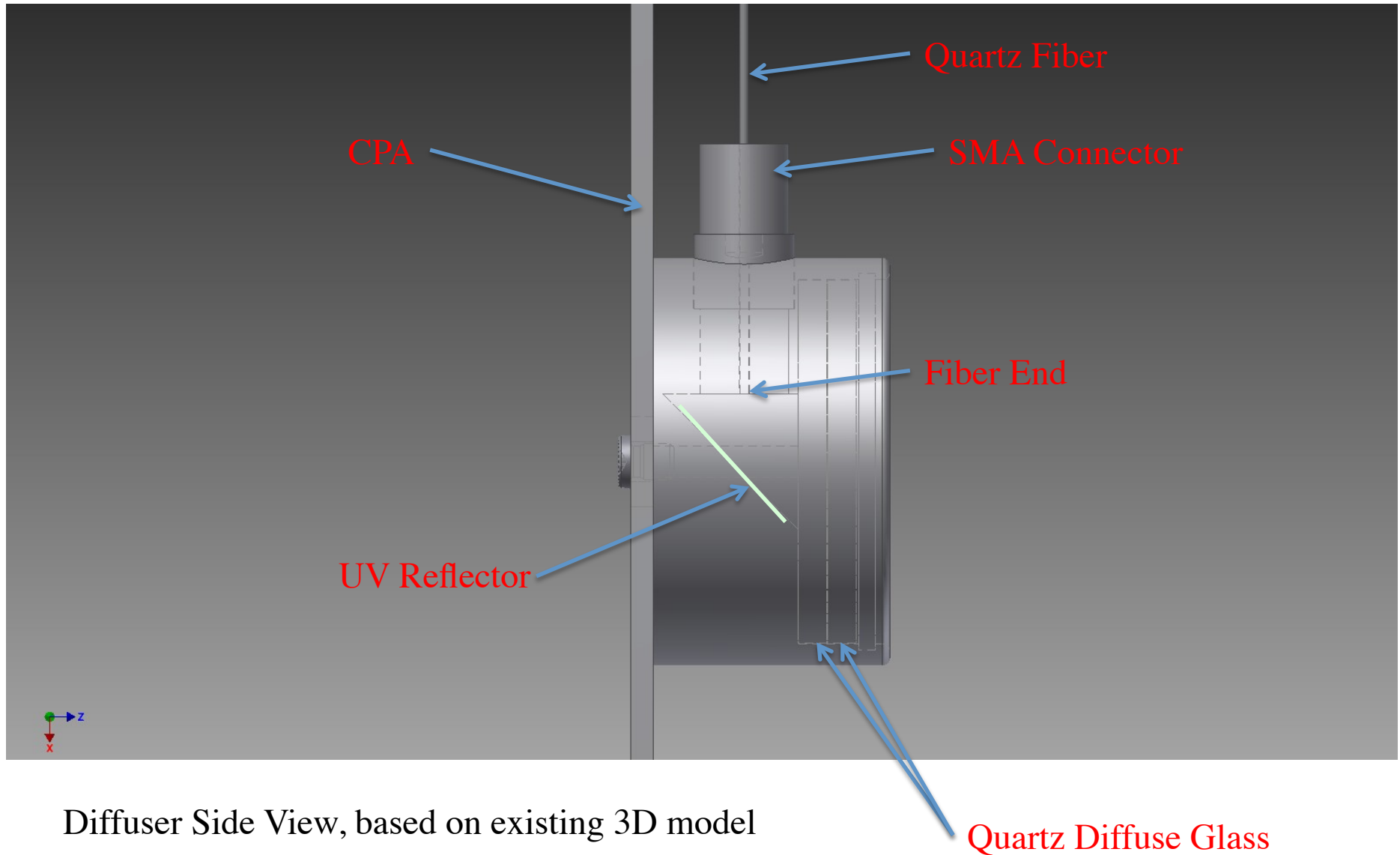

Diffuser Side View, based on existing 3D model

Diffuser Design for protoDUNE's CPA

Diffuser Front View



Diffuser Front Angular View

Interface to CPA and Cryostat

- Calibration components to be incorporated to CPA design
 - diffusers
 - fibers
- Provided 3D model to CPA group
 - calibration components being added in current iteration of drawings
- Will use identical fiber feed-through developed with 35-ton
- Identical quartz fiber will be used
 - length between 13 and 18m
- Discussion underway with Grounding/Shielding
 - decide calibration module location (SSP-like)

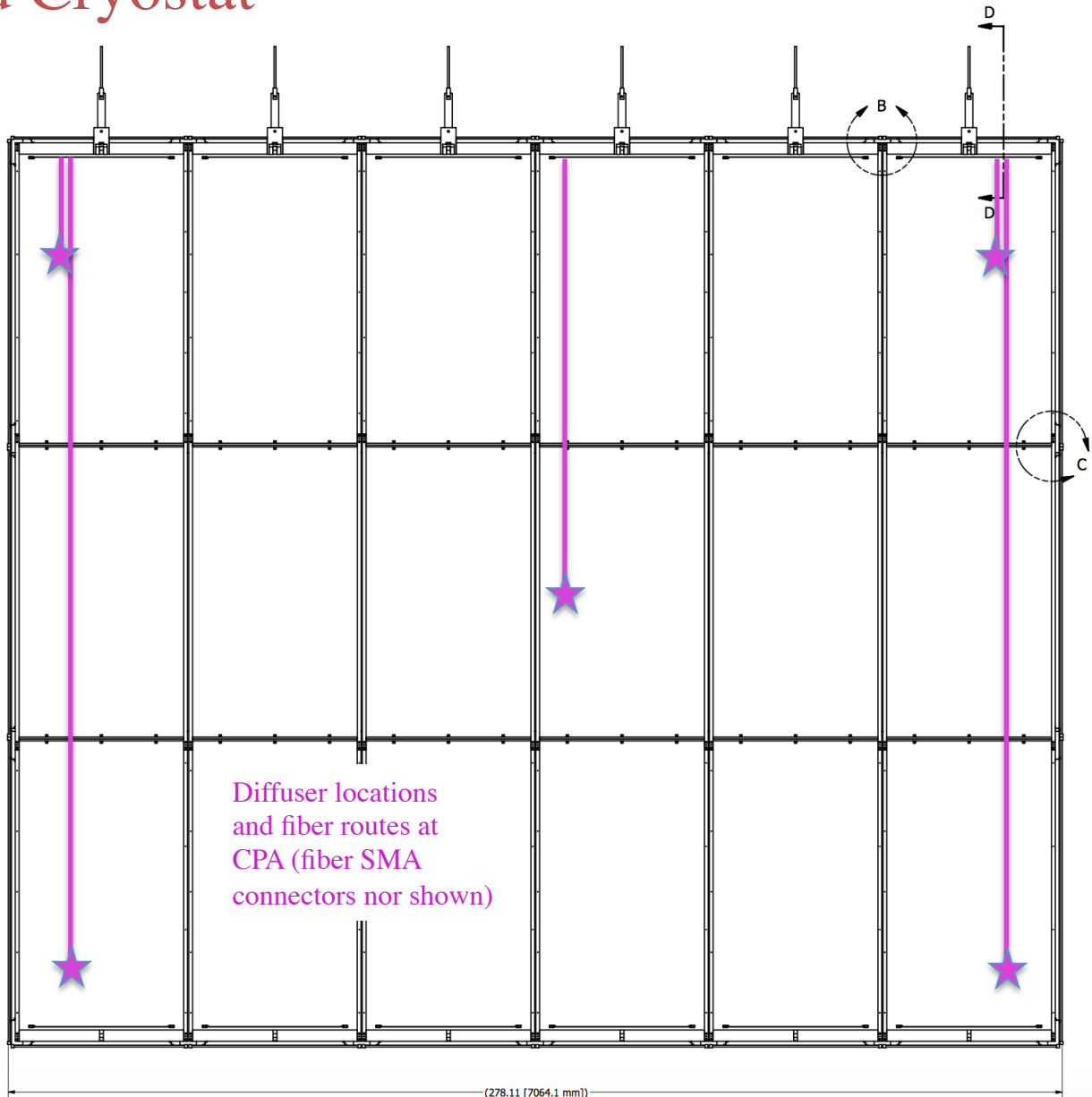

Interface to CPA and Cryostat

- Calibration components to be incorporated to CPA design
 - diffusers
 - fibers
- Provided 3D model to CPA group
 - calibration components being added in current iteration of drawings
- Will use identical fiber feed-through developed with 35-ton
- Identical quartz fiber will be used
 - length between 13 and 18m
- Discussion underway with Grounding/Shielding
 - decide calibration module locations (SSP-like)

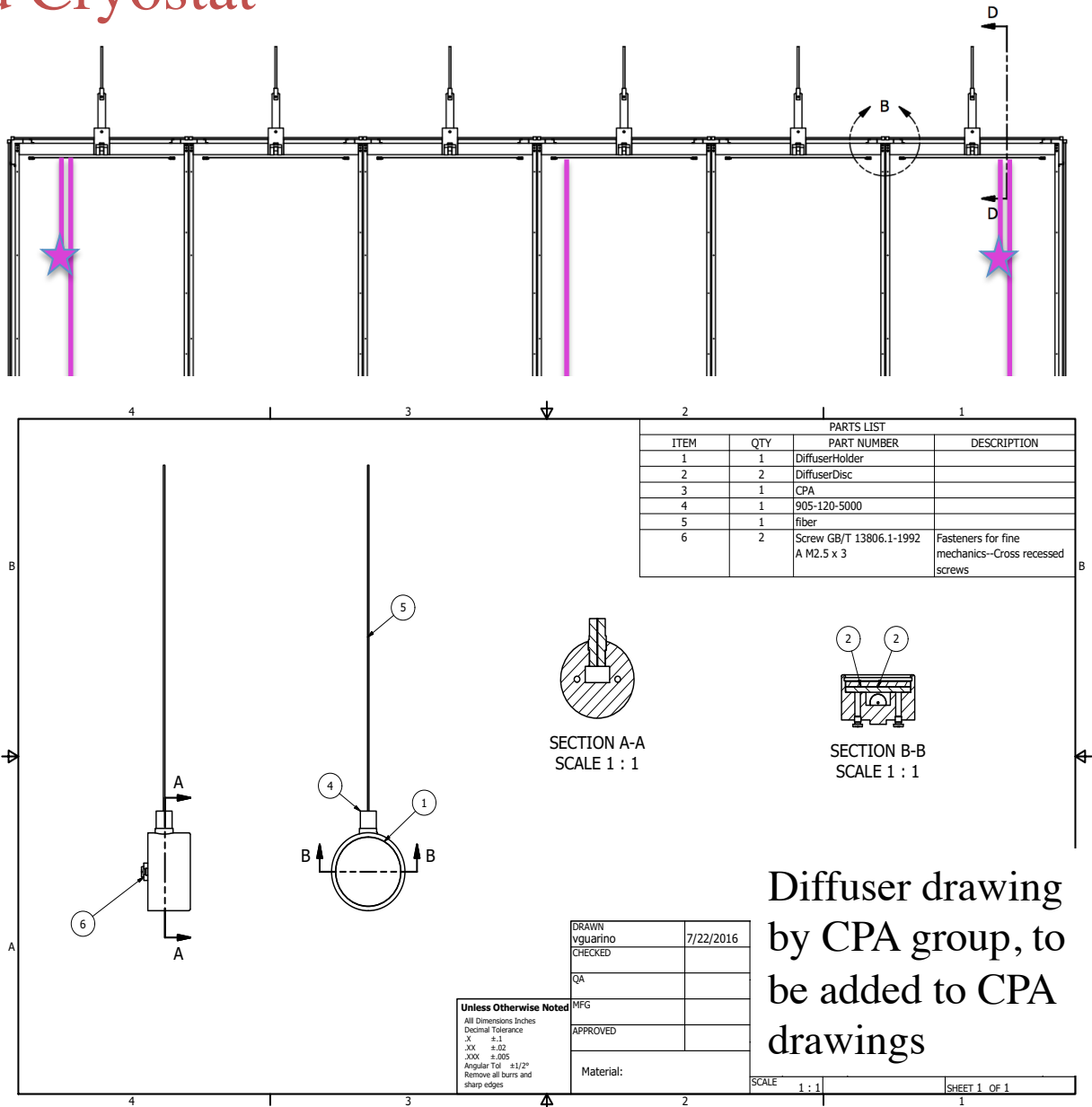

Diffuser drawing by CPA group, to be added to CPA drawings

System Components: Parts

- Components Identified
 - based on 35-ton prototyping: adopt same fiber, SMA-connectors, flange design, SS and quartz diffuser materials for CPA flasher units
- Examples:



Please address all Purchase Orders to:
MOLEX INCORPORATED
 18019 North 25th Avenue, Phoenix, AZ 85023-1200
 Tel: 602-375-4100 Web: www.molex.com/polymicro
 Fax: 630-813-9995 E-Mail: gary.macdonald@molex.com

TO: Raquel C. Young
 Argonne National Laboratory
 Bldg. 362 RM E 245
 9700 South Cass Avenue
 Argonne, IL 60439-4815

Date 19-Feb-15
 Quote # 27501GM
 Telephone 630-252-6290 (direct)
 Fax NA
 E-Mail ryoung@anl.gov

Estimated Lead Time 3-5 Weeks ARO Ship Via

FCA

Terms Net 30 Pending Approval

QUANTITY	UOM	Existing Part#	DESCRIPTION	UNIT PRICE USD	TOTAL*
7	Each	TBD	FOA, FVP600660710/8.5M Fiber Optic Assembly		

Fiber: FVP600660710
 NA = 0.22 ± 0.02
 Overall Length: 5m ± 10cm
 Proximal end finish: SMA 905
 Distal end finish: SMA 905
 Jacket: Black Hytrel Tubing

Fiber part:
 Polymicro
 FVP60060710

SILICA/SILICA Optical Fiber FV

• High -OH

Characteristics

- Step Index
- Numerical Aperture: 0.22 ± 0.02
- Full Acceptance Cone: 25.4 degrees
- UV-Vis-NIR Transmission, 180nm to 1,150nm
- Superior Radiation Resistance
- High Laser Damage Threshold
- Sterilizable & Bio-compatible – USP Class VI*
- High -OH Silica Core, Doped Silica Clad
- Polyimide Buffer Standard; Silicone, Acrylate, High-Temperature Acrylate also available.
- Polyimide Concentricity < 3µm
- Sizes for Bundling
- Tighter Tolerances Available
- Temperature: Operating –65°C to +300°C Intermittent, up to 400°C
- Proof Tested to 100kpsi

Product Descriptor	Core (µm)	Clad (µm)	Buffer (µm)
FVP050055065*	50 ± 2	55 ± 2	65 ± 2
FVP100110125**	100 ± 3	110 ± 3	124 ± 3
FVP150165195	150 ± 3	165 ± 3	195 ± 5
FVP200202040	200 ± 4	220 ± 4	239 ± 5
FVP300303070	300 ± 6	330 ± 7	370 ± 10
FVP400404080	400 ± 8	440 ± 9	480 ± 7
FVP60060710	600 ± 10	660 ± 10	710 ± 10
FVA8008801100***	800 ± 20	880 ± 15	1100 ± 30
FVP100120140	100 ± 3	120 ± 3	140 ± 4
FVP200240280	200 ± 4	240 ± 4	275 ± 5
FVP320385415	320 ± 8	385 ± 8	415 ± 10
FVA100010501250***	1000 ± 20	1050 ± 15	1250 ± 40

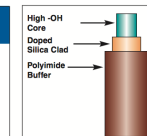

Note: The items listed in this table are standard configurations and sizes. Other configurations may be available on request. Please let us know what we can do to help satisfy your project requirements.

* Recommended for UV wavelengths only. Availability varies.

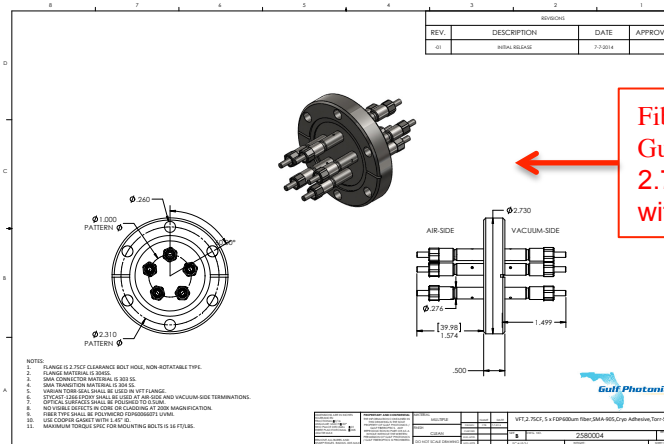
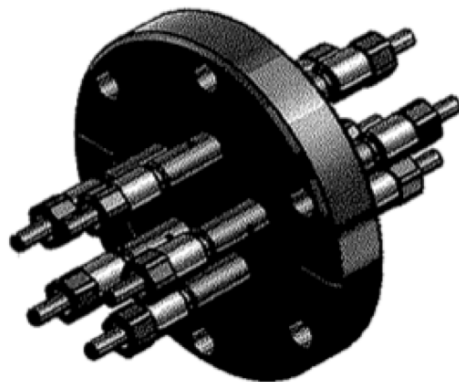

Fiber feedthrough part:
 Gulf Photonics:
 2.75" diameter Conflat flange
 with 5 SMA 905 fiber connectors

Discussion to decide
 2 x 5-fiber-feedthrough, or
 1 x 10-fiber-feedthrough

Next Steps

- Procure and fabricate components of the UV-light calibration system
 - Ten calibration channels (5 diffusers at each CPA side)
 - External and Internal fibers
 - Fiber feed-through
 - Diffusers at CPA
- Develop protoDUNE Calibration Plan with PD, Calibration, Monitoring groups
- Components of the calibration plan
 - Initial “Dry” Run
 - Initial LAr Run to verify functionality of PD channels
 - set SiPM gains
 - Periodic runs to monitor stability of the system
 - relative performance of PD channels
 - time resolution

Schedule of Activities at CERN

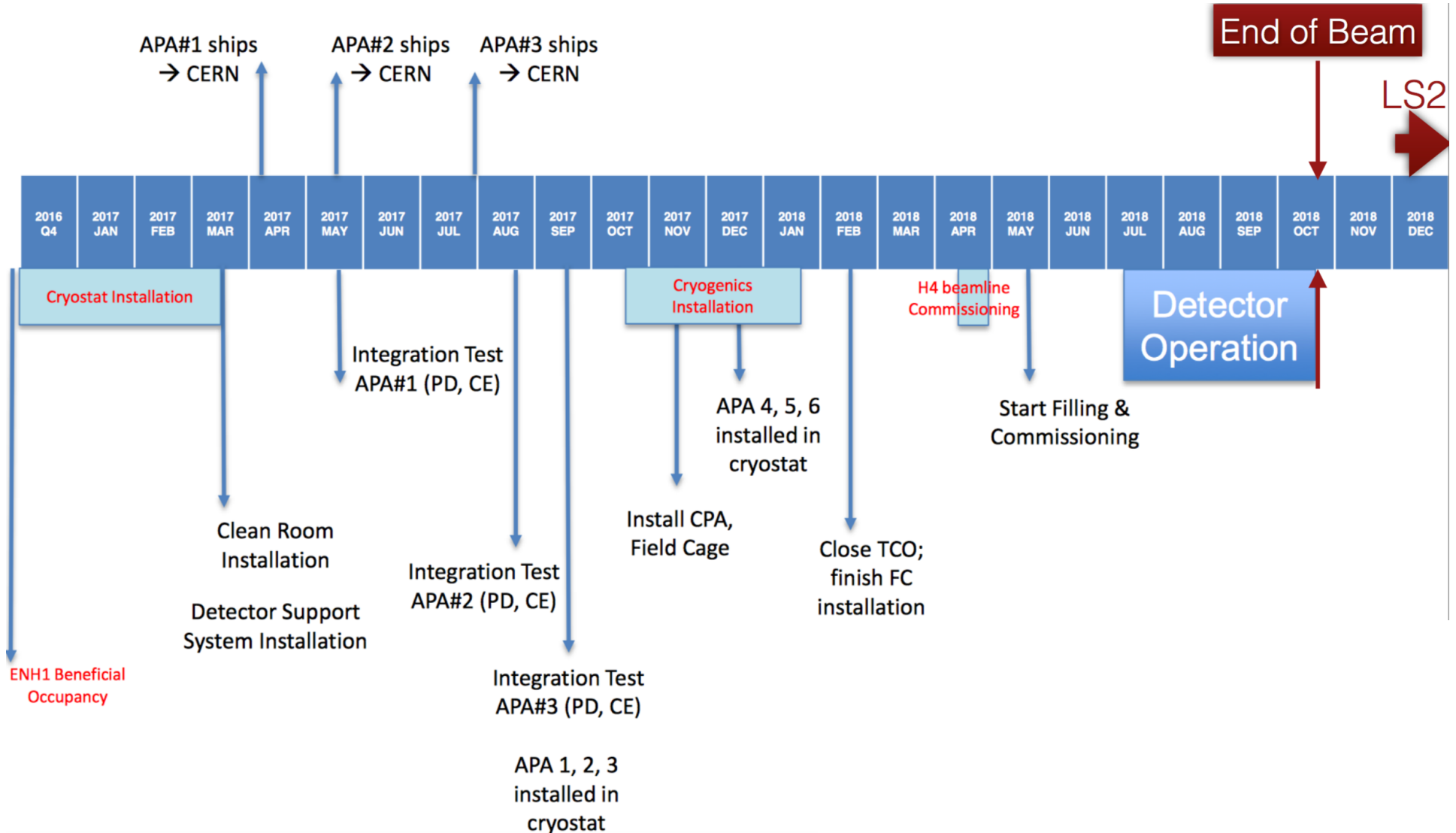

- Schedule of activities at CERN has been developed
- PD calibration installation activities start with CPA installation at CERN in October 2017.

Summary

- UV Light Calibration system designed for protoDUNE detector.
- Diffuse light from CPA to photo-detectors at APA.
- Prototype calibration module and fiber distribution systems built, tested, and operated in 35-ton detector
- The system is being re-designed for protoDUNE
 - Large time and amplitude dynamic range with good uniformity
- Development will be continued toward 10 kt DUNE.
 - Next Step: protoDUNE Calibration
- The calibration plan under developed with calibration and monitoring groups

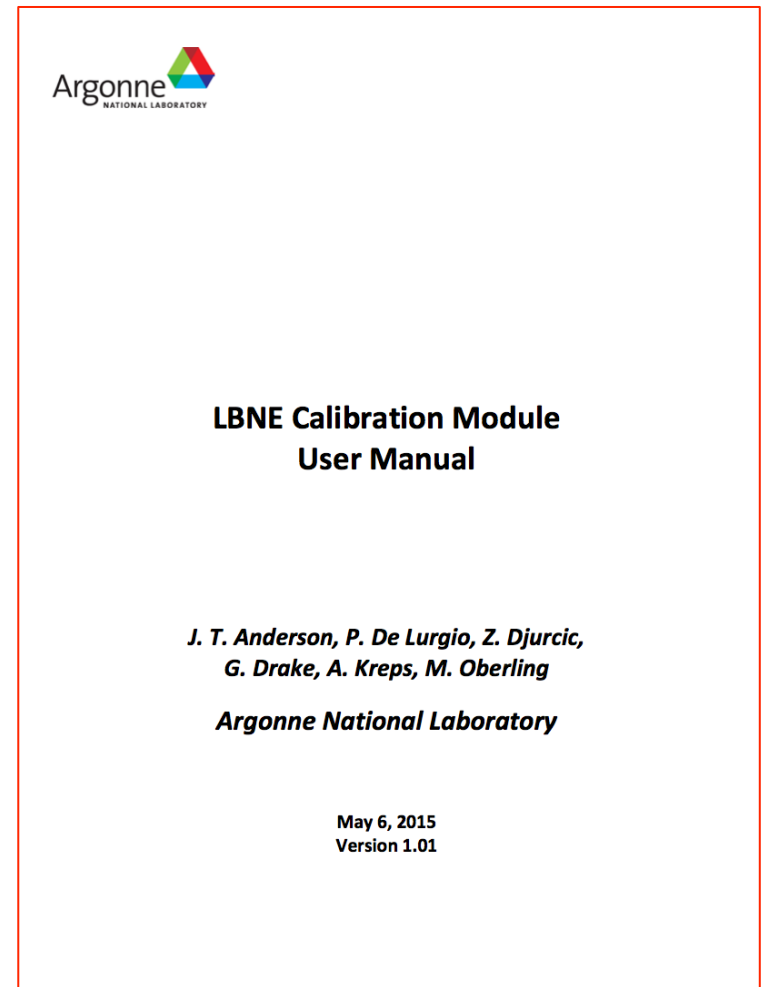

LBNE docdb-10842

Backups

Components of the PD UV Calibration System

- Components installed with 35t DUNE prototype

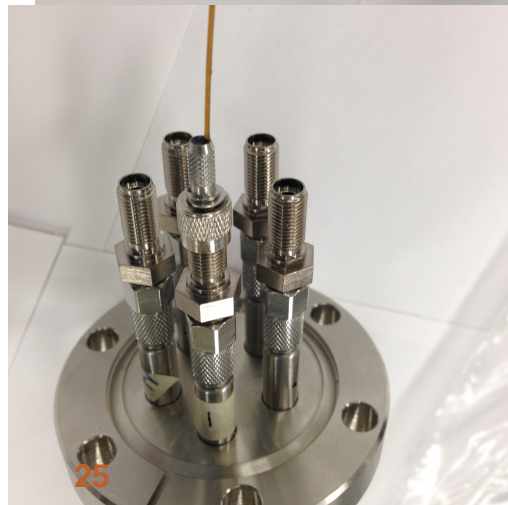
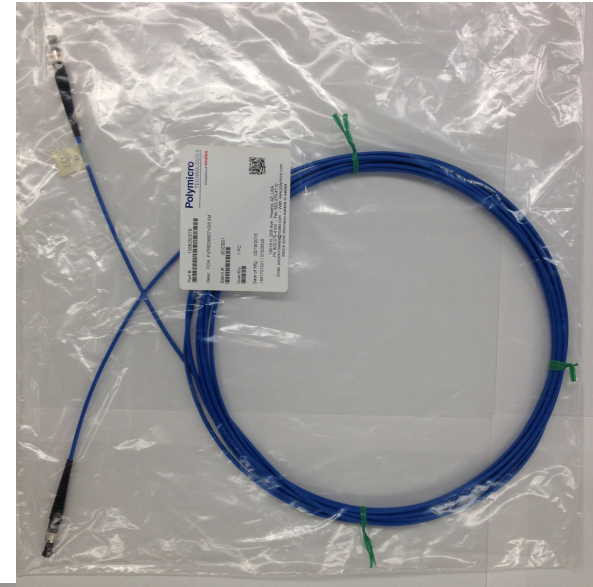
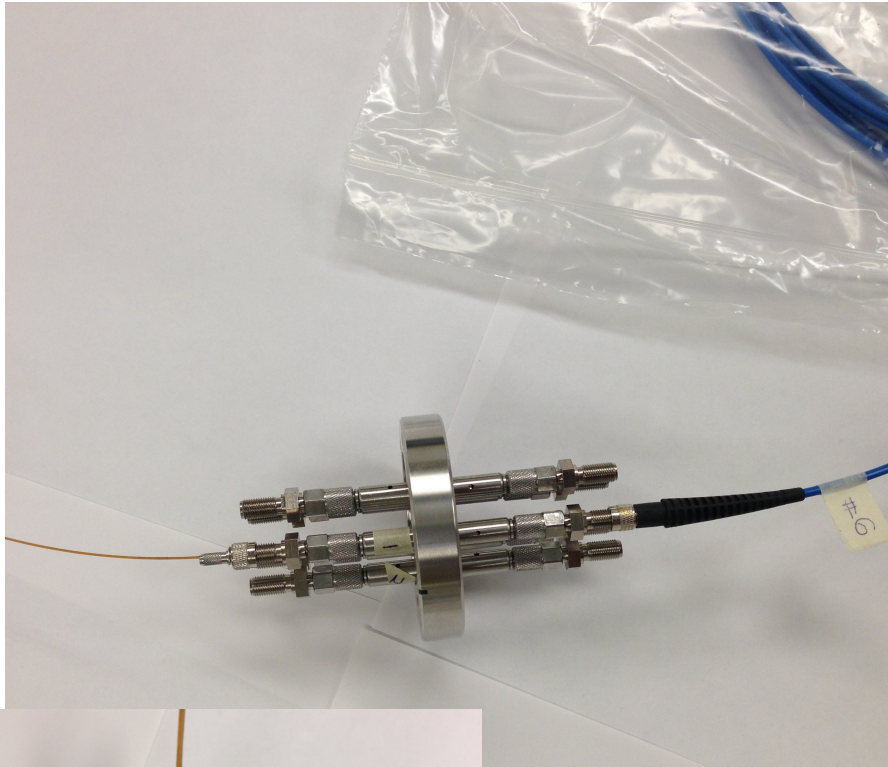

Components of the PD UV Calibration System

- Components installed with 35t DUNE prototype

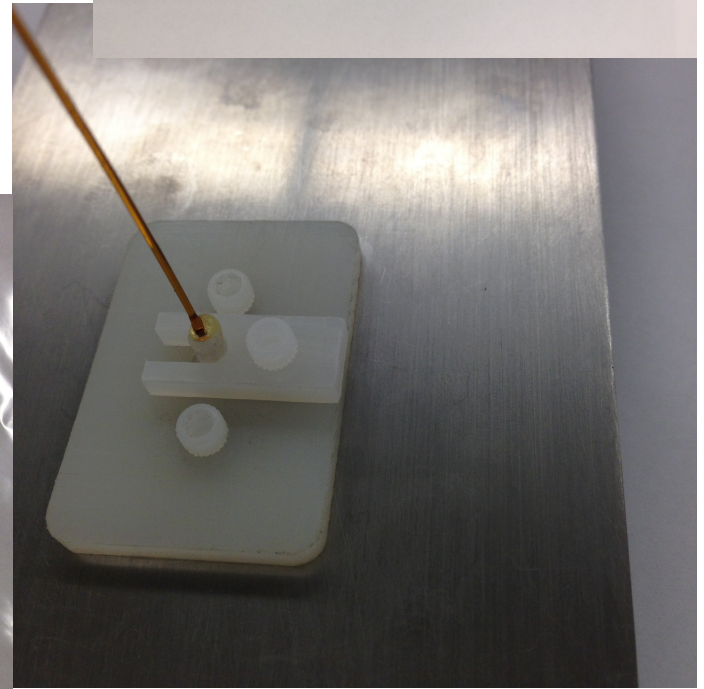
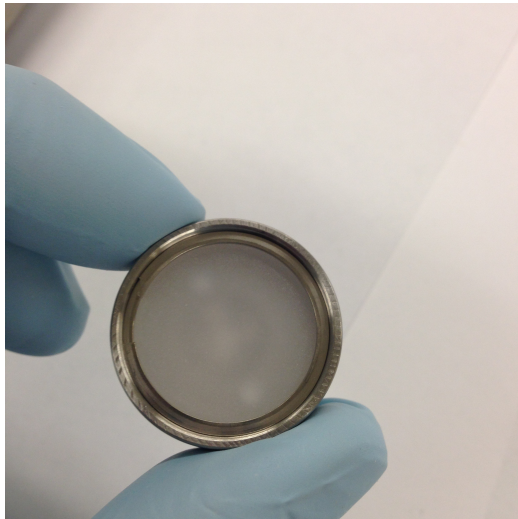
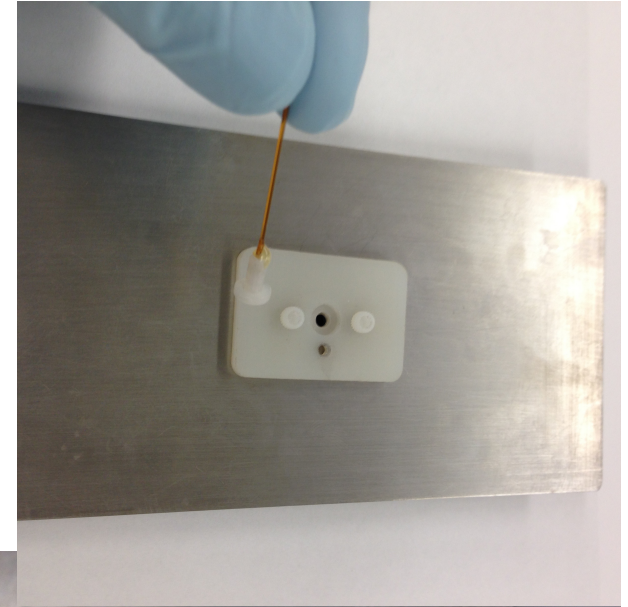
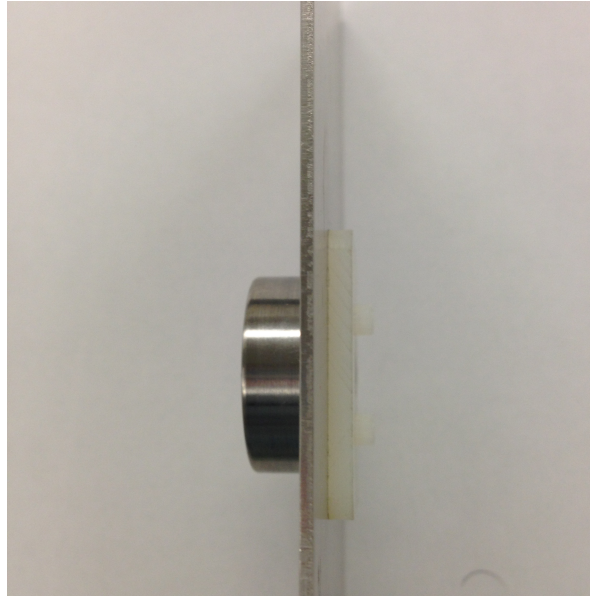
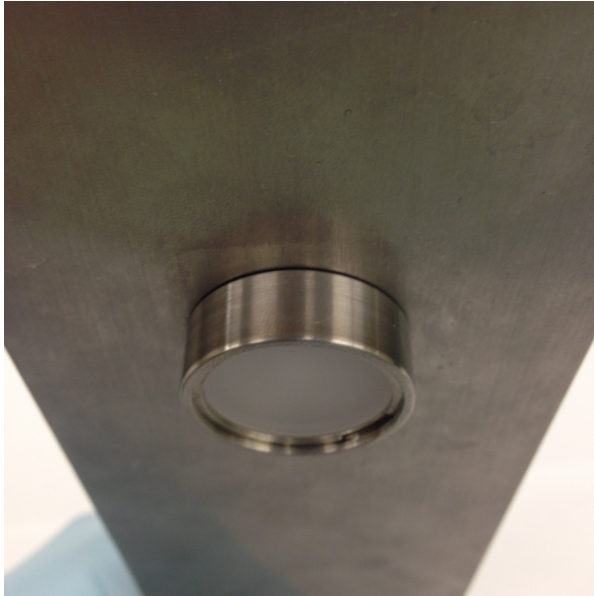

Components of the PD UV Calibration System

- Components installed with 35t DUNE prototype

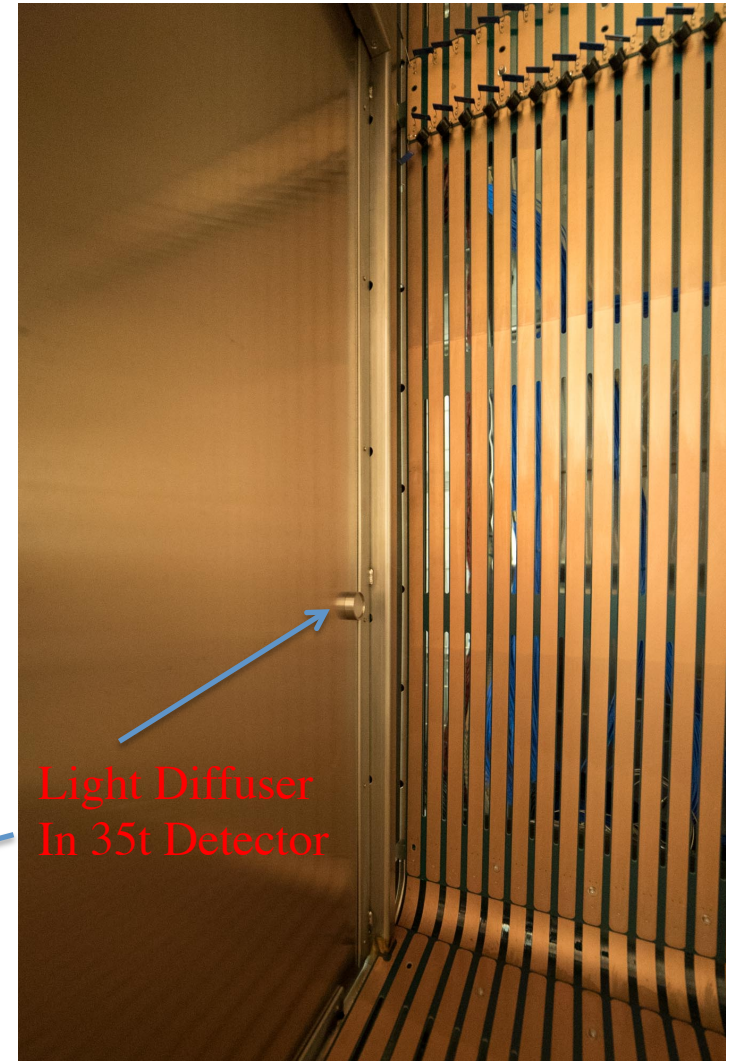
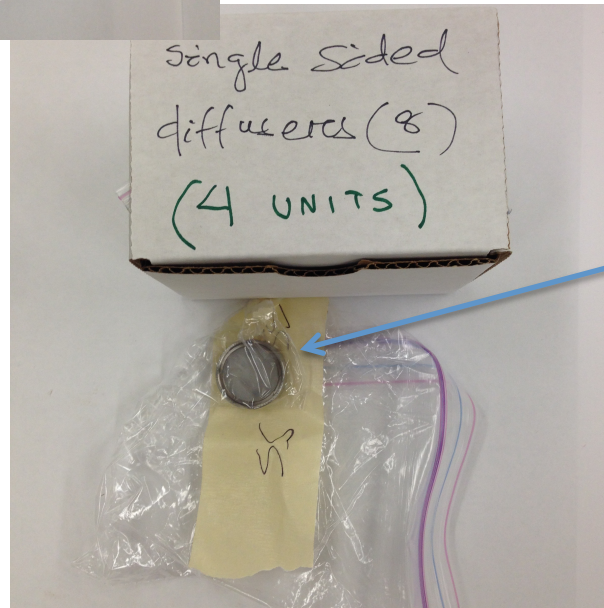
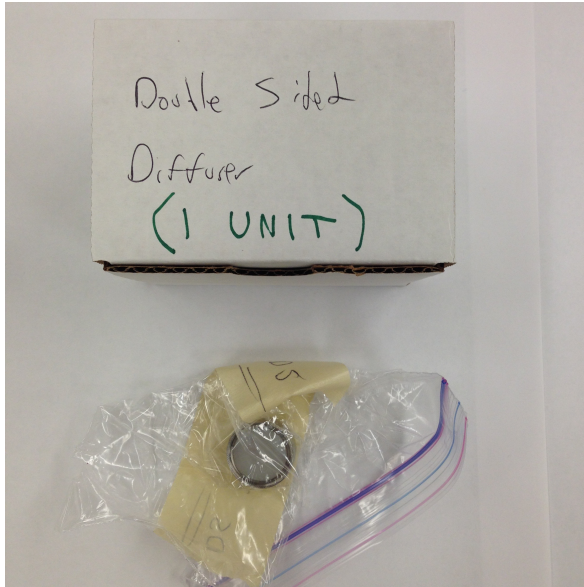

DUNE Calibration Module

Calibration Board

SSP mainboard

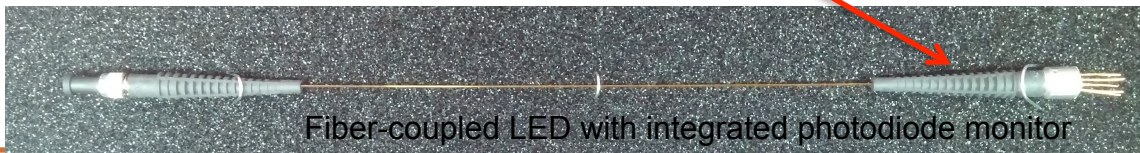
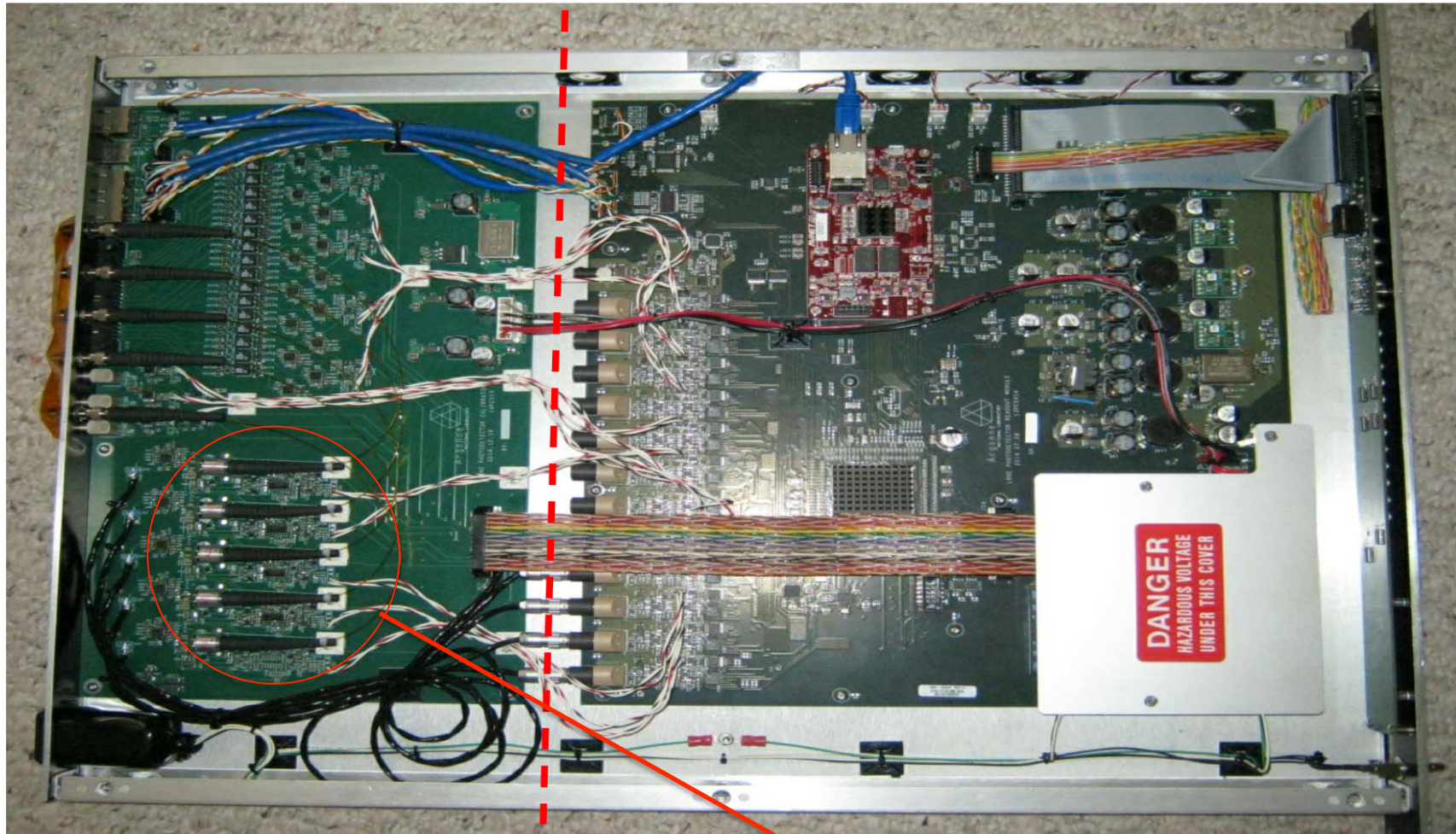

Fiber-coupled LED with integrated photodiode monitor

Expected Light Profile

- Simulated light distributions of at the APA location for the cases of the VUV light emitted by either
 - central diffuser only (left figure), or
 - outer four diffusers simultaneously (right figure).
- The simulation estimate has been obtained for 35-ton detector and scaled to 3.6 m CPA - APA distance at protoDUNE.

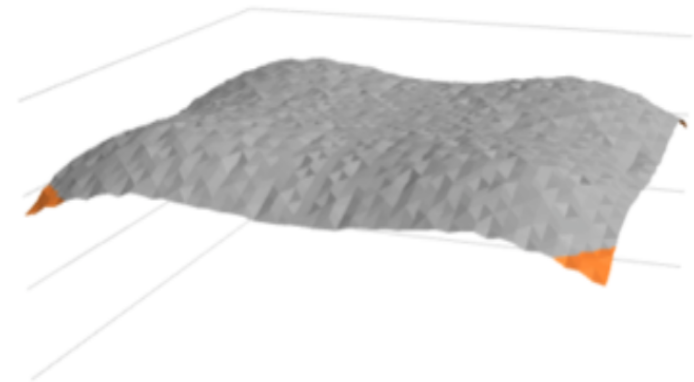
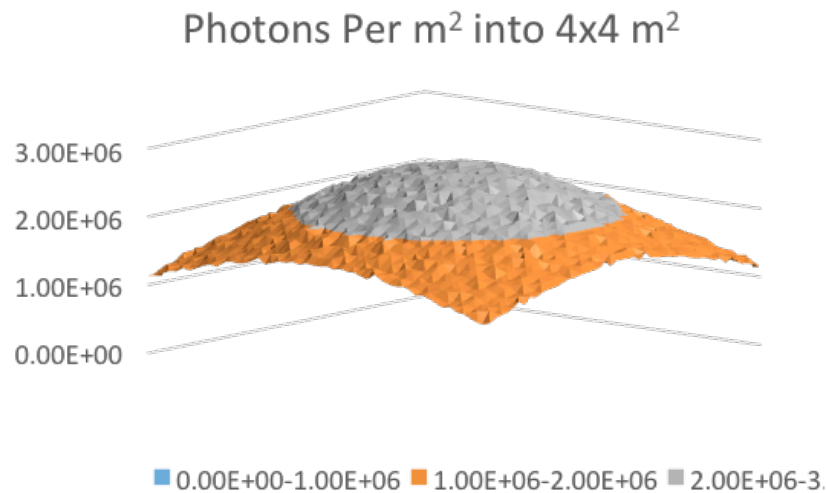

Reflective mirror for CPA diffuser



GO Edmund
optics | worldwide

TECHSPEC[®] 10 x 10mm UV Enhanced Aluminum, λ/4 Mirror

Stock No. #45-723

\$42.00

1 - 5 for \$42.00 each.

6 - 25 for \$34.00 each.

Specifications

Dimensions (mm)	10.0 x 10.0
Dimensional Tolerance (mm)	±0.25
Clear Aperture (%)	85
Thickness (mm)	2.0
Thickness Tolerance (mm)	±0.25
Surface Flatness	λ/4
Surface Quality	60-40
Edges	Ground, 0.75 mm Maximum Full Width Bevel
Substrate	BOROFLOAT®
Coating Specification	R _{a v g} >85% @ 250 - 700nm
Typical Energy Density Limit	0.5 J/cm ² @ 355nm, 10ns
Wavelength Range (nm)	250 - 700
Wavelength Range (μm)	0.25 - 0.7
Type	Flat Mirror
Coating	UV Enhanced Aluminum
RoHS	C

10-fiber feed-through quote

- Being developed with Gulf Photonics (ANL specs)



Quality Fiber Optic Solutions

Gulf Photonics, Inc.
640 Brooker Creek Blvd.
Suite 460
Oldsmar, FL 34677
United States

Invoice and shipping address:

Argonne National Laboratory
9700 S. Cass Avenue
B109
Lemont, IL 60439
United States
630.252.2000

Argonne National Laboratory
9700 S. Cass Avenue
B109
Lemont, IL 60439
United States

Quotation N° SO718

Your Reference:
RFQ 02 MAR 2016

Quotation Date:
03/02/2016 15:30:38

Salesperson:
Craig Vogeley

Payment Term:
Net 30

Description	Taxes	Quantity	Unit Price	Price
[2580013] VFT,8"CF-Non Rotatable Unthreaded Flange, 10 x FDP600um fiber,SMA-905,Cryo Adhesive,Torr-Seal	Exempted Tax (Sale)	1.00 Unit(s)	1320.00	\$ 1320.00
Total Without Taxes				\$ 1320.00
Taxes				\$ 0.00
Total				\$ 1320.00

Shipping Terms: Ex Works
Estimated Lead Time: 5 weeks ARO + approved drawing
Thank you for the opportunity to provide this quotation!

DUNE Calibration Module

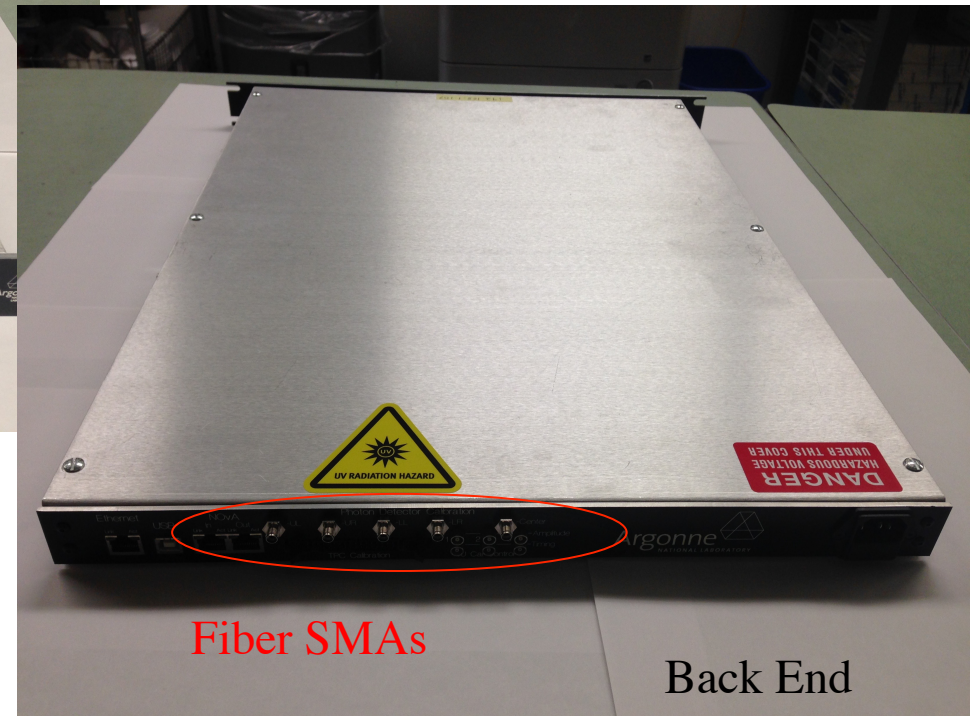
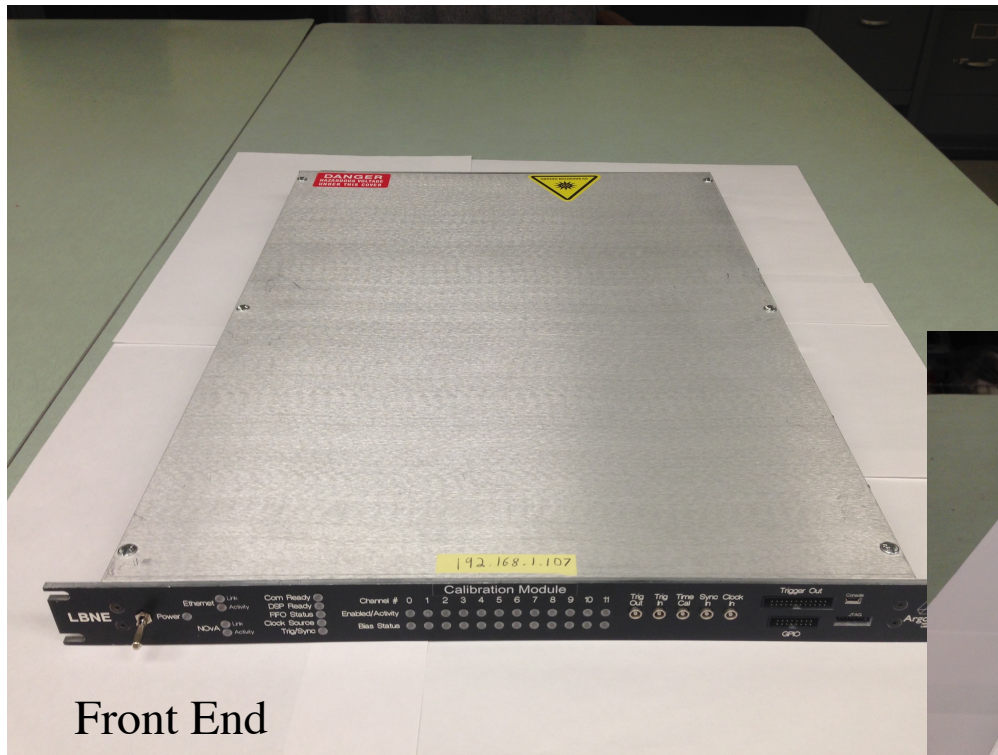

Nominal 10 kt Detector Design

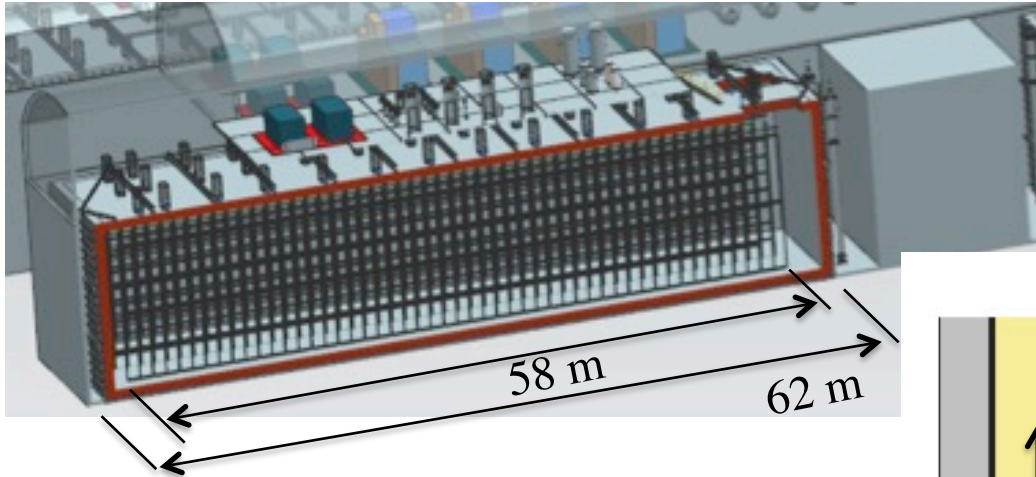

(slide from Jim Stewart)

Detector Module Characteristics

- 17.1/13.8/11.6 Total/Active/Fiducial mass
- 3 Anode Plane Assemblies (APA) wide
 - 3.6 m max drift length
- Cathode planes (CPA) are internal
- 58m long - 12m high - 14.4m active width

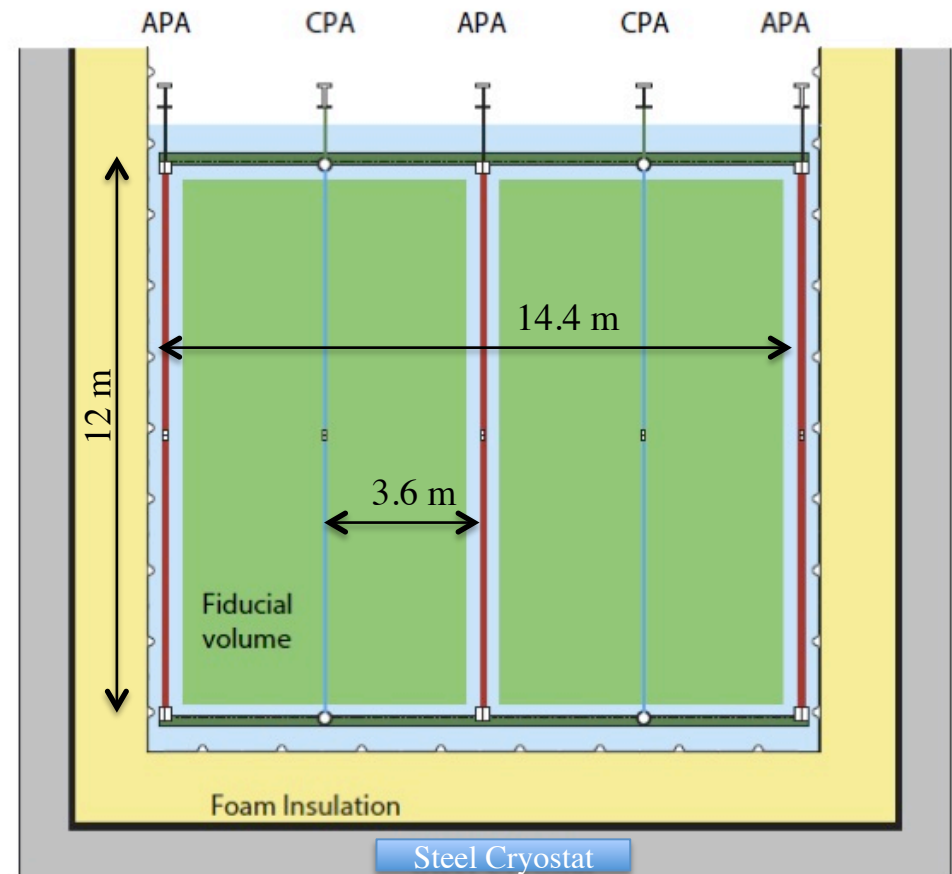

UV Light Calibration System in 10 kt DUNE detector

- Approach for DUNE 10 kton detector
 - install light diffusers at CPA
 - cover 4m x 4m APA area with a single diffuser

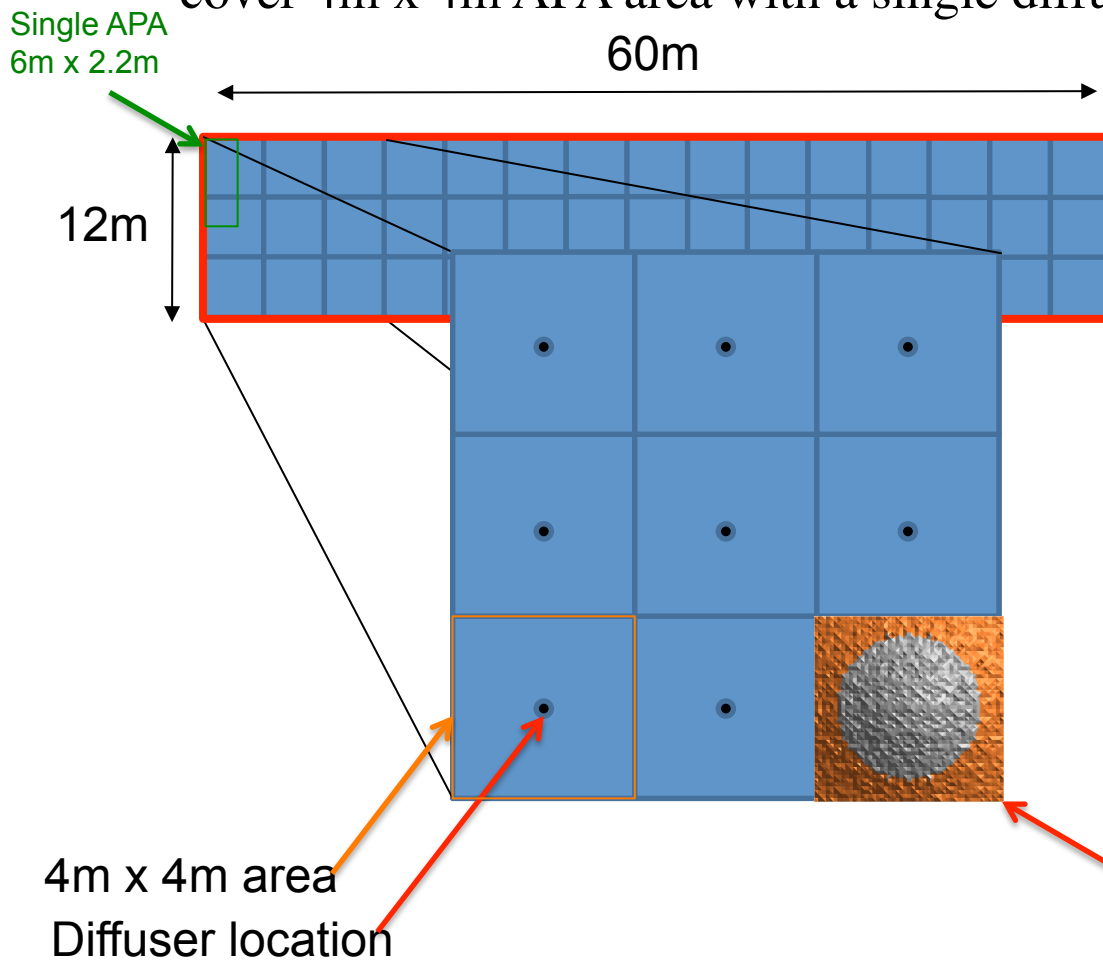

Photons Per m² into 4x4 m²

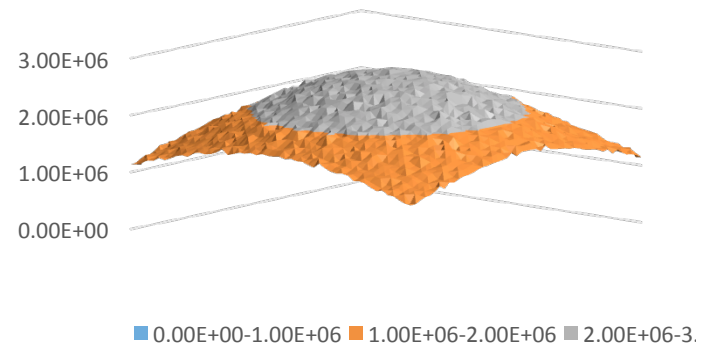

% STDEV	19%
Max	2.74E+06
Min	1.13E+06
Max/Min	2.425982
Average	1.96E+06

Simulated light response
at APA 4m x 4m area