

# Modifications and Improvements for LCLS-II ProdCMs

Tug Arkan on behalf of the Fermilab LCLS-II team

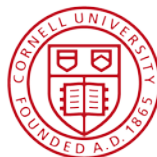

## 1.3 GHz Production Cryomodule, F10041183, 3D model

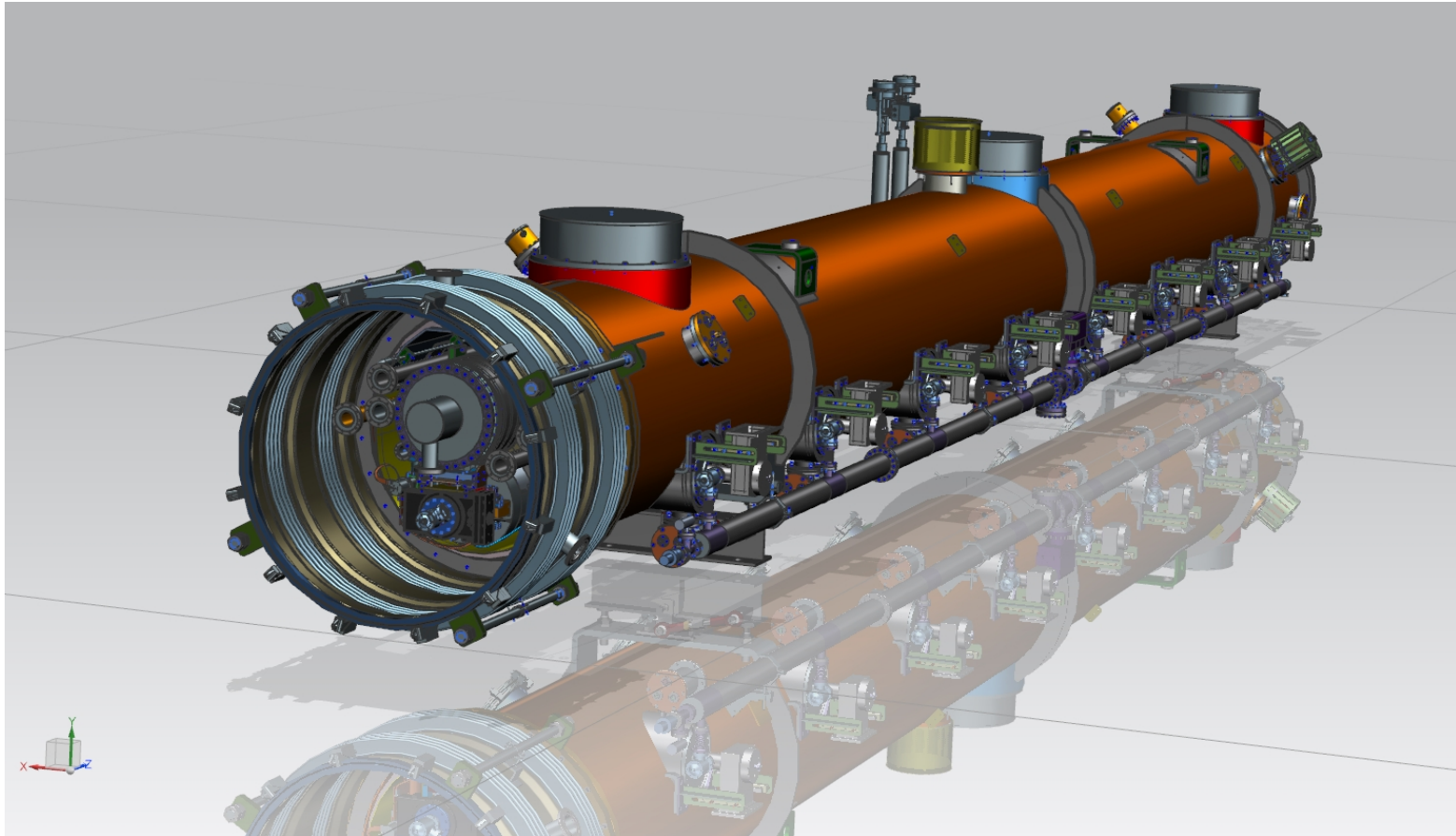

# Cavities

	<i>pCM</i>	<i>CM02</i>	<i>Production</i>
<b>Dressed Cavity</b>			
	AES cavities/Wah CHang material	RI cavities/Tokyo Den kai material	RI or EZ cavities/Tokyo Den kai or Ningxia material
	800C bake/160 micron EP @ FNAL	800C bake/140 micron EP @ vendor	900C bake/200 micron EP @ vendor
	short-short ILC R&D cavities	long-short XFEL style cavities	long-short XFEL style cavities
	Helium vessel dressing @ FNAL	Helium vessel welding @ vendor	Helium vessel welding @ vendor
	internal instrumentation in the helium tank for the cavities	no internal instrumentation (reduced scope)	no internal instrumentation (reduced scope)

# WS0 & WS1

	<i>pCM</i>	<i>CM02</i>	<i>Production</i>
<b>WS0 &amp; WS1</b>			
	CPI couplers (ILC design - modified), prepared and processed at SLAC	RI couplers (TTF3-modified), prepared at vendor, no processing	RI or CPI couplers (TTF3-modified), prepared at vendor, no processing
	String bellows and spools fabricated at Ameriflex & plated @ SLAC	String bellows and spools fabricated at Ameriflex & plated @ SLAC	String bellows and spools fabricated at Kurt Lesker & plated @ Nomura
	no pins are used between BPM and long magnet spool tube	no pins are used between BPM and long magnet spool tube	
	Long spool between upstream end gate valve and cavity#1 (short-short style)	Short spool is used because the cavity is long-short style.	
	Standard Particle free flange assembly/disassembly procedures were followed without any issues, concerns	Right angle valve orientation on the beampipe coupler end affected the particle free flange disassembly procedures negatively, this is a concern	Issue is resolved



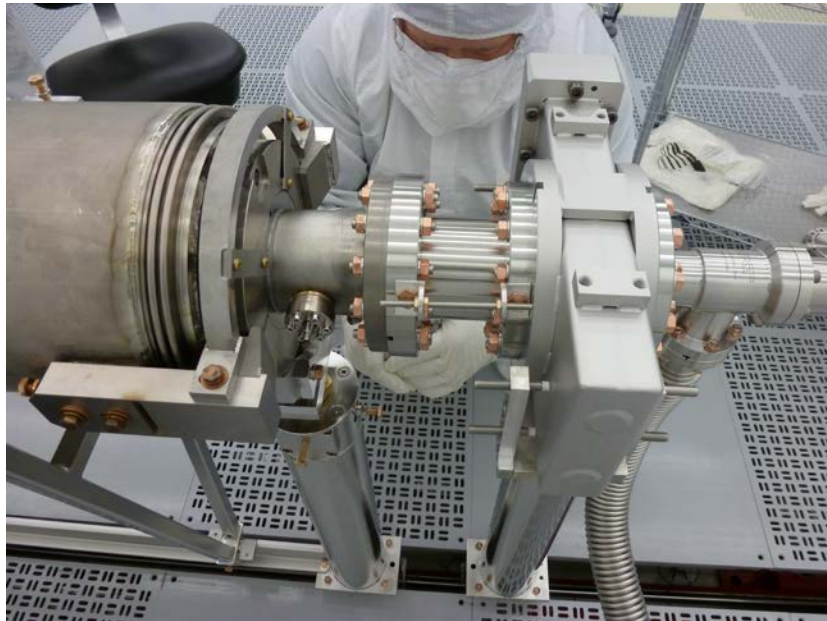

pCM configuration

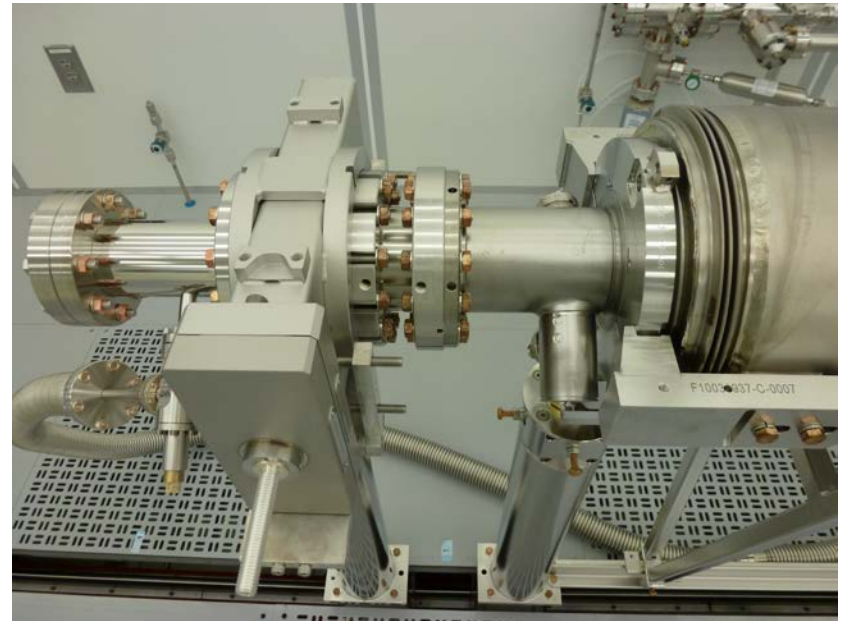

CM02 configuration

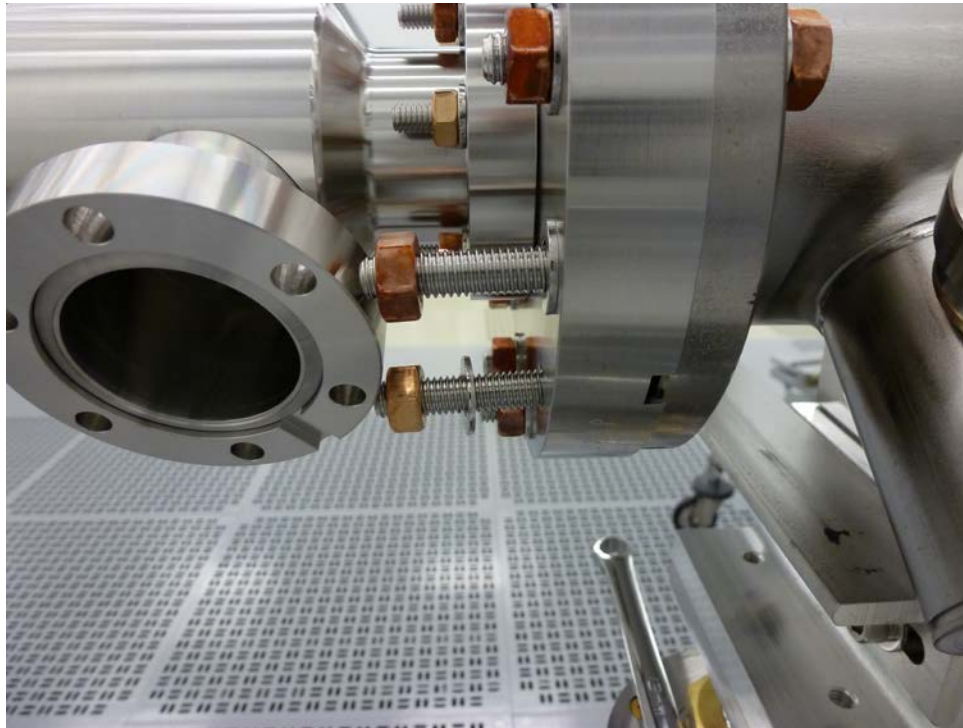

CM02 cavities FPC end beampipe flange right angle valve orientation caused deviation from standard PFFA assemblies. This is resolved for CM03 cavities.

# WS2

	<i>pCM</i>	<i>CM02</i>	<i>Production</i>
<b>WS2</b>			
	Cold Mass Upper (F10009954 was assembled in house after components were procured from various vendors	Cold Mass Upper is purchased fully assembled from WXCX, China. Using Loctite Type 242 for threaded connections on Cold Mass Upper (DWG F10009954-G)	Cold Mass Upper is purchased fully assembled from WXCX, China.
	Invar rod clamps were changed for pCM during the assembly. The clamps were optimized to work with double layer magnetic shielding but did not work during assembly. The design used is very similar to XFEL design	New Invar rod clamp for Cav#1 and Magnet for better support to react the vacuum forces when the string is under vacuum.	
	No baffle @ 2-phase line at JT injection point	Baffle @ 2-phase line at JT injection point	
	Needle bearings are all metal (aluminum housing and 316 SS needles)	Needle bearings are all metal (316 SS housing and needles)	Needle bearings are all metal (316 SS housing and needles)
	magnetic shielding had mechanical interfaces (specifically tuner range is reduced). This was due to increased tuner range after magnetic shielding end caps were fabricated	magnetic shielding design is optimized to eliminate mechanical interferences.	magnetic shielding design is optimized to eliminate mechanical interferences
	Cavity heaters attached with epoxy & string	Cavity heaters attached with epoxy & welded Ti wrap	Cavity heaters attached with epoxy & welded Ti wrap



Baffle



Ti wrap

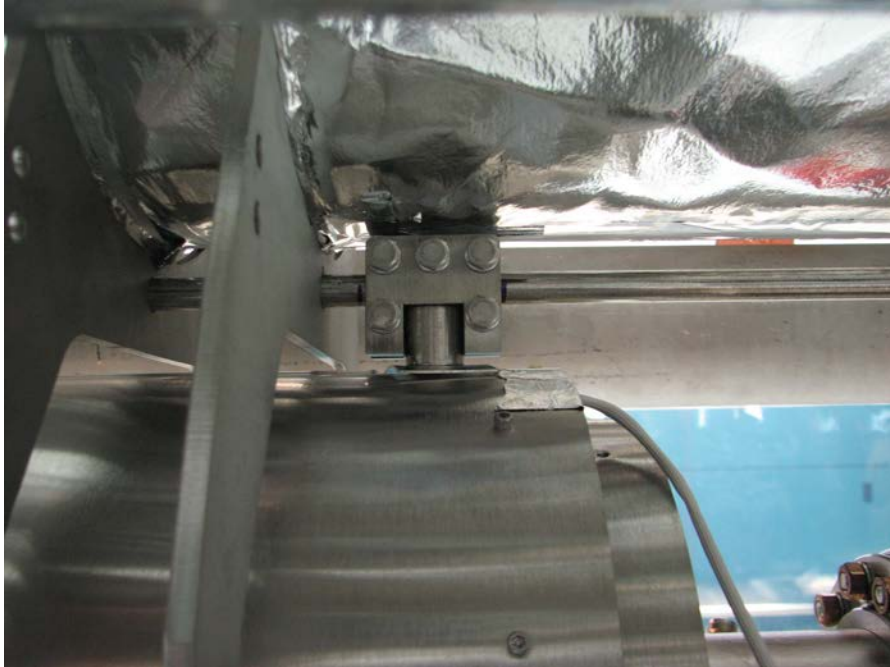

Standard cavity to invar rod clamp for pCM



Reinforced clamp design for Cav#1 and Magnet for ProdCMs



# WS3

	<i>pCM</i>	<i>CM02</i>	<i>Production</i>
<b>WS3</b>			
	50K coupler thermal strap tied to the lower aluminum heat shields	50K coupler thermal strap tied to return 50K pipe	50K coupler thermal strap tied to return 50K pipe
	Locking mechanism (such as Belleville washers) and indium foil for thermal intercept connections	Locking mechanism (such as Belleville washers) and indium foil for thermal intercept connections and specified torqueing of the fasteners	Locking mechanism (such as Belleville washers) and indium foil for thermal intercept connections and specified torqueing of the fasteners
	Tuner System: Split rings are custom fitted to the cavities	Tuner System: use modified split ring with set screws	Tuner System: use modified split ring with set screws
	Split quad current leads cooling flaps soldering is done manually without a fixture	Split quad current leads cooling flaps soldering is done manually using a fixture for better reliability and faster process	
	Split quad current leads length is long	Split quad current leads length is shortened based on the pCM test results	Split quad current leads length is shortened
	Magnetic shield end caps had some mechanical interferences.	design is optimized to eliminate all the interferences	design is optimized to eliminate all the interferences

50K thermal  
intercept

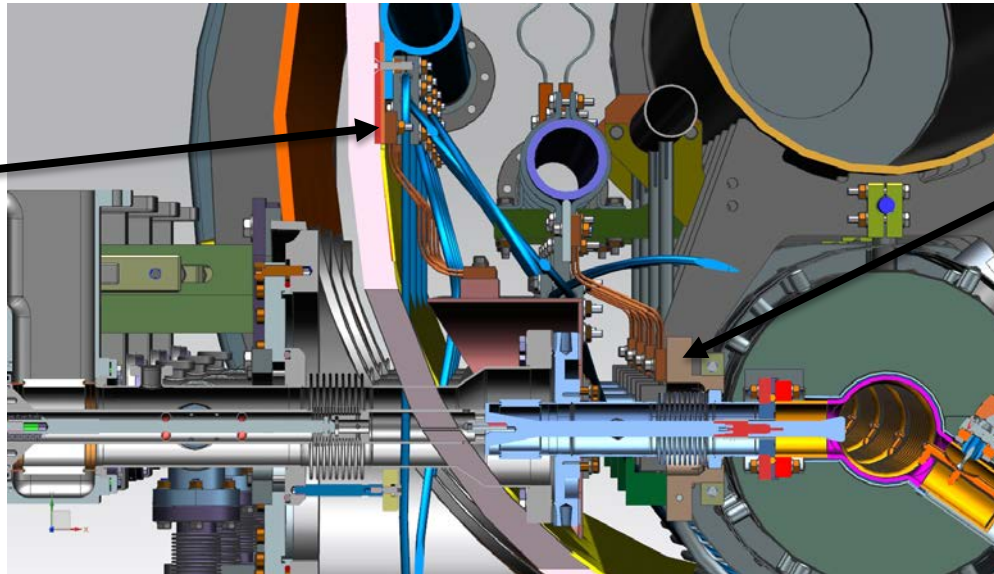

5K thermal  
Intercept

- Change in configuration for thermal connection from power couplers to 50K.
- 5K coupler intercept modified to hold vacuum forces.

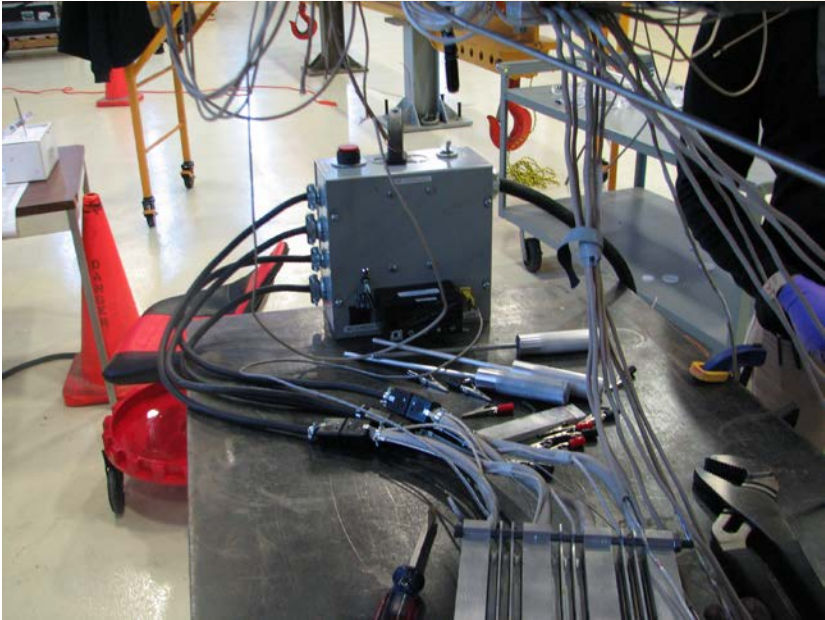

Split quad current leads cooling flaps soldering is done with a fixture to solder multiple leads simultaneously with an automated process for faster, more reliable and less risky procedure

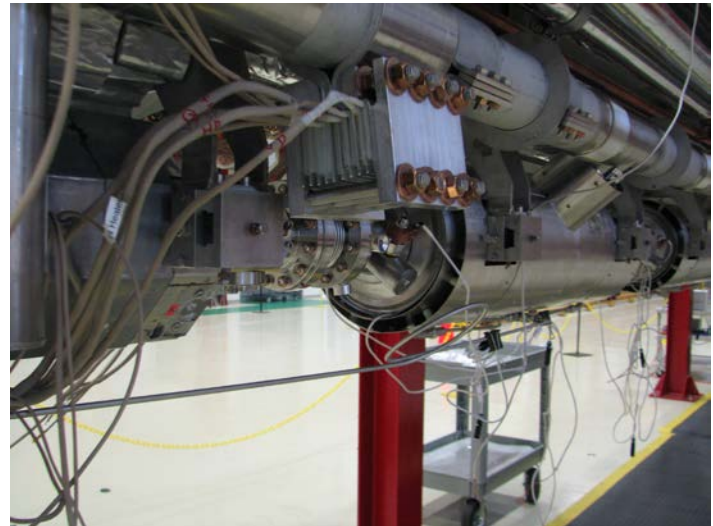



According to the latest calculations done and results from pCM:

- for 25 A the length of #18 copper leads between 5K and 50K intercepts shall be trimmed to 23" (was 34") and the length of #12 copper leads between 50K and 300K intercepts shall be trimmed to 20" (was 26.575")
  - if this length allows soldering leads to the 300K flange (20" might be too short for this), in this case we shall trim these leads as much as we can).
- The SC magnet leads soldered to the #12 copper wire between 2K and 5K shall be kept as long as possible to reduce the heat flow from 5K to 2K intercept (for pCM, we trimmed them by ~15").

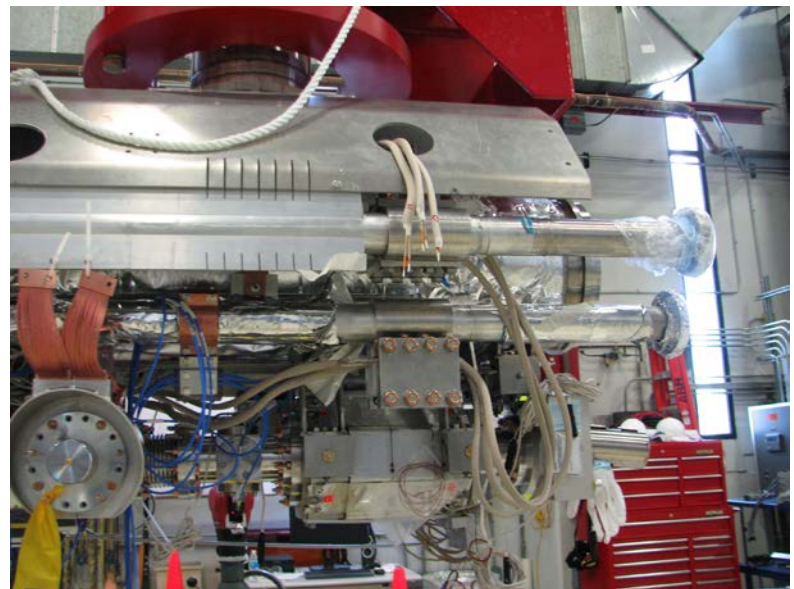
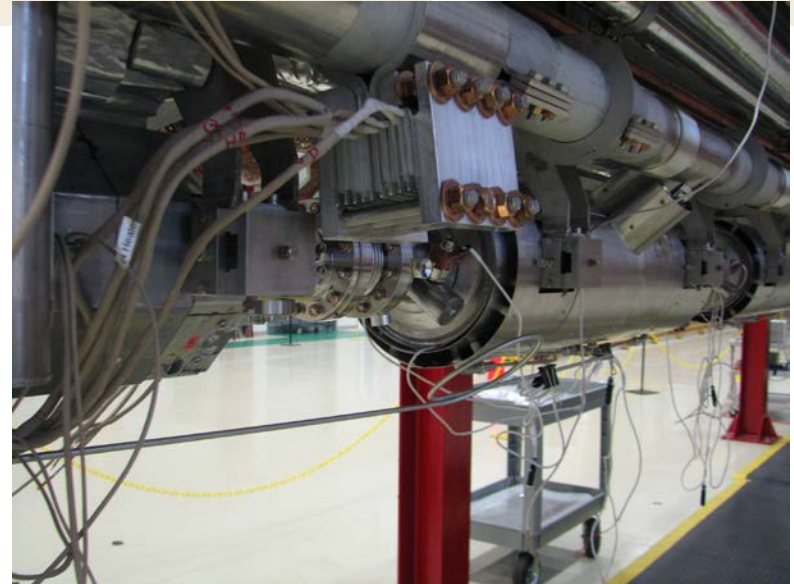

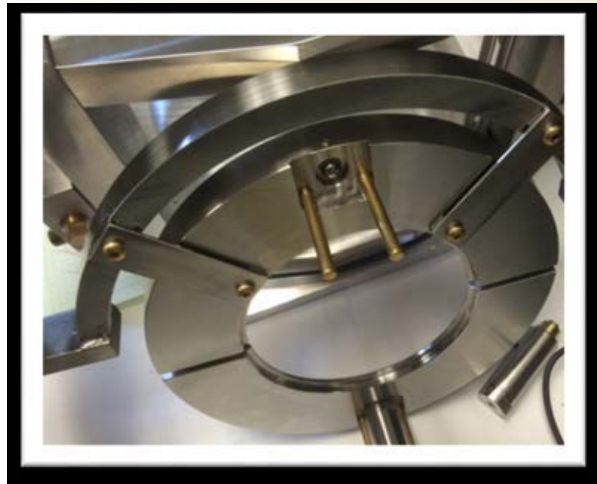

Split Ring need to be mount on the cavity between Nb alignment ring and NbTi conical flange close-fitting

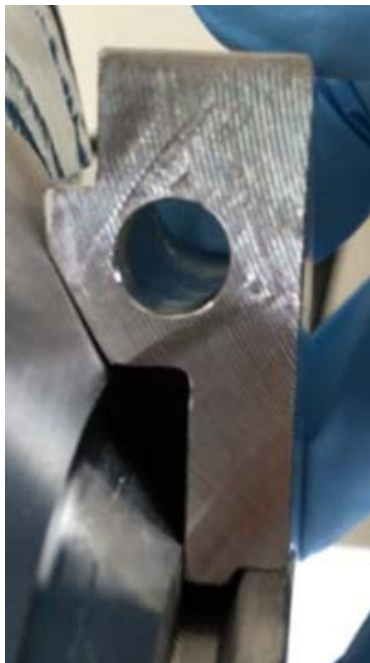

Modified split ring with set screws

# WS4

	<i>pCM</i>	<i>CM02</i>	<i>Production</i>
<b>WS4</b>			
	50K shields are made of Al 6061 material	50K shields are made of Al 1100 material	50K shields are made of Al 1100 material
	Homemade MLI blankets	Pre-made MLI blankets from a vendor	Pre-made MLI blankets from a vendor

# WS5

	<i>pCM</i>	<i>CM02</i>	<i>Production</i>
<b>WS5</b>			
	Cryogenic valves thermal intercept clamp is not brazed but mechanically installed	Cryogenic valves thermal intercept clamp is brazed	Cryogenic valves thermal intercept clamp is brazed
	Cryogenic valves 50K thermal shield box is welded to the cold mass heat shields	Cryogenic valves 50K thermal shield box is bolted to the cold mass heat shields	

Guard helium flange

Current lead cover

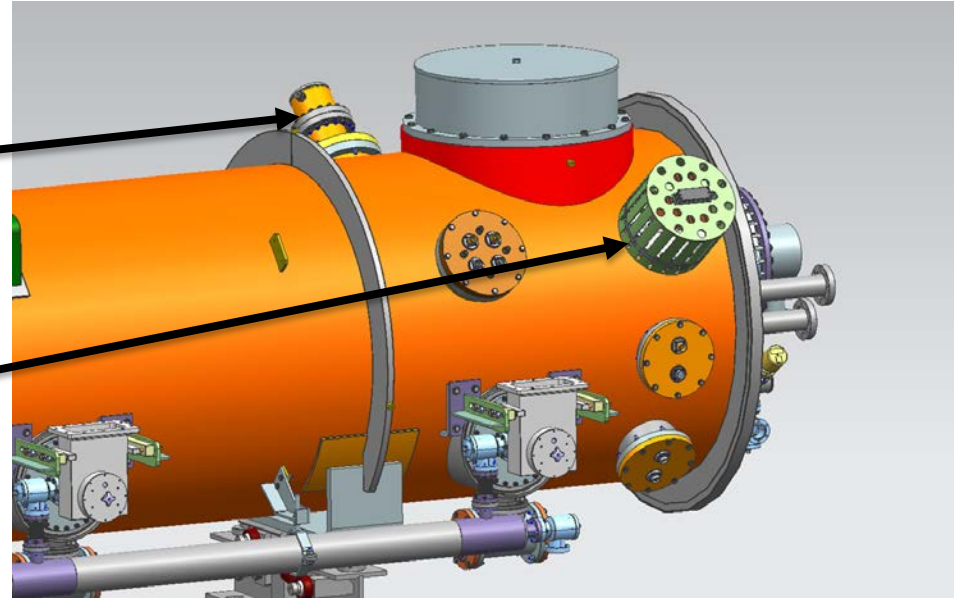

- Instrumentation flanges (reduced connectors, reduced size of guard helium flange)
- Magnet current lead flange cover for better protection of the fragile leads



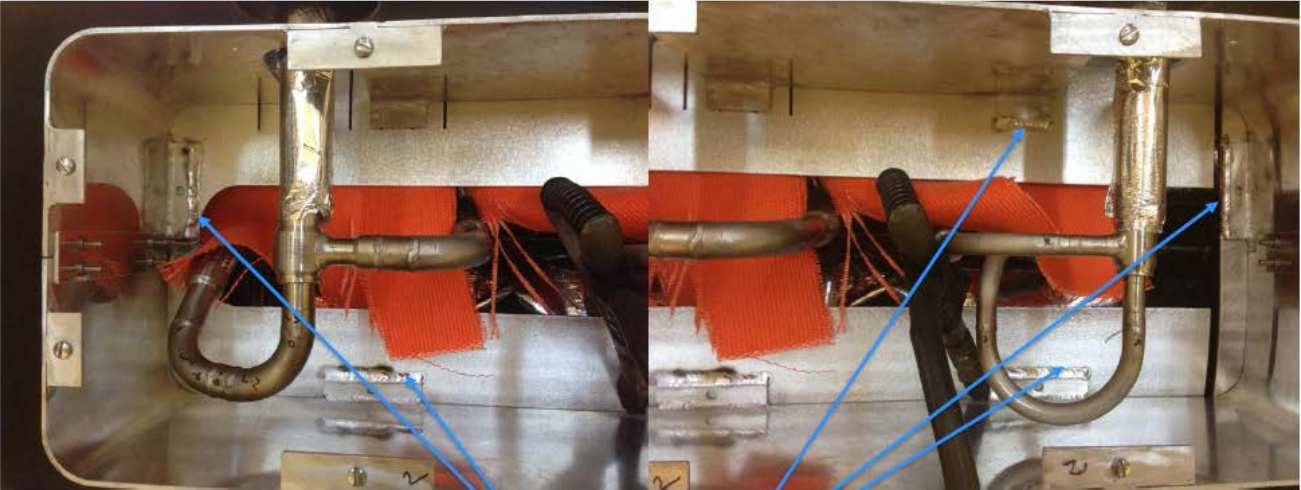
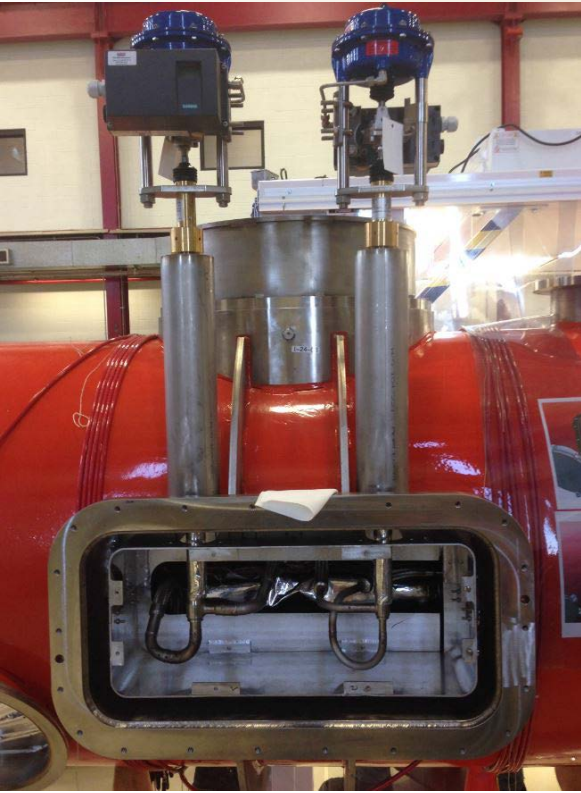

Tab Welds



30 Layers MLI

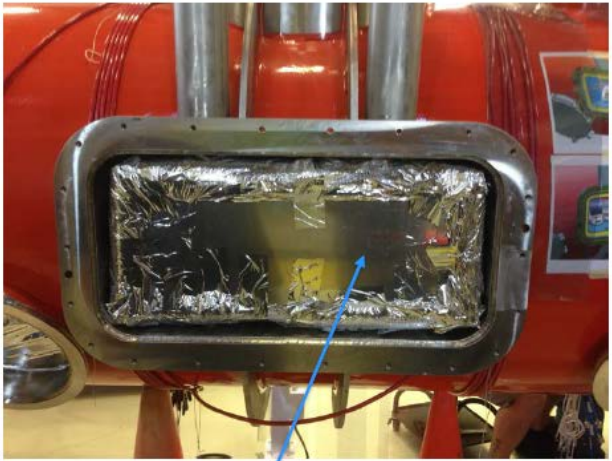

Shield Cover

# Instrumentation

---

- Reduced amount from pCM to ProdCMs
- For CM02, we have added back the 16 diode sensors for HOM bodies based on the current tests done on pCM. The end of the extended tests done on pCM shall be the decision point if we need to install these sensors for all ProdCMs.
- Helium vessel sensors on pCM is reading magnetic shielding temp. We believe that magnetic shielding is pressing to the helium vessel sensors through the 10 layers MLI. Starting from CM03, we will cut a hole of the MLI to stop the thermal path and also we are considering a G10 stand-off insulator to be installed on top of the diode sensors so it does not cross talk with the magnetic shielding.

Diode sensor  
on the HOM  
thermal  
intercept  
clamp

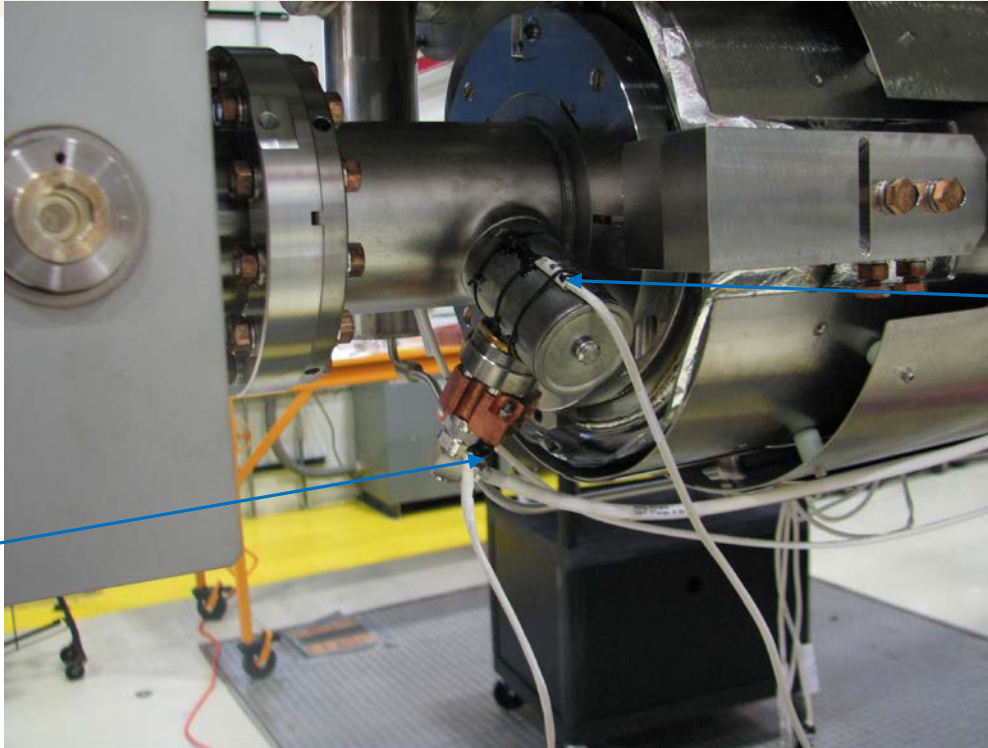

Diode sensor  
on the HOM  
can near the  
formteil welds

pCM and CM02 configuration. (Added  
scope for CM02)



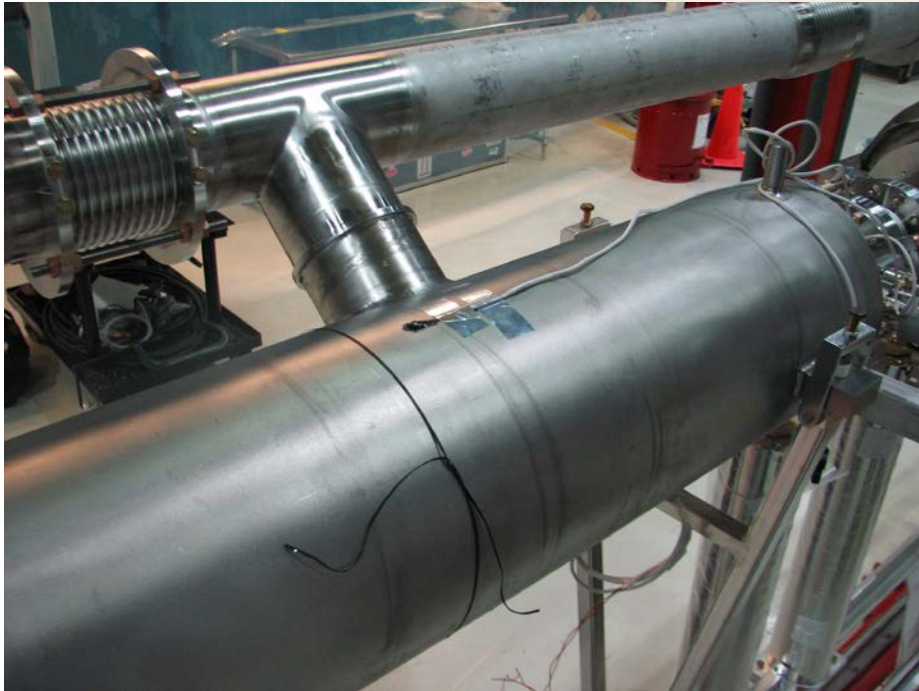

Helium Vessel Diode Sensor (top & bottom)

- all 8 cavities for pCM
- Cav#1 and Cav#5 for ProdCM

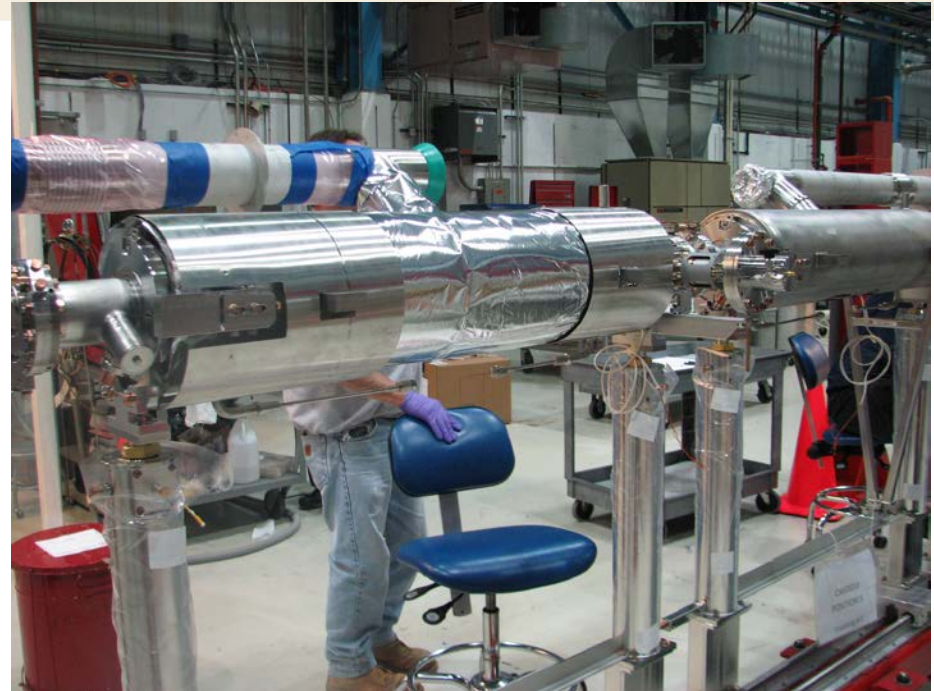

These diode sensors on pCM are reading magnetic shielding temp rather than helium vessel. Starting from CM03, thermal path between the installed sensor and magnetic shielding will be eliminated

# Vibration sensitive items mitigation on CM02

---

1. Support the capillary line from upstream end liquid level probe to cavity#1
2. Complete the assembly on the tuners and 2-phase pipe invar rods clamps and after the assembly resonance group will measure and if needed we will add G-10 supports around the 2-phase for these long invar rods.
3. Design group started to work on the design and drawings for a larger diameter JT fill line. CM assembly started to think about the least obstructive way to cut the current pipe and weld the larger diameter pipe.
4. Resonance group will continue to work with CMTS folks to further analyze the data from pCM and before we weld the lower heat shields, we will have another meeting to decide if we proceed with CM02 assembly or do further modifications based on the new results.
5. Setup a stand alone cavity under a cold mass upper at Cav#1 position. Assemble with upstream end gate valve and extra weight assembled top the gate valve to simulate BLA. Conduct vibration analysis tests.

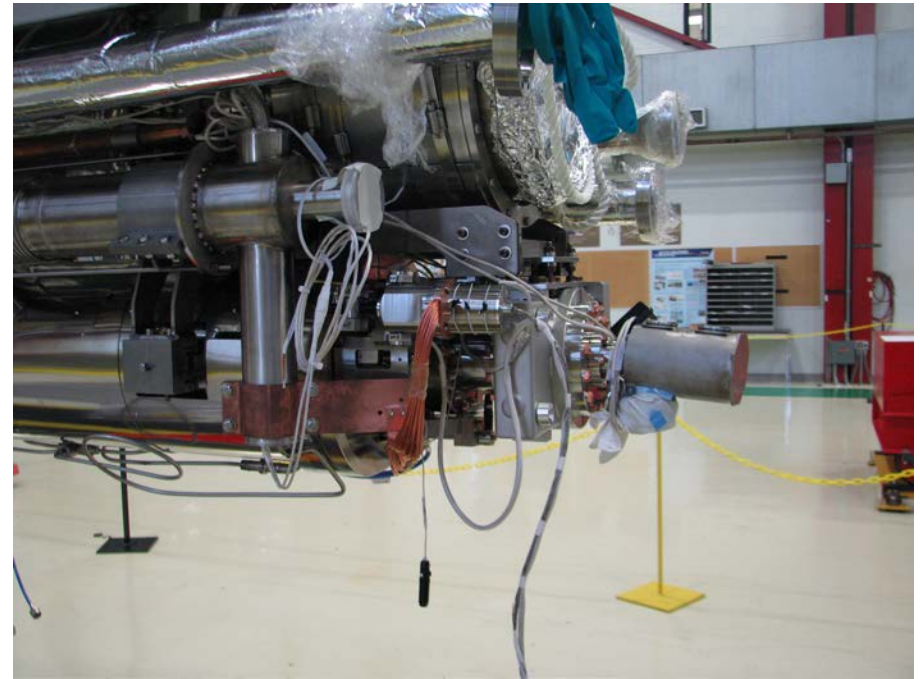
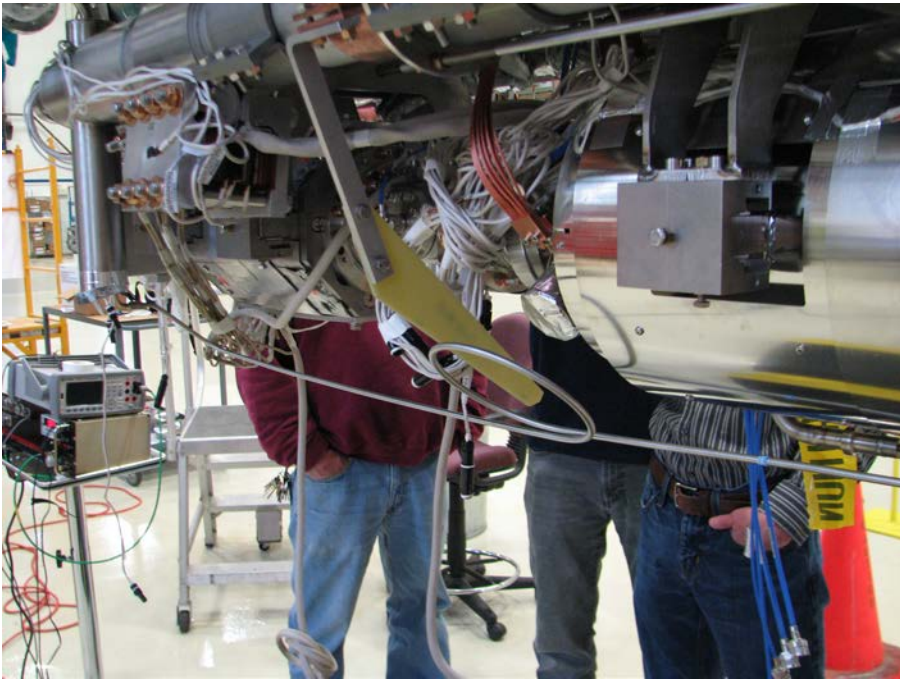

Downstream liquid level probe housing to Cav#8 capillary line is supported in pCM and CM02. For CM02, install similar support between Cav#1 and upstream liquid level probe housing



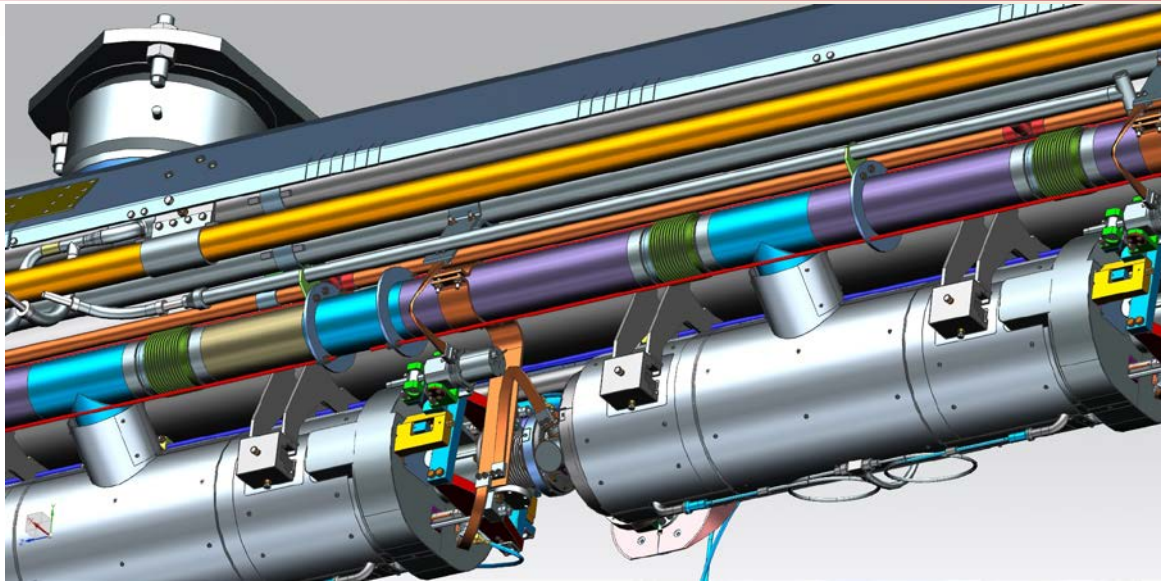

This line size was just originally selected based on mechanical space constraints and a desire for flexibility. We were not concerned about pressure drop. Our main consideration for 2-phase flow management was separation of that inlet location from the exit to the 300 mm pipe, so as not to carry liquid up into the HGRP.



For CM02, we are planning to replace this line with a larger diameter from 0.5 to 1 inch

# FNAL Team Center numbers for important components of 1.3 GHz CM (Prototype & Production)

	LCLS-II, 1.3GHz pCM	LCLS-II, 1.3GHz Production CM
Cryomodule Assembly	F10009945	F10041183
Vacuum Vessel	<a href="#">F10026609</a>	<a href="#">F10026609</a>
Cold Mass Assembly	F10009950	F10041120
Assembly Cold Mass Upper	<a href="#">F10009954</a>	<a href="#">F10009954</a>
Assembly cavity String	F10009887	F10041166
Assembly 1.3GHz dressed Cavity	F10027807 (short-short)	F10041087 (short-long)
Assembly magnet package	<a href="#">F10009375</a>	<a href="#">F10009375</a>
Assembly lever tuner (FNAL)	<a href="#">F10008766</a>	<a href="#">F10008766</a>

# Backup Slides

---

# Cryomodule Labels

