

Field Cage

C. Cantini, A. Gendotti, L. Molina Bueno, S. Murphy, A. Rubbia, C. Regenfus, F. Sergiampietri

ETH zürich

01.02.2017

- Field Cage 2D Drawings Complete
- Drawing Uploaded on the indico
- Drawings dimensions in mm and in [inches]
- Drawings projection following US standard
- Sent to Victor Guarino → still checking

Field Cage_DP_2D Drawings Updates

VERSION	Date	Modifications
ProtoDune_DP_Field Cage 29_11_2016	29.11.2016	1st version
ProtoDune_DP_Field Cage 13_12_2016	13.12.2016	Draw. Nr: DP-FC-001
		Modified quantity Pos11
		Add Pos: 17-18-19 --> FC Corner Connection
		Add DETAIL G --> FC Corner Connection
ProtoDune_DP_Field Cage 31_01_2017	31.01.2016	Draw. Nr: DP-FC-012 --> Pos11
		Updated Quantity
		Draw Nr: DP-FC-018 / 019 / 020
ProtoDune_DP_Field Cage 31_01_2017	31.01.2016	3 Drawings more:
		All Drawings
		Main Unit mm --> Second unit inch [...]
ProtoDune_DP_Field Cage 31_01_2017	31.01.2016	Draw. Nr: DP-FC-007
		Cathode Fixing Plate --> Geometry changed
		Draw. Nr: DP-FC-010
ProtoDune_DP_Field Cage 31_01_2017	31.01.2016	Draw. Nr: DP-FC-011
		Cathode Blocking Plate --> Geometry changed
ProtoDune_DP_Field Cage 31_01_2017	31.01.2016	Plate Between Modules --> hole in center

Complete Field Cage

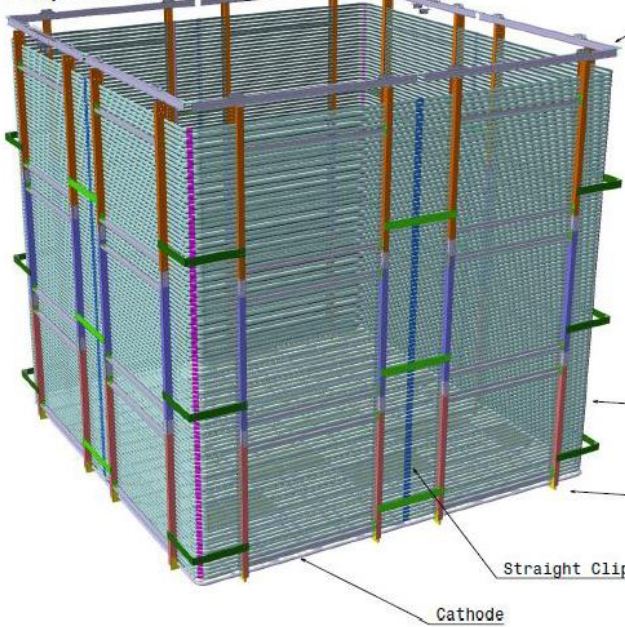

Stainless Steel Hanging System

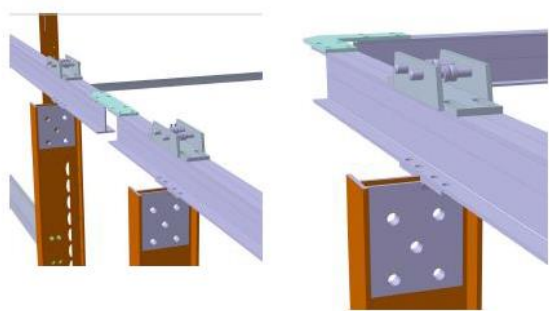

Corner 45 deg profile with straight clip

Cathode Hanging System

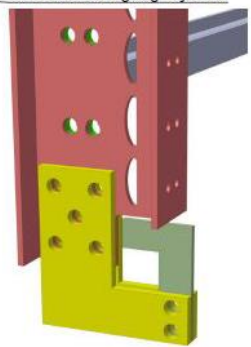

Straight Clip

Cathode

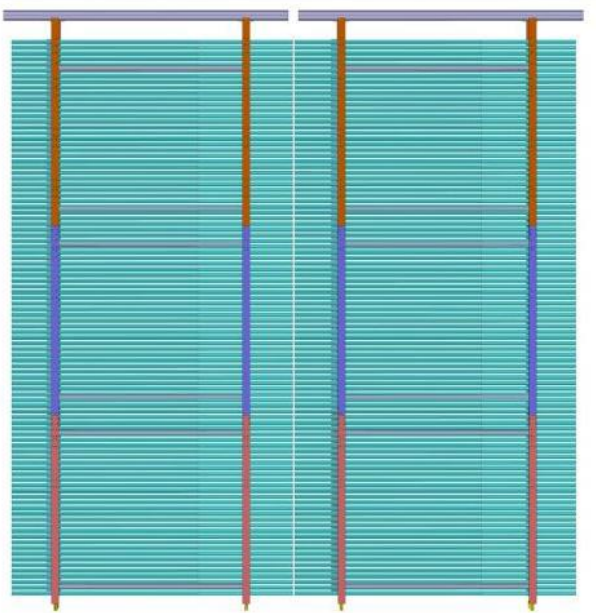

Full Module

Full Module Mirrored

Module is the Same.
Position of the Alu Profiles
and connection points to
SS I-Beam are Mirrored

Complete single Module

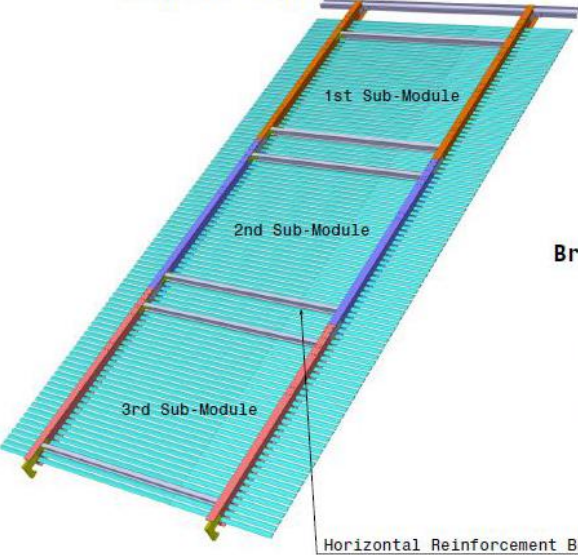

1st Sub-Module

2nd Sub-Module

3rd Sub-Module

Horizontal Reinforcement Brackets

Bracket and Main I-Beam Junction

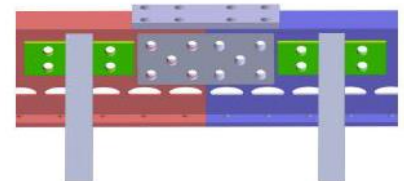

Cathode Exploded

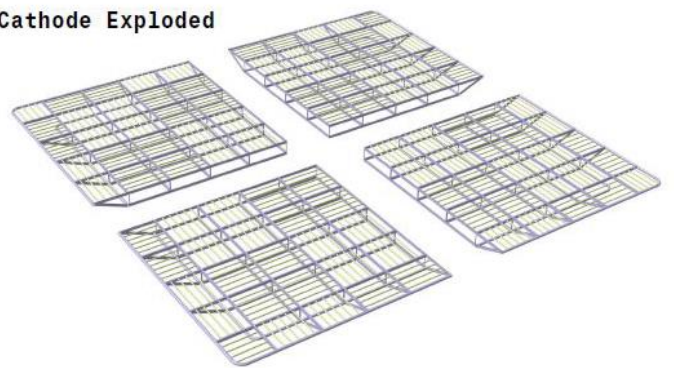

Project:	ETH Zürich	Scale:	1:1
Client:	ETH Zürich	Sheet:	1
Assembly:	Field Cage	Revision:	1
Author:	ETH Zürich	Created:	2018-08-10 10:00
Editor:	ETH Zürich	Modified:	2018-08-10 10:00
Checker:	ETH Zürich	Released:	2018-08-10 10:00
Approver:	ETH Zürich	Released:	2018-08-10 10:00
ETH zürich		Field Cage Overview	
		DP-FC-000	

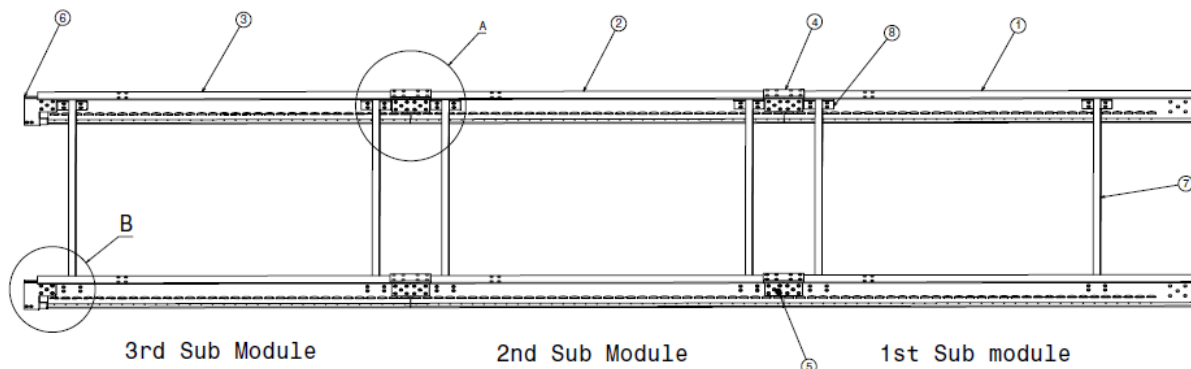
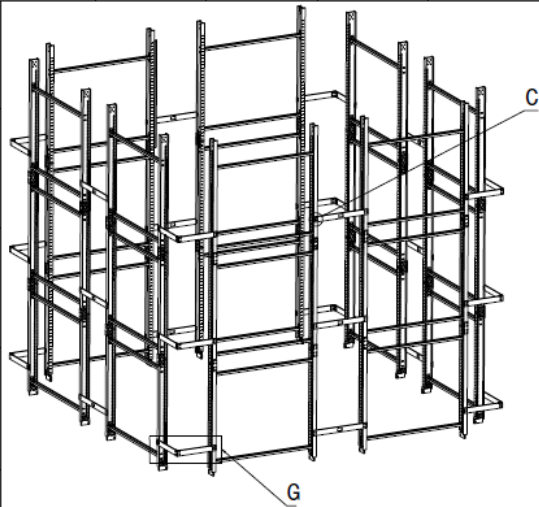

DETAIL C

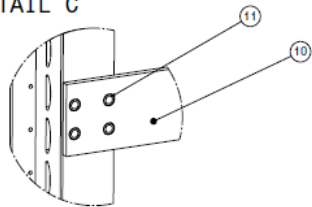

DETAIL G

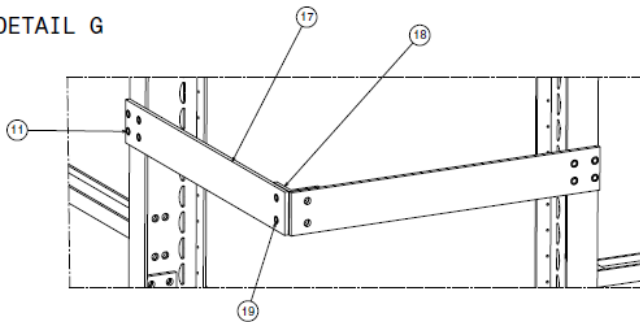

DETAIL B

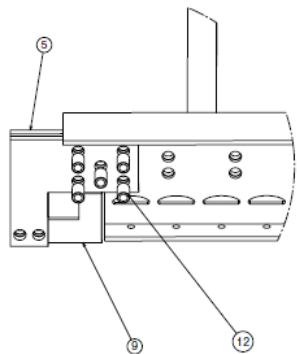

DETAIL A

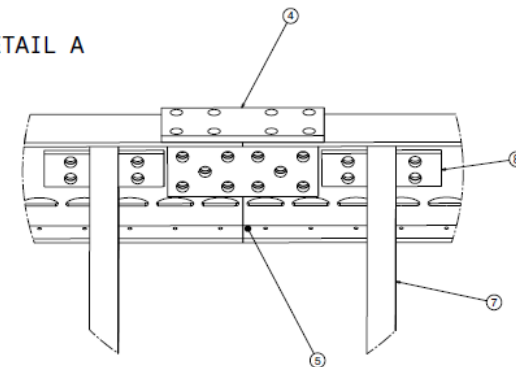

Pos	Part Name	Part Number	Material	Quantity	Description
1	1st Sub Module Main Beam	DP-FC-002	FRP	16	6 Inch I-Beam
2	2nd Sub Module Main Beam	DP-FC-003	FRP	16	6 Inch I-Beam
3	3rd Sub Module Main Beam	DP-FC-004	FRP	16	6 Inch I-Beam
4	Fixing Plate Sub Modules 1	DP-FC-005	G10/FR4	32	
5	Fixing Plate Sub Modules 2	DP-FC-006	G10/FR4	64	
6	Cathode Fixing Plate	DP-FC-007	G10/FR4	32	
7	Horizontal Beam	DP-FC-008	FRP	48	3 Inch I-Beam
8	Horizontal Beam L-Profile	DP-FC-009	FRP	192	3x3x1/4 Inch L
9	Cathode Blocking Plate	DP-FC-010	G10/FR4	16	
10	Plate Between Modules	DP-FC-011	G10/FR4	12	
11	Insert for Modules Plate	DP-FC-012	G10/FR4	192	
12	Insert for Cathode Connection	DP-FC-013	G10/FR4	112	
13	Insert Sub Modules 1	DP-FC-014	G10/FR4	256	
14	Insert Sub Modules 2	DP-FC-015	G10/FR4	320	
15	Insert for L Short	DP-FC-016	G10/FR4	384	
16	Insert for L Long	DP-FC-017	G10/FR4	192	
17	Plate for FC Corner	DP-FC-018	G10/FR4	24	
18	L-Profile for FC Corner	DP-FC-019	FRP	12	3x3x1/4 Inch L
19	Insert for FC Corner	DP-FC-020	G10/FR4	48	

Project	DP-FC	Scale	1:20
Client	ETH zürich	Sheet No.	20
Author	ETH zürich	Date	2018-08-01
Reviewer	ETH zürich	Version	1
Approver	ETH zürich	Drawn by	

ETH zürich Field Cage Modules Overview DP-FC-001

Thank you.....