

Technical Design Review of the Dual Phase ProtoDUNE

April 24-25, 2017

HV Feedthrough (HVFT)

C. Cantini, P. Chiu, A. Gendotti, L. Molina Bueno, S. Murphy, A. Rubbia,

C. Regenfus, F. Sergiampietri, S. Wu

CERN - ETHZ

High voltage system in a nutshell

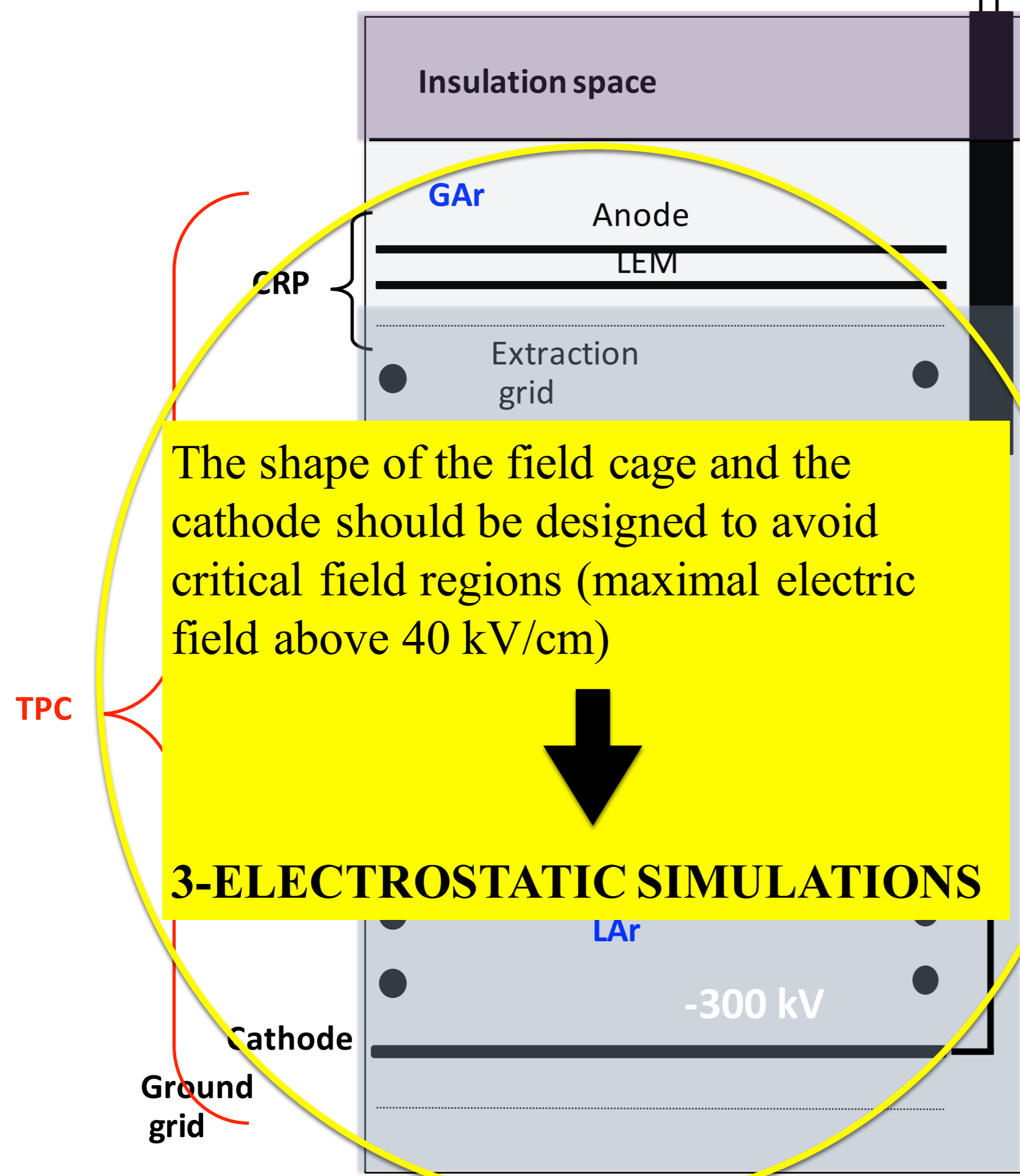

2-Transmission of the nominal voltage from the power supply to the cathode

High voltage feedthrough (HVFT)

High Voltage cable

Connection between the HVFT and the cathode

1-Generation of the nominal high voltage

100 kV Heinzinger power supply (PSU)

HVFT on the top of the cryostat.

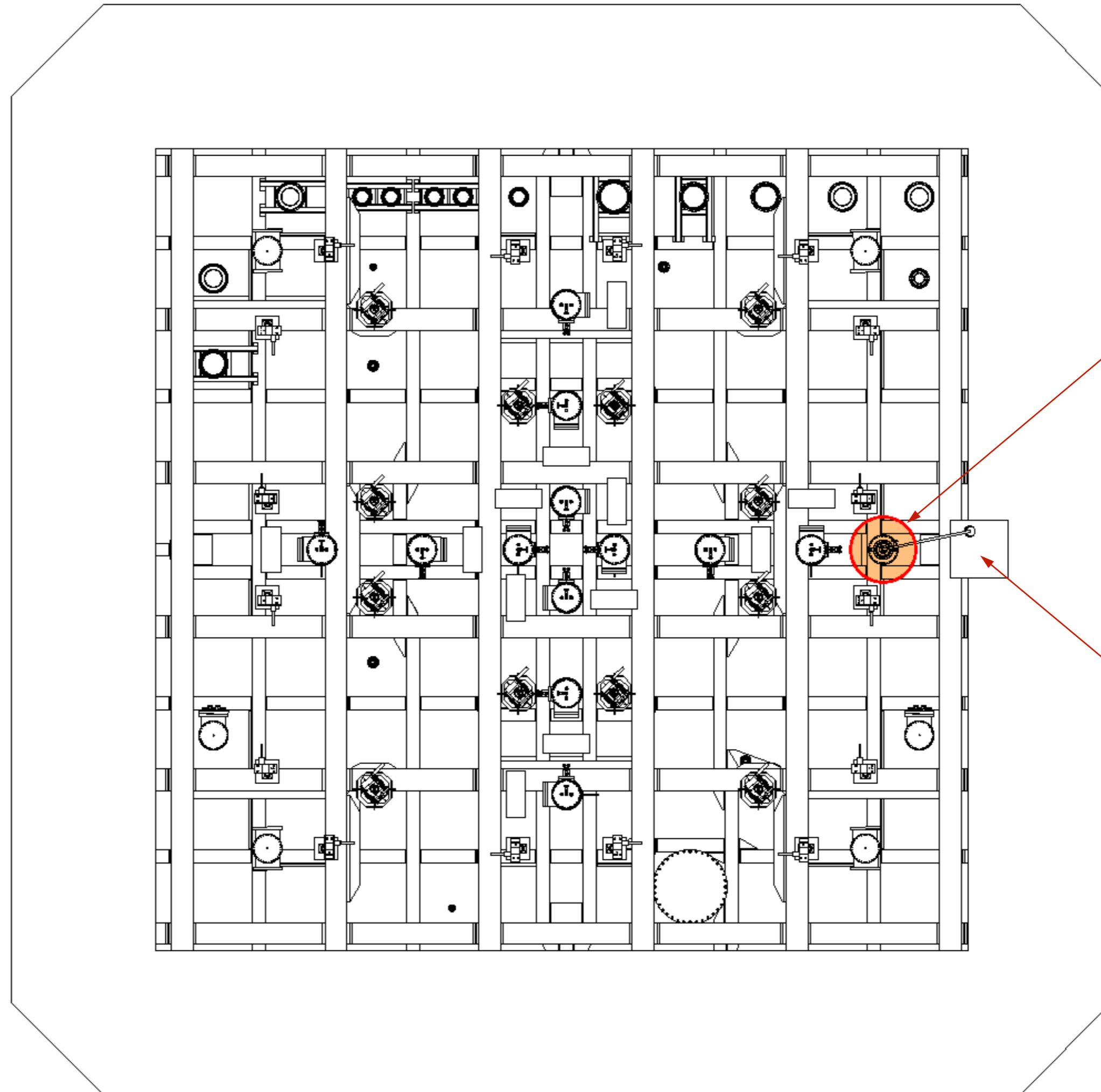

HVFT for a nominal HV up to 600kV
(present cable rated for 300kV)

300 kV HV power supply

HVFT and HV cable males

HV male for cable D=38.2mm

HVFT

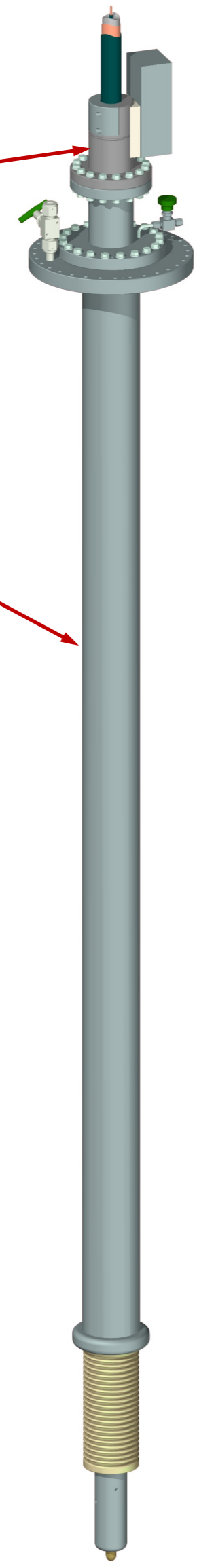

HV male for cable D=22mm

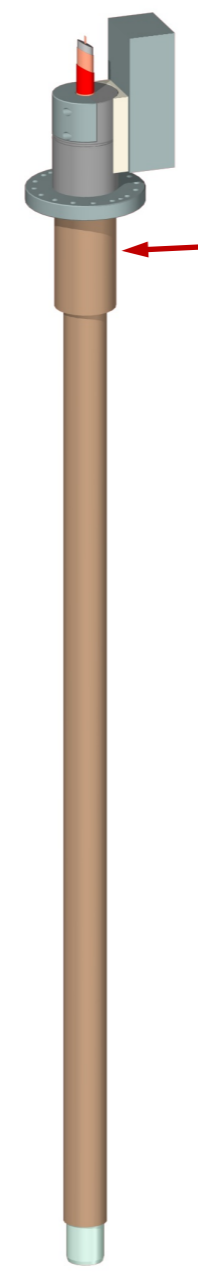

HV cable semiconductor sheath

Internal conductor

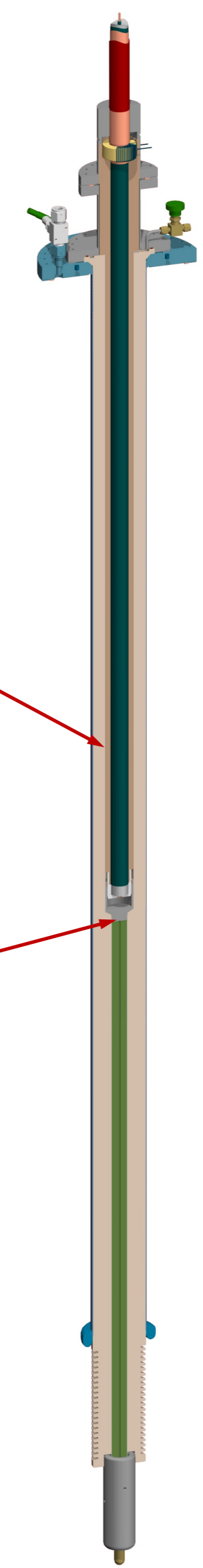

HVFT and HV cable males

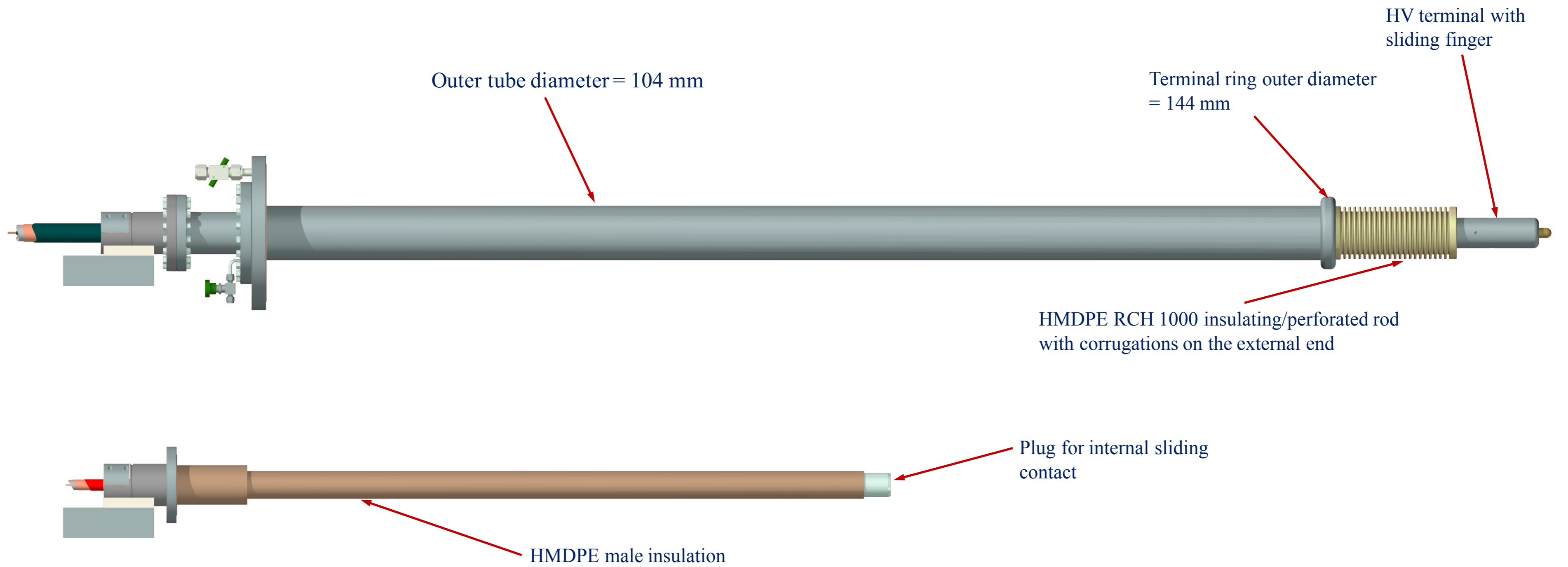

HVFT - Dimensions

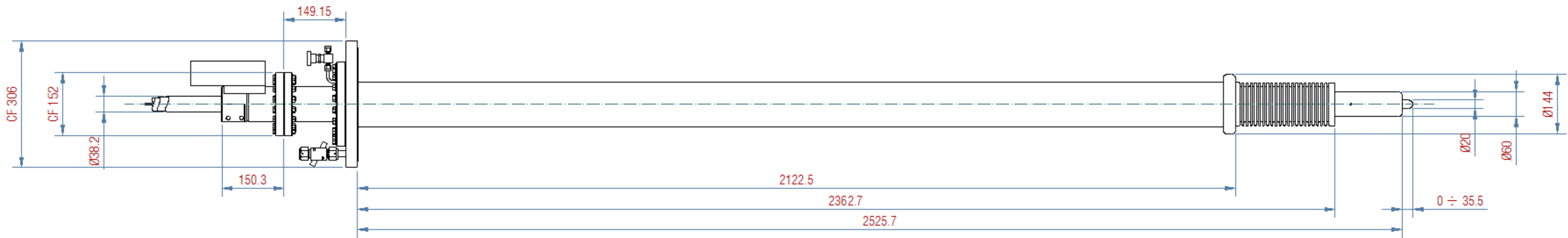

HV power supplies, HV cables and HVFTs for ProtoDUNE-DP, ProtoDUNE-SP and 311-DP

1. HV power supplies

- 1.1 300kV HV PS (300kV-1) at present connected to the 311-DP with cable $\varnothing 22\text{mm}$ (Cable 2) to be used for 666-SP.
- 1.2 300kV HV PS (300kV-2) for the 666-DP has been ordered (DAI 6649716) with cable $\varnothing 38.2\text{mm}$ (Cable 3).
- 1.3 100kV HV PS (100kV) for the 311-DP has been ordered (DAI 6673424) with cable $\varnothing 14\text{mm}$ (Cable 1).
- 1.4 200kV HV PS (200kV) as spare for the 666-SP with cable $\varnothing 38.2\text{mm}$ (Cable 3).

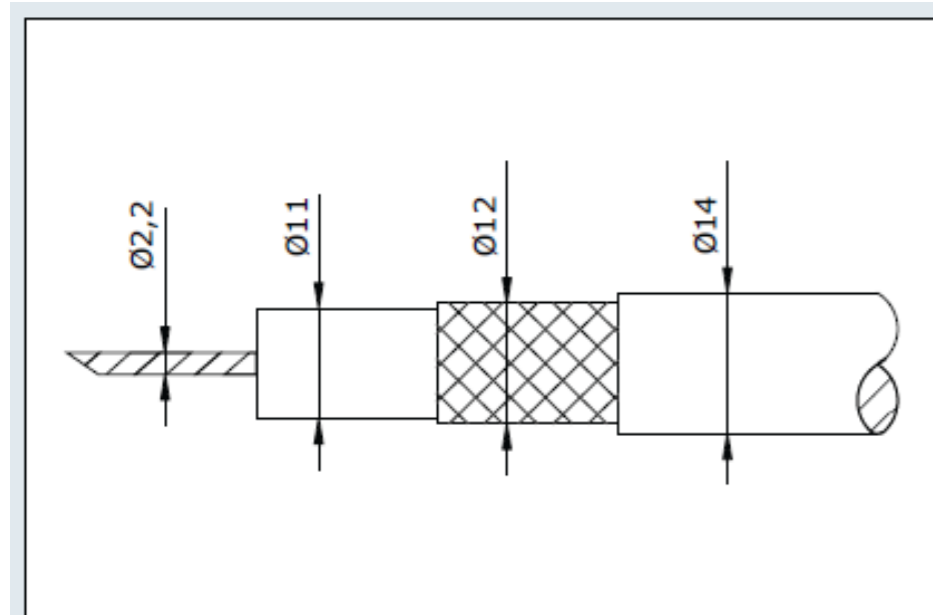

Cable 1

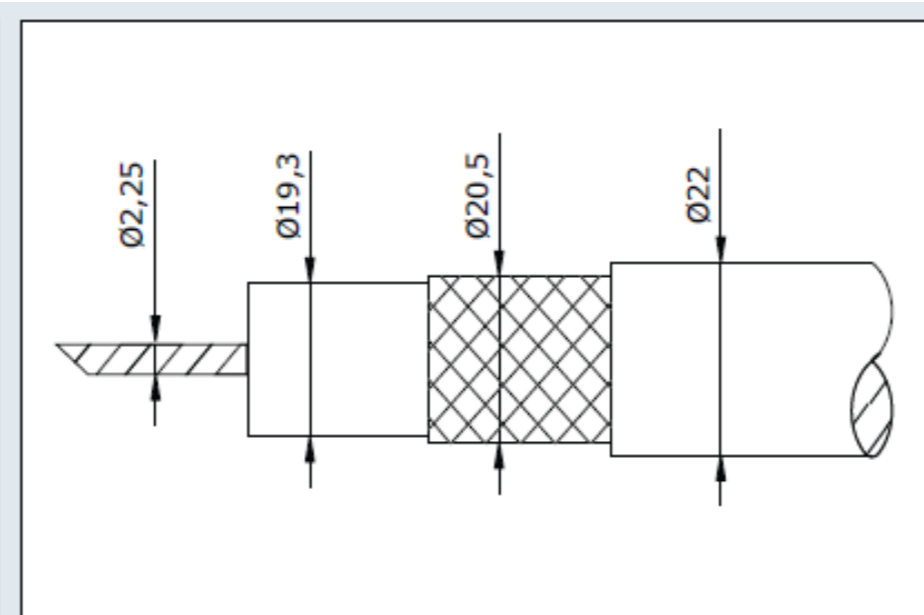

Cable 2

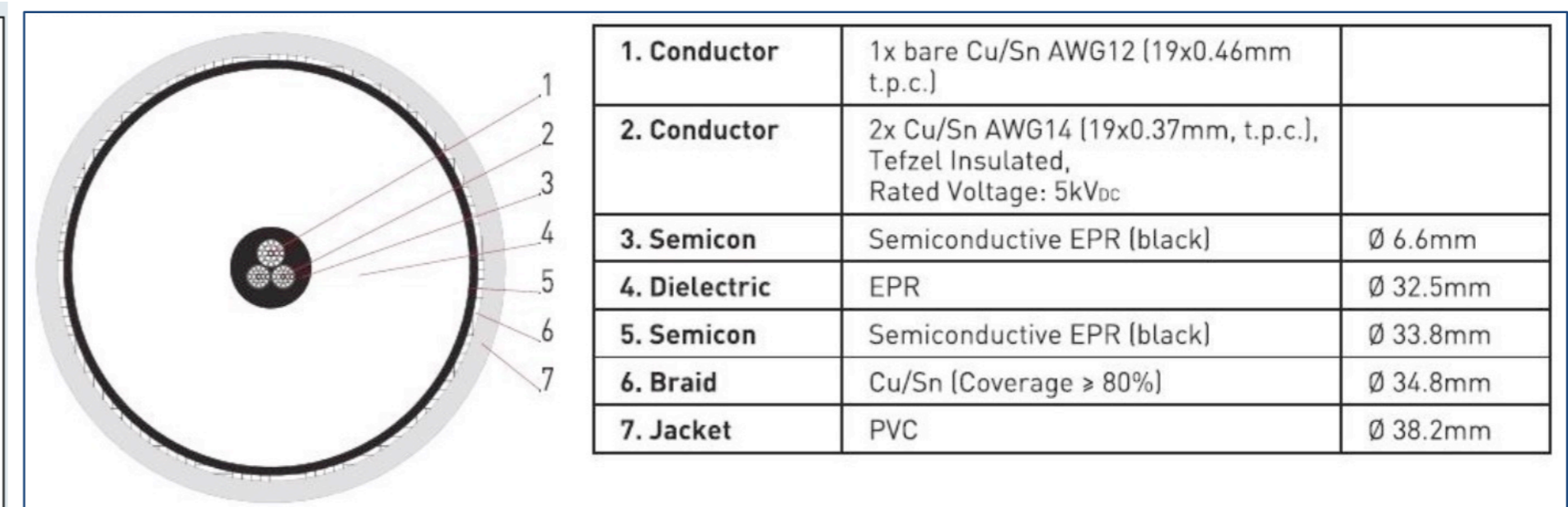

Cable 3 (3/C – 320kV LOW NOISE FLEXIBLE X-Ray 2236)

Pictures of 300 kV HV power supply with cable Type 2 with male plug and cable Type 3



Heinzinger 300 kV Power supply



Heinzinger 300 kV Power supply



Cable 3

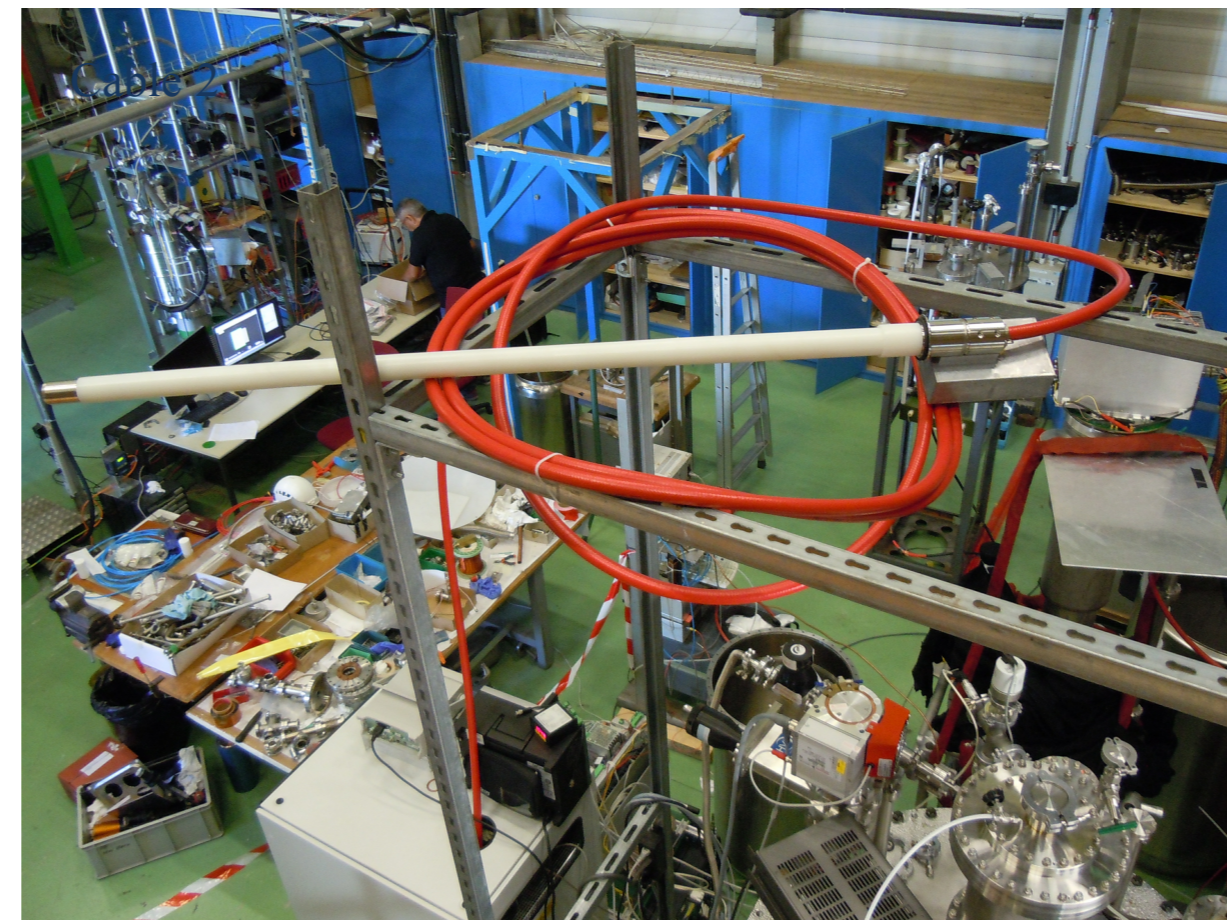

Cable 2

HV cable plugs and “corona” detector

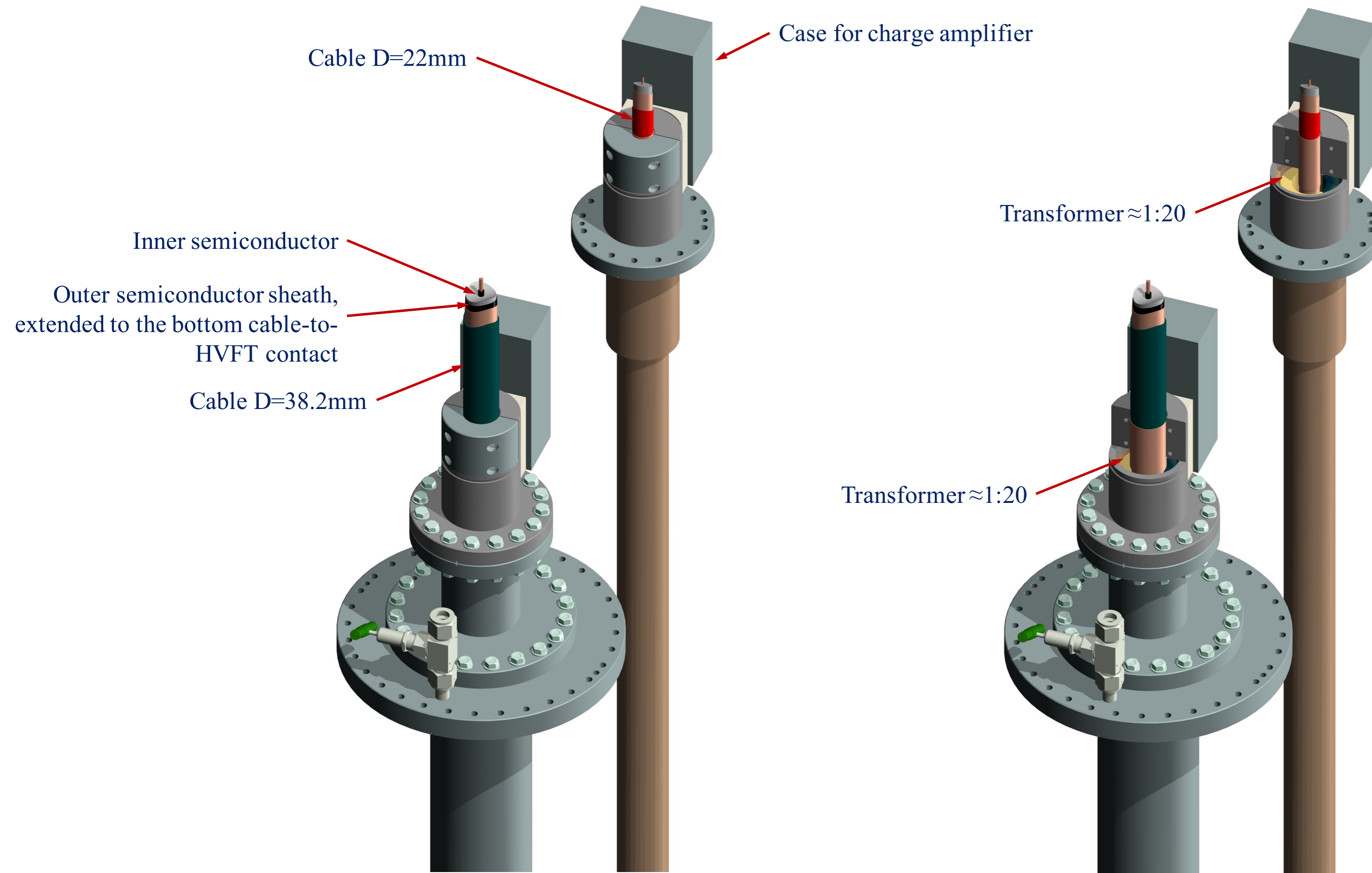

Penetration and floating contact HVFT-to-cathode

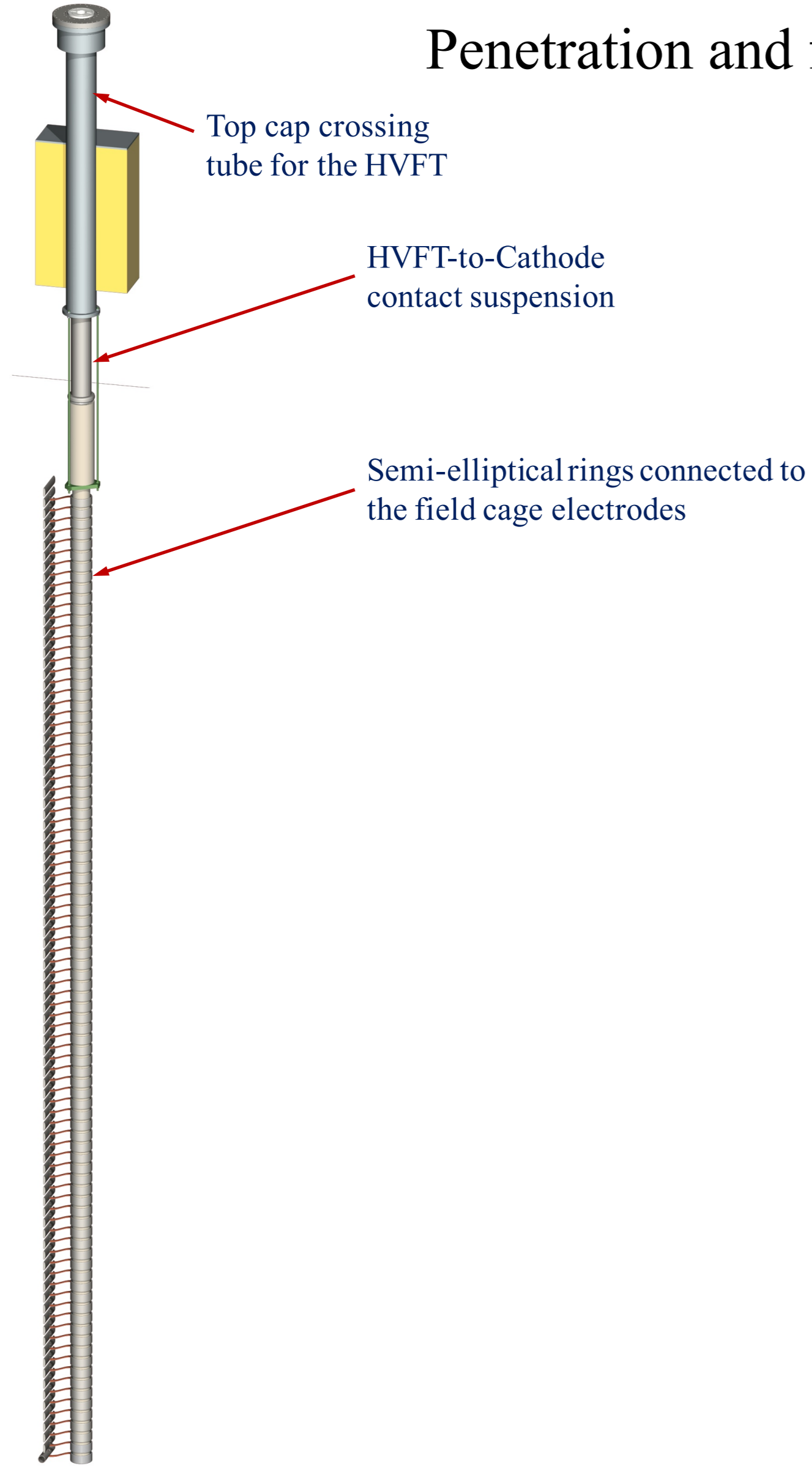

Weights of the HVFT-Cathode connection:

	Room temperature	LAr
HMDPE	35.7 kg	-18.6 kg
Semi-elliptical rings (Al)	35.7 kg	17.2 kg
Inner SS contact	4.0 kg	3.3 kg
Total	75.4 kg	1.9 kg

Penetration and floating contact HVFT-to-cathode (top)

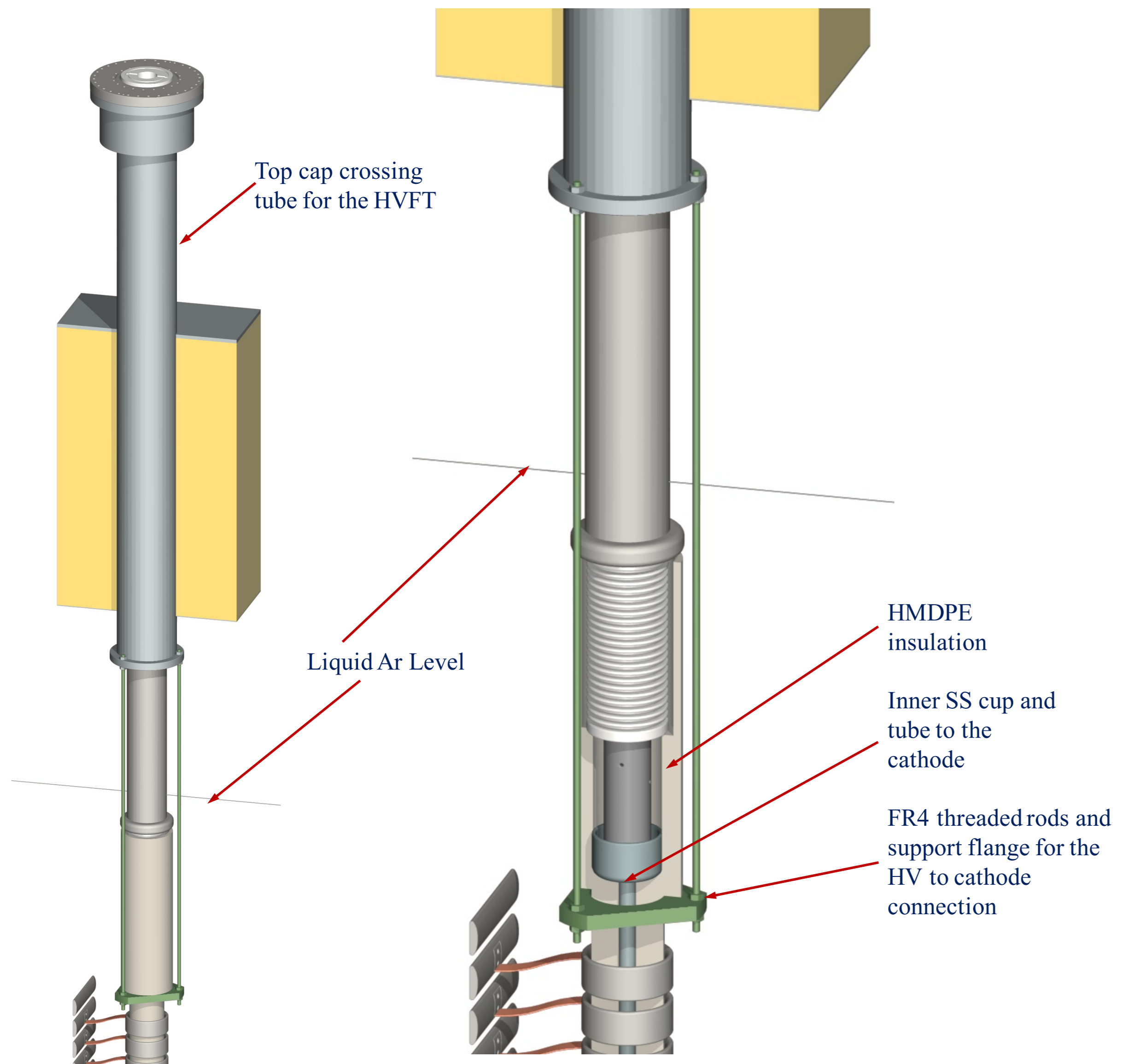

Penetration and floating HVFT-to-cathode connection (bottom)

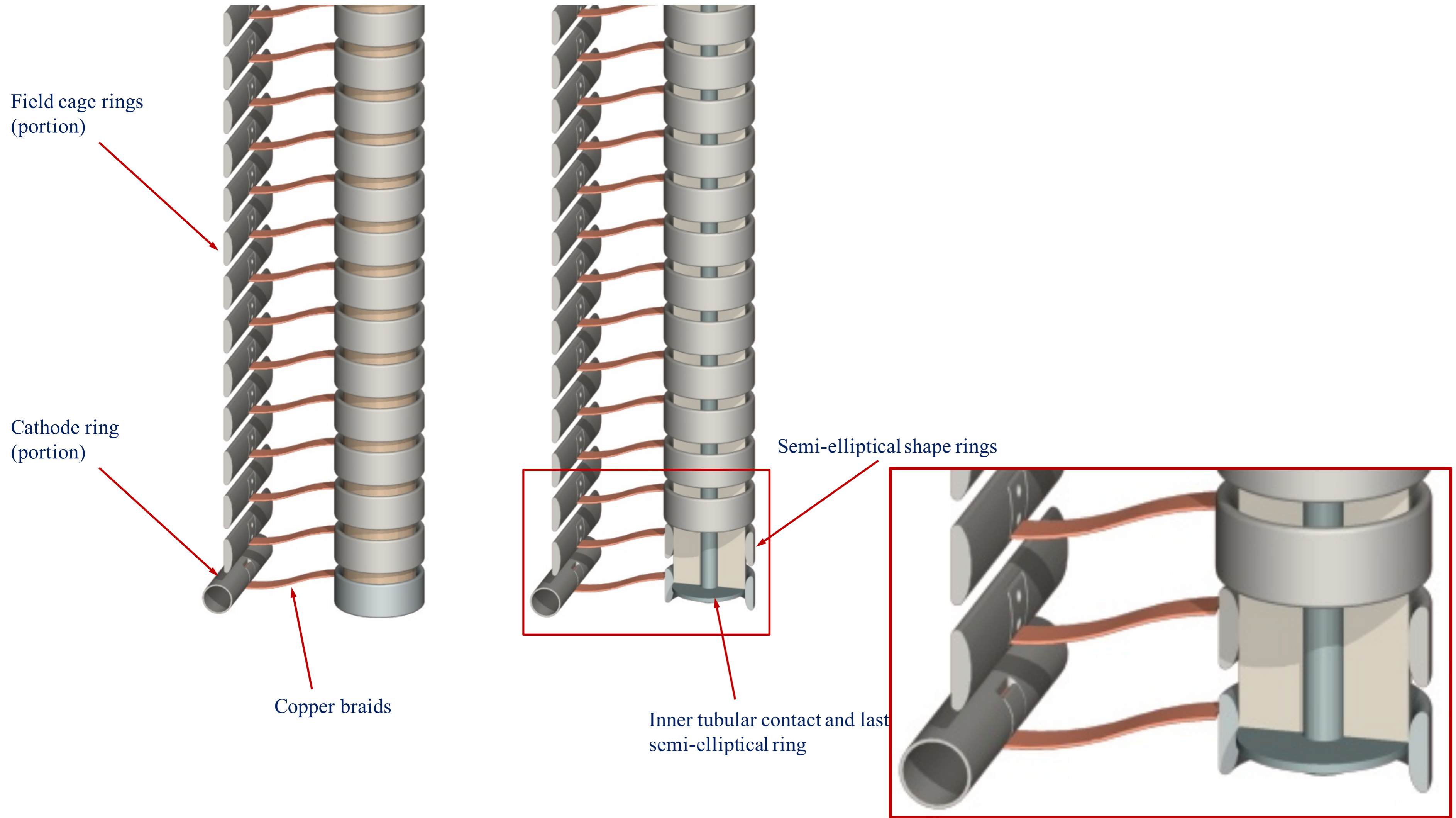

D) HVFT + connection to the cathode

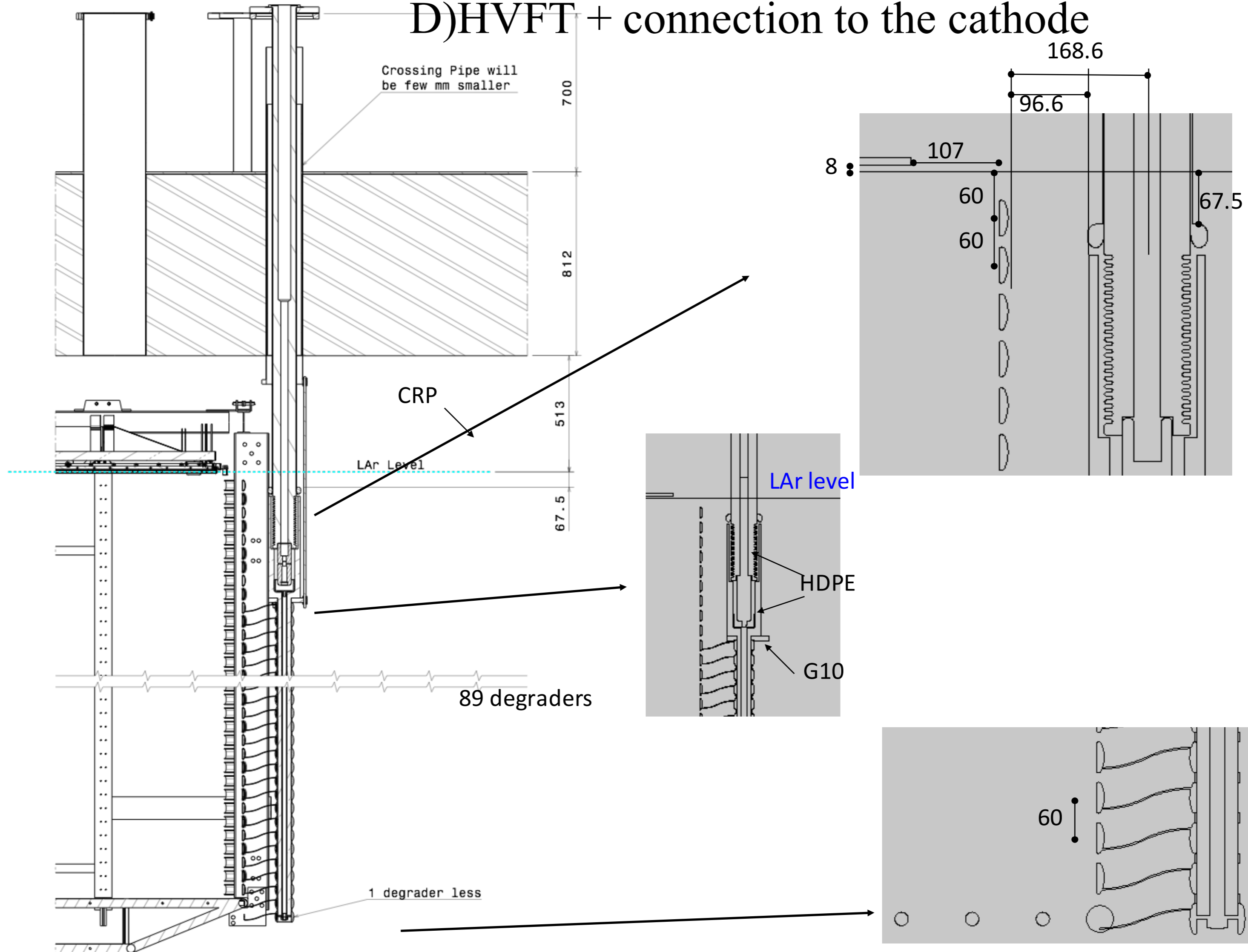

D) HVFT + connection to the cathode

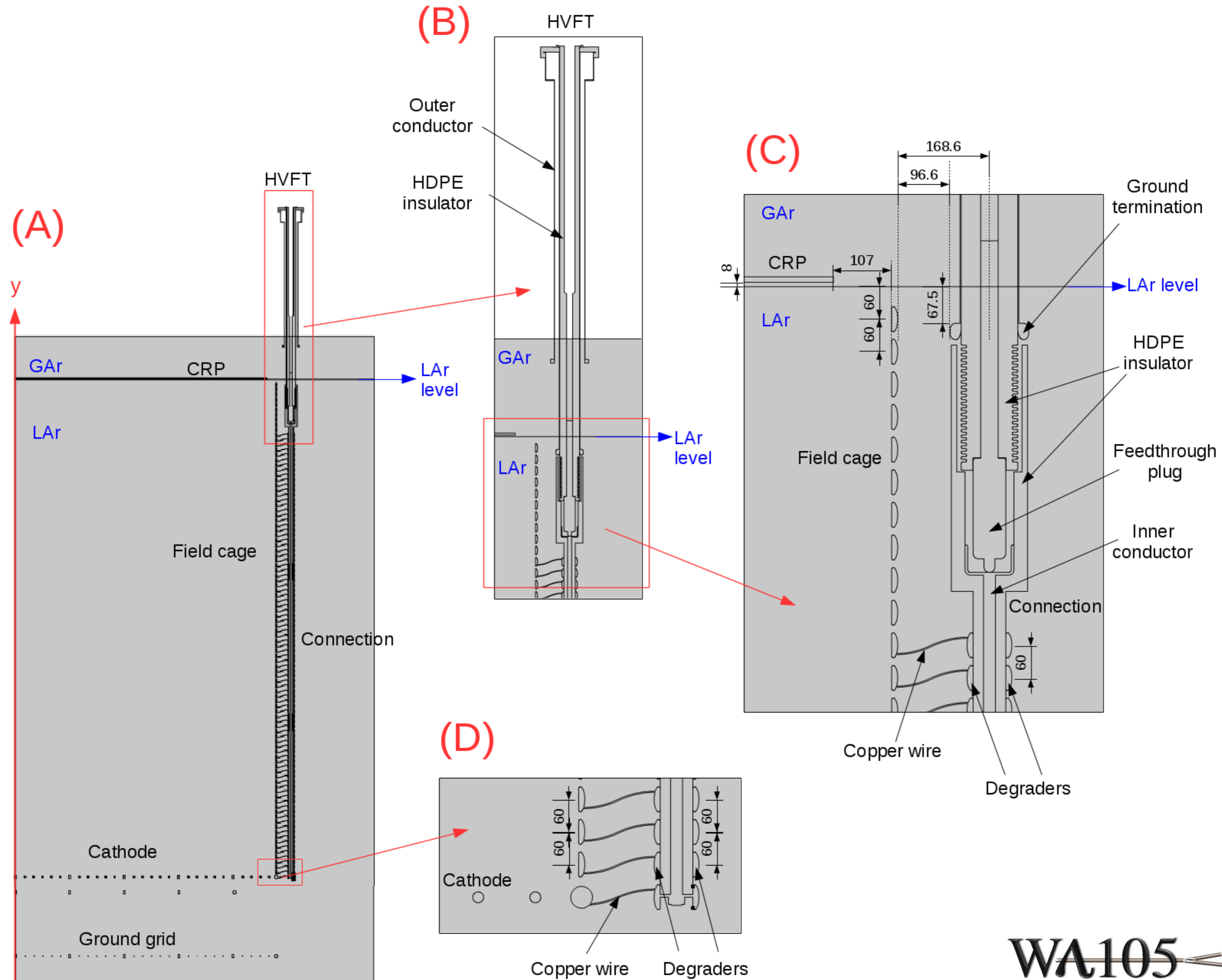

D) HVFT + connection to the cathode

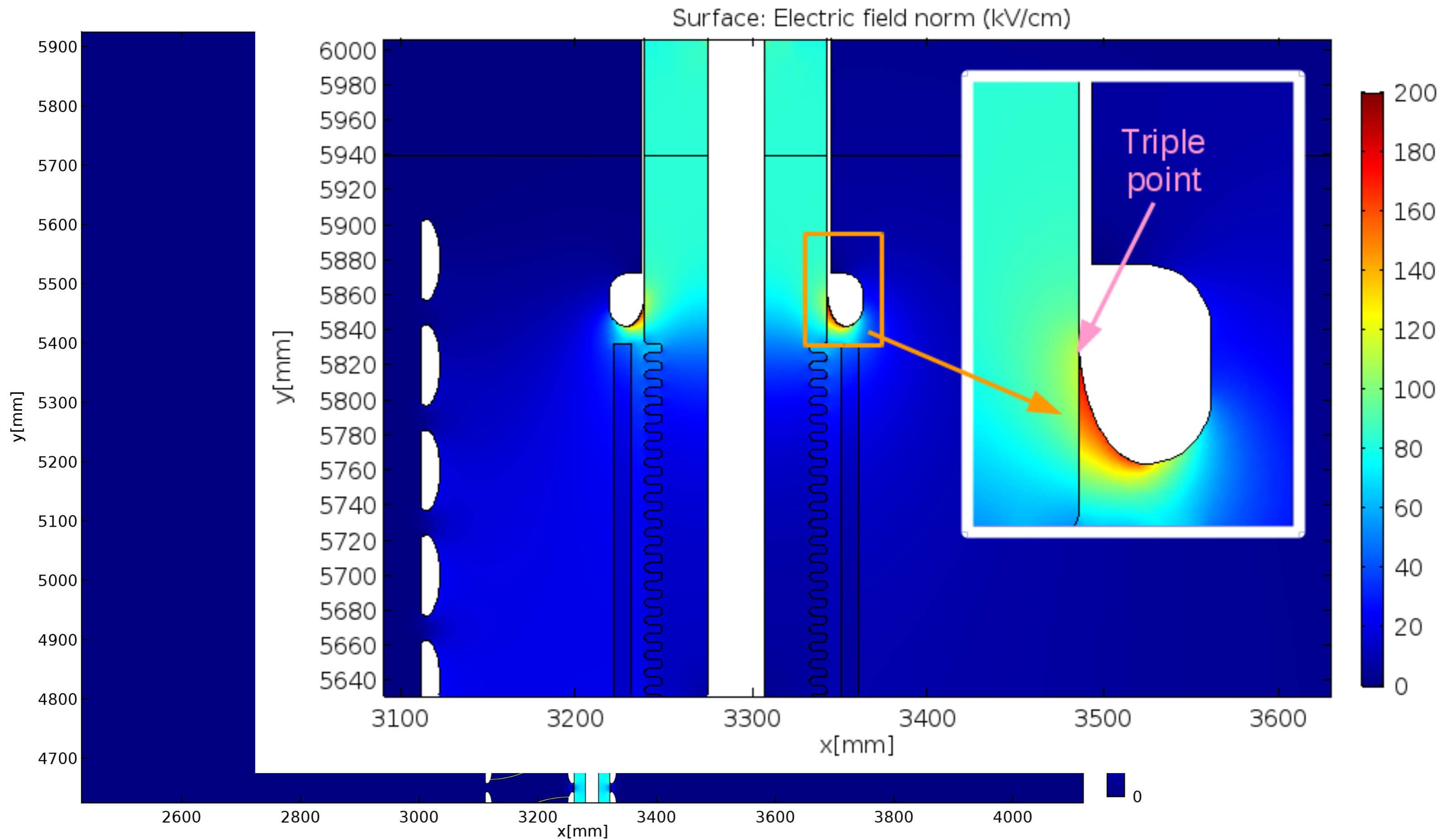

Electric field locally higher than our guideline, electric field in LAr below 40 kV/cm

D) HVFT + connection to the cathode

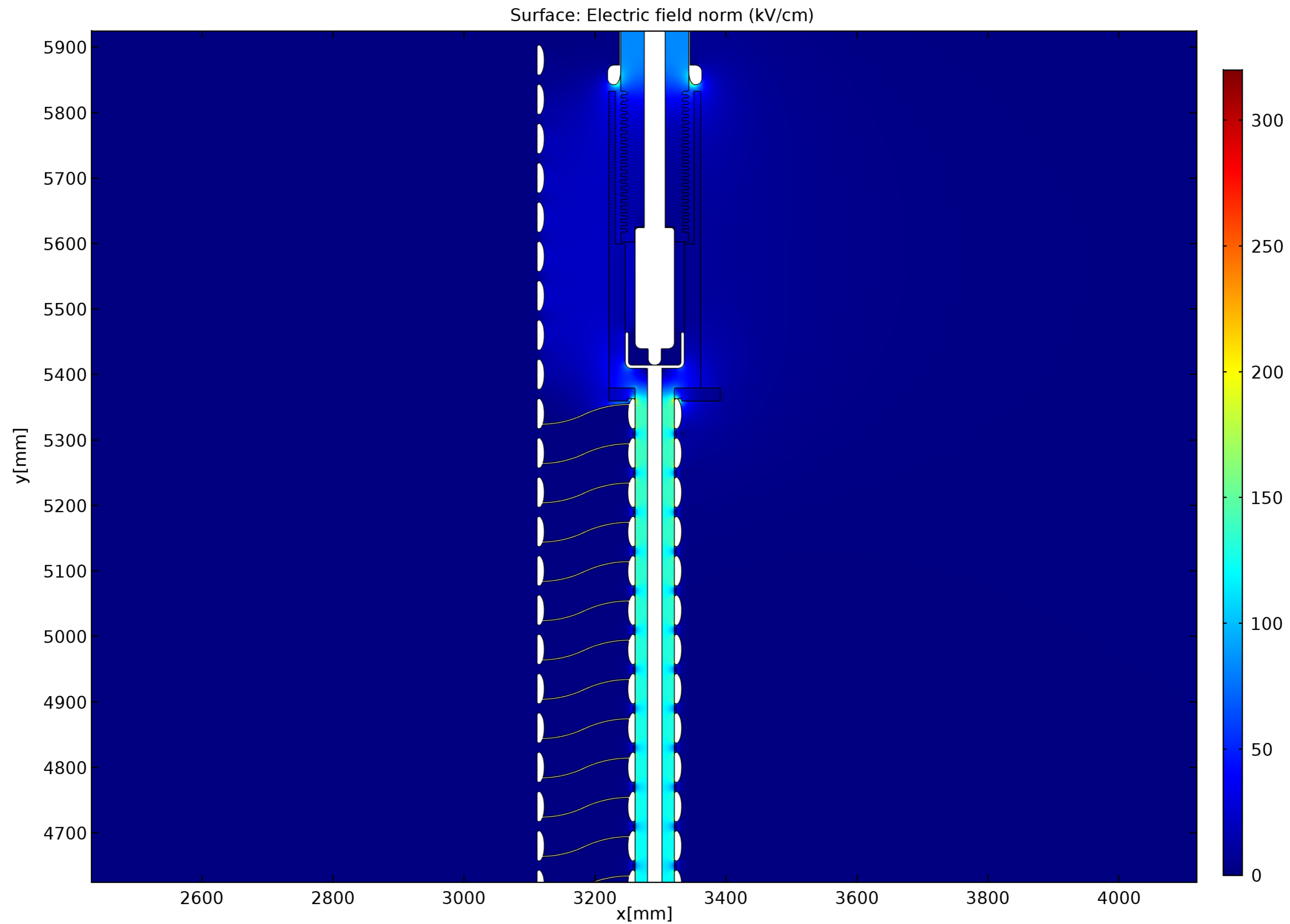

D) HVFT + connection to the cathode

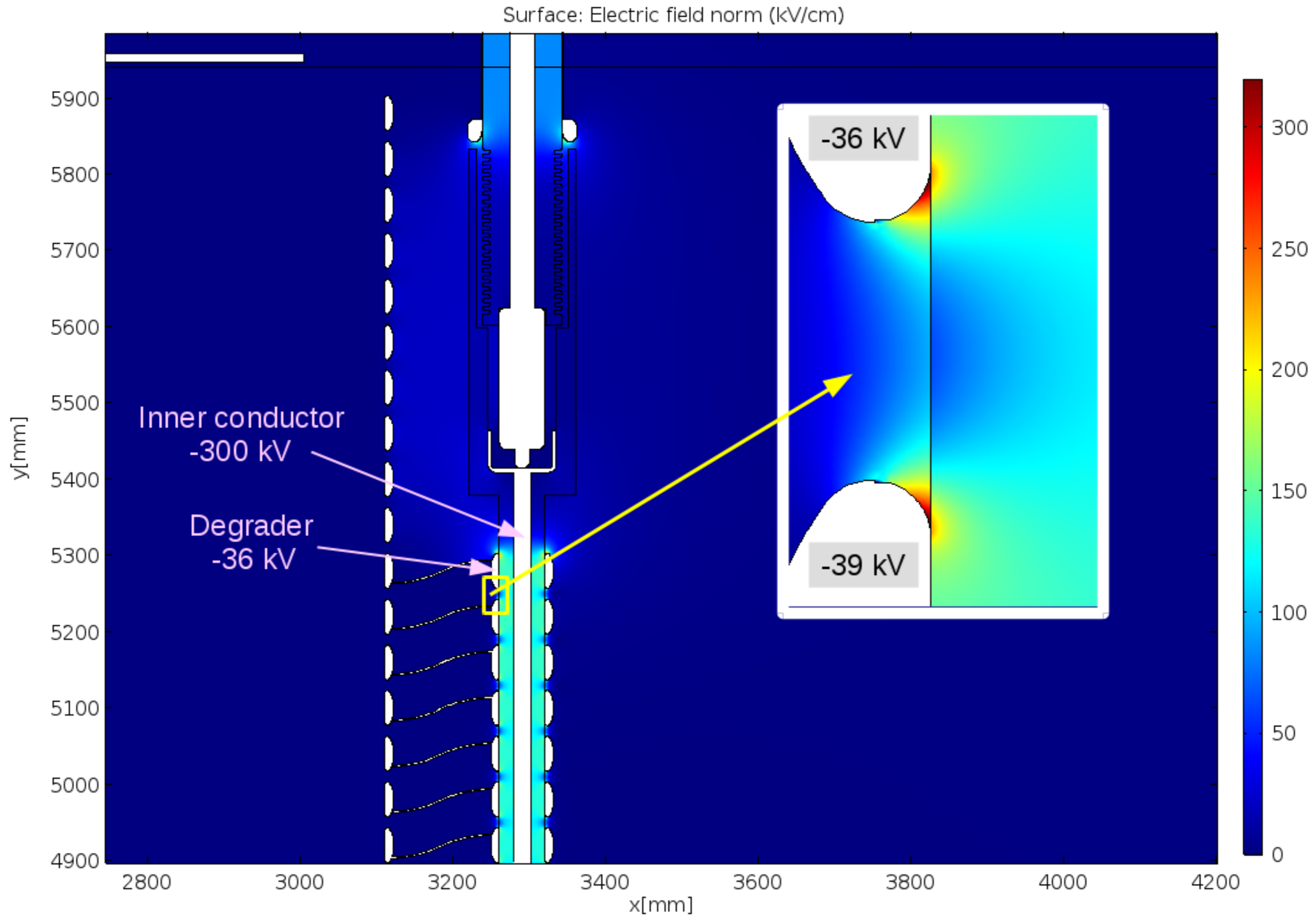

D) HVFT + connection to the cathode

With Degraders

Without Degraders

[kV/cm]

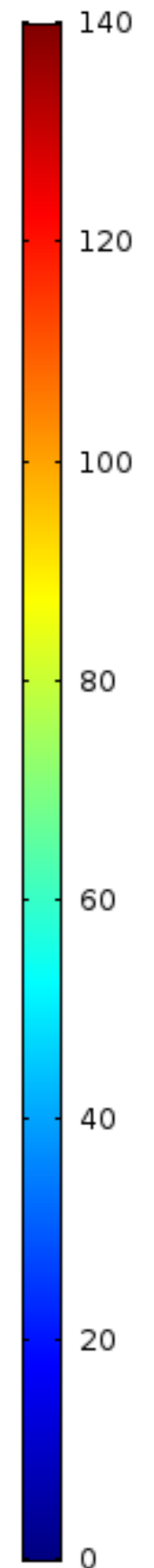
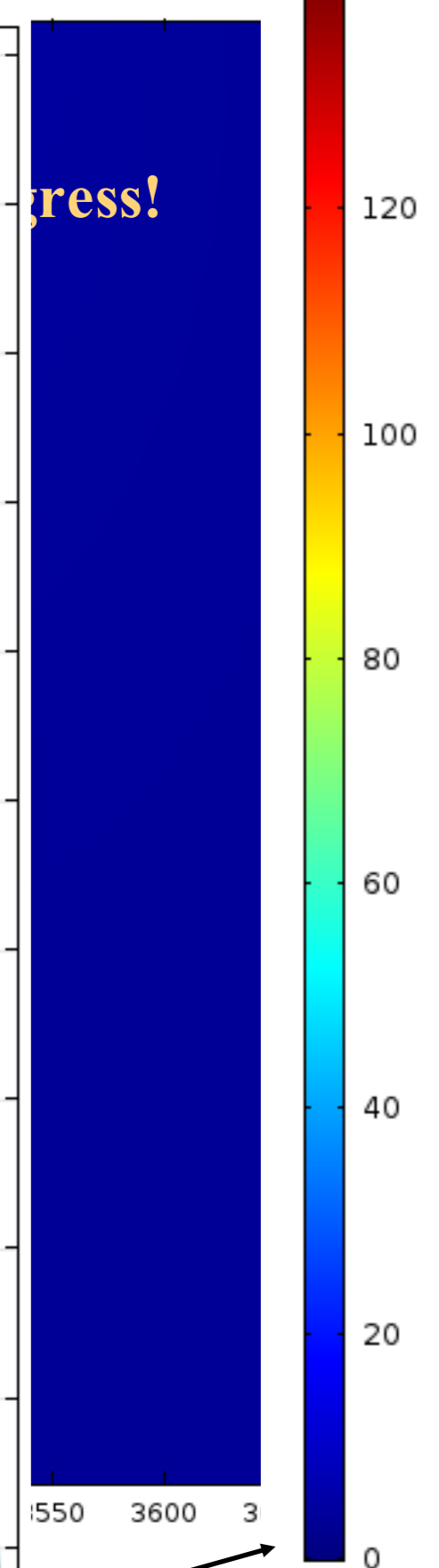
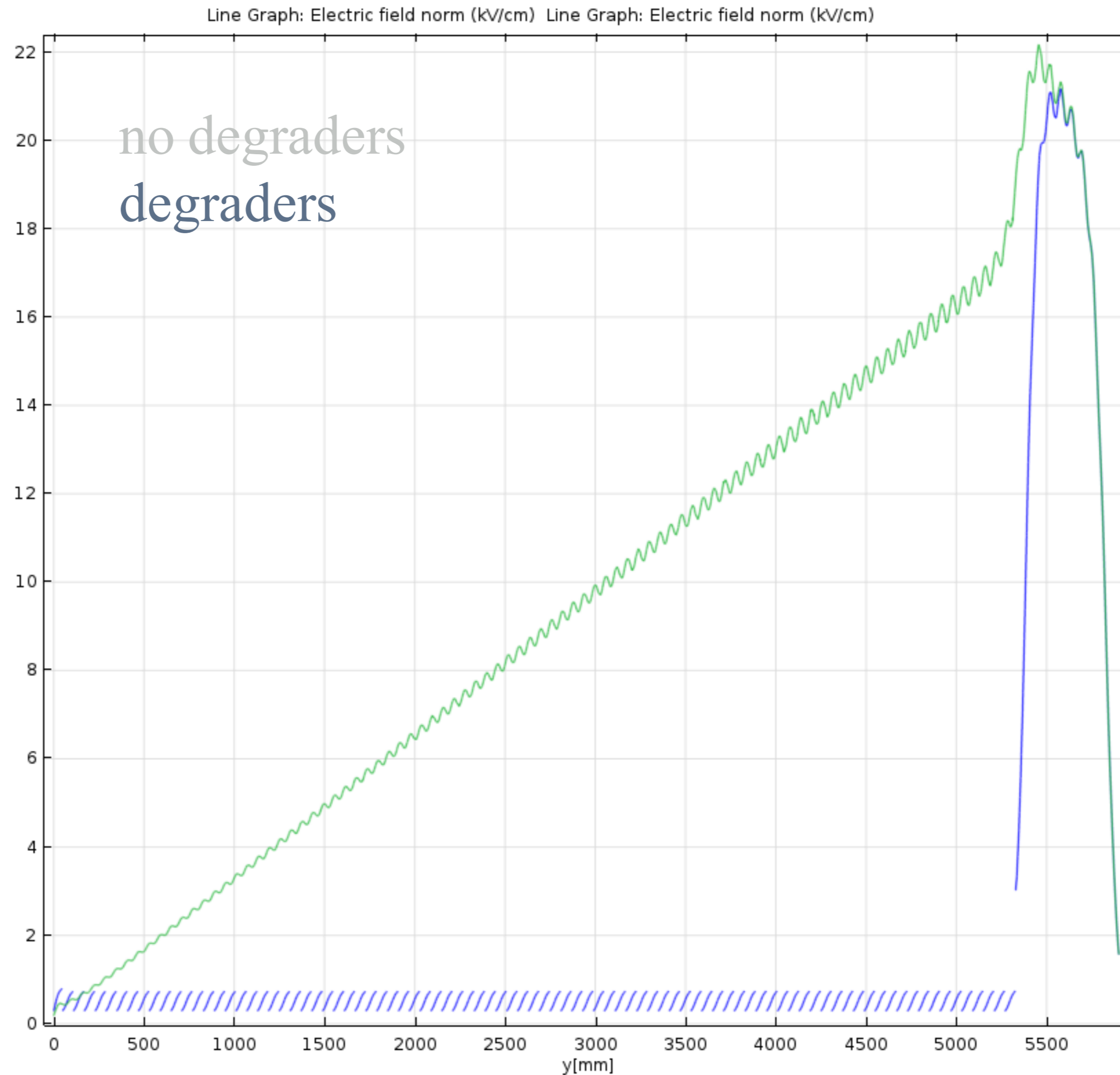
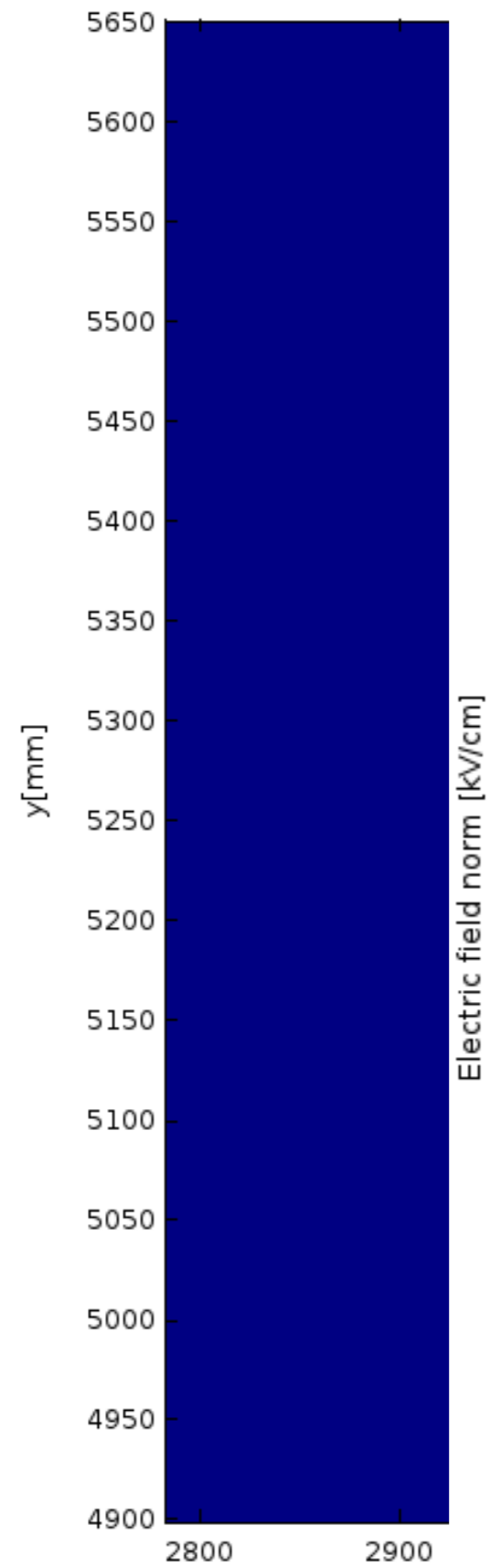

D) HVFT + connection to the cathode

- Improved design done by **Franco** to **minimise the high electric field locally**.

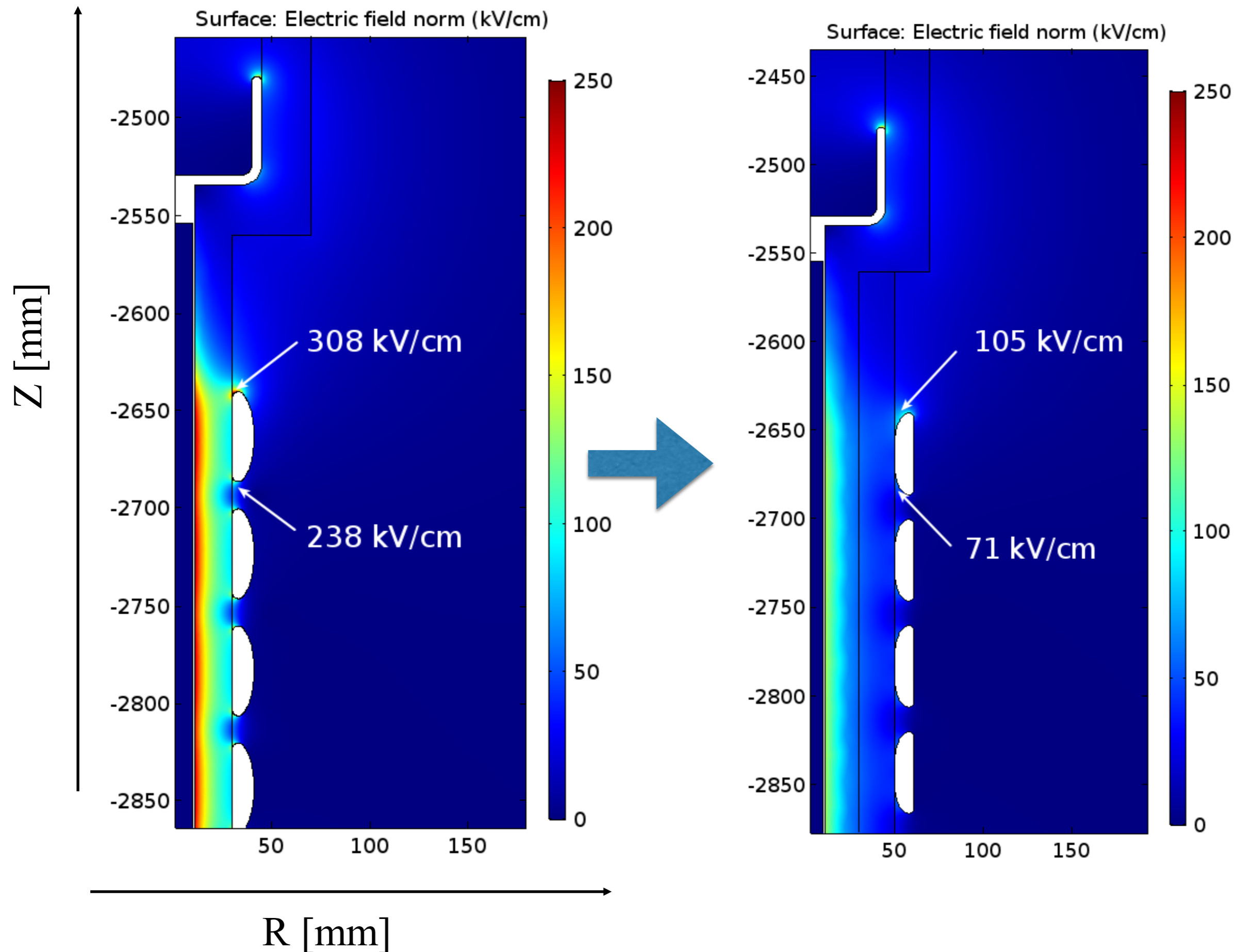

Main changes:

- **HDPE thicker**
- **New degrader shape**
- **No G10 spacers**

We need to verify mechanically the design

D)HVFT + connection to the cathode

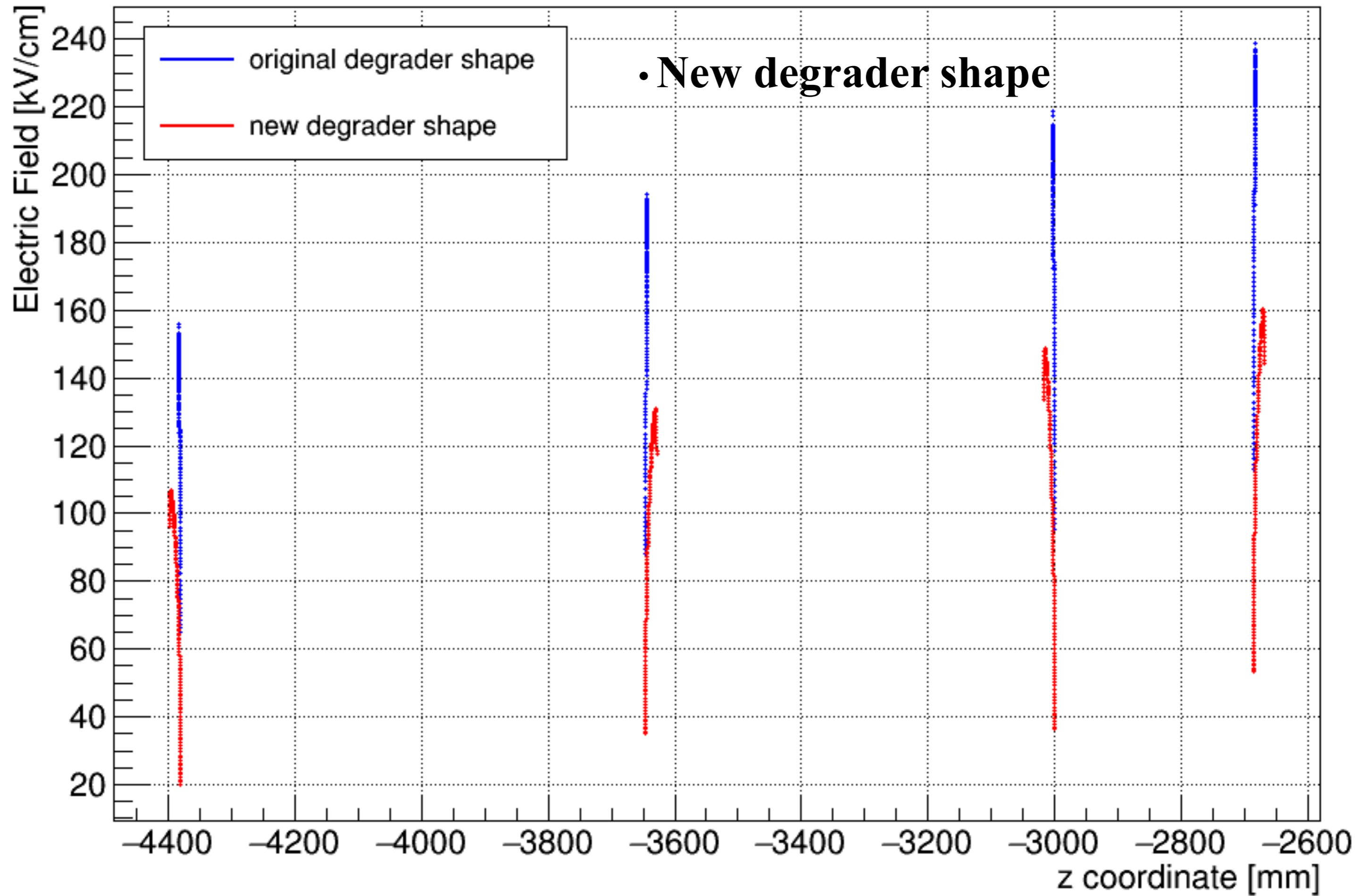

D) HVFT + connection to the cathode

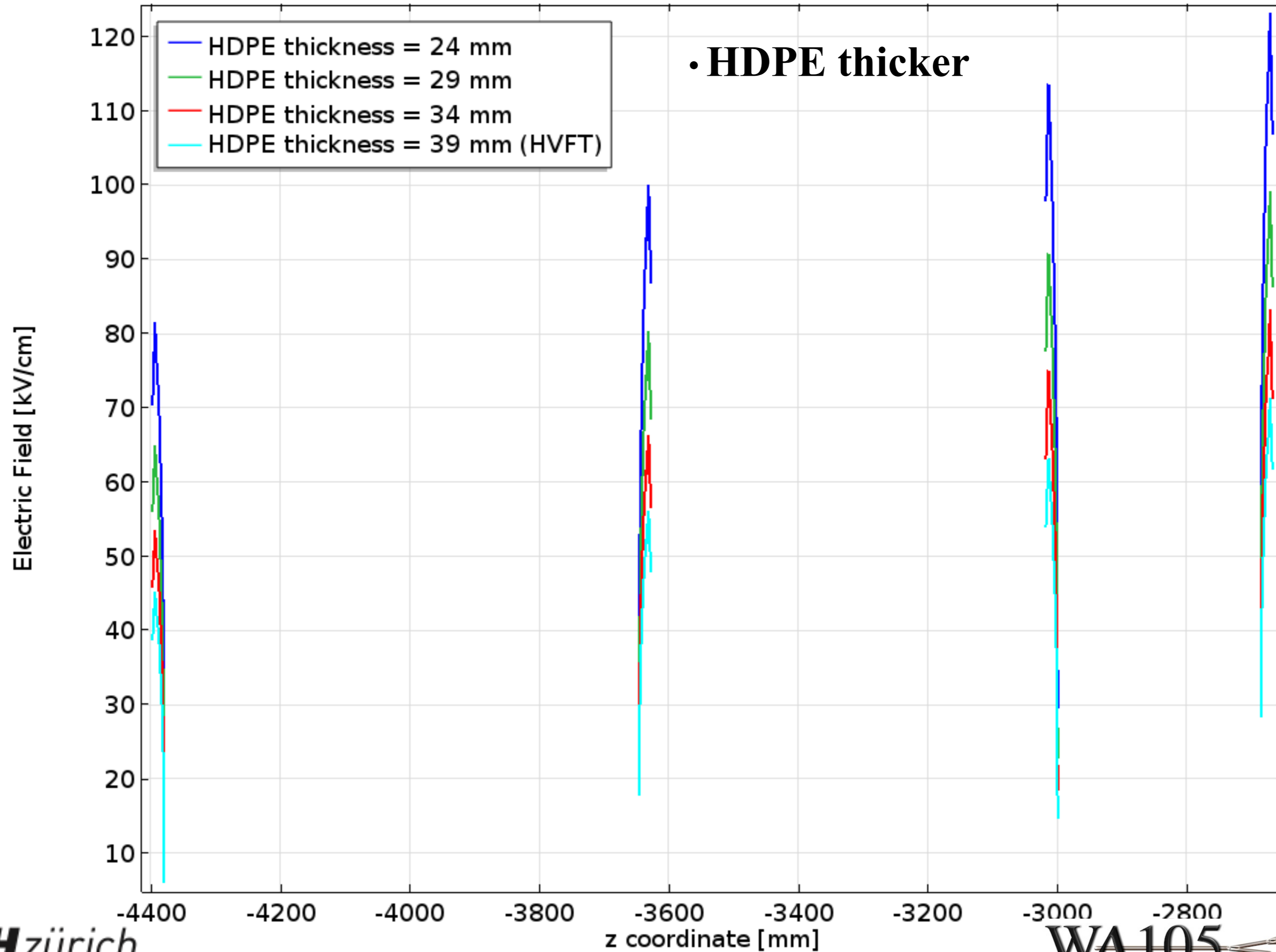

D)HVFT + connection to the cathode

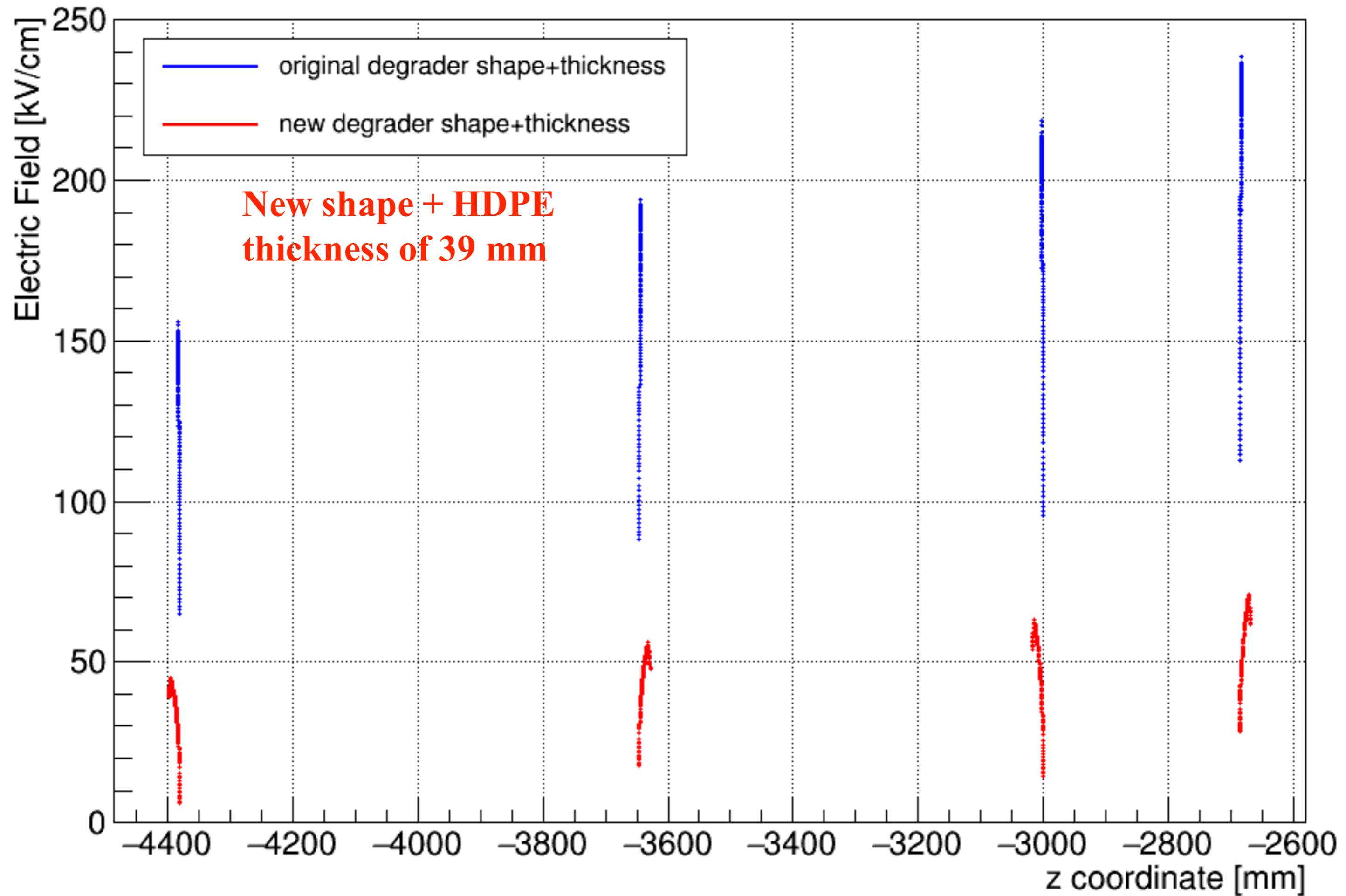

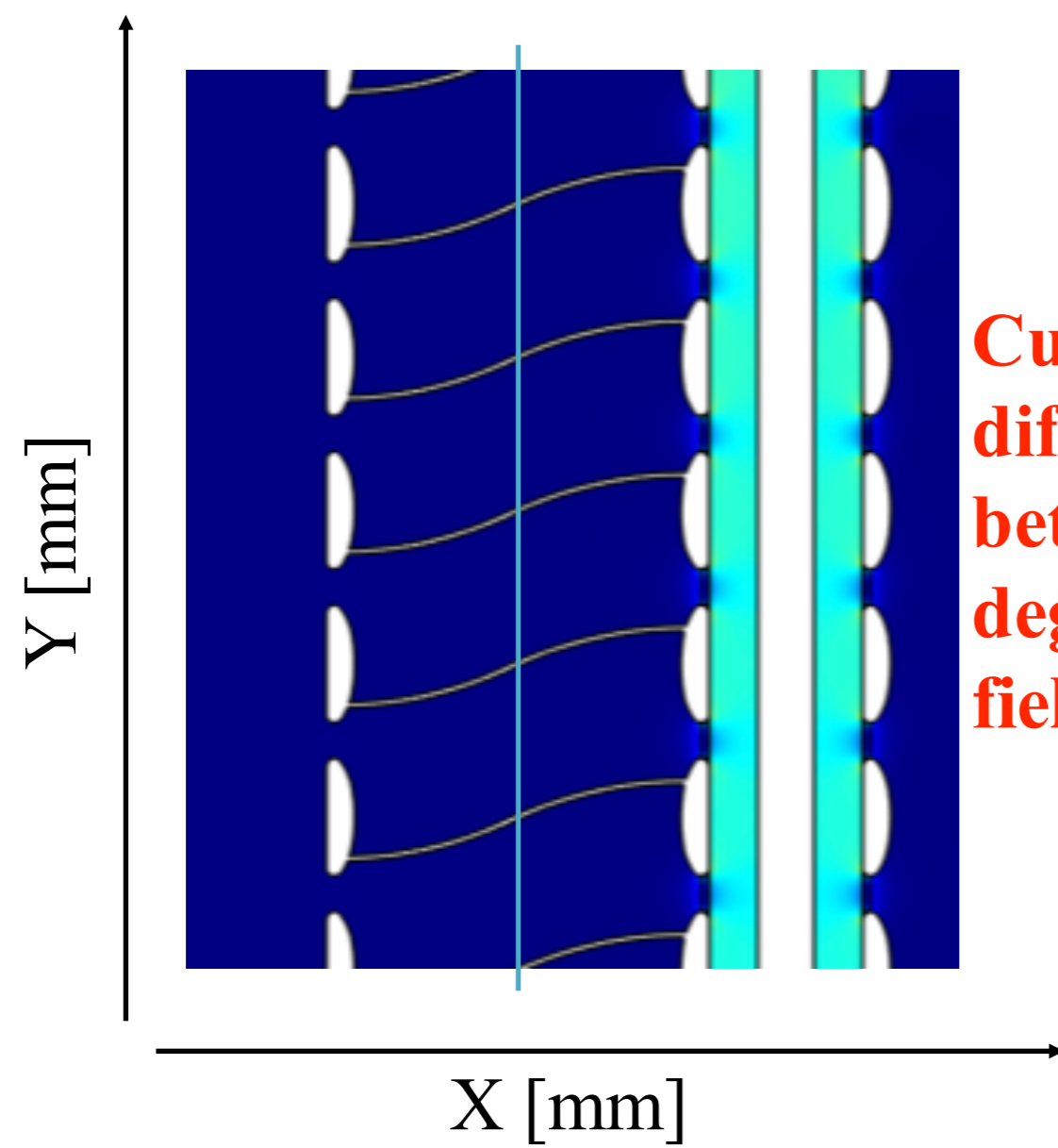

Cut Line at different distances between the degrader and the field cage

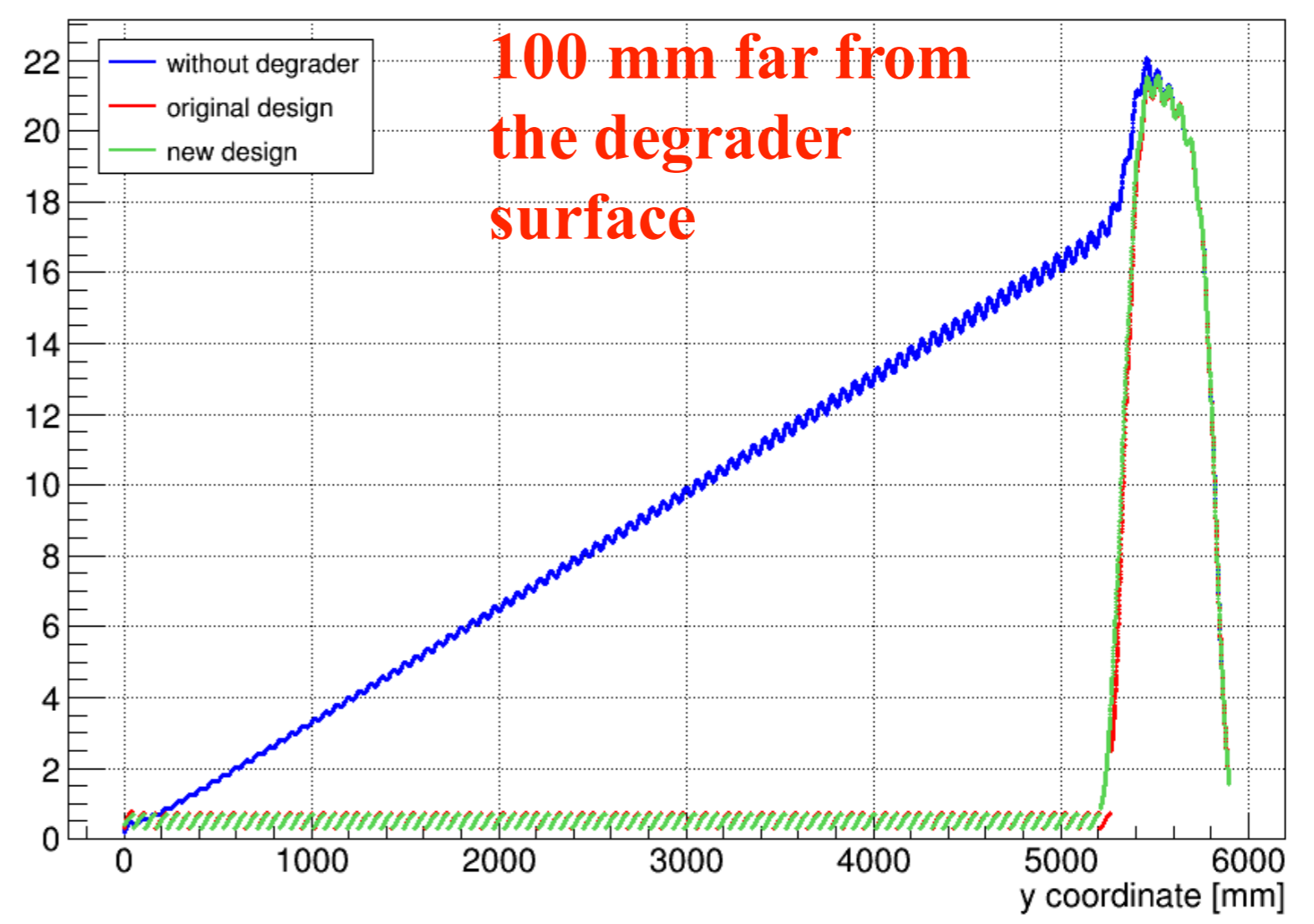
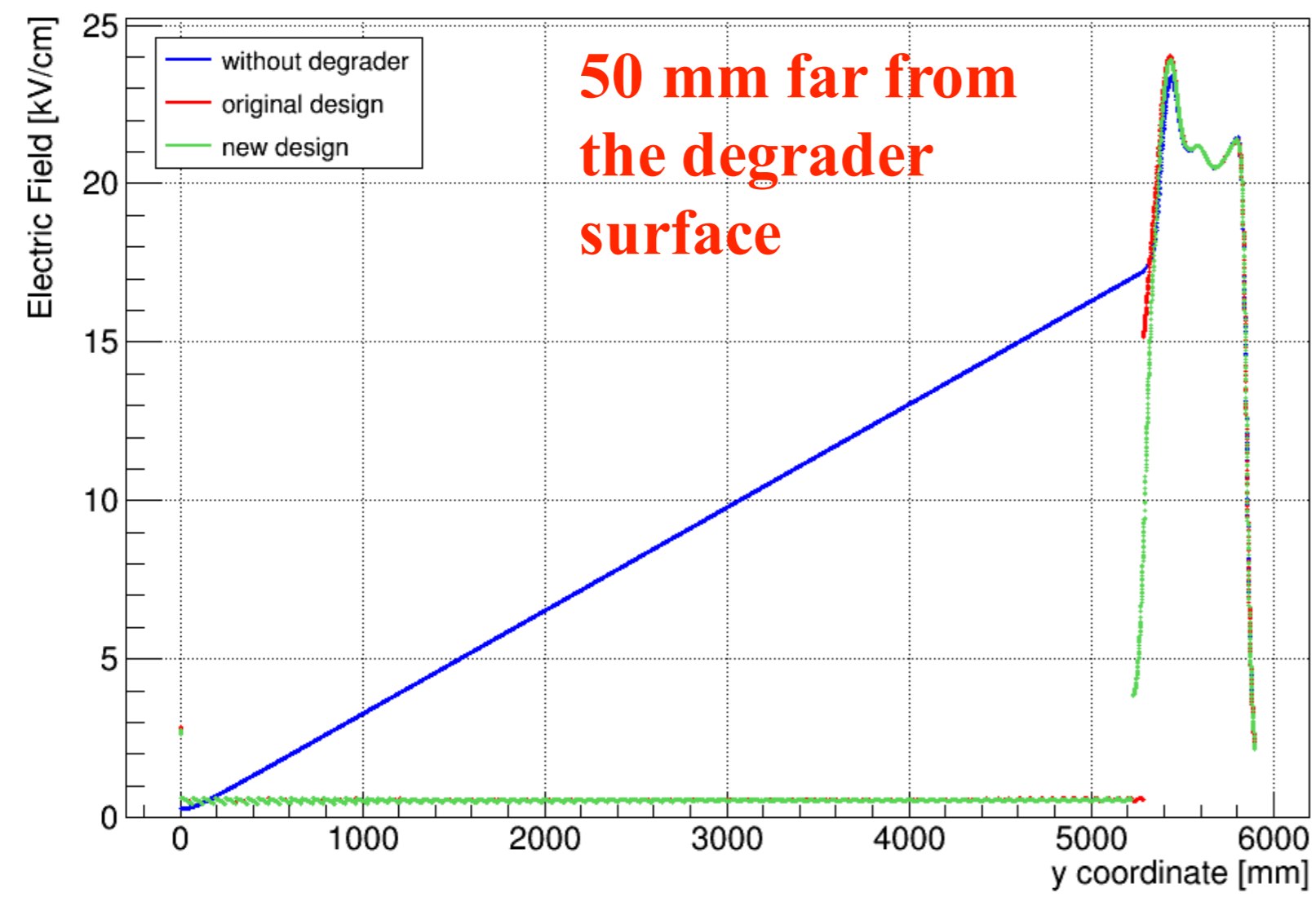
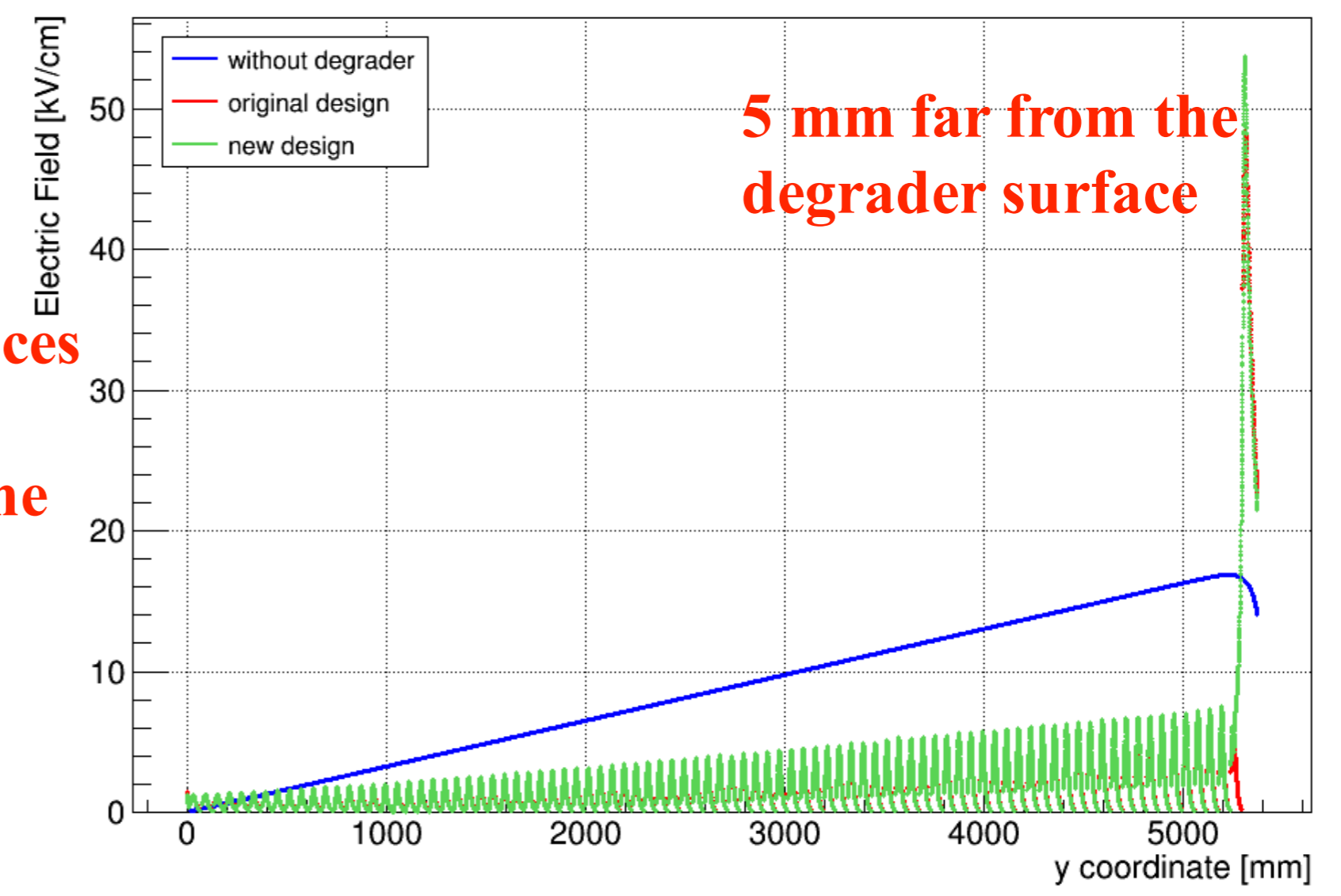

SPARE SLIDES

Past experience on HVFT

Test on a HVFT for the 311 Dual-Phase Demonstrator

A HVFT similar to the one proposed, but 40cm shorter, has been installed in the 311 DP Demonstrator.

This HVFT has been tested at $\sim 300\text{kV}$ in a test cryostat.

The results have been published in [JINST: 12 P03021](#), [arXiv:1611.02085](#)

HVFT for the ArDM and for ICARUS experiments

HVFTs with similar configuration, but designed for 75-150kV operation in LAr have been designed, built, tested and are at present in operation for the ArDM experiment at Canfranc and for the ICARUS detector at Gran Sasso Laboratory (several years operation at -75kV and one week at -150kV , at present departing for FNAL).

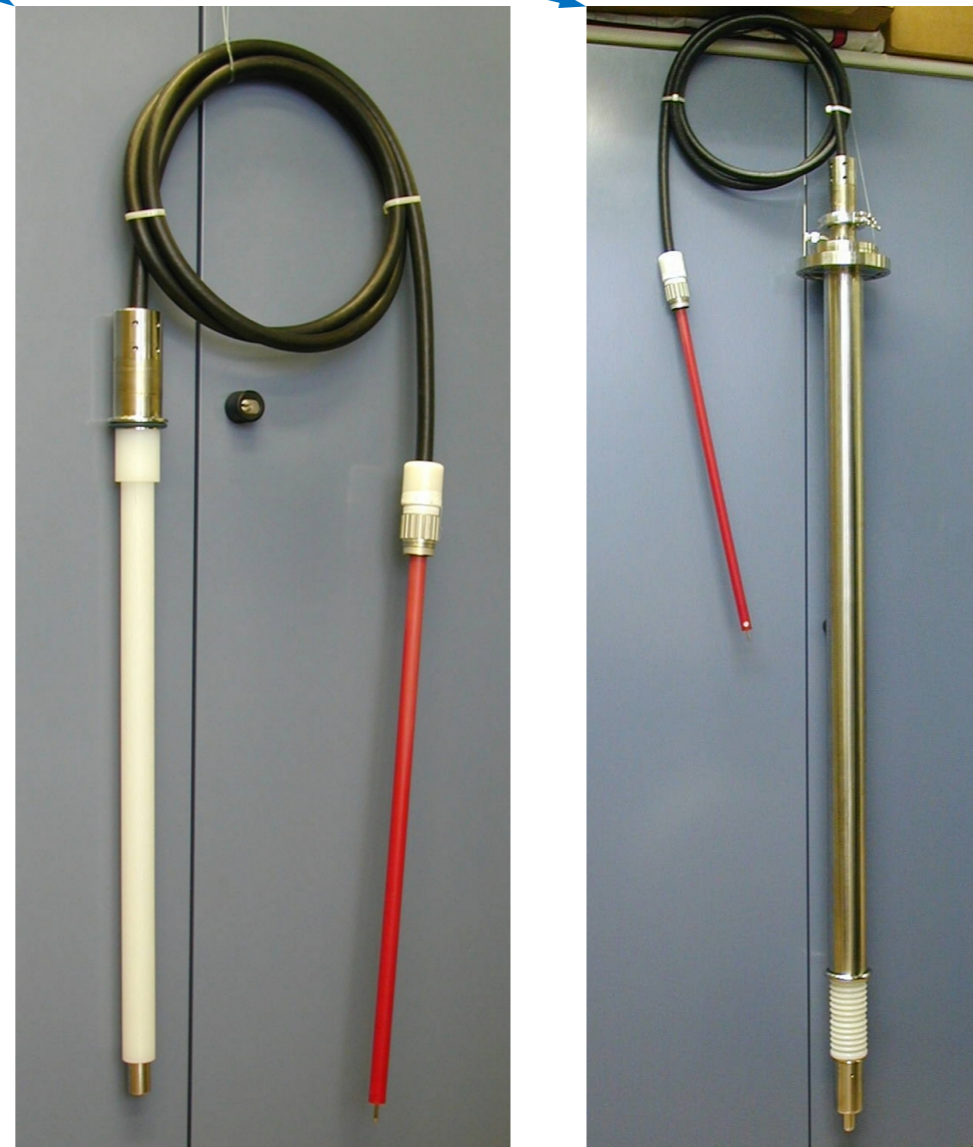

Where we are?

A 300 KV feedthrough designed for the 3x1x1 WA105 and for protoDUNE-DP:

- The HVFT was successfully tested at CERN until the end of scale of the power supply, -295kV.
- It is already installed in the 3x1x1 where will be operating at -50 kV

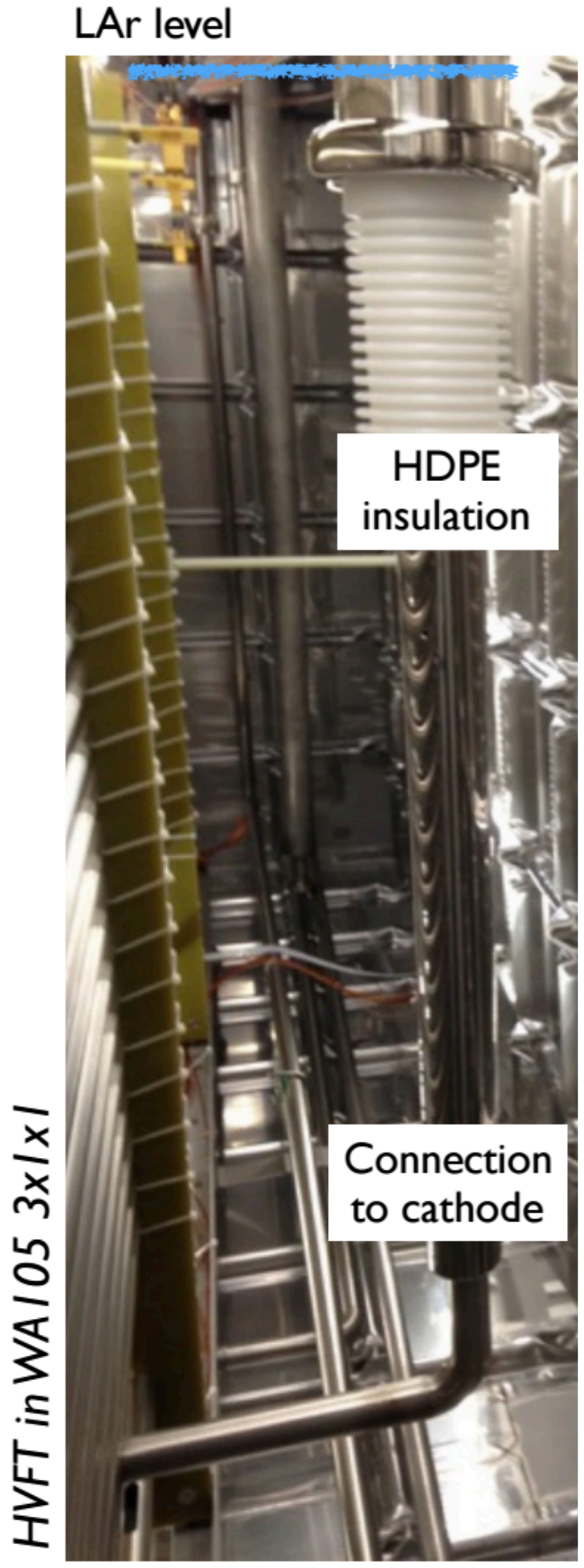

C. Cantini et al., “First test of a high voltage feedthrough for liquid Argon TPCs connected to a 300 kV power Supply”,

JINST 12 P03021 arXiv:1611.02085

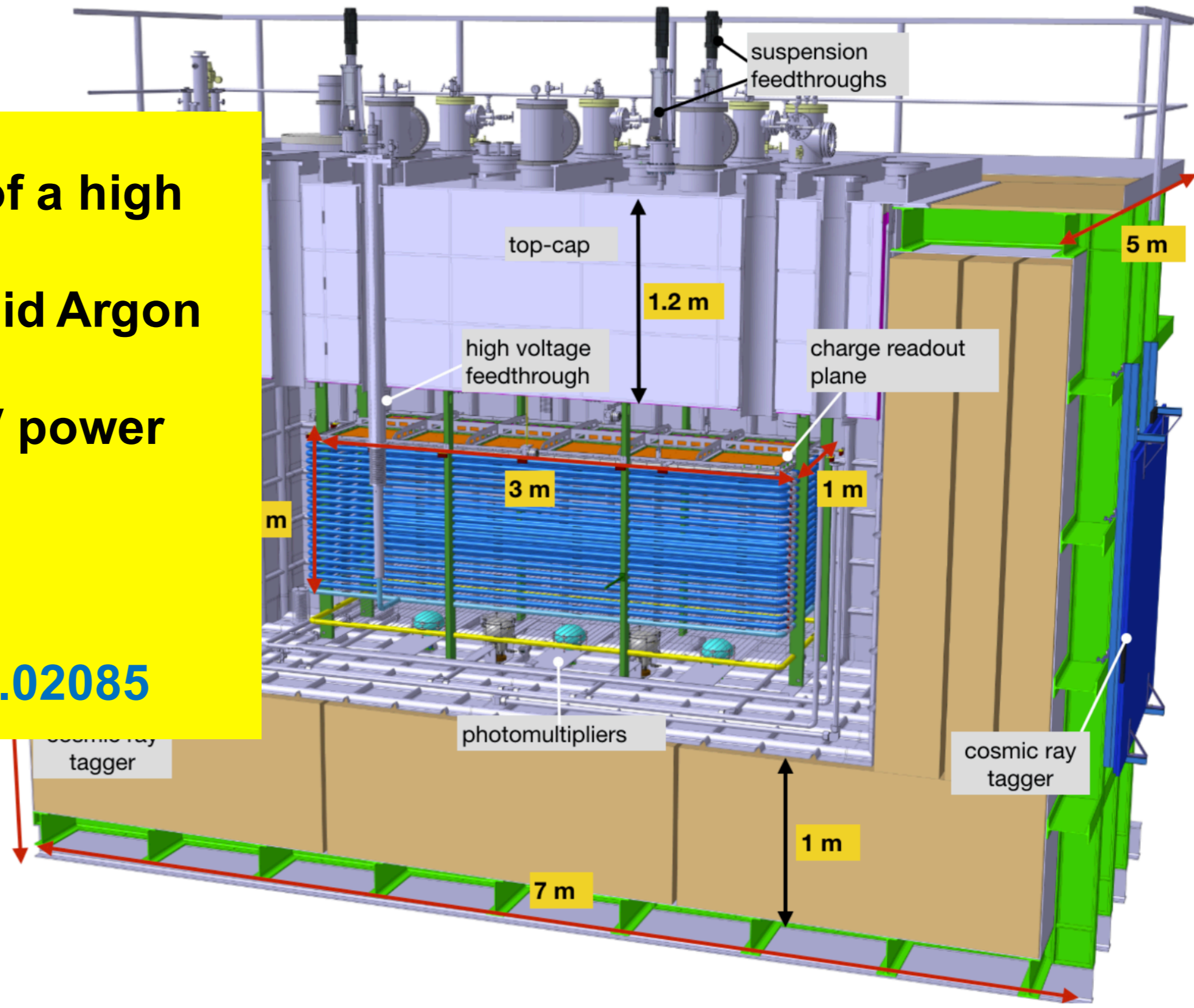

HV cable

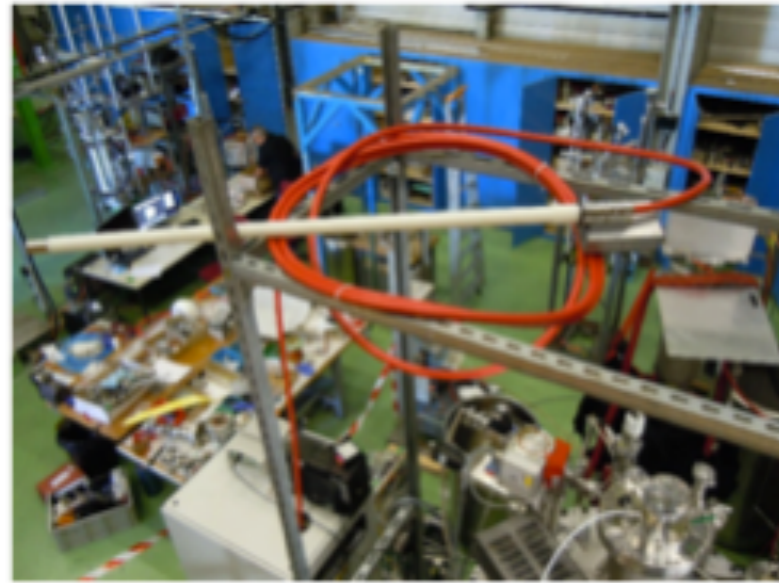

1:1 transformer



HVFT test setup

O₂ impurities gas analyzer precision ±100 ppb

O₂ impurities measured in the gas were less than 0.1 ppm.

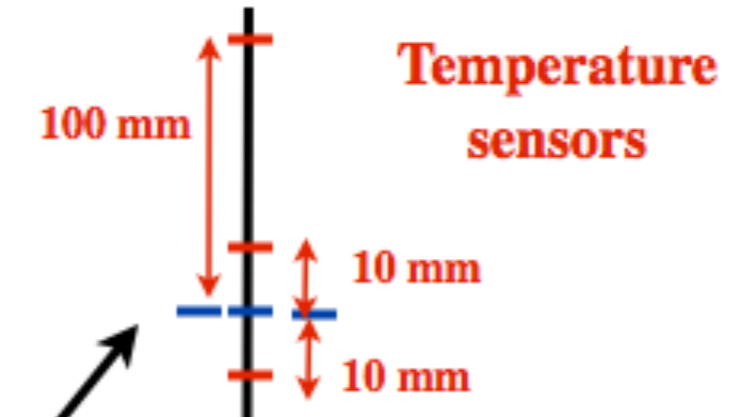
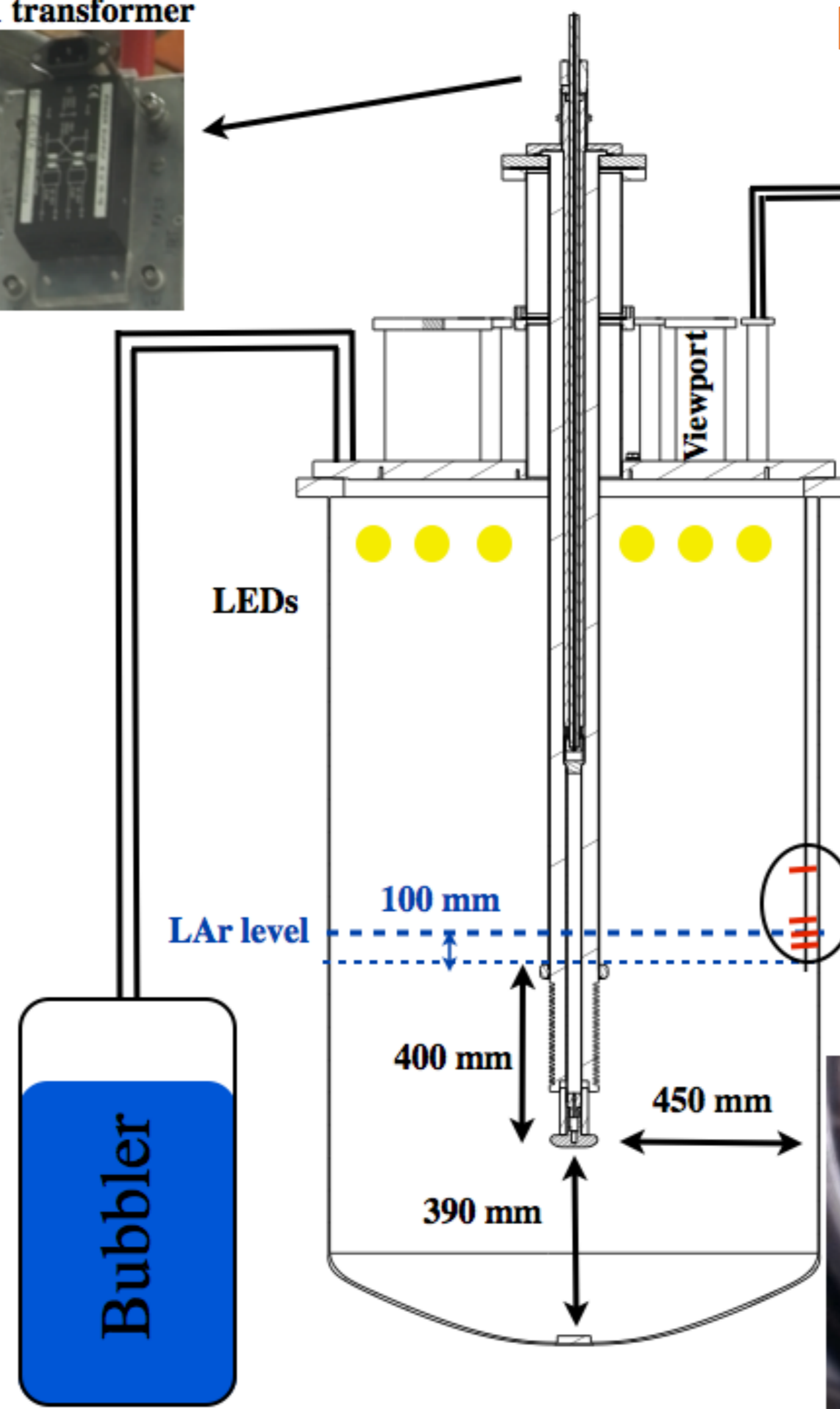

The pressure in the LAr was very stable at 1.05 bar.



Heinzinger

300 kV



Generation of high voltage



PNChp 300000-05-neg Heinzinger power supply (PSU)



Output voltage: approx. 0 up to 300,000 V DC adjustable
Output current: approx. 0 up to 0.5 mA adjustable
Input voltage: 230V 50Hz

Voltage stabilization

Reproducibility: $\leq 0.1\% U_{nom}$
Stability: $\leq 0.001\% U_{nom}$ over 8h
Ripple: $\leq 0.001\%_{pp} U_{nom} \pm 50mV$
Temp. Coefficient: $\leq 0.001\% U_{nom} /K$

Current stabilization

Reproducibility: $\leq 0.1\% I_{nom}$
Stability: $\leq 0.05\% I_{nom}$ over 8h
Ripple: $\leq 0.05\%_{pp} I_{nom} \pm 500\mu A$
Temp. Coefficient: $\leq 0.01\% I_{nom} /K$

Transmission: The HVFT and the HV cable

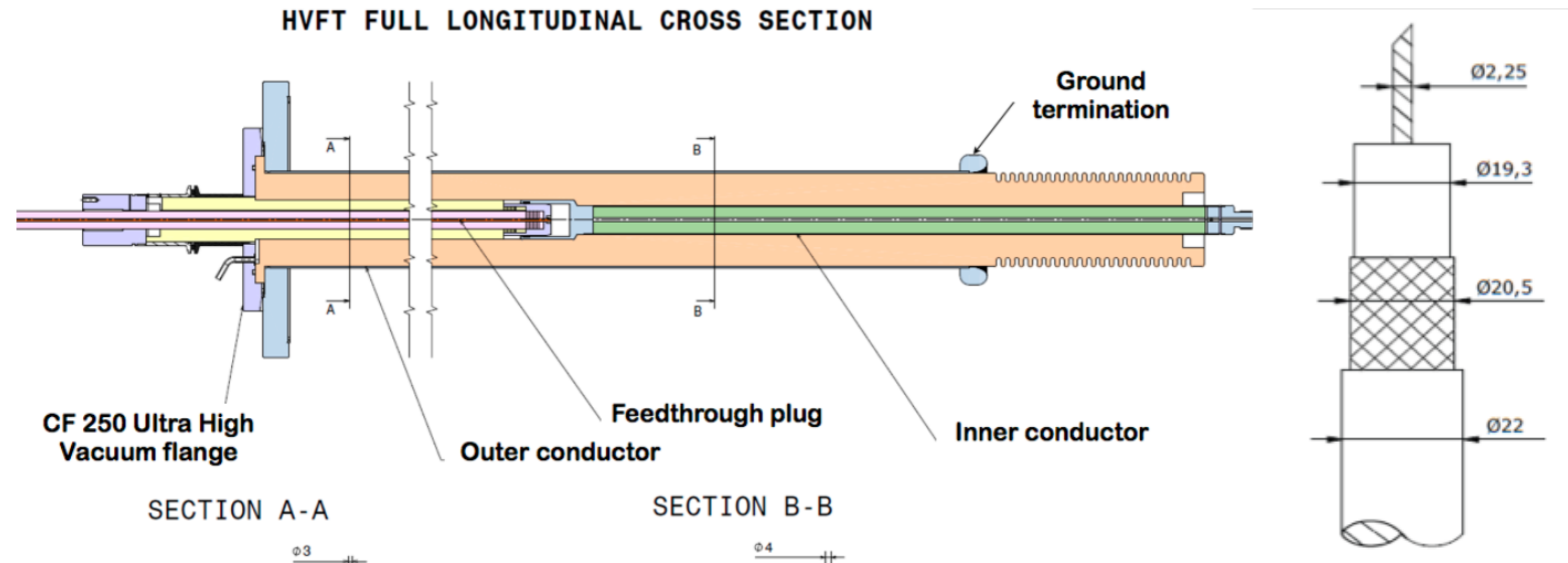

SECTION A-A

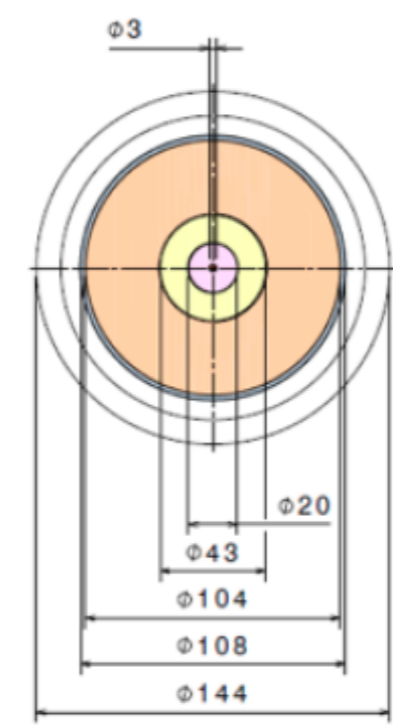

SECTION B-B

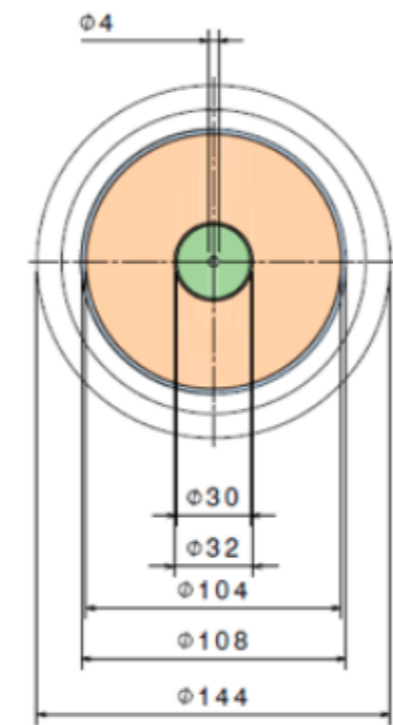

Rated voltage	300 kV
Capacitance	101 pF/m
Inductance	0.3 μ H/m
Center Core	Copper
Dielectric insulator	Polyethylene
Woven copper shield	CuSn
Outer plastic jacket	PVC
Colour	red
Minimum bending radius	440 mm
Temperature resistance up to	60°C

design by Franco Sergiampietri inspired from ICARUS feedthrough

Transmission: The HVFT and the HV cable

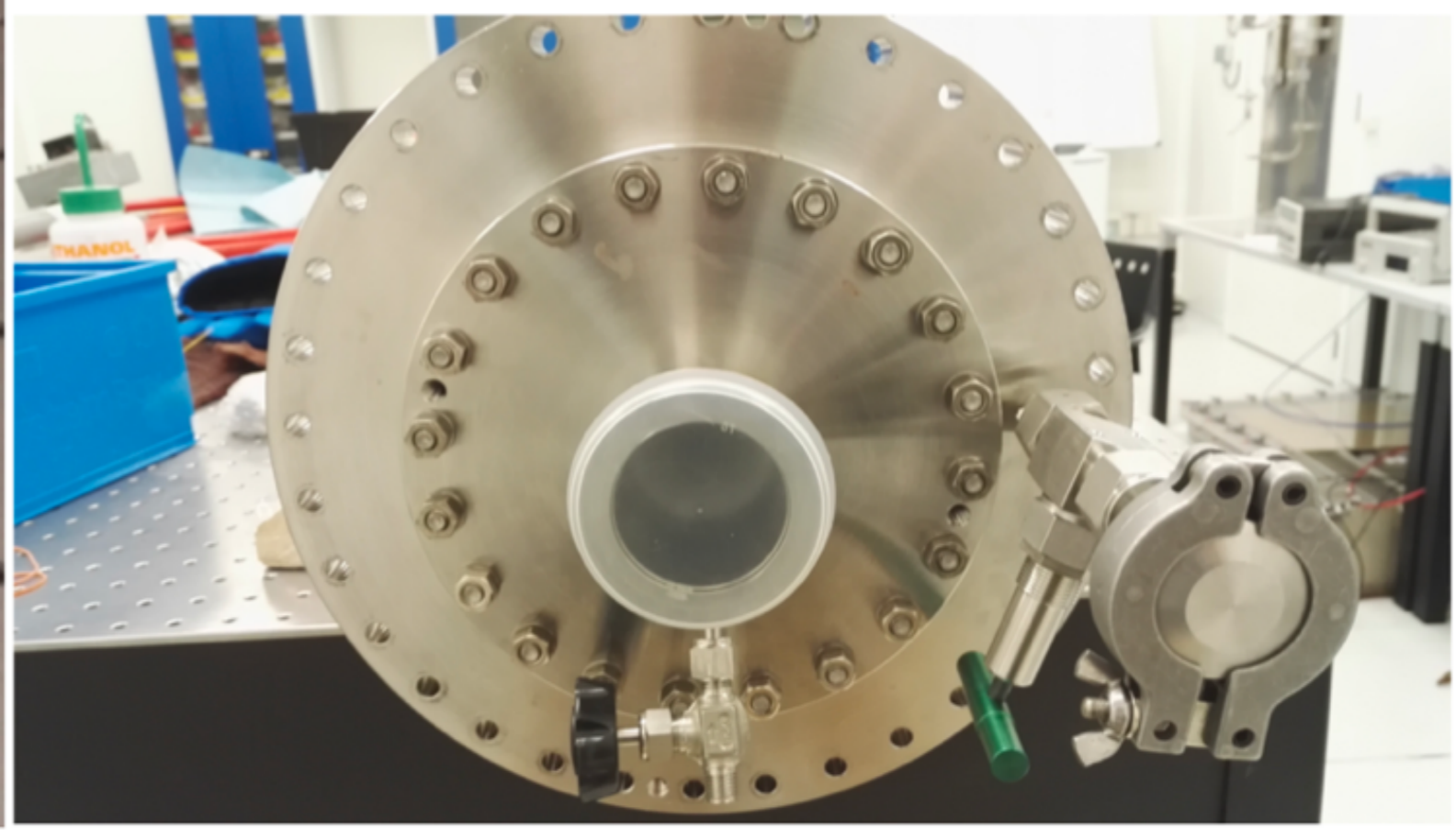
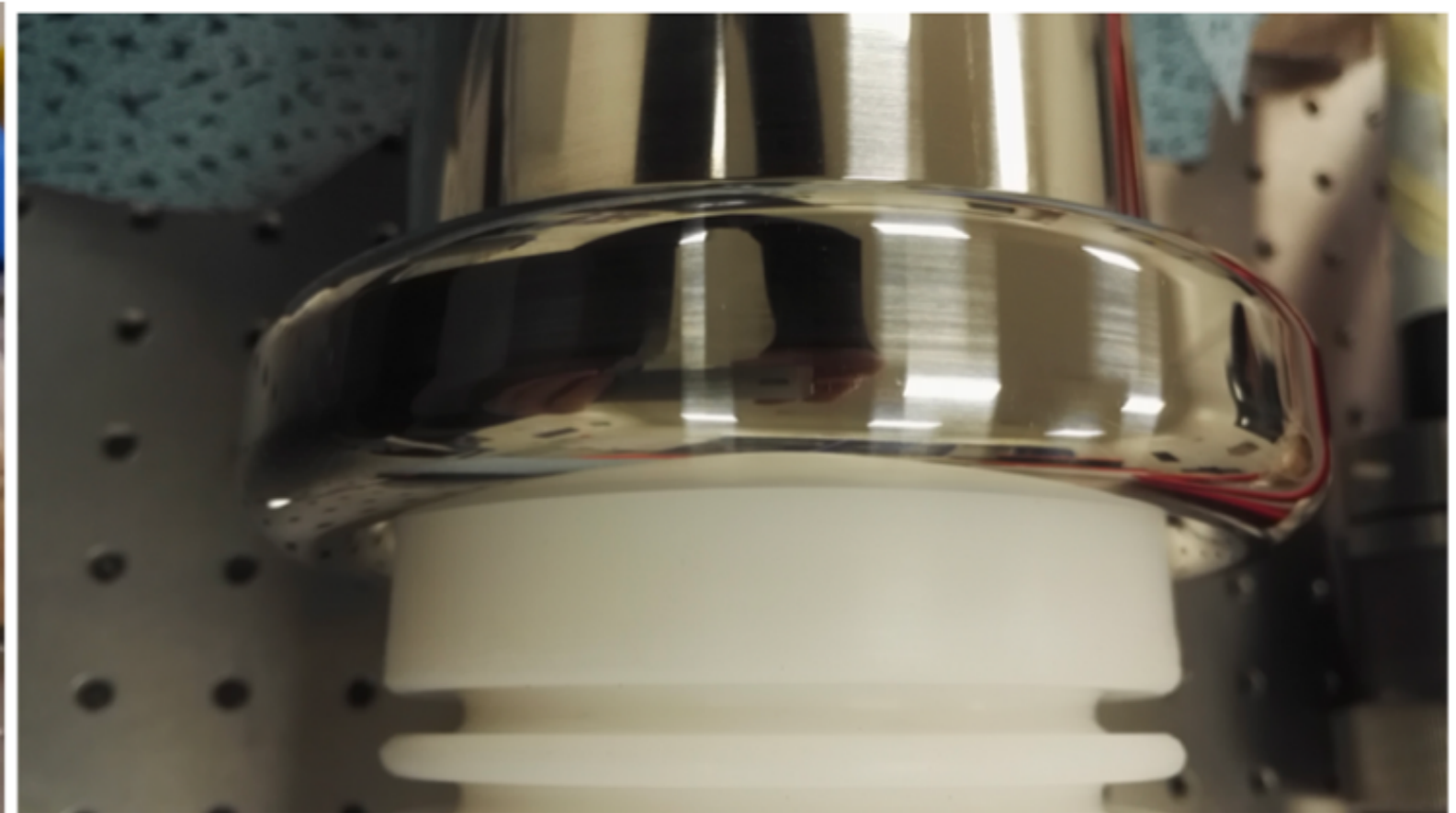

Electrostatic simulations of the HVFT test

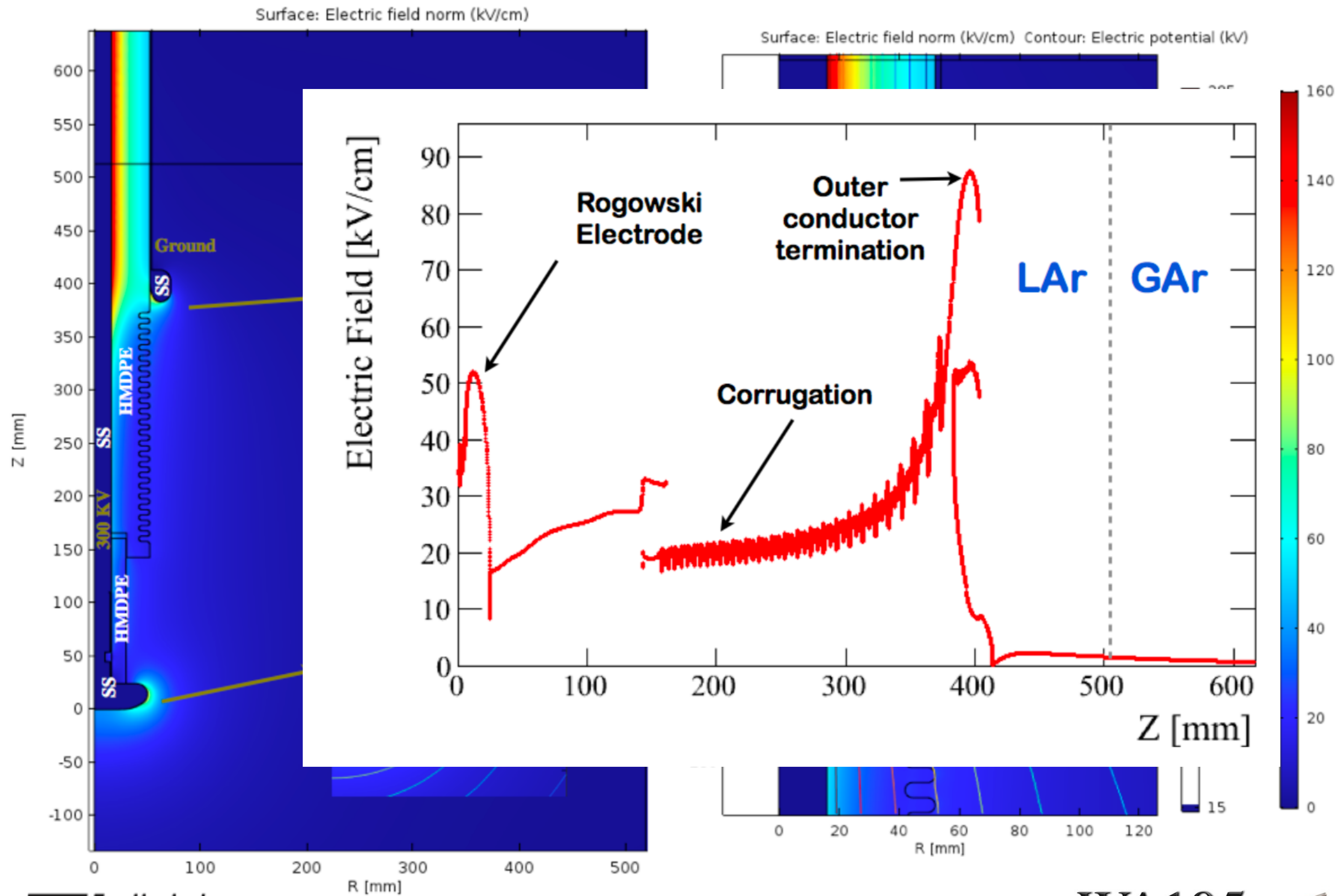

Results of the test

Two series of tests performed during September 2016

1-Ramping up the high voltage while monitoring the current and the voltage

2-Test to understand the stability of the feedthrough during long-term operations

Voltage [kV]	Pressure [bar]	O ₂ impurities in gas [ppm]	Electric field at ground termination [kV/cm]
-275	1.02	< 0.1	80
-250	1.06	< 0.1	73
-100	1.06	< 0.1	29

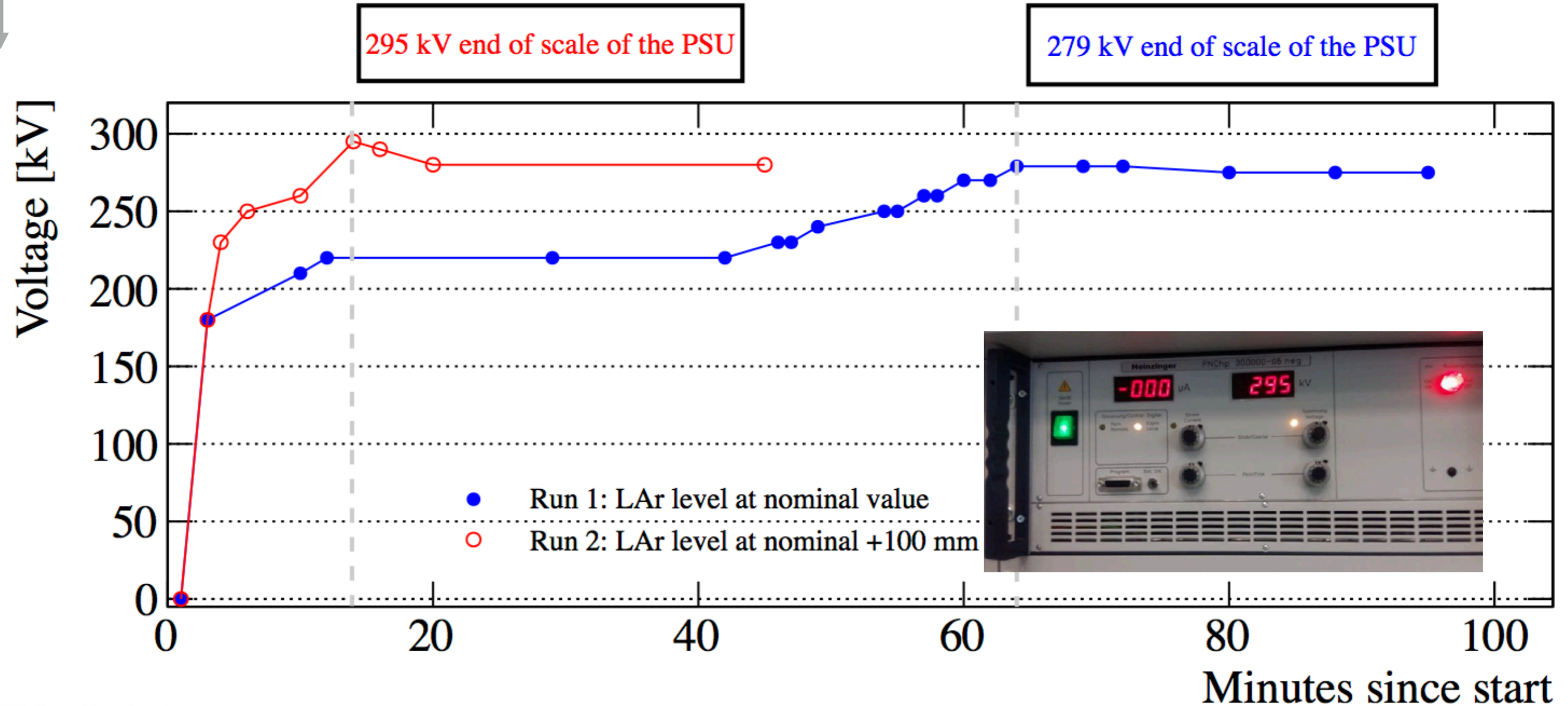

Orders

Offers for the HVFT has been requested to several companies.

One is CINEL Scientific Instruments S.r.l., that already built the HVFT for the 311 DP (40cm shorter): waiting for offers.

Slides from Adamo

- 1 Module have a special connection for the HV degrader
- Full rod (dia 40mm) insert with «cap» of 50mm length machined for cable fixing

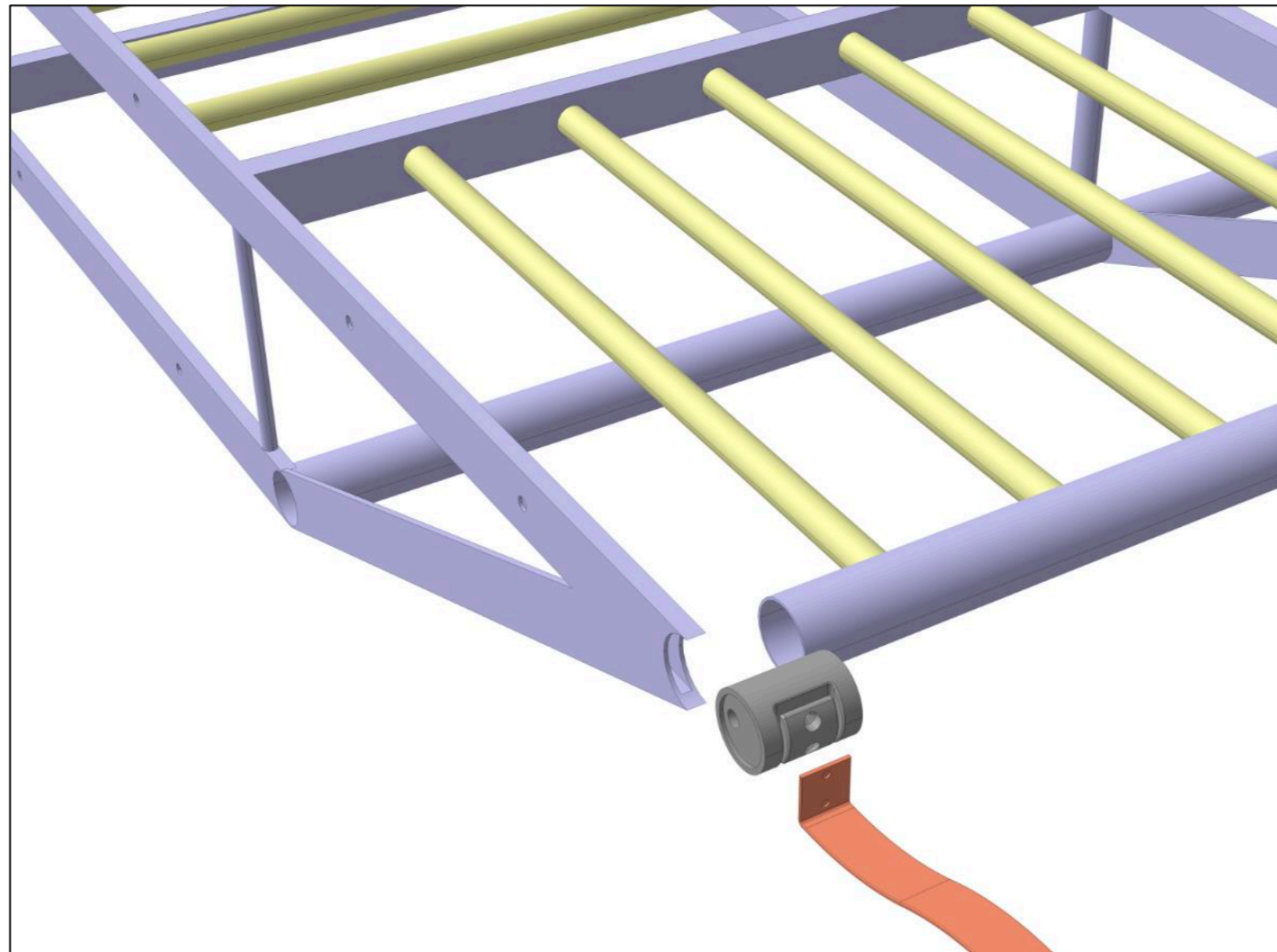

HVFT

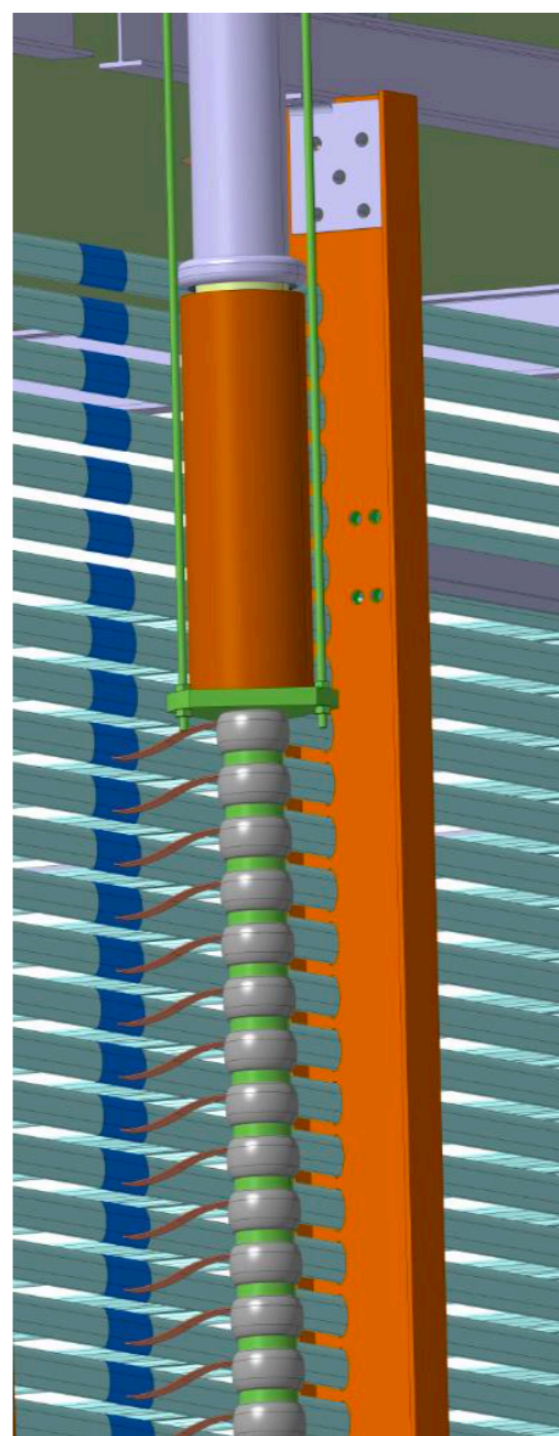

HV degrader

Clip

Alu profile

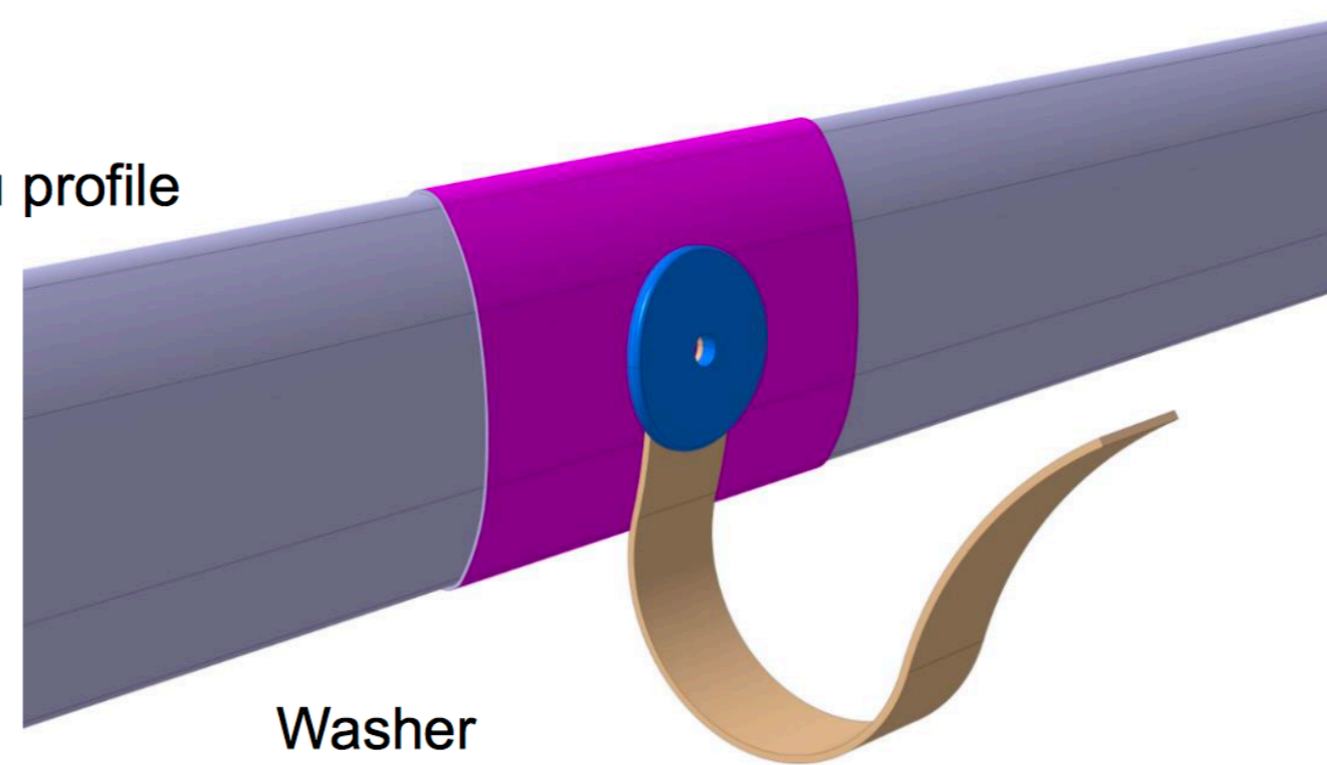

Washer

Cable

See L. Molina Bueno Talk - *HV system design*