

# Cavity and Cryomodule Testing Plan

## SC Acceleration Modules and Cryogenics

Joe Ozelis

PIP-II DOE Independent Project Review

12-14 December 2017

In partnership with:

India/DAE

Italy/INFN

UK/STFC

France/CEA/Irfu, CNRS/IN2P3

## Outline

- Scope of Design and Development
- SRF Test Program Goals
- SSR1/SSR2
  - CM-Specific Components
  - Testing CM-Specific Components
  - Testing CM-Specific Sub-Systems
- HB650/LB650
  - CM-Specific Components
  - Testing CM-Specific Components
  - Testing CM-Specific Sub-Systems
- General CM Risks
- Addressing General CM Risks
- Summary

## About Me:

- PIP-II Manager for Test Infrastructure at Meson Detector Building (STC@MDB)
  - WBS 121.3.21.1
- Sr. Engineering Physicist, joined FNAL in 1989, involved in SRF since 2000
  - Horizontal Test Facility Manager (HTS, STC, HTS-2) (current)
    - Testing, operations, maintenance, upgrades
  - VTS Area Leader (2006-2012)
    - Facility design and construction, operations, maintenance, upgrades, actively conducted 200+ cavity tests
  - Test Facility Coordinator, QA Group Leader (SNS Project @ JLab, 2000-2006)
    - Coordinating VTA and CMTF operations/upgrades, SNS production cavity testing, established SRF QA program for SNS
  - LHC/SSC Magnet Programs (1989-2000)
    - SSC & LHC Magnet performance measurements (quench & mechanical), test system design and implementation, short-sample test facility design/implementation

## Scope Of Design And Development

- PIP-II entails developing and assembling 5 cryomodule types (HWR, SSR1, SSR2, LB650, HB650)
  - HWR is a basic extension of current technology at ANL
    - Limited development program at ANL
    - CM Testing at PIP2IT
  - SSR1/2 and HB/LB650 are new, unique CM designs
  - Require development and verification of new designs for
    - Cavities (incl Helium vessel and magnetic shields)
    - Couplers
    - Tuners
    - Focusing elements (SSR1/2)
    - Cryomodule support, cryogenics, and thermal management systems
- Component, sub-system, and overall CM performance will need to be rigorously verified

## SRF Linac Risks

- Through a comprehensive Risk Analysis exercise, we have identified the top-level (highest) risks associated with the 4 cryomodule types:
  - Pulsed and CW cryomodule operating modes cause cryogenic or mechanical instabilities
  - SSR1/SSR2/LB650/HB650 CM(1) Performance at PIP2IT/CMTF does not meet technical requirements
  - SRF Pre-Production Input Coupler Failure
  - $Q_0$  performance of installed cavities
  - Resonance control

## SRF Test Program Goals

- Within the WBSs for the 4 CM types are numerous activities associated with design verification of components and sub-systems, and qualification of production components.
  - These activities are integrated in the P6 schedule, with resources assigned.
  - Except for production qualification, they typically precede final design activities and production procurements.
- Each WBS also includes comprehensive testing of “1<sup>st</sup> CMs” for all CM types, followed by production testing of all cryomodules.
  - These activities are also integrated into P6, with resources assigned.
  - This is the final activity that addresses “global” CM performance risks.
- The Test Program addresses performance risks from the component to sub-system to final integrated CM level.

# Testing Hierarchy

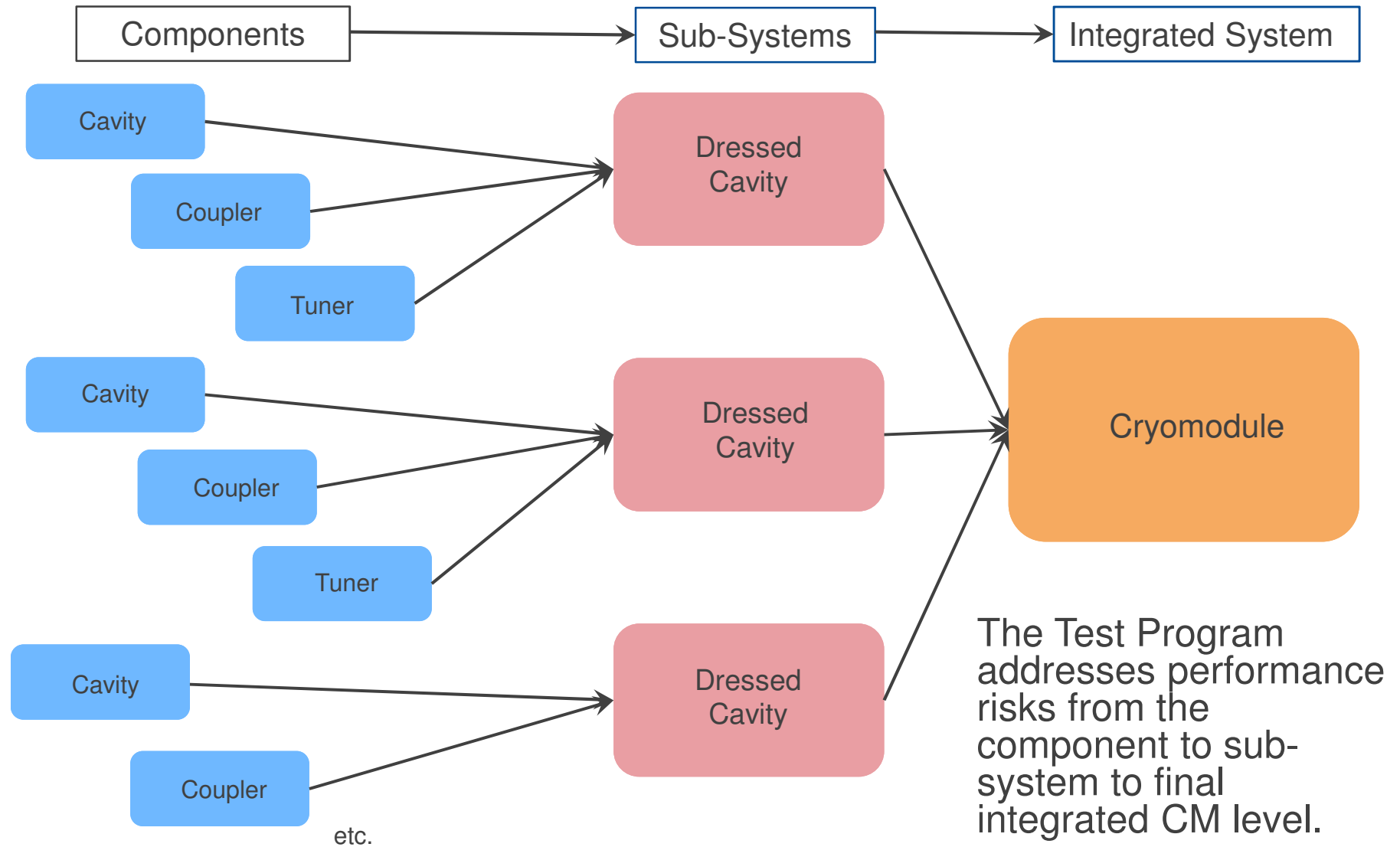

## CM-Specific Components – SSR1/SSR2

- Cavities
  - SSR1 bare & jacketed/dressed cavity design verified (VTS/STC), but minor design upgrade underway for CM#2
  - SSR2 cavity new design, will require complete testing/verification of bare and jacketed cavities in the VTS (and then STC)
  - MP and FE are of concern for all SSR1/SSR2 cavities
- Couplers
  - Prototype and pre-Production couplers tested in RT test stand and in STC w/ cavity
    - Design meets performance goals for SSR1
  - Still need to test production couplers
    - Verify vendor manufacturing processes, reliability
    - Verify meets performance requirements for SSR2



## CM-Specific Components – SSR1/SSR2

- Tuner/Resonance control
  - Prototype and production tuner design bench tested and tested on dressed SSR1 cavity in STC.
    - Prototype used for extended resonance control studies
    - Production tuner now being used in STC testing for additional further resonance control studies on SSR1 cavities.
  - Resonance control pushes state-of-the-art
- Focusing Elements (solenoids)
  - Prototype solenoids for SSR1 #1 tested in SC Magnet Test Facility (IB1)
    - LHe bath
  - Current leads need to be tested (current capacity, heat load)
    - Using HWR CM style leads
      - Established technology

# Testing CM-Specific Components – SSR1/SSR2

- Bare Cavities
  - Updated SSR1 cavity design for CM#2 will be tested bare in VTS
    - All 9 cavities to be tested bare in VTS
    - All 9 cavities to be tested jacketed (w/He vessels) in VTS
  - SSR2 cavity new design
    - 2 prototype cavities built for FNAL, 2 prototype cavities built by DAE
      - All (4) prototypes tested bare at FNAL VTS
        - 3 process/test cycles/cavity for FNAL cavities in schedule
      - All (4) prototypes tested jacketed at FNAL VTS
    - 4 pre-production cavities built for FNAL
      - All (4) pre-production cavities tested bare at FNAL VTS
      - All (4) pre-production cavities tested jacketed at FNAL VTS
  - SSR2 production cavities
    - All jacketed production cavities tested in VTS (FNAL and DAE supplied)
      - A 40% re-process/re-test fraction is included in P6 planning



SSR1 cavity – VTS test

# Testing CM-Specific Components – SSR1/SSR2

- Couplers
  - Couplers for SSR1 CM#1/CM#2
    - All CM#1 couplers tested on room-temperature test stand after initial QA/QC
    - Testing sub-set for CM#1 on dressed cavities in STC (cavity qualification for SSR1 CM#1)
      - Couplers for CM#2 ordered after these tests (and any design updates)
    - All CM#2 couplers tested on room-temperature test stand after initial QA/QC
    - Testing 2 couplers for CM#2 on dressed cavities in STC
  - A set of SSR1 Couplers have been tested on test stand to SSR2 spec (30kW)
    - One tested to failure at 47kW (50% above spec)



RT Test Stand

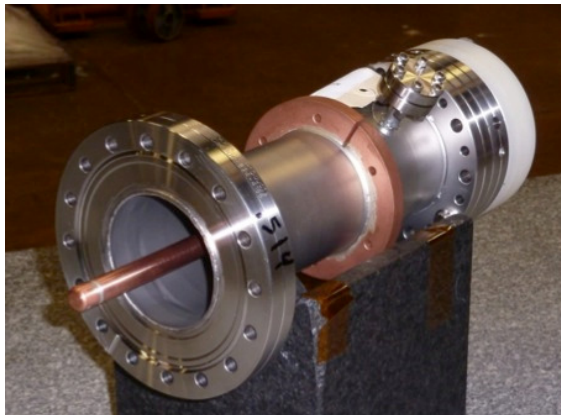

325MHz Coupler – cold end

- 2 Prototype SSR2 couplers to be procured
  - Tested on room-temperature test stand after initial QA/QC
  - Tested on (2) prototype cavities in STC
  - 6 Pre-production couplers to be procured
  - After tests of prototypes in STC
  - All tested on room-temperature test stand after initial QA/QC
- Testing of 2 pre-production couplers with pre-production dressed cavities in STC

## Testing CM-Specific Components – SSR1/SSR2

- Tuner/Resonance control
  - SSR1 CM#2 tuners ordered after testing of SSR1 CM#1 tuners in STC
  - Continued testing of SSR1 CM#1 cavities with tuners allow for additional resonance controls studies
  - Pre-production tuners for SSR2 (based on SSR1) design ordered after tests in STC of SSR1 production tuners
  - Production tuners for SSR2 ordered after tests of SSR2 prototype cavities and pre-production tuners in STC
  
- Focusing Elements (solenoids)
  - 4 Solenoids for SSR1 #2 will be tested in SC Magnet Test Facility (IB1) in like manner as those for SSR1 CM#1
  - Current leads undergo QA/QC upon receipt
  - SSR2 solenoids undergo incoming QA/QC followed by testing in SC Magnet Test Facility

SSR1 Cavity with Tuner in STC

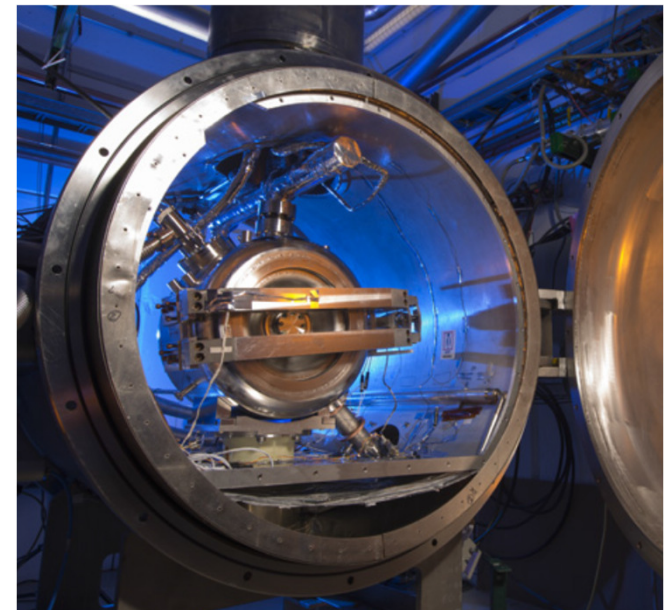

## Testing CM-Specific Sub-Systems – SSR1/SSR2

- Sub-System tests with dressed cavities (cavity/HeV/tuner/coupler) are also planned, as part of system and extended component design verification.
  - Incorporated into P6 schedule with adequate durations
  - Using prototype or “first-article”/pre-production components
  - Serve as “gatekeeper” to FDR or PRR

- Uses existing STC facility & ancillaries

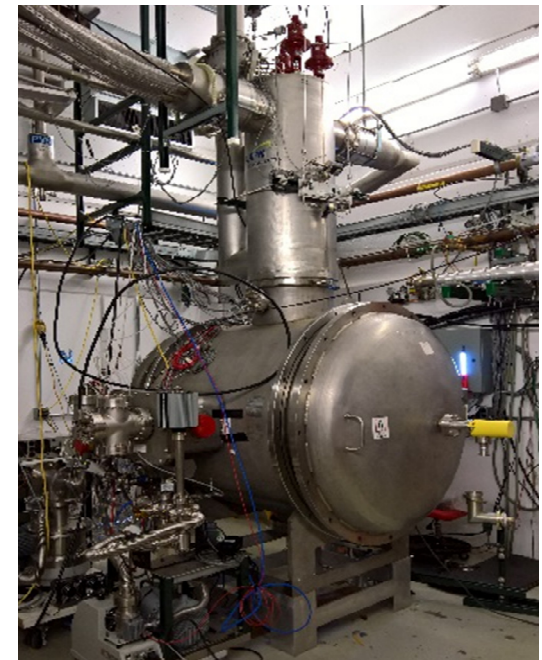
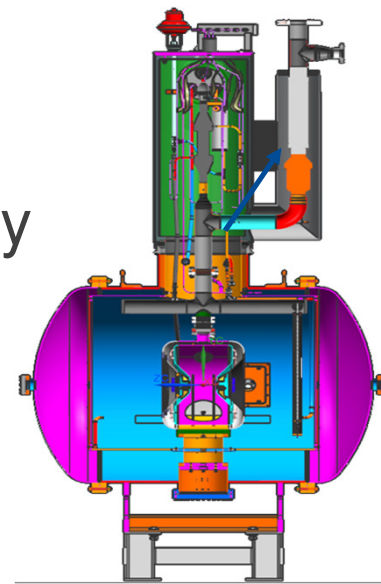

## Testing CM-Specific Sub-Systems – SSR1/SSR2

- STC test program:
  - SSR1 CM#1 Dressed cavities and prod couplers/tuners (4)
    - Qualification testing – 2 weeks cold testing (1 week RC studies)
  - SSR1 CM#1 Dressed cavities and prod couplers/tuners (2)
    - Qualification/vendor production testing – 5 weeks cold testing
  - SSR2 Prototype dressed cavities and prot tuner/coupler (2 FNAL, 2 DAE)
    - Design verification testing – 7-8 weeks cold testing
  - SSR2 Pre-production dressed cavities and pre-prod tuner/coupler (2)
    - Design verification/vendor qualification testing – 4-7 weeks cold testing
  - SSR2 Production dressed cavities and prod tuner/coupler (3 DAE, 2 FNAL)
    - Qualification/vendor production testing – up to 4 weeks cold testing
- A total of 15 STC test cycles for ~80 “cold weeks” for SSR1/SSR2

## CM-Specific Components – HB650 (LB650)

- The SRF Test Program for elliptical cavities is focused on the requirements of the HB650 CM. The LB650 CM development (where not identical to HB650) is the responsibility of International Partners (with close FNAL involvement).
- Bare Cavities
  - HB650 cavity design ( $\beta=0.92$ ) is new
    - 2 prototype cavities to be fabricated by vendor
    - Cavity  $Q_0$  ( $r_s$ ) specification requires N-doping recipe similar to LCLS-II
      - Flux expulsion (fast cooldown) & magnetic shielding will be critical
      - Recipe being developed using existing  $\beta=0.90$  cavities for CM#1
  - LB650 cavity design ( $\beta=0.61$ ) is new
    - Prototypes will be fabricated by partner labs
    - Similar stringent requirements on  $Q_0$  ( $r_s$ ) : N-doping, flux expulsion, magnetic shielding
      - Adopt HB650 processing recipe for LB650
      - Utilize similar (identical) magnetic shielding and flux-expulsion techniques
  - FE-free performance requires optimization of HPR tools
  - Tight tolerance on microphonics and LFD bandwidth requires advanced resonance control techniques.

## CM-Specific Components – HB650 (LB650)

- Couplers
  - New coupler design : coaxial, 650MHz, 120kW (suitable for both HB/LB CMs)
    - Two cold end designs being prototyped
    - Prototypes to be evaluated on RT test stand and also in STC tests with  $\beta=0.90$  cavities
  - Verification of RF (power), thermal, and vacuum performance required before pre-production/production procurement
- Tuner/Resonance control
  - Tuner design based on LCLS-II tuner, suitable for both HB/LB cryomodules (with slight adaptation); prototype received and bench tested.
    - Design being refined
    - Cryogenic operation to be evaluated during STC tests with  $\beta=0.90$  cavities
  - Resonance control to be studied during all STC testing, no experience yet in achieving required specifications



# Testing CM-Specific Components – HB650

- Bare Cavities
  - HB650 cavity new design ( $\beta=0.92$ )
    - 2 prototype cavities built for FNAL
      - Tested bare at FNAL VTS
        - 3 process/test cycles/cavity in schedule
        - Use N-doping/processing recipe developed for  $\beta=0.90$  cavities as baseline
        - HPR tooling to be optimized
      - Tested jacketed at FNAL VTS
    - 4 prototype cavities being fabricated and jacketed by DAE
      - Tested jacketed at FNAL VTS (tested bare (VTS) & dressed (HTS) by DAE)
  - HB650 production cavities (10)
    - Production cavities supplied by FNAL tested bare in VTS
    - Production cavities supplied by FNAL tested jacketed in VTS
      - A 40% re-process/re-test fraction is included in P6 planning in both cases
  - HB650 cavity old design ( $\beta=0.90$ )
    - 1 more bare cavity to be tested in VTS
    - 4 jacketed cavities to be tested in the VTS

650MHz  
 $\beta=0.90$  Cavity  
 in HPR Tool

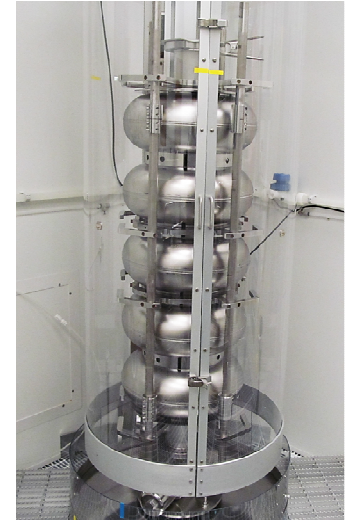

# Testing CM-Specific Components – HB650 (LB650)

- Couplers
  - 4 Prototype HB650 coupler cold-ends have been procured
    - Two of each (cold end) design, two “universal” warm ends
    - Tested on room-temperature test stand after initial QA/QC
    - Tested on first 2  $\beta=0.90$  cavities in STC
      - One of each kind, unless RT testing indicates otherwise
  - 8 Pre-production couplers to be procured
    - After initial tests of prototypes in STC
    - All tested on room-temperature test stand after initial QA/QC
    - Tested on two remaining  $\beta=0.90$  cavities in STC
    - Tested on two prototype  $\beta=0.92$  cavities in STC

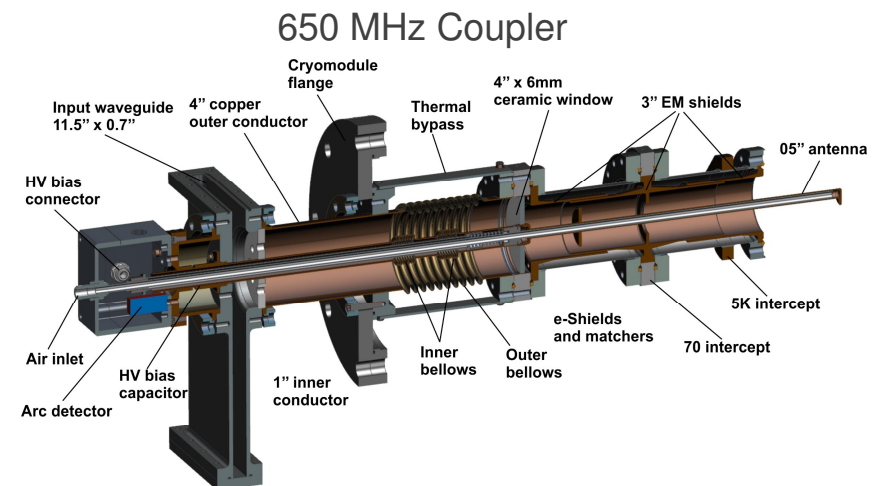

## Testing CM-Specific Components – HB650 (LB650)

- Tuner/Resonance control
  - 1<sup>st</sup> (upgraded) prototype to be tested in STC using  $\beta=0.90$  cavities
  - 4 “production” tuners for  $\beta=0.90$  cavities and 3 “production” tuners for  $\beta=0.92$  cavities ordered after prototype tested in STC
    - tested with  $\beta=0.90$  and  $\beta=0.92$  cavities in STC
      - $\beta=0.90$  cavities used on CM#1
  - 10 production tuners for CMs 2-4 ordered after prototypes and early “production” tuners tested and CM#1 tested at CMTF.
  - Resonance control studies part of all extended (design verification) STC testing with  $\beta=0.90$  and  $\beta=0.92$  cavities
  - Tuner motor and piezo lifetime tests planned as part of “bench-testing”

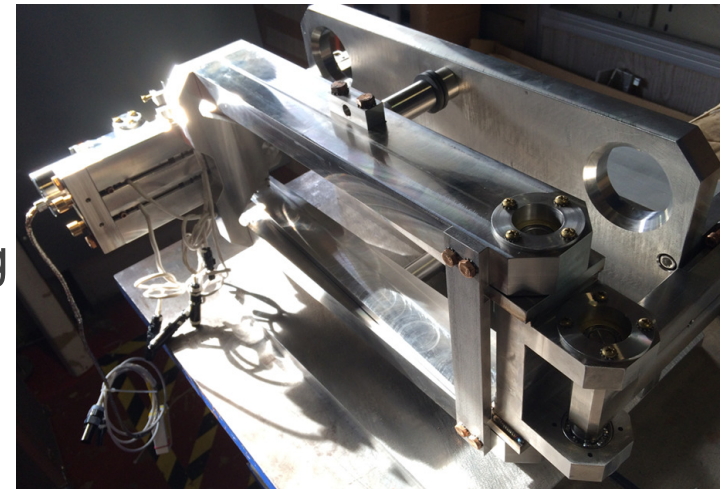

650 MHz Prototype Tuner V. 1

## Testing CM-Specific Sub-Systems – HB650

- Sub-System tests with dressed cavities (cavity + HeV + tuner + coupler) are also planned, as part of system design verification.
  - Incorporated into P6 schedule with adequate durations
  - Multiple iterations
  - Using prototype or “first-article”/pre-production components
  - Serve as “gatekeeper” to FDR or PRR
- Use modified (extended) STC facility & ancillaries

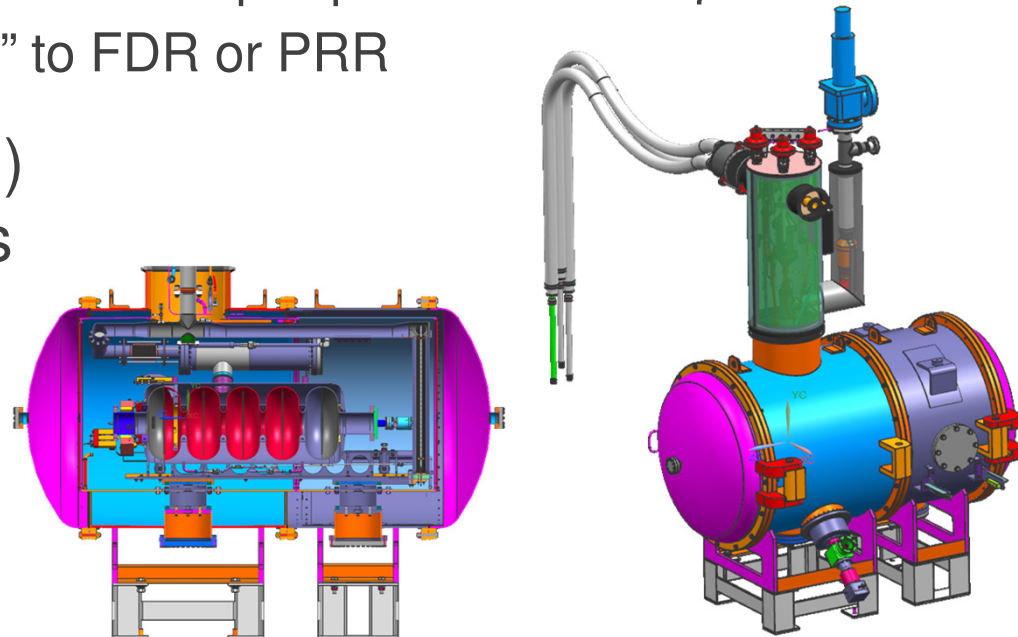

## Testing CM-Specific Sub-Systems – HB650

- STC test program:
  - HB650 CM#1  $\beta=0.90$  cavities (4) tested in STC with prototype and pre-production couplers/tuners
    - Design verification testing – 8 weeks cold testing cavities 1,2; 5 weeks cold testing cavities 3, 4
      - This allows multiple (fast) cooldowns, coupler thermal studies, extended resonance control studies
  - HB650 prototype  $\beta=0.92$  cavities (2) with pre-production couplers/tuners
    - Design verification testing – 8 weeks cold testing
      - This allows multiple (fast) cooldowns, coupler thermal studies, extended resonance control studies
  - HB650 production dressed cavities and prod tuner/coupler (2, supplied by FNAL)
    - Qualification/vendor production testing – up to 4 weeks cold testing
- A total of 8 STC test cycles for ~50 “cold weeks”, for HB650

## General CM Risks – SSR1/SSR2/LB650/HB650

- In addition to the specific challenges related to cryomodule components, there remain the overall cryomodule performance risks :
  - Pulsed and CW cryomodule operating modes may lead to cryogenic or mechanical instabilities
    - Increases difficulty of resonance control due to enhanced microphonics
  - CM(1) Performance at PIP2IT/CMTS may not meet technical requirements
    - CM might not achieve performance necessary to operate in the Linac
  - $Q_0$  performance of installed cavities
    - Increased CM heat load, especially in CW operating
  - Resonance control
    - Greater difficulty in operating cavities in phase/on frequency, more difficult to compensate LFD in pulsed mode

# Addressing General CM Risks

- Comprehensive testing of cryomodules addresses global CM performance risks documented in the Risk Register, and also provides design verification of CM support, thermal, and cryogenic structures, that can not be otherwise evaluated.
- HB650/LB650/SSR1/SSR2 CM#1s are extensively tested in the CMTS or PIP2IT facilities.

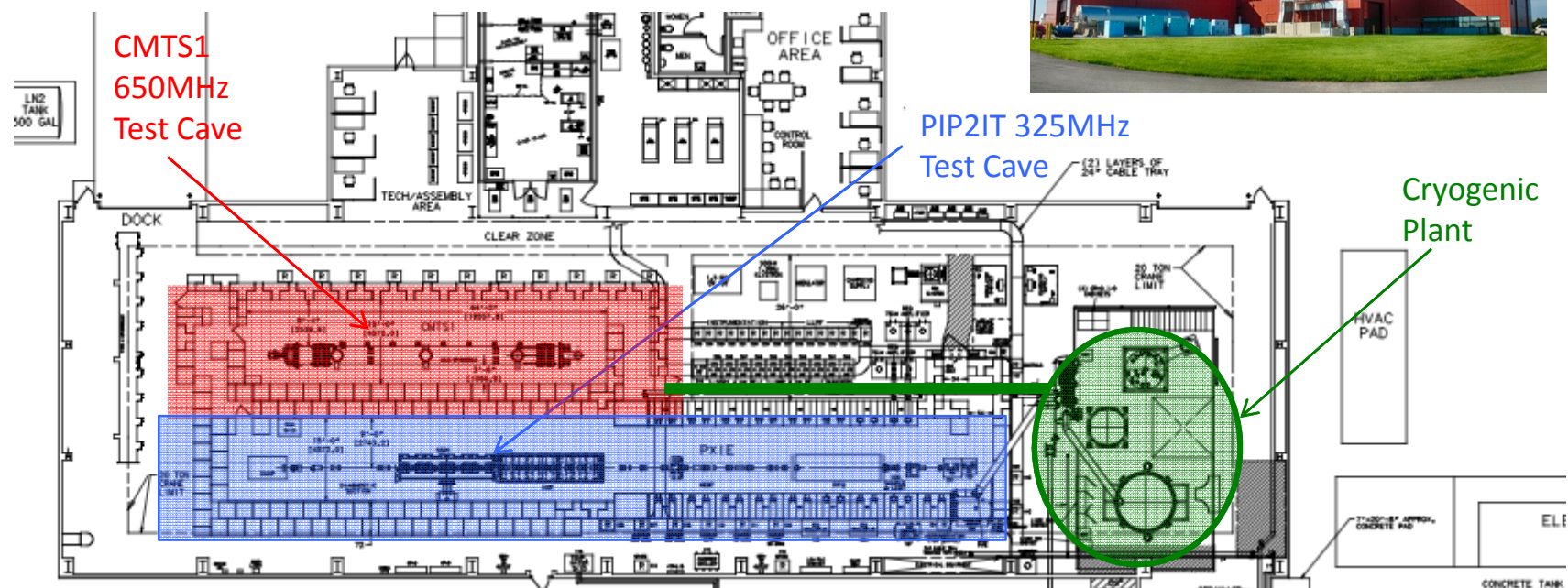

## Addressing General CM Risks

- HB650/LB650/SSR1/SSR2 CM#1s are extensively tested in the CMTS or PIP2IT facilities.
  - A test plan using lessons-learned from LCLS-II pCM testing will be developed for CM#1s
    - Two months (60 calendar days) of cold testing is planned in P6 for each 1<sup>st</sup> CM type.
      - Additional time for installation, checkout, preparation, and cooldown are included, based on experience with LCLS-II pCM
      - Multiple cooldown cycles (“fast cooldowns”, where appropriate)
      - Extensive diagnostics
      - Performance feedback to inform Final Design efforts, precursor to FDR/PRR
- Production cryomodules (SSR12 #2, SSR2 #2-7, HB650 CM#2-4, LB650 CM#2-11) are also fully tested in CMTS.
  - Test durations from 16-8 days (decreasing with later production)



## Summary

- A comprehensive “Test Program” designed to
  - evaluate prototype designs
    - provide feedback to production design
  - qualify production components
    - provide feedback to vendors
  - validate sub-system performance
    - provide feedback to design and assembly teams
  - qualify overall cryomodule design/performance
    - provide feedback to assembly and commissioning teams

has been fully integrated into the WBS structure for the SRF Linac in the P6 schedule

  - Labor efforts and M&S for these activities are included in our project planning
- The successful pursuit of these activities is the responsibility of the respective L3 managers
- These activities are designed to retire the risks associated with cryomodule performance in the Linac.

**END**

# BACKUP SLIDES