



Construction Status of the FRIB Lithium Charge Stripper

T. Kanemura^a, F. Marti^a, M. LaVere^a, R. Madendorp^a,
and Y. Momozaki^{a,b}

^aFacility for Rare Isotope Beams, Michigan State University

^bArgonne National Laboratory

MICHIGAN STATE
UNIVERSITY



U.S. DEPARTMENT OF
ENERGY

Office of
Science

Outline

- What is FRIB?
- Charge strippers at FRIB
- Approach to FRIB lithium charge stripper development
- Technical challenge and hazard mitigation for lithium stripper development
 - Development of electromagnetic pump
 - Mitigation of lithium related hazards
- Latest status
- Future work
- Summary



What is FRIB?

- The **Facility for Rare Isotope Beams (FRIB)** is funded by U.S. Department of Energy–Office of Science–Nuclear Physics with contributions and cost share from Michigan State University
- Facility performance expectations
 - Rare isotope production with primary beams up to 400 kW, 200 MeV/u uranium
 - Fast, stopped and reaccelerated beam capability
 - Experimental areas and scientific instrumentation for fast, stopped and reaccelerated beams
 - World-class science on day one

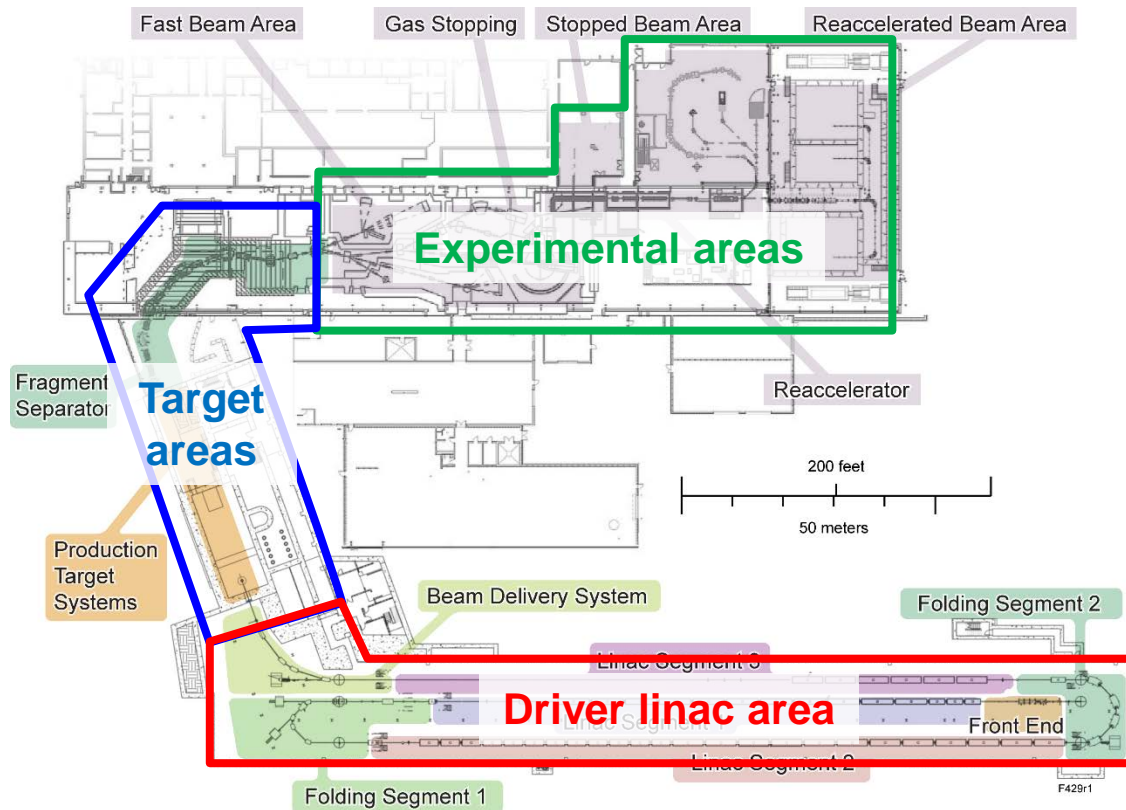

Charge Strippers at FRIB

Baseline Choice: Liquid Lithium

Charge strippers at FRIB

- Carbon stripper
 - » Solid carbon foils for beam commissioning (low intensity beams)
- Liquid lithium stripper: baseline choice
 - » For high intensity beams
 - » Doesn't suffer radiation damage to the material lattice and can remove heat quickly
 - » Relatively low melting point (181 °C), low vapor pressure at that temperature ($\sim 10^{-8}$ Pa), high boiling point (1342 °C), high heat capacity and low viscosity.
 - » Reactive with air. Safety concerns. Hazard mitigation required.

Beam parameters at stripper for full-power (400 kW) uranium beam

- $E = 16 \sim 20$ MeV/u
- $P_{\text{beam}} = \sim 40$ kW
- $P_{\text{deposited}} = \sim 0.6$ kW
- $\sigma_{x \text{ beam}} = \sim 0.75$ mm
- $\sigma_{y \text{ beam}} = \sim 0.75$ mm
- $P = \sim 8.5$ MW/cm³
- Charge state=
 - » Before 33+ and 34+
 - » After 76+ to 80+

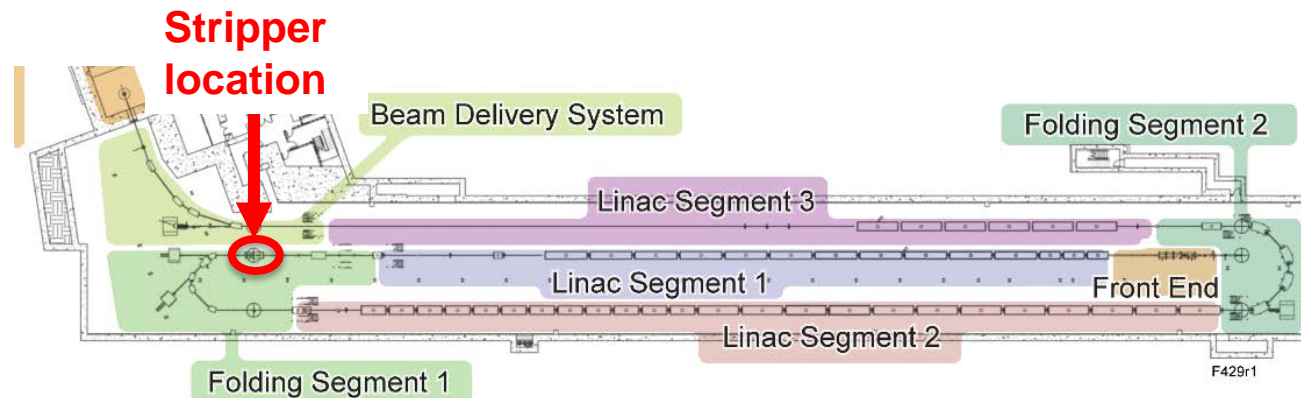

Approach to Lithium Charge Stripper Established

- **Prototype lithium stripper for feasibility demonstration: 2005 – 2013**
 - Establishment of lithium film and thickness control at ANL: December 2010
 - Restoration of Low Energy Demonstration Accelerator (LEDA) proton source for lithium stripper test: 2013
 - Full (2X) power density test of lithium with proton beam at ANL: April 2013
- **Fabrication of lithium stripper system 2013 – 2017**
 - Liquid stripper lithium electromagnetic pump test: April 2017
 - Integrated controls test with Ar safety system: October 2017
 - Lithium charge stripper device assembled: December 2017
- **Offline test outside of the FRIB linac tunnel: 2018 – 2020**
 - Lithium loaded into the system: May 2018
 - Lithium charged into the loop: August 2018
 - Lithium circulated with the electromagnetic pump: August 2018
 - Continuous operation for an extended period, stable film production
- **Online beam commissioning: 2020 –**
 - Integrated test with beam chamber connected
 - Likely improvements based on lessons learned



I joined the Lab Sep. 2016 from the IFMIF project (Li target development).

Scope of Equipment in Offline Test Site

Offline Test Without Connection to the Beam Line

■ Lithium stripper module in Offline test site configuration includes

- Lithium loop
- Secondary vessel, lithium loop inside
- Vacuum system
- Argon system
- Exhaust line
- Controls

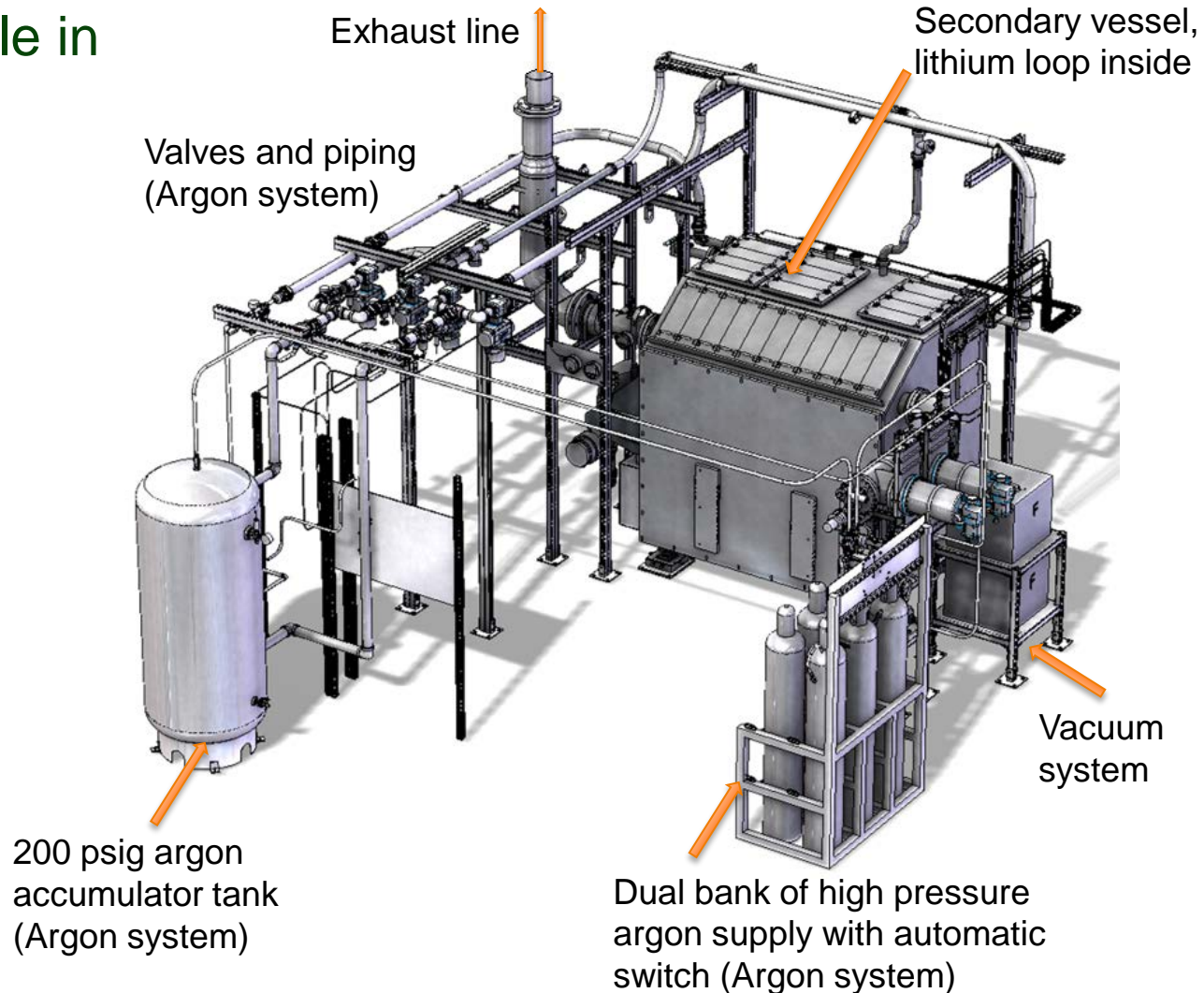

Double Enclosure for Hazard Mitigation

Primary Lithium Loop Enclosed by Secondary Vessel with Ar Fill

- Secondary vessel encloses the entire Li loop and provides an inert gas safety barrier. The vessel atmosphere is maintained as an argon environment during operation (i.e. when Li is not solid)

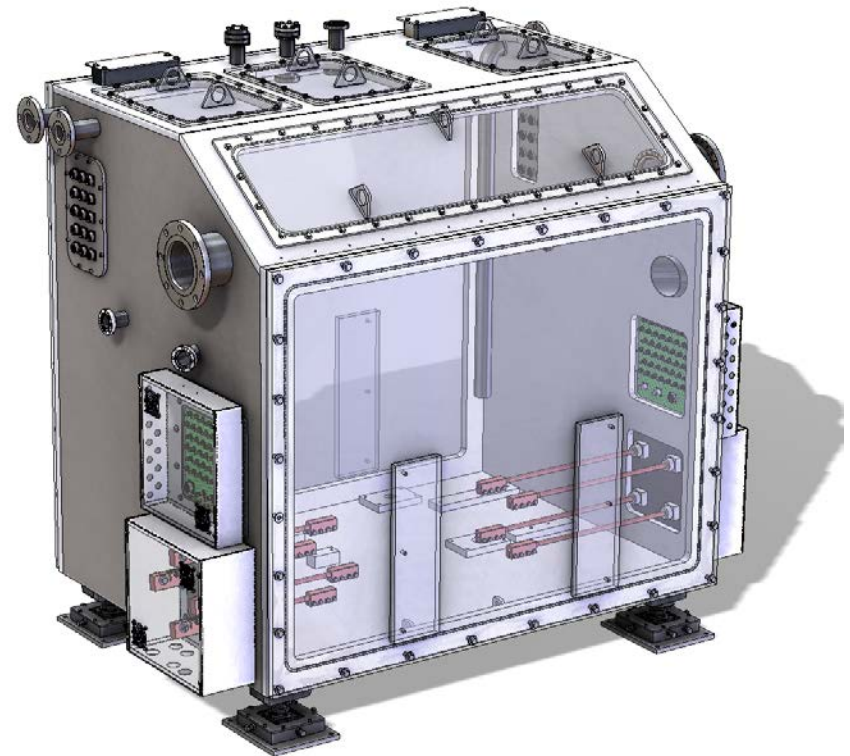
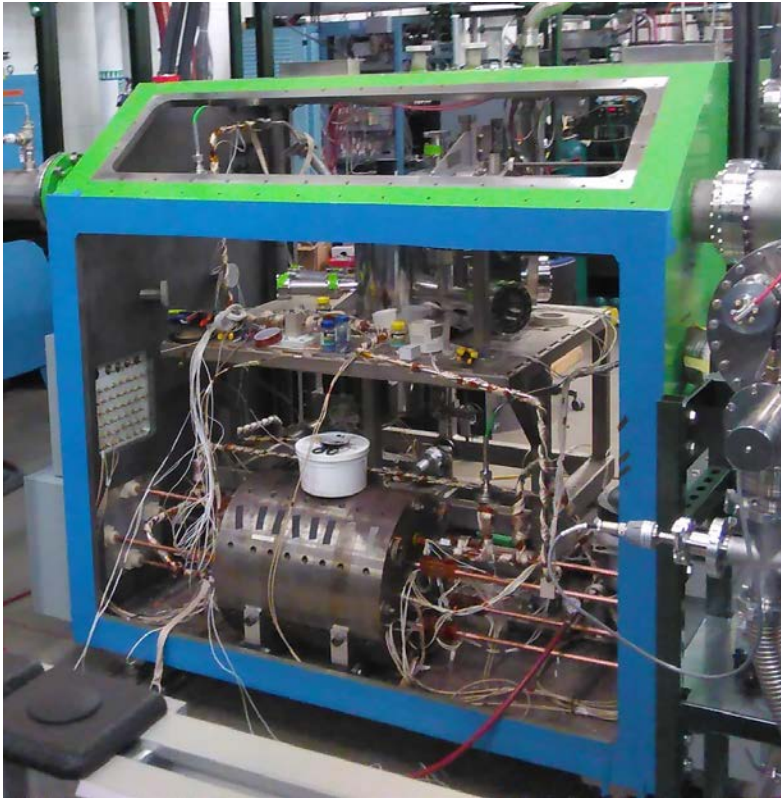

Lithium Loop Configuration

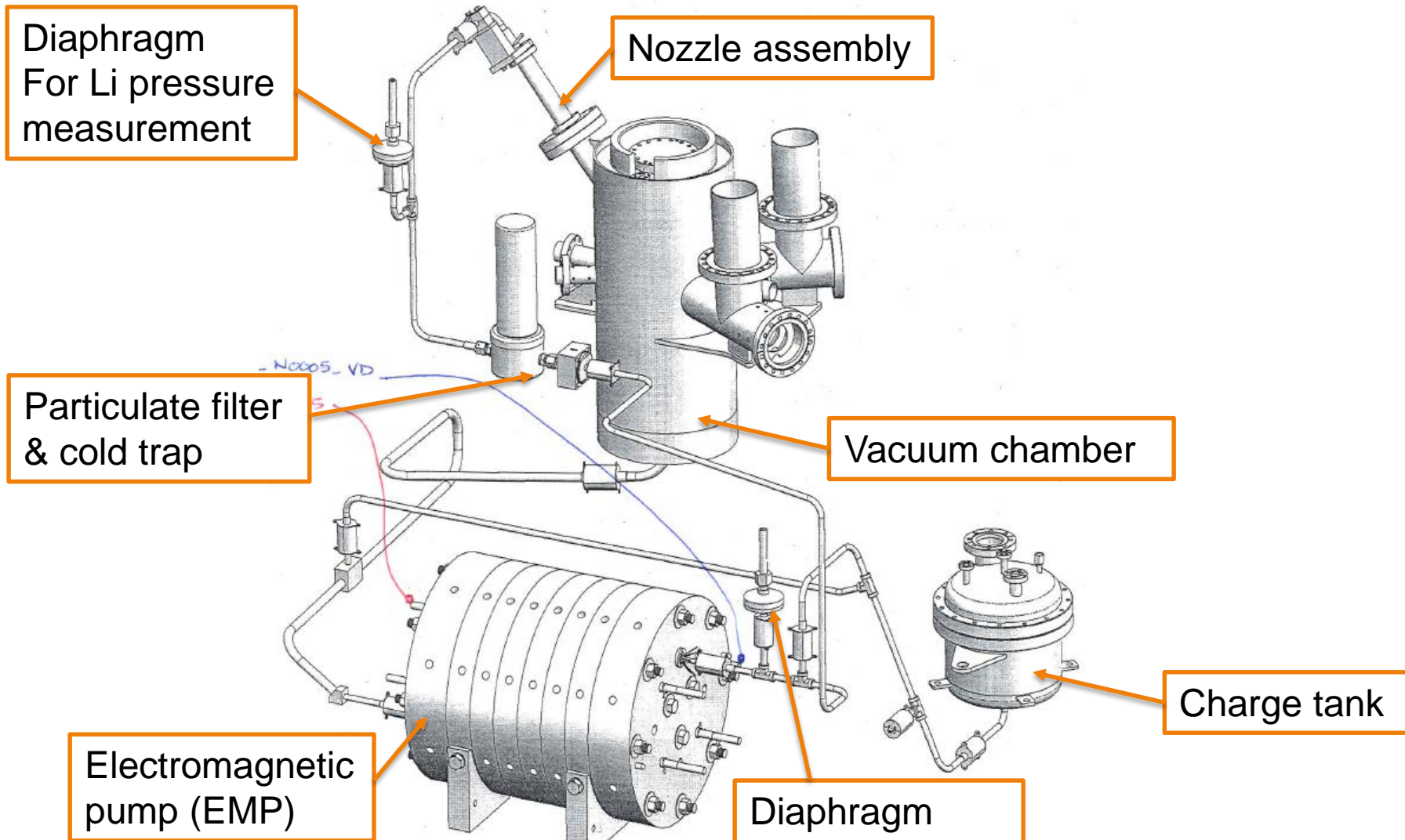

Stripper Film Produced by High Velocity Jet

- The thin lithium film needs to move very fast (~ 50 m/s) to remove the heat away from the impact point.
- This is achieved by producing a high pressure (~ 1.4 MPa) lithium flow in a 0.5 mm diameter nozzle.
- The jet impinges on a flat deflector and produces the thin film.

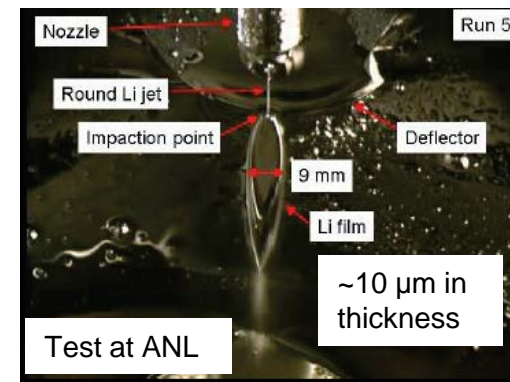
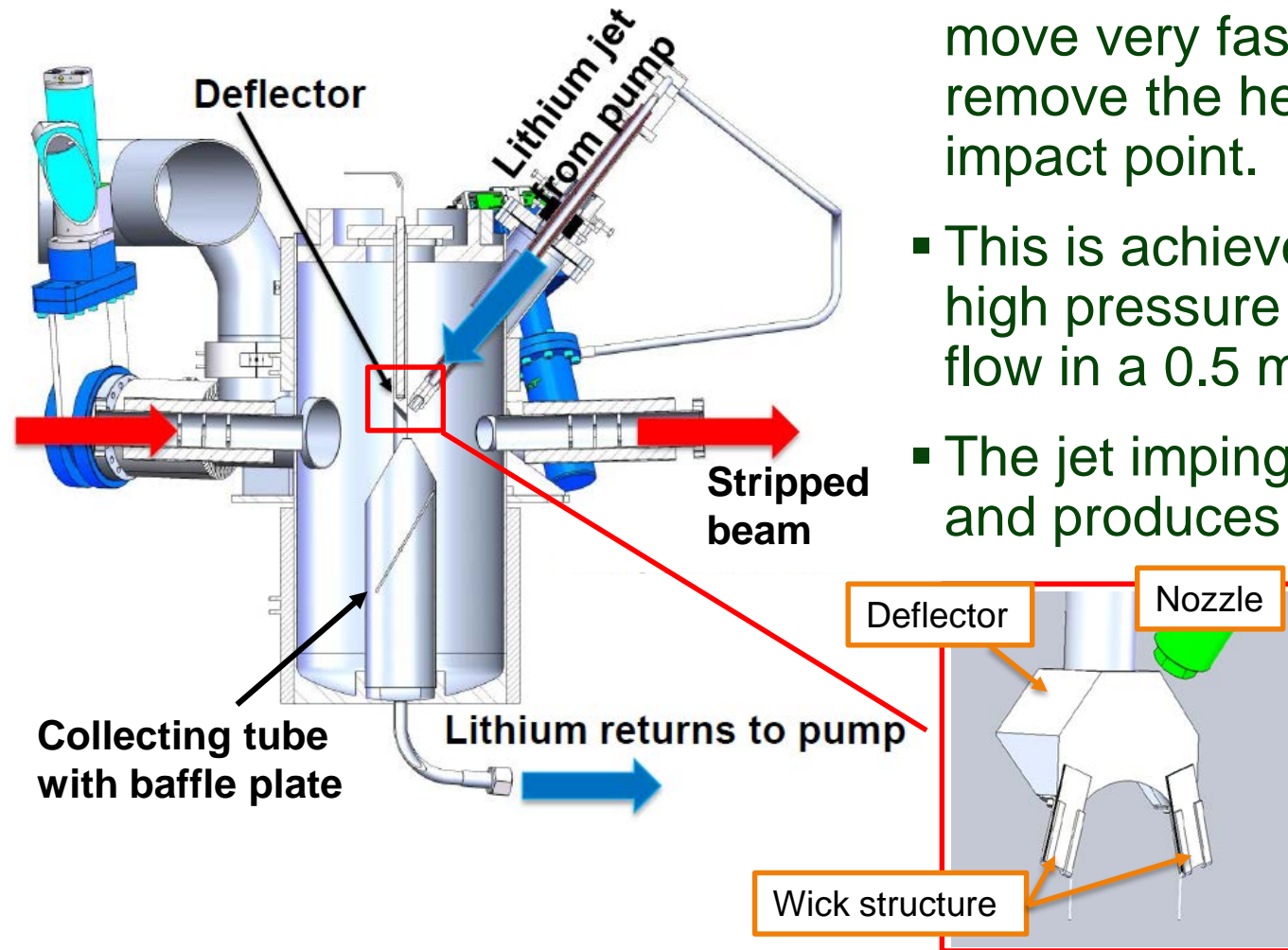

Y. Momozaki et al., 2009 JINST 4 P04005

Technical Challenge:

How do we Pump the Lithium at the Required Pressure?

- The experiments performed at ANL used a single pass lithium system, allowing runs of ~20 minutes before recycling
- In other applications the liquid metals are moved by mechanical pumps (large flow rate) or AC-type electromagnetic pumps (EMP). These pumps do not provide the pressure stability needed by our stripper. The pressure stability determines the film stability.
- Requirements
 - Relatively high pressure (~1.4 MPa)
 - Very low flow (5 – 10 cc/sec)
 - Minimum pressure fluctuation (pressure stability)
 - Low heat generation in the pump (Commonly used pumps require a larger flow to dissipate heat produced in the pump)

DC Electromagnetic Pump Chosen for FRIB Lithium Stripper

- We have developed a DC permanent magnet pump
 - Lithium circulates in a helical tube coil with current flowing parallel to the coil axis and a permanent magnetic field perpendicular to the axis.
 - Lorentz force created by interaction of a permanent magnetic field and a DC current pushes lithium along the long (24 m) helical tube and creates a high pressure at the outlet.
 - This is a high temperature version of a pump developed for Ga/In by R. Smither at ANL

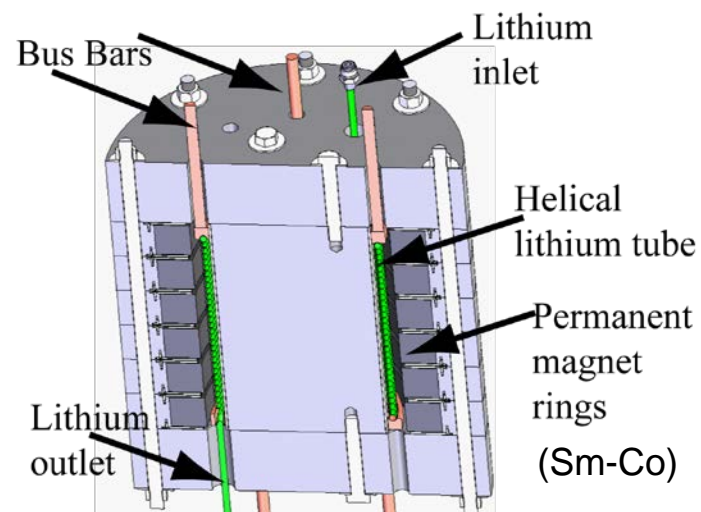
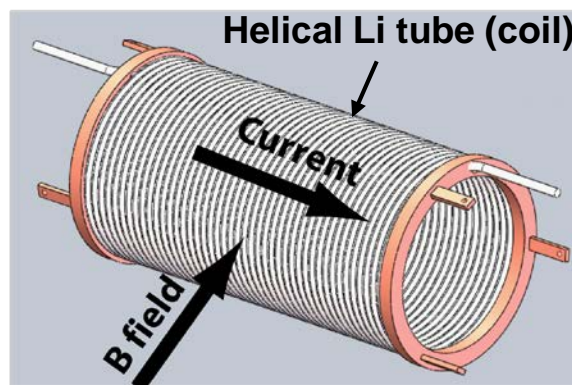
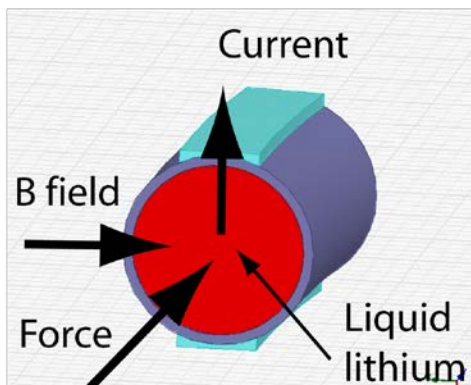

Pump Working Principle

■ Brief description of pump working principle

- $P_{EMP} = JBL$:

- » J : current density in Li
- » B : magnetic flux density in Li
- » L : coil length along flow path

- Here, $J = J_S - J_{CEMF}$

- » J_S : Current density obtained by supply current I_S
 - The magnitude of J_S is proportional to I_S
- » J_{CEMF} : Current density due to counter electromotive force (CEMF) induced by flow
 - The direction of J_{CEMF} is the same as the vector product $u \times B$
 - The magnitude of J_{CEMF} is proportional to Li speed u

- Thus, P_{EMP} increases linearly with I_S and decreases linearly with lithium flow velocity u

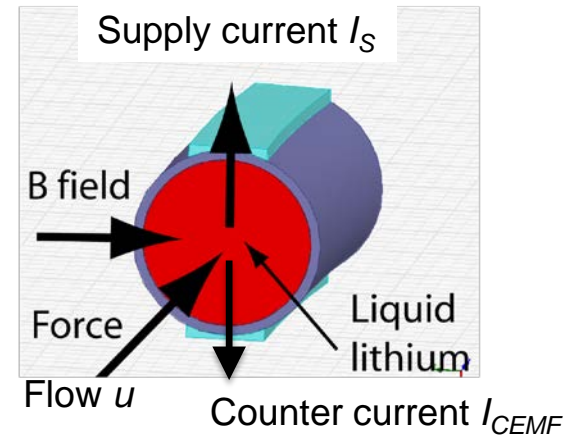

Test Stand for Pump Performance Evaluation

■ Lithium pump test at contractor's site

- The lithium is under a slight argon pressure (~3 psi) in the feed tank
- The pump pushes the lithium toward a tank on a scale used to determine the mass transferred in a given time
- The flow is controlled by adjusting a needle valve
- For a given pump current and needle valve setting we measured the pressure and time needed to transfer 1 lb of lithium to the weigh tank

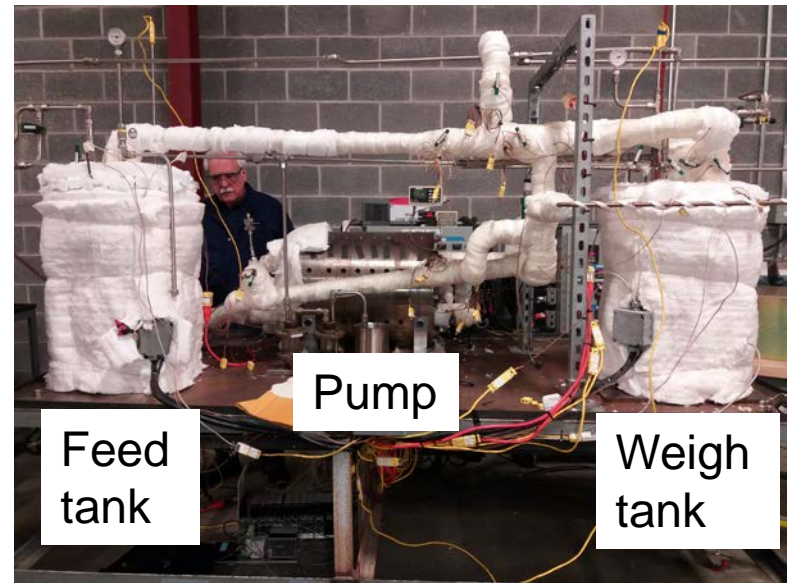
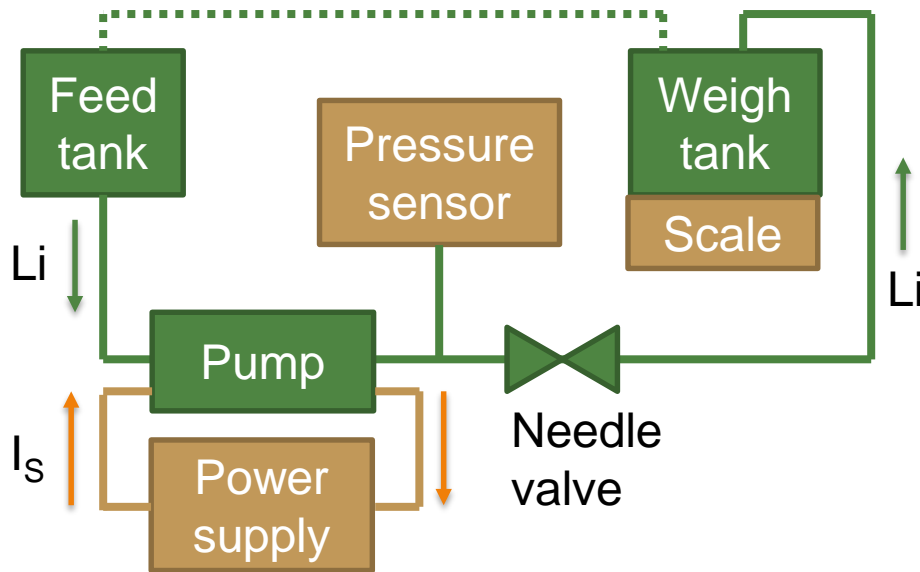

Performance Result without Flow

- Pump performance with zero flow
 - $P_{EMP} \propto I_S (u = 0)$

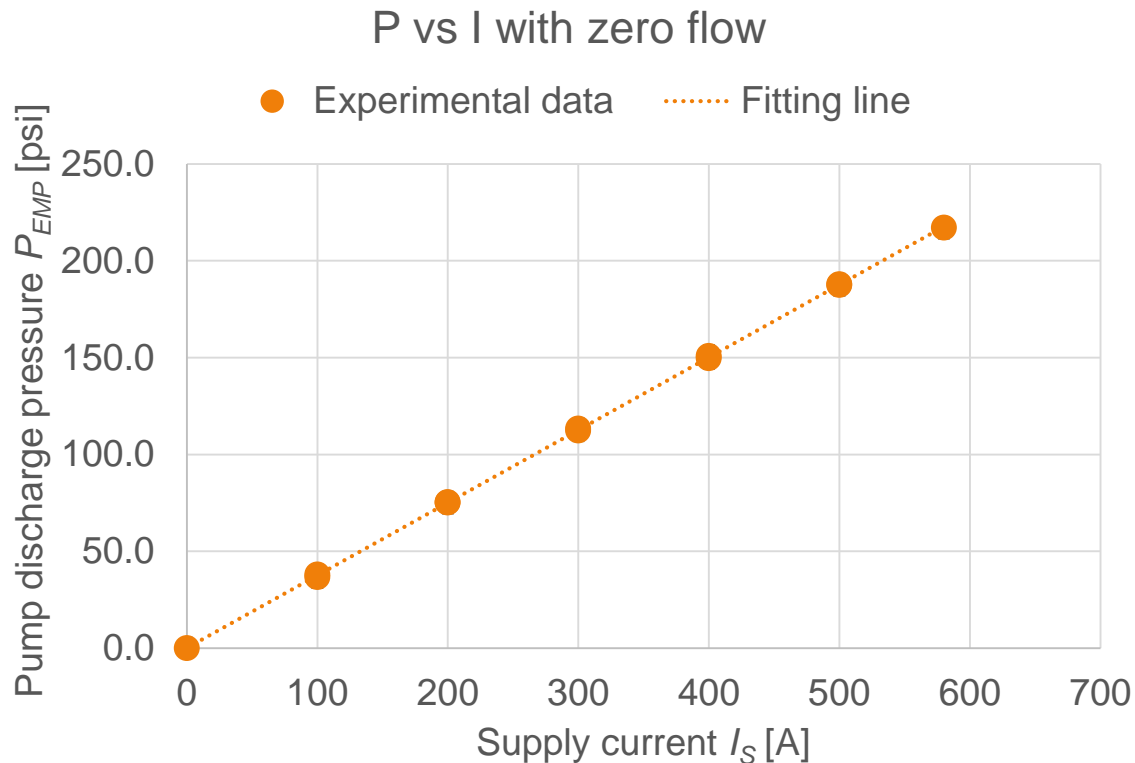

Performance Result with Flow

- Pump performance with flow
 - P_{EMP} depends on I_S and flow rate F
- Pump performance curve obtained experimentally (dashed lines)
 - Determination coefficient: 0.97
 - Standard error: 3.3 psi
- It is concluded that **our pump has adequate performance to produce desired pressure (~200 psi) and flow rate (5-10 cc/s)**
 - The present power supply is capable of up to 1600 A and cables in tunnel conduits ready for 2000 A

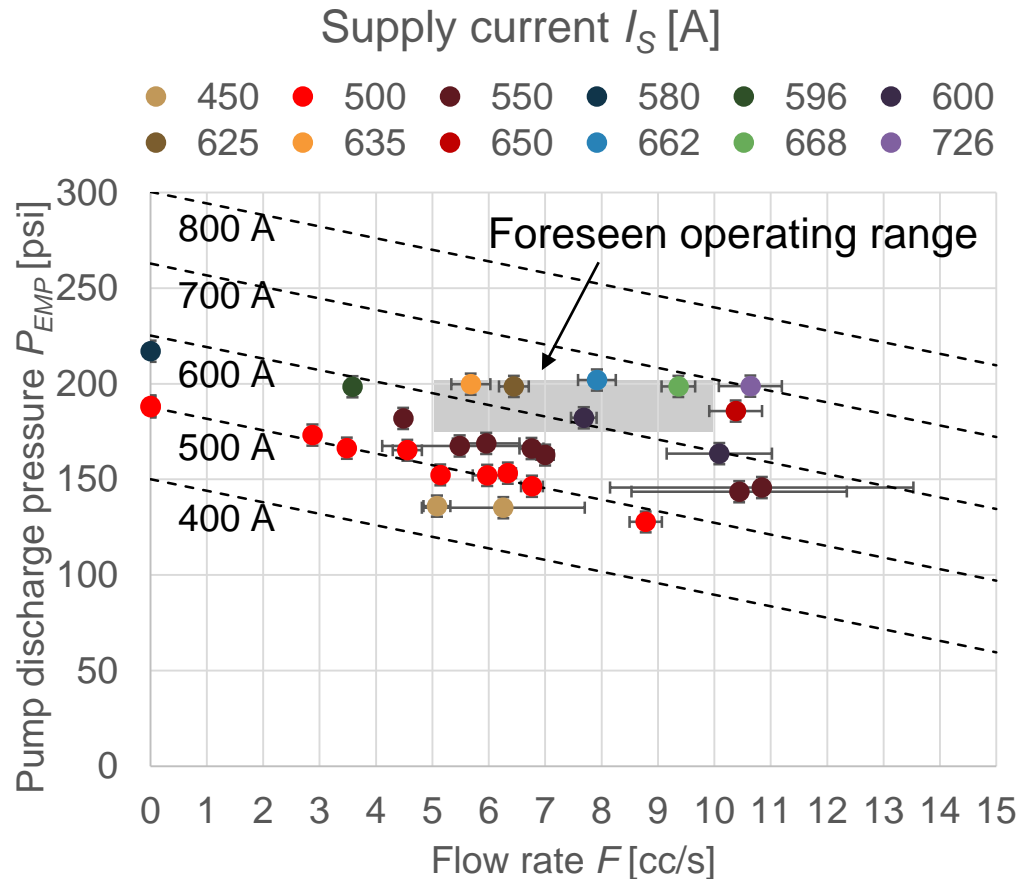

Very Small Departure from Linear Performance Curve

- Fitting error [%] = (experimental data - fitting data) / fitting data x 100
- It is obvious that the fitting line excellently represents the experimental data
- The pump performance test was a big success.

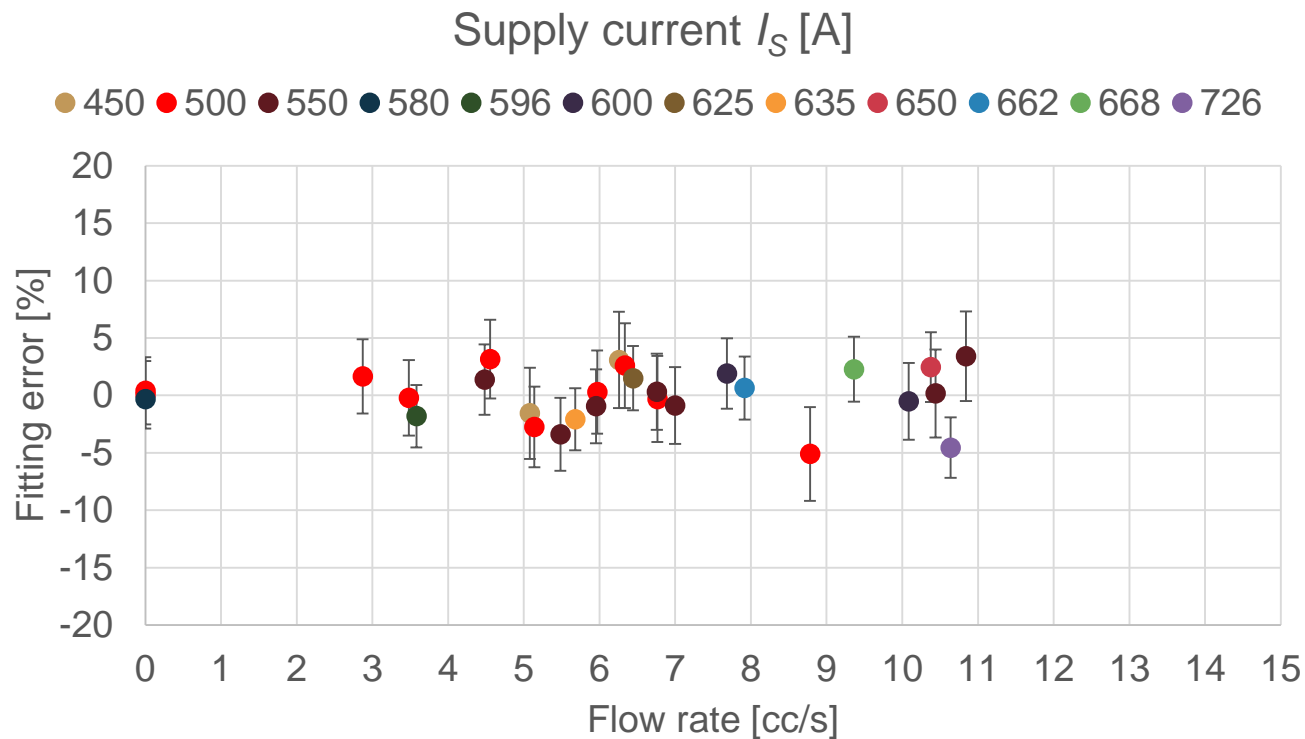

Mitigation of Hazards Associated with Liquid Lithium

■ Lithium Hazards

- Liquid lithium is considered pyrophoric.
 - » Solid lithium is NOT pyrophoric.
- Reaction with water, generating heat and hydrogen, potential of lithium fire
- Reaction with air, generating heat, potential of lithium fire

■ To mitigate these hazards, we need to keep liquid lithium from contacting air/water during operation.

■ Mitigation of lithium hazards

- Use only materials that are compatible with liquid lithium (e.g. NO copper nor aluminum)
- Secondary containment vessel that encloses the entire primary lithium loop and is filled with inert argon at a positive pressure (~7 kPa). Even if lithium leaks out of the primary loop, it will not catch a fire.
- Oxygen monitor that ensures the inert environment in the SV.
- If a loss of vacuum is detected on the vacuum chamber, we shut off the valves that connect the stripper to the rest of the beamline, and the chamber starts to be filled with argon along with system shutdown (EMP off, Cooldown).

Various Controls Assure Safe Operation

| Controls with ESH impact | Credited / Non-credited | Control type |
|--|---------------------------------|----------------|
| Secondary containment vessel | Credited | Passive |
| Argon system | Credited | Active |
| Vacuum monitoring | Non-credited (defense in depth) | Active |
| Li leak detection | Non-credited (defense in depth) | Active |
| Over-pressurization relief | Non-credited (defense in depth) | Passive |
| O ₂ detection | Non-credited (defense in depth) | Active |
| Exhaust dry filter system | Non-credited (defense in depth) | Passive |
| Li handling procedures and training | Credited | Admin |

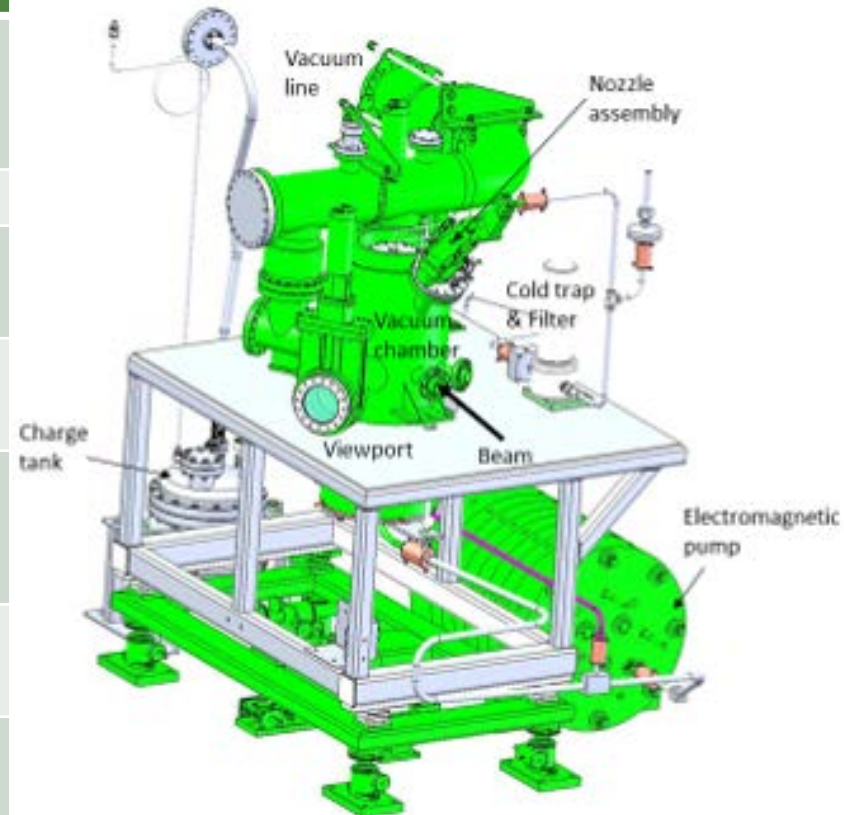

Response to Abnormal Events within Operational Envelope

- Fire may occur only when two or more failures occur simultaneously
 - Lithium leak from primary to secondary vessel AND air leak from outside into secondary vessel
 - Air leak from outside to primary chamber AND malfunction of Ar system
- Device de-energized when any one of the following abnormal conditions occurs
 - Li leak detector #1 and #2 abnormal readings; oxygen sensor abnormal readings; vacuum gauge reading abnormal; pressure sensor abnormal readings
- Device de-energized when any one of the following systems fails
 - Any Li leak detector failure; oxygen sensor failure; pressure sensor failure; Ar fill or Ar flood system failure

Most Recent Progress

- ✓ Load lithium into the charge tank: Done
 - The system was loaded with necessary amount of lithium (total 2.4 kg)
- ✓ Charge lithium into the piping: Done
- ✓ Circulate lithium with the Electromagnetic Pump (EMP): Done
 - After successful lithium charging, lithium circulated using the EMP for the first time in the FRIB lithium stripper loop.
 - After the first circulation, continuous lithium circulation for 48 hours was done.

First Lithium Circulation Completed: Lithium Flow Video

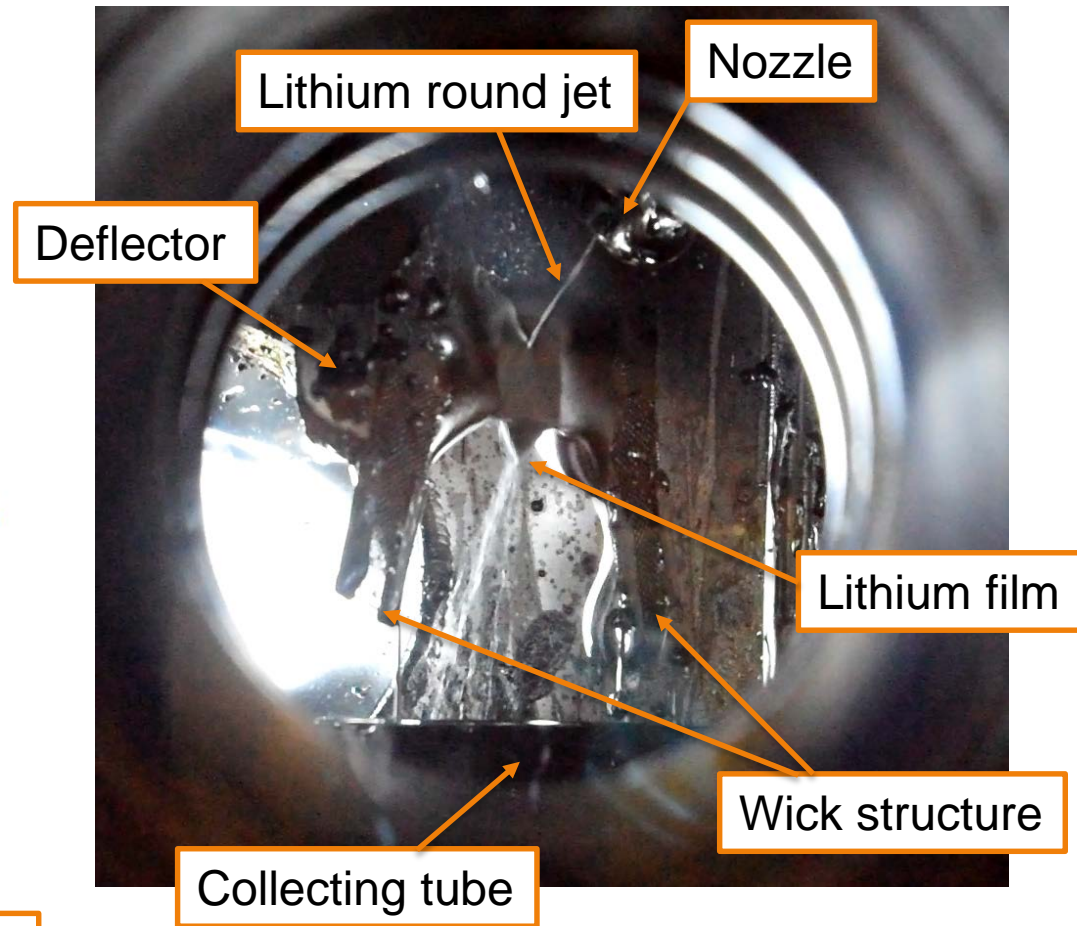
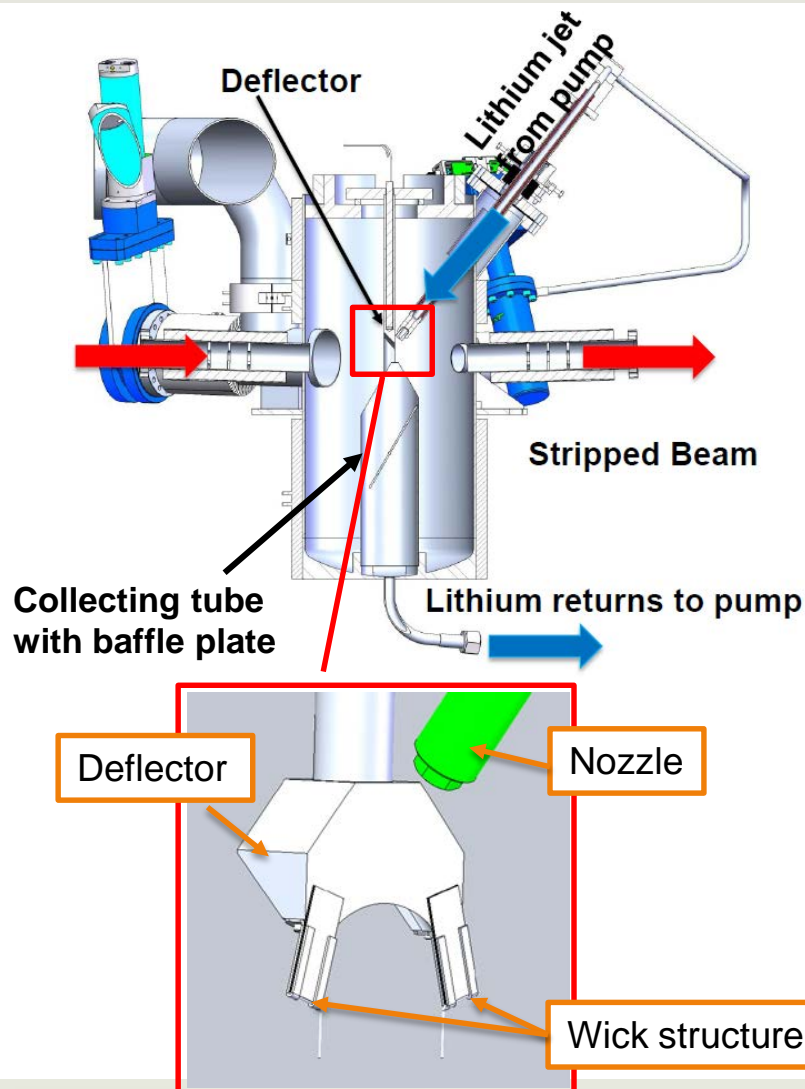

Continuous Lithium Circulation Completed: Stable Operation Achieved over 50 Hours

- As the next step, we tried the continuous operation for 48 hours.
- Result: No interruption, no alarm, no safety interlock activated.
- The system had been stable for the entire period.

Result: No interruption, no alarm, no safety interlock activated.
The system had been stable for the entire period.

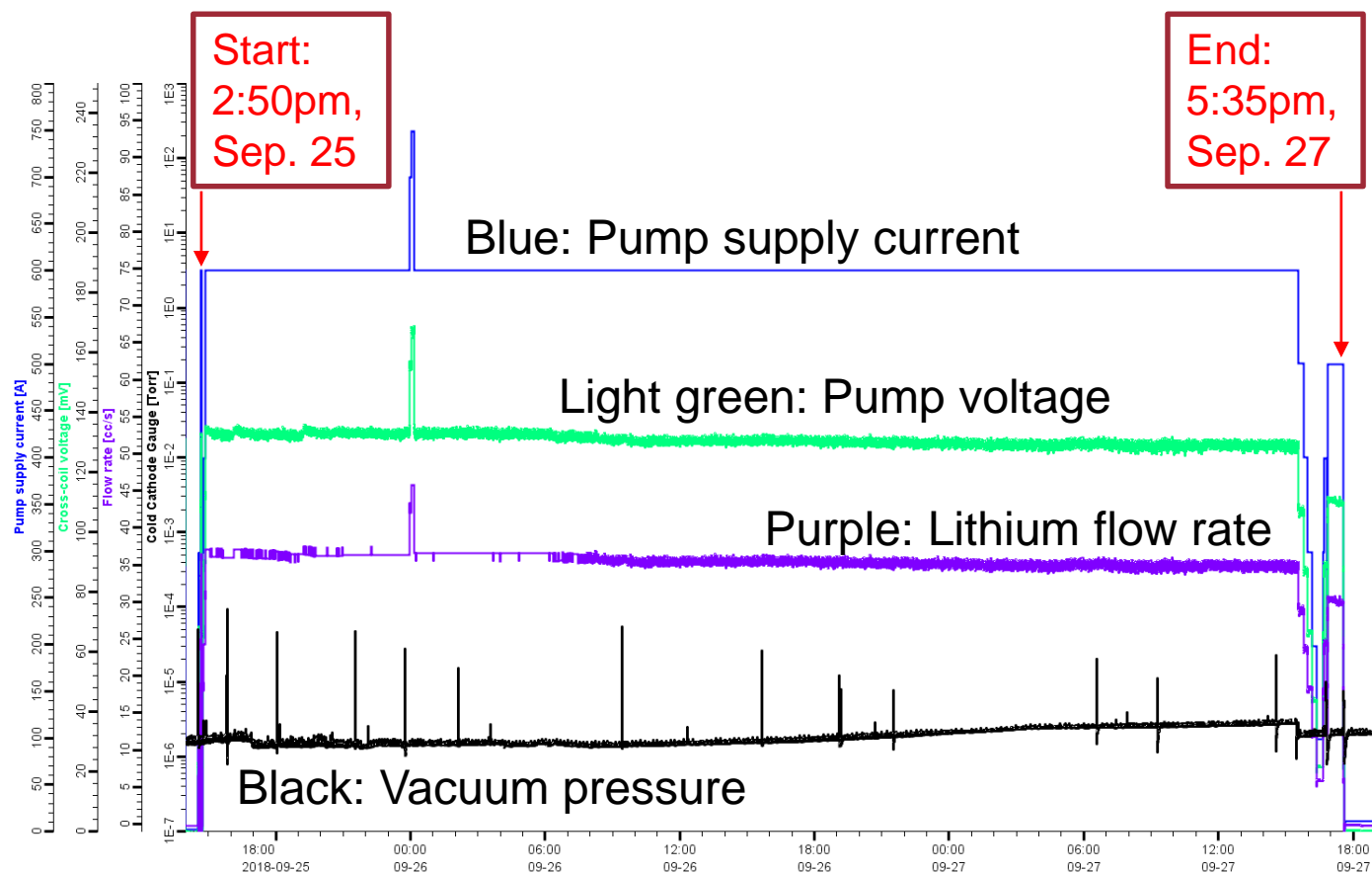

Lessons Learned from Recent Operations

- EM pump worked as designed
- All the instrumentations worked well.
- Wick structures efficiently removed lithium puddle on the deflector.
- The results of the continuous operation demonstrated that the system can be operated safely, reliably and robustly.
- The system will be operated unmanned because of this successful completion of the continuous operation. All safety interlocks and security measures have been implemented for the unmanned operations.

How to Measure Film Thickness: Use of Electron gun

- In collaboration with ANL to design and build FRIB, R&Ds were performed to verify the stability and thickness ($\sim 12 \mu\text{m}$, $\pm 5\%$ for 1 mm diameter spot) of the lithium film in 2010 [1].
- Thickness measurement:

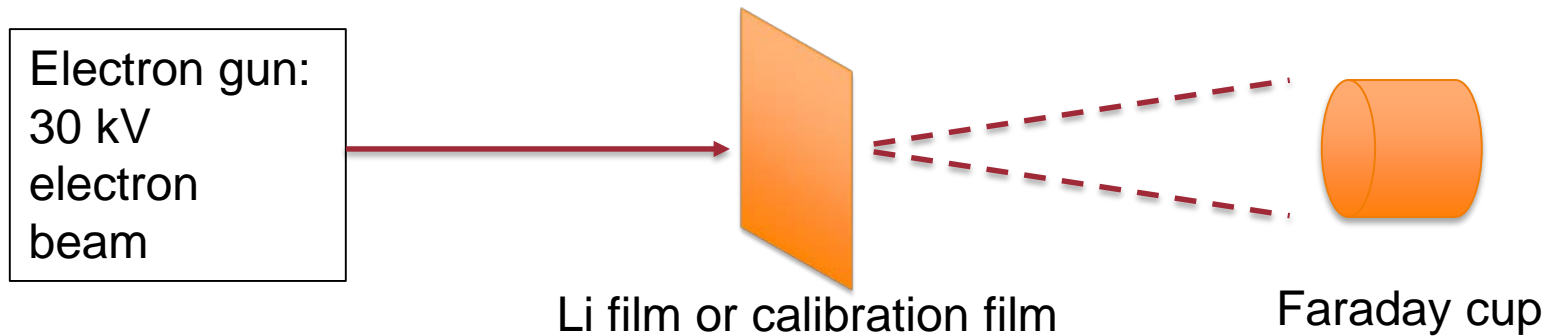

The fraction of the electron current captured on a fixed size Faraday cup is determined by the scattering, function of the film thickness

- The same system is being built at FRIB.

[1] C. B. Reed at al., FRIB Lithium Stripper Thickness and Stability Measurements, ANL/NE-11/01

Electron Gun Offline Test Stand for Calibration of E-Beam Current Reading

■ Purpose:

- Calibration of e-beam current readings using carbon foils with known thicknesses

■ Configuration

- The configuration of the offline test stand is identical to the one to be installed to the lithium stripper module, except for the vacuum chamber and stand frame

■ Schedule

- Test stand assembled: November 2018
- Offline test: December 2018
- Commissioning after installed to stripper module: March 2019

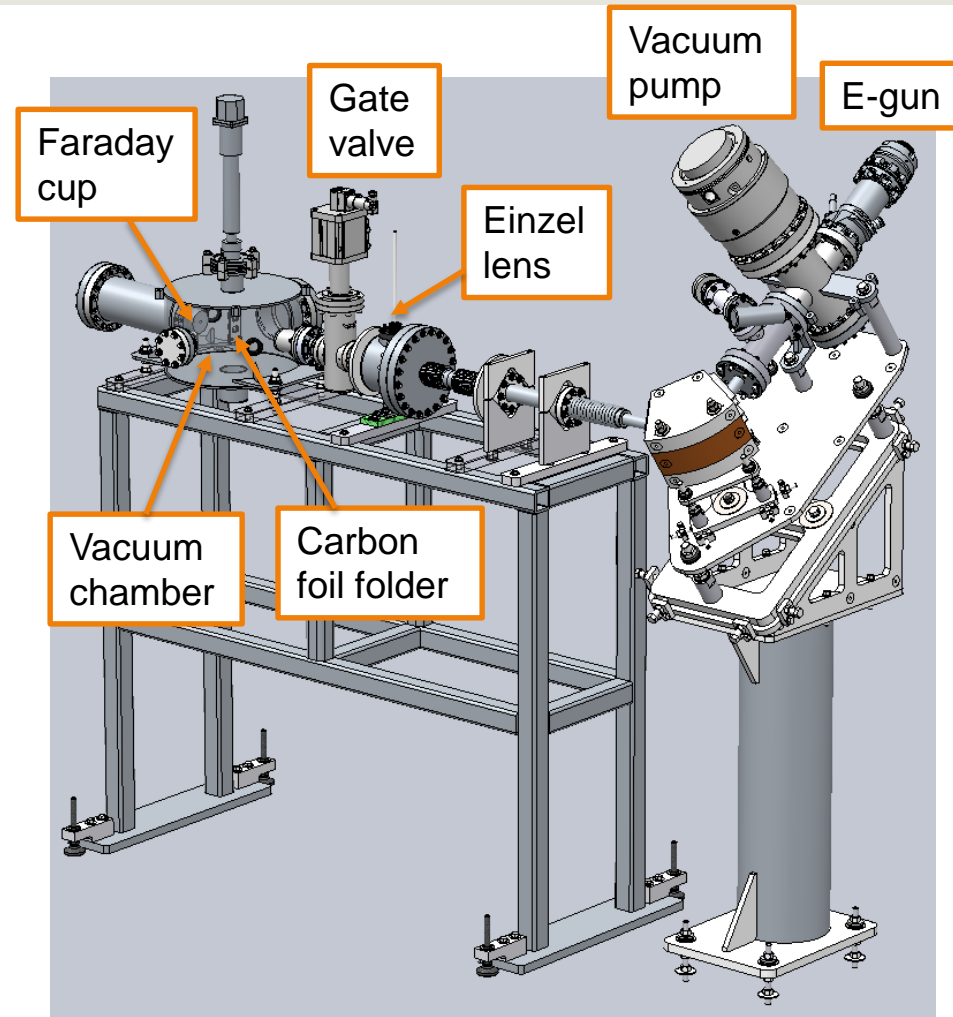

Path Forward

■ Upcoming major milestones

- 7/2019: Measurement of lithium film with electron gun system
- 5/2020: Ready for tunnel operation
- 7/2020: Commissioning of lithium charge stripper with beam
- 12/2021: Ready for production operations

■ Remaining tasks

- Continuous operation for two weeks or longer with electromagnetic pump
- Diagnostics for film thickness measurement
- Evaluation of erosion/corrosion of nozzle / deflector for maintenance consideration
- Calculation of residual radiation with the latest lithium stripper design (initial calculation already done considering the worst case scenario: ^{18}O beam 637 MeV/u, 30 year irradiation (not in baseline). Result: Max. 73 mrem/hour outside the secondary vessel).

Summary

- The FRIB liquid lithium charge stripper has made steady progress toward beam-on commissioning operation in 2020, and production operation beyond 2022.
 - The lithium stripper module is now operational.
 - Liquid lithium circulated with the EMP, which we have developed based on R. Smither's original concept, for the first time in the FRIB lithium stripper module, followed by the continuous operation for over 50 hours without any interruption.
 - Our safety controls for mitigation of lithium related hazards have worked well so far. Main feature is the secondary containment vessel filled with inert argon.
 - We continue operation at the offline test site to gain operational experience and establish solid maintenance plan for tunnel operation.

