



# SuperKEKB

R&D for SuperKEKB and the next generation high  
luminosity colliders

M. Tobiyama(KEK), J. Seeman(SLAC)

A 3D Point Scan Magnetic Field Measurement System for  
Accelerator and Detector Magnets

N. Ohuchi(KEK), T. Strauss(FNAL) , P. Winter(ANL)

Construction of superconducting coils for the interaction region  
of SuperKEKB and magnetic field measurements for the nano-  
beam accelerator

N. Ohuchi(KEK), B. Parker(BNL)

Makoto Tobiyama(KEK Accelerator Laboratory)

SuperKEKB, the first new collider in particle physics since the LHC in 2008 (electron-positron ( $e^+e^-$ ) rather than proton-proton (pp))

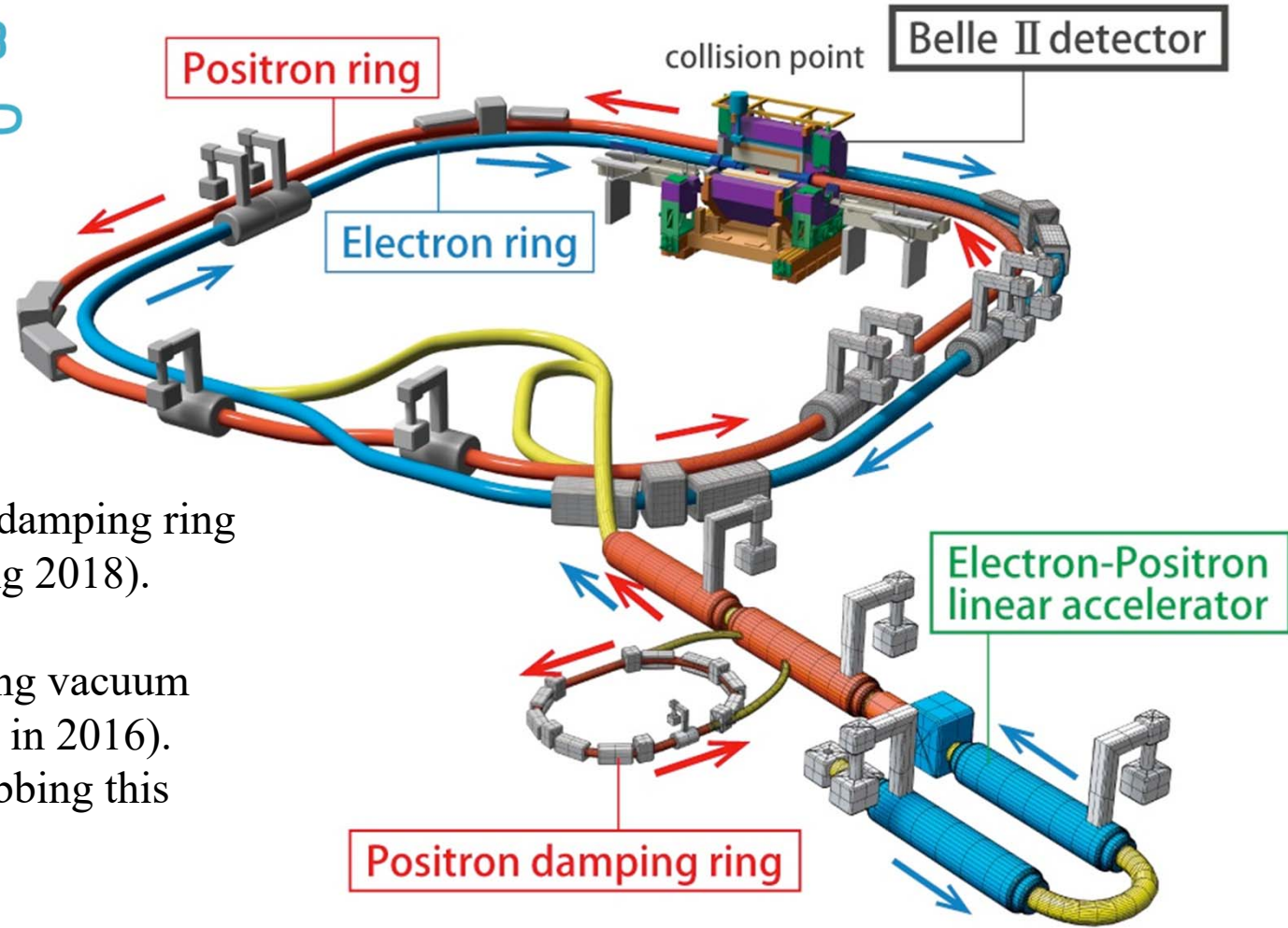

Some items to note:

1) Brand-new positron damping ring (commissioned spring 2018).

2) New 3 km positron ring vacuum chamber (commissioned in 2016). Optics and vacuum scrubbing this spring.

3) New complex superconducting final focus (commissioned this spring 2018).

# SuperKEKB/Belle II Luminosity Profile

Belle/KEKB recorded  $\sim 1000 \text{ fb}^{-1}$ . Now have to change units on the y-axis to  $\text{ab}^{-1}$

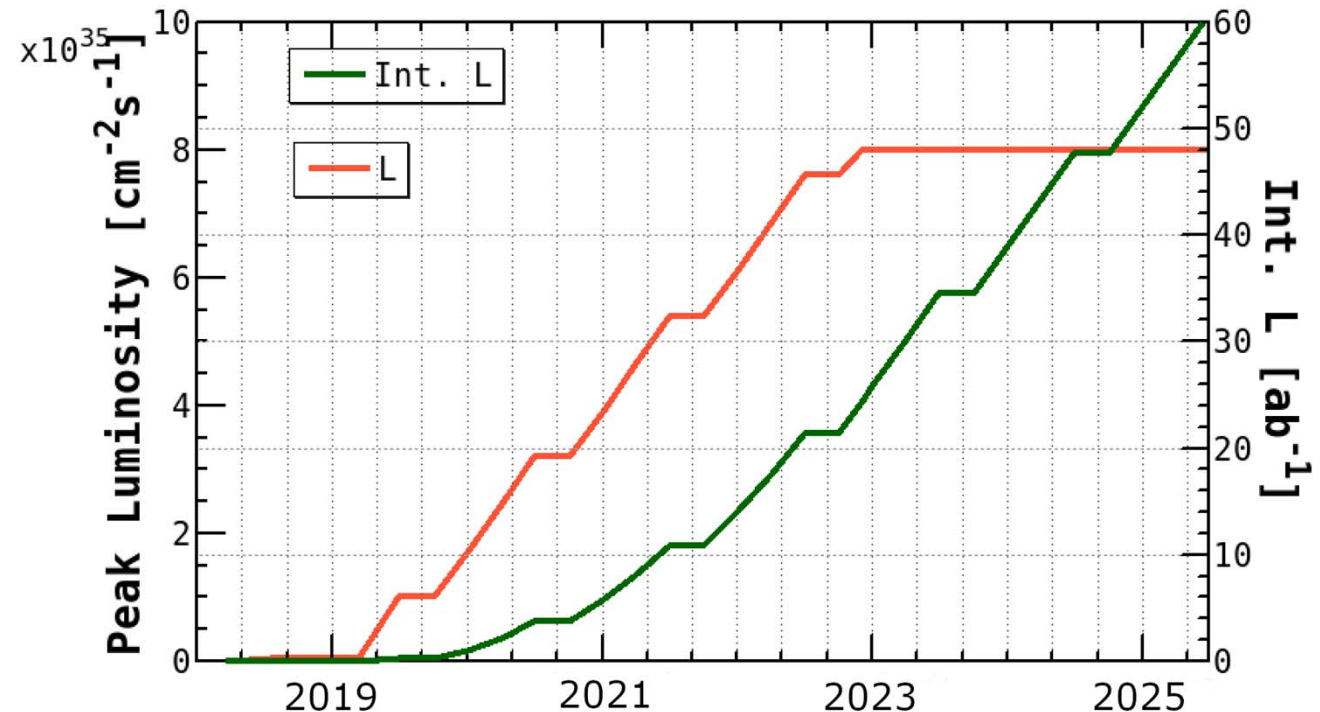

Beam currents *only* a factor of two higher than KEKB ( $\sim \text{PEP-II}$ )

“nano-beams” are the key; vertical beam size is **50nm** at the IP

N.B. To realize this steep turn-on, requires close cooperation and planning between Belle II and SuperKEKB

[and some *international collaboration* on the accelerator, including the US and Europe e.g. **BNL** built the corrector coils for the SuperKEKB superconducting final focus].

# Introduction

- **Development and fabrication of accelerator components important to the construction and operation of the SuperKEKB accelerators.**
  - Next generation Bunch feedback
  - IP collision feedback
  - X-ray beam size monitor
  - Large Angle Beamstrahlung Monitor
  - Beam collimators
  - E-cloud study and cure
  - LLRF modeling
  - Accelerator Physics
  - High quality injector
  - Superconducting final quadrupole (QCS)
- **Achieve SuperKEKB design luminosity faster!**
  - Education of young scientists/engineers for future accelerators
- **Supported by US–Japan Collaboration since JFY2003**

## Example of Achievements (long term)

- **General purpose bunch-by-bunch feedback processors (iGp) and tuning tools for BxB feedback.**
  - Understanding of electron-cloud instabilities, fast ion instabilities
  - Widely used on the light sources
  - Intra-bunch feedback for proton accelerators (J-PARC, SPS)
- **Surface treatments of vacuum chambers (TiN, DLC coating, Grooved surface, etc) to suppress electron-cloud instabilities.**
- **Improvement of beam-beam related simulations.**
- **Superconducting final quadruples (QCSs) for SuperKEKB**

# History of Phase 2 operation

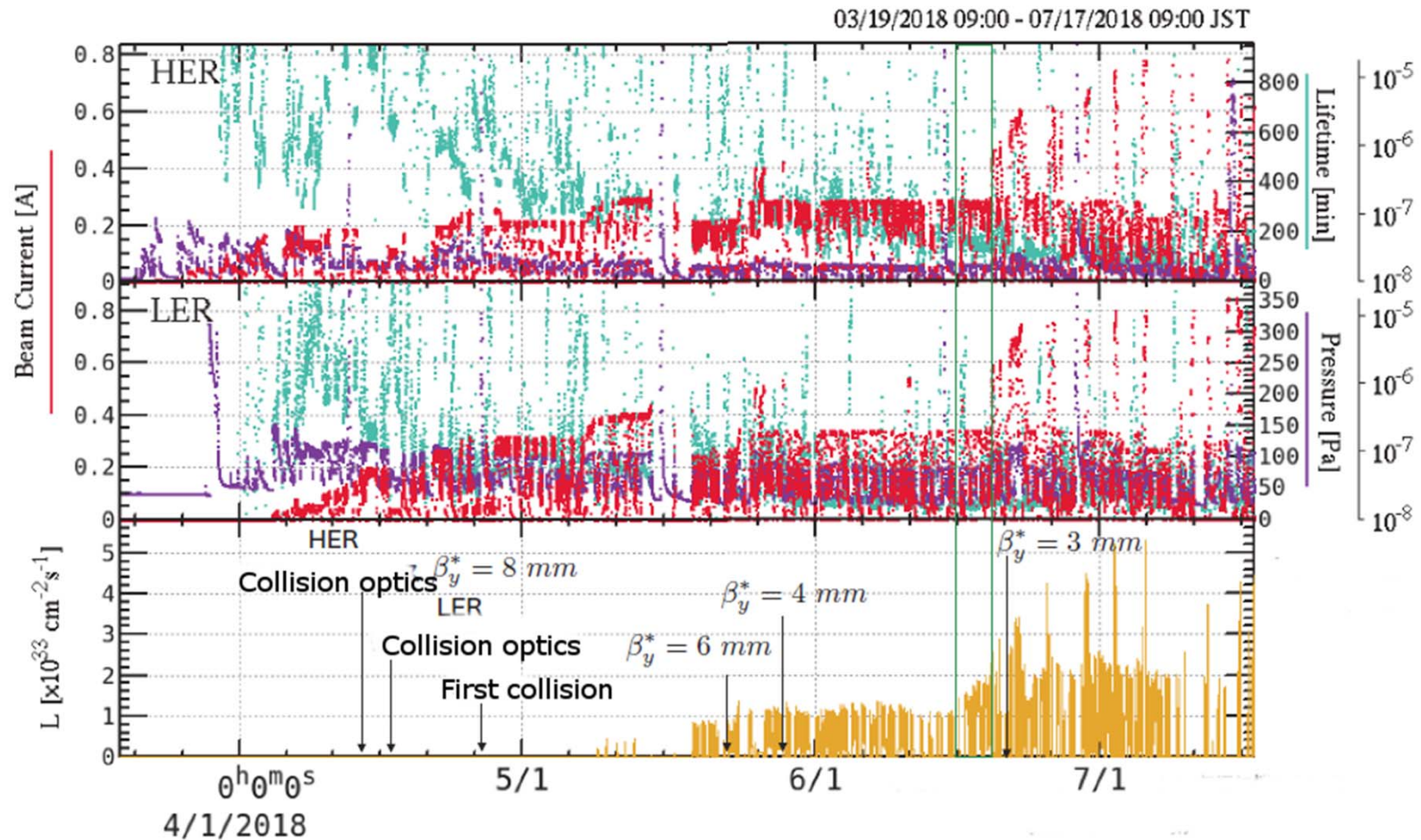

Peak luminosity  $> 5 \times 10^{33} / \text{cm}^2 / \text{s}$

# First hadronic event on 26/Apr/2018

2018年 4月26日 午前0時38分

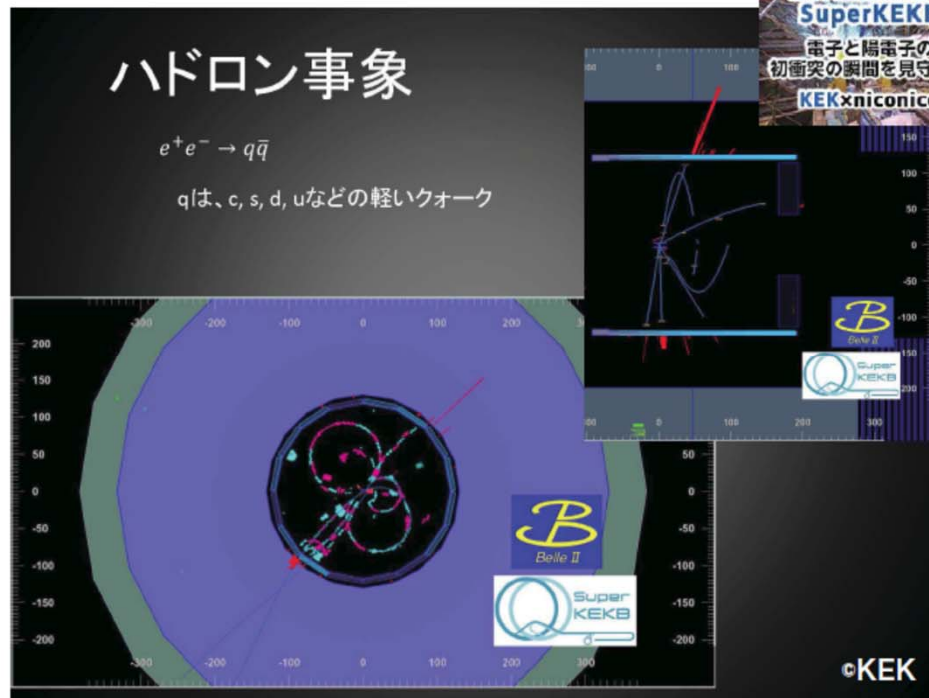

加速器コントロール・ルーム



Belle II測定器コントロール・ルーム



# Phase 3 operation

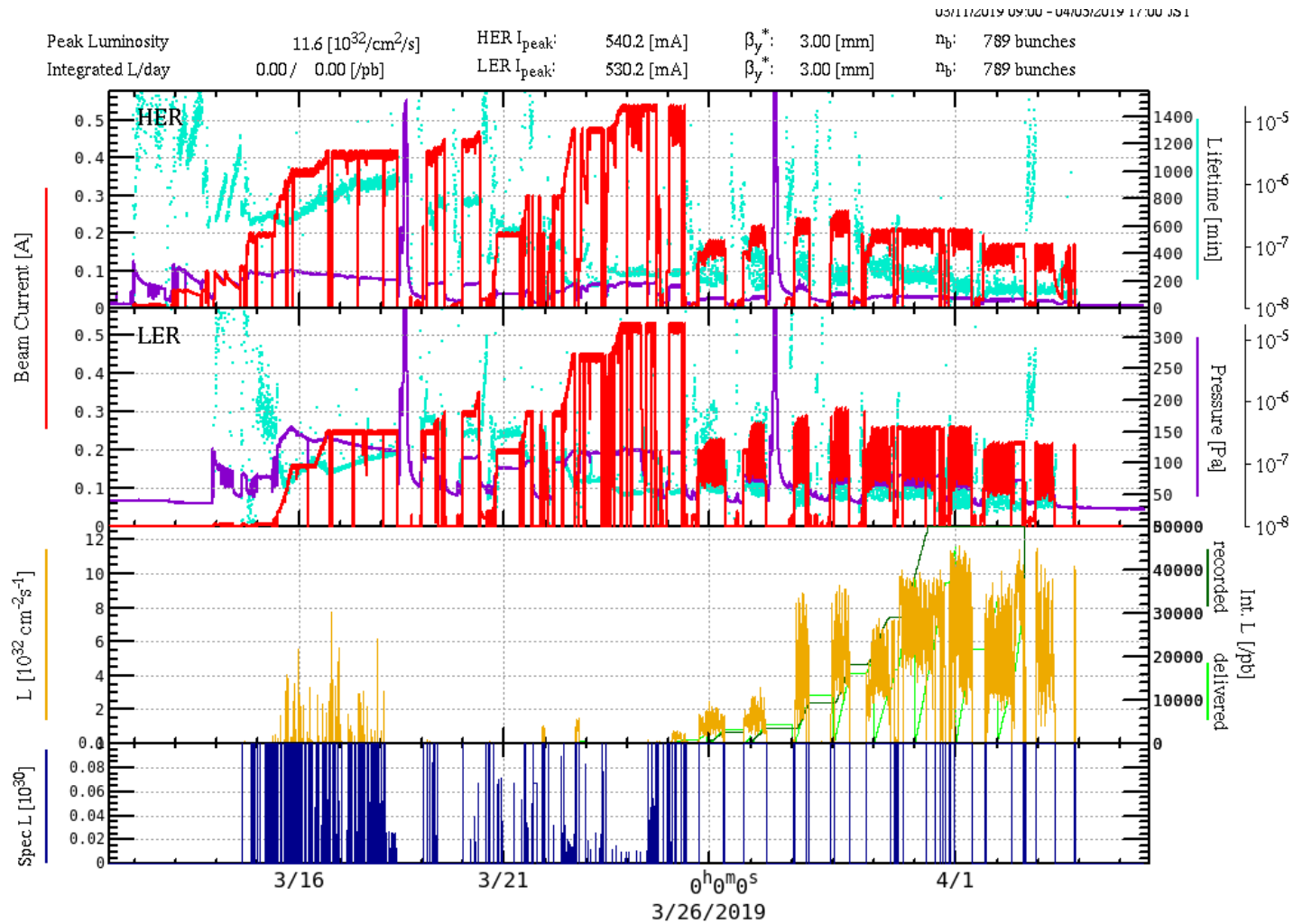





## Luminosity and Specific Luminosity

March 27 - April 3, 2019

$$L_{sp} = 1.77 \times 10^{25} \frac{1}{\Sigma_y^*} [cm^{-2}s^{-1}/mA^2]$$

$$\Sigma_y^* = \sqrt{\sigma_{y,e+}^{*2} + \sigma_{y,e-}^{*2}}$$

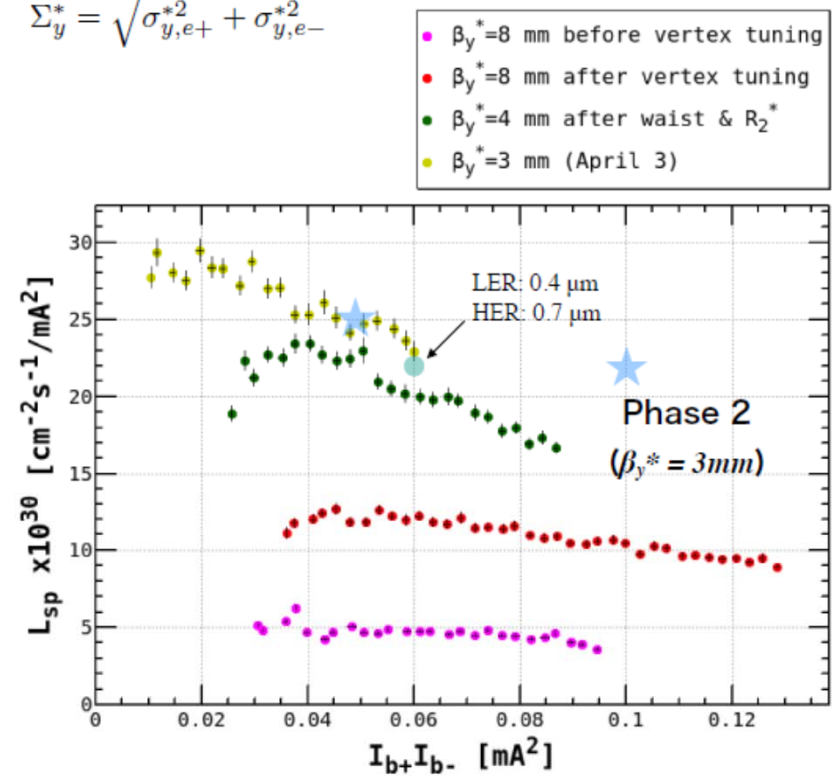
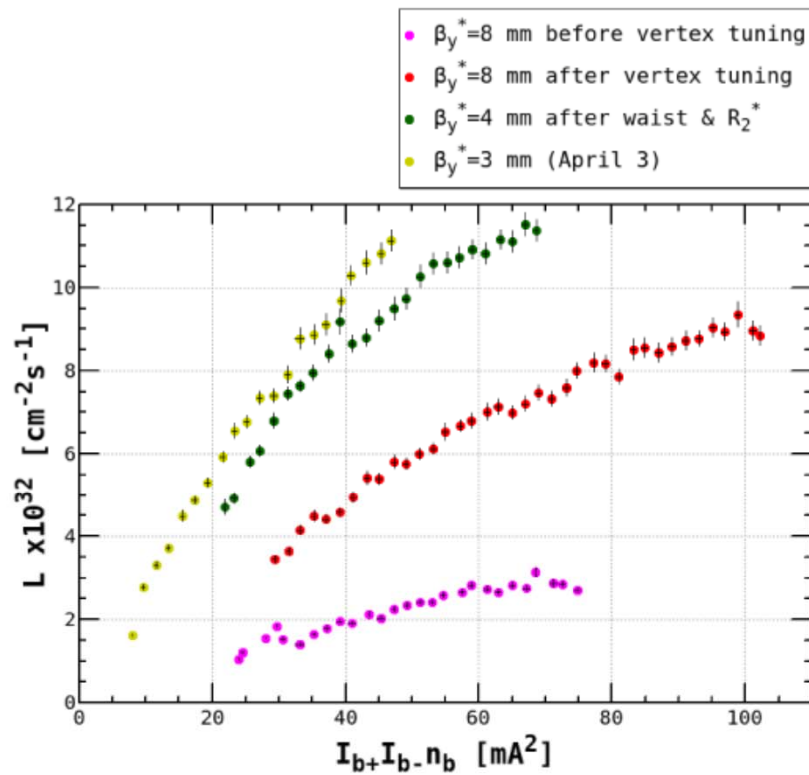

## Phase 3 status

- Started positron damping ring on 18/Feb, HER/LER on 11/Mar.
- Successfully restored  $\beta y^* = 3$  mm colliding optics after 3 weeks of operation.
- Concentrating the beam background studies to establish luminosity run with continuous injection state.

# Superconducting Corrector Development

- Direct winding SC Corrector by **BNL** (2013-2015)
  - The SC correctors were designed and directly wound on the support bobbin (helium inner vessel) by BNL under the US-Japan research collaboration
    - Direct winding method: BNL special technique using SC wire bonding to the bobbin with ultrasonic heating
    - Multi-layer coil [maximum layer=4 by limiting with the gap distance between the main quadrupole magnet and the helium inner vessel]
    - Some correctors were assembled on the outer surface of the main quadrupole magnets.

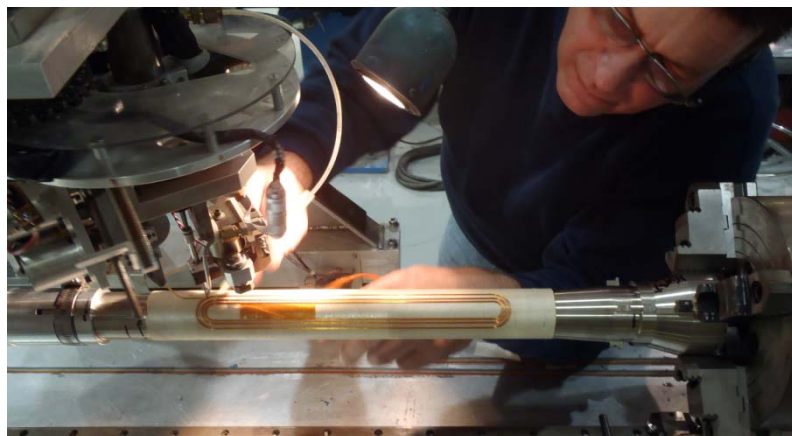

$a_1$  corrector winding for QC1LP @BNL

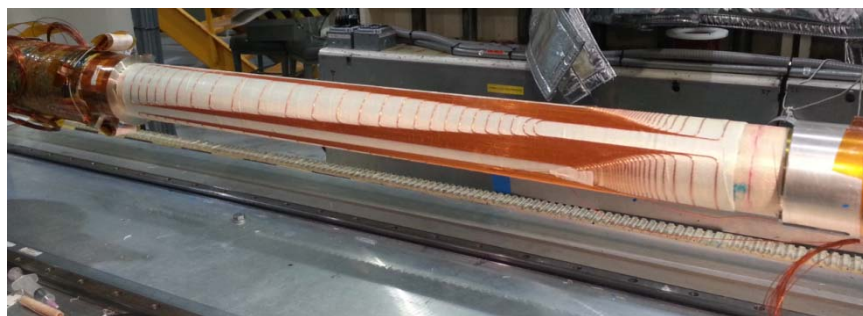

Assembly of QC2LE and correctors

Special shape SC corrector magnet for cancelling the leak magnetic field on the HER beam line from QC1LP quadrupole magnet(LER)

# Single Stretched Wire (SSW) System

- Development of the SSW system in SuperKEKB IR by **FNAL** (2013-2017)
  - The system design started from 2013 for the direct measurements of the field center and the field angle of 8 SC quadrupole magnets. The system was completed in 2015, and it was transferred from FNAL to KEK in 2016.
    - The SSW system directly measures the quadrupole field centers and angles with respect to the beam lines with the precision of  $\pm 0.1$  mm for the 8 SC quadrupole magnet. The wire is stretched along the ideal beam line which goes through IP.
    - The field measurements of the SC quadrupole magnets in the Experimental Hall and on the beam line were performed with FNAL and KEK collaboratively.

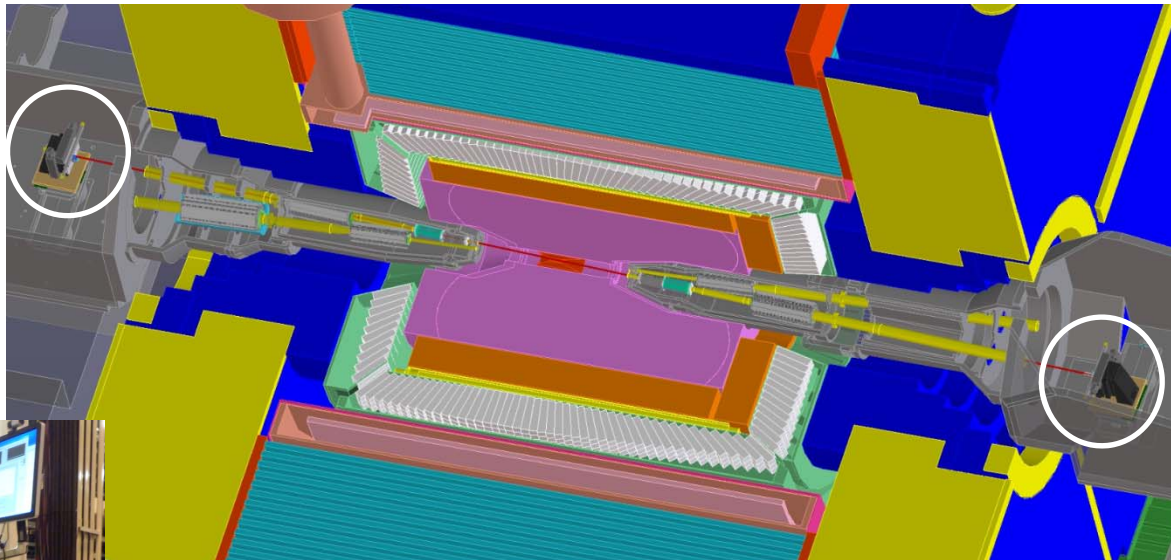
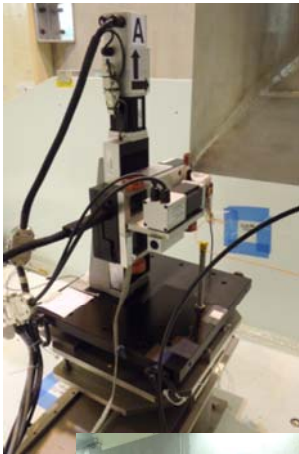

The measured magnetic field alignment data was included in the beam operation.

# For the future operation of SuperKEKB

- Development of the quadrupole field vibration measurement system by **BNL and KEK (2013-2017)**
  - The measurement of the quadrupole field vibration was originally proposed for the ILC interaction region by BNL. The target beam size of SuperKEKB at the beam interaction point is about 50 nm. The influence of the field vibrations of the final focus quadrupoles was studied, and the luminosity degradation was confirmed.
    - BNL and KEK started the development of the measurement system based on the BNL method with a pick-up coil over 1000 turns.

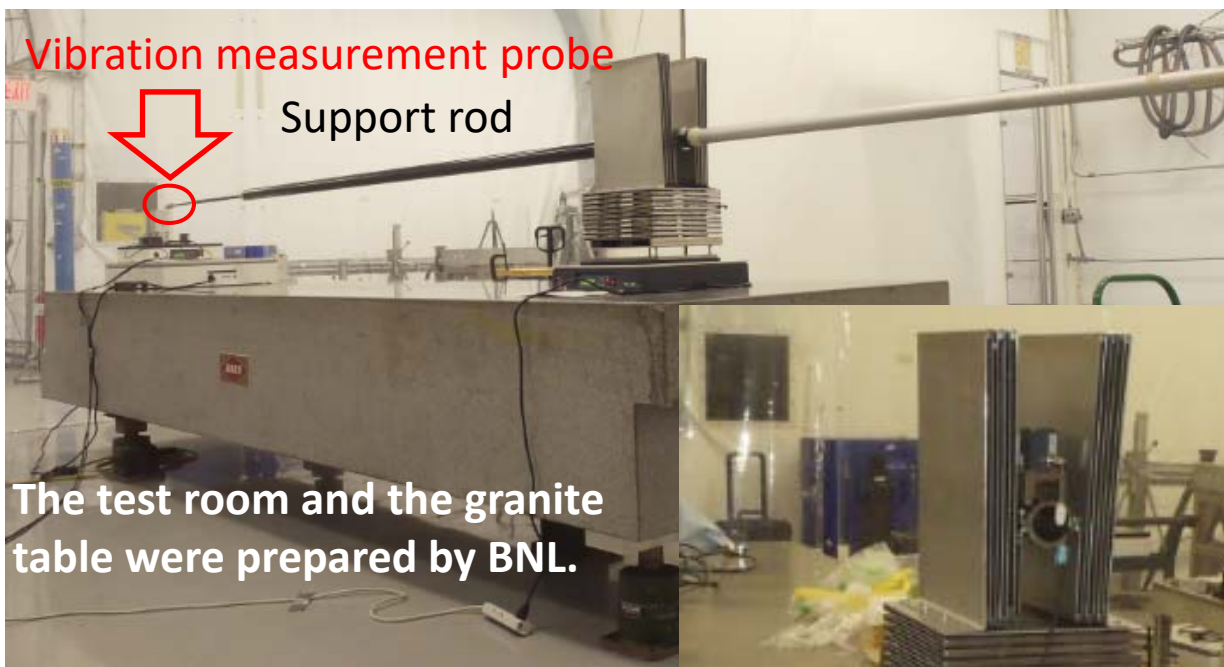
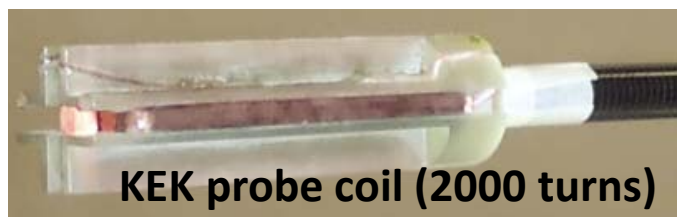

The vibration of the probe in the system was measured by the BNL laser vibrometer. The measured vibration of the probe was about 3 nm.

# Dithering base IP orbit feedback

- Constructing Dithering feedback systems collaborating with SLAC
  - Modulate IP positions and angles with a sinusoidal signal ( $\sim 60\text{Hz}$ ) and detect the frequency and phase response of luminosity monitor using lock-in amplifiers.

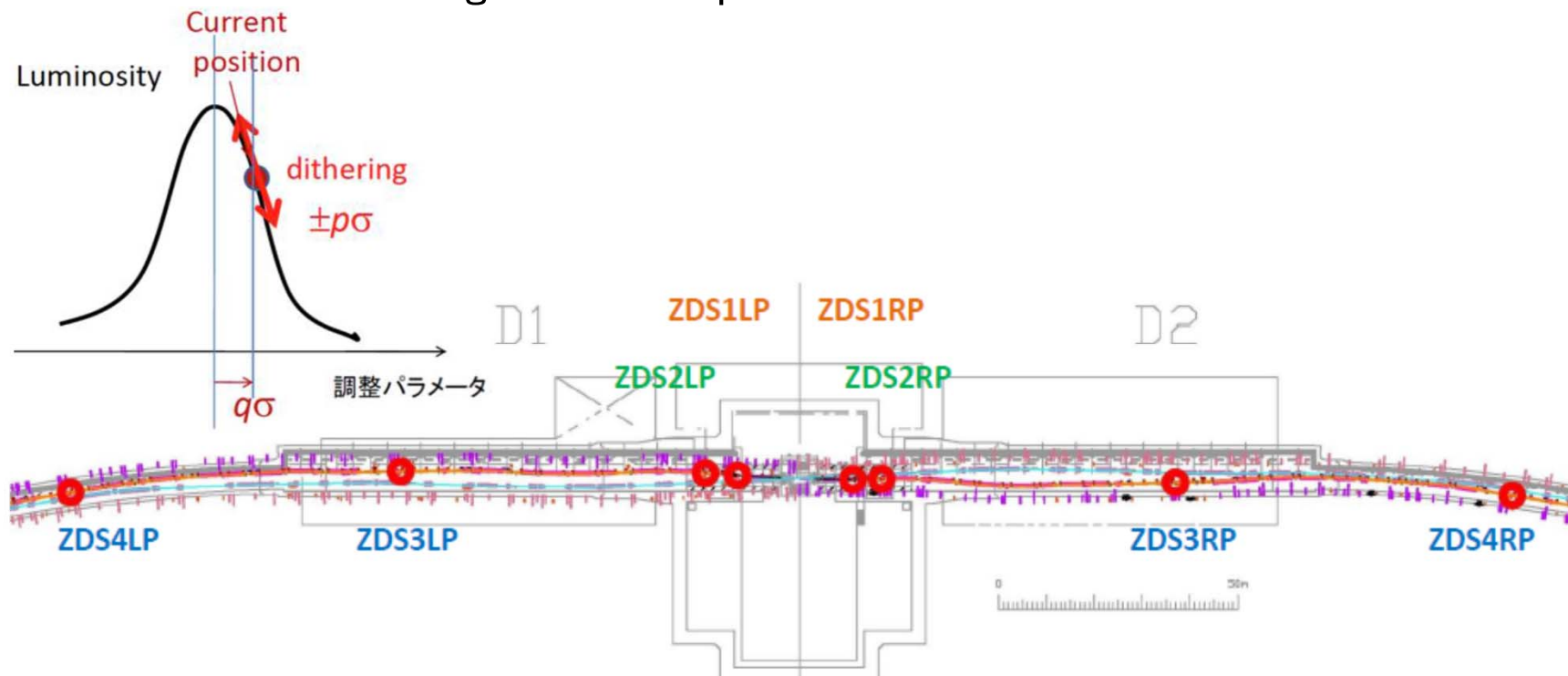

# Progress of FY2018

- **Commissioned the IP dithering system using Phase 2 beam.**
  - U. Wienands (ANL) and A. Fisher (SLAC) joined the commissioning of the systems.
    - Will also join the Phase 3 operation soon.
  - LAL group had contributed the fast luminosity monitor (MNPP-01 project).
  - Bump orbit check, calibration.
  - Selection of dithering frequency
  - Interference with other systems, such as slow orbit feedback, fast beam-beam kick based system, etc.

# Evaluated dithering system with colliding beam

## Beam dither test

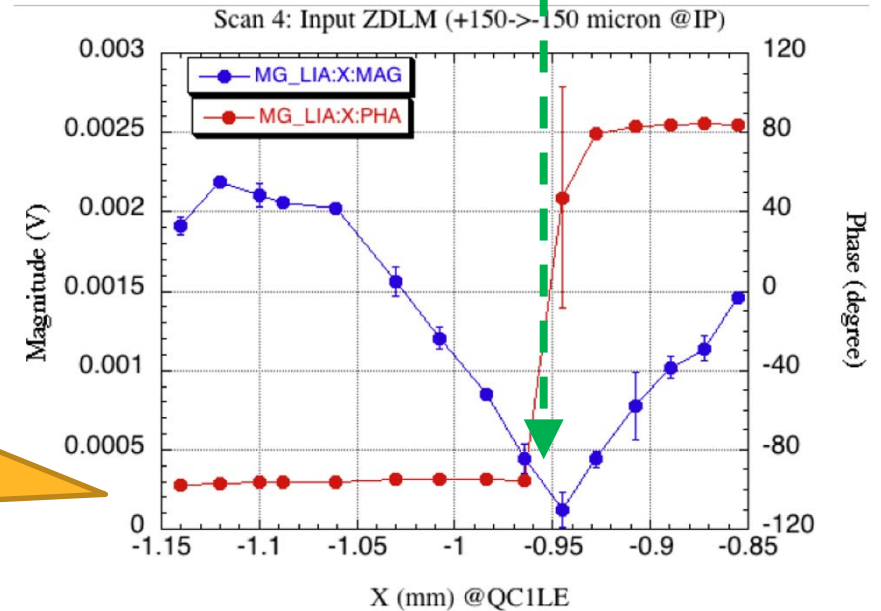
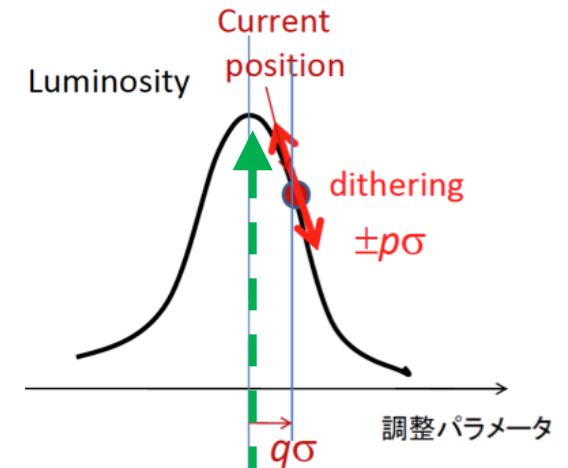
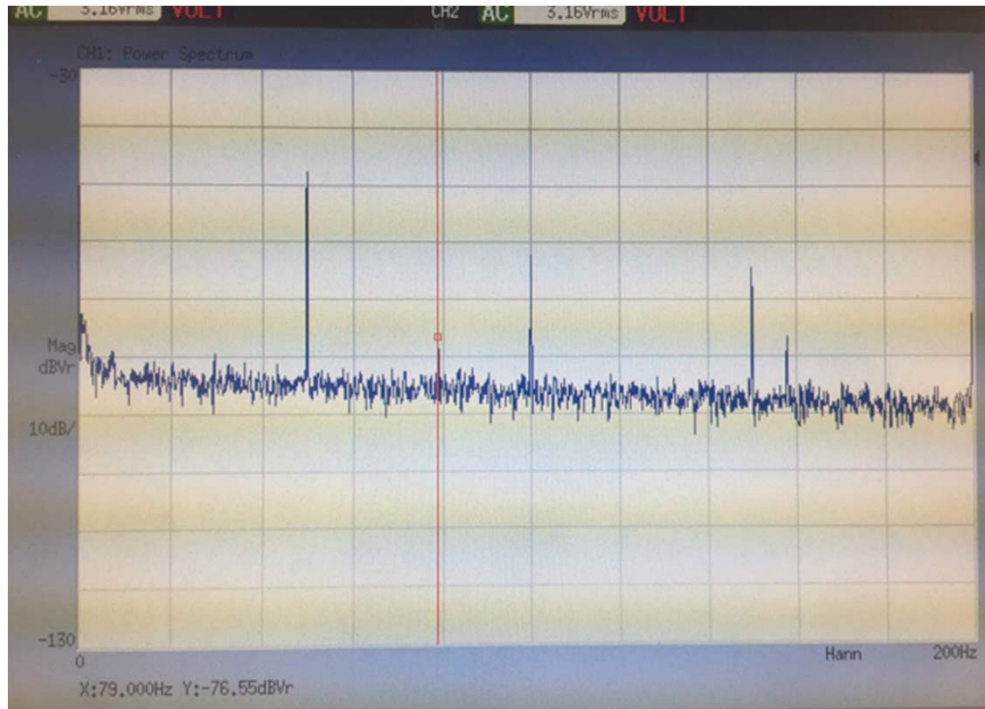

The dither feedback system finds the optimum horizontal offset between the LER and HER to maximize luminosity by determining the minimum  $V_x$



# SuperKEKB: High-Current Feedback Kickers (JFY2015-19)



SLAC (A. Krasnykh, A. Benwell, J. Seeman) started on the design, together with KEK, of the transverse feedback kickers able to withstand  $> 3.5$  A beam current at 5 mm bunch length

- based on the successful kickers from KEKB (1.6A) and PEP-II kickers (3.2 A).
- adapted to SuperKEKB (both x-y rather than single-plane).

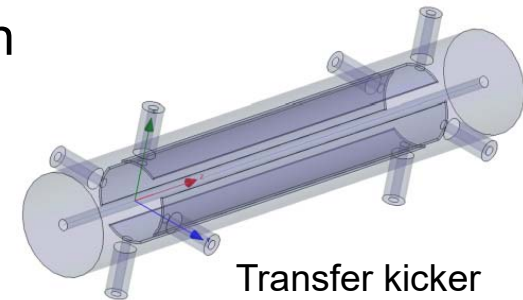

Transfer kicker

SLAC would be willing to build the units.  
Long-standing interest by KEK in this project.

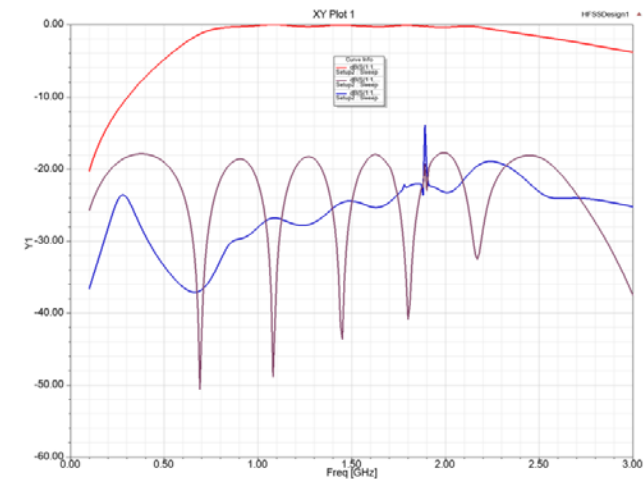

Kicker frequency response  
(A. Krasnykh)

SLAC plans to participate in SuperKEKB beam commissioning as funding allows.

Received DOE funding to work on this project in FY2018-2019.

# SuperKEKB X-Ray Monitor

Detector response to Laser Diode input (red line)

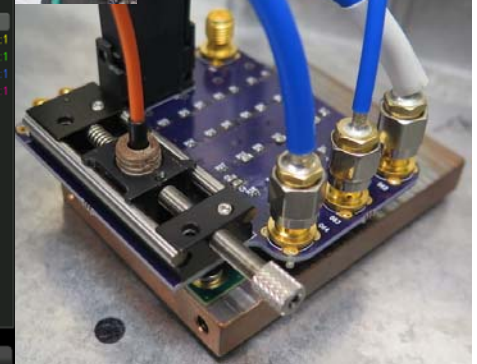
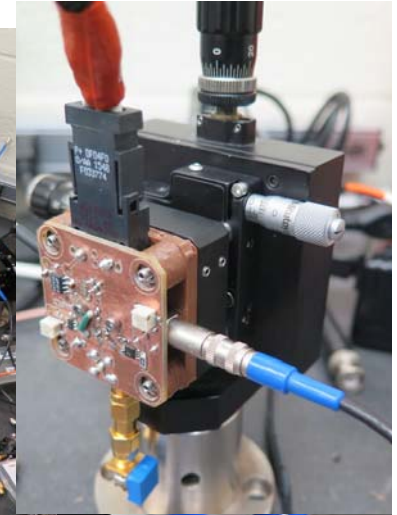
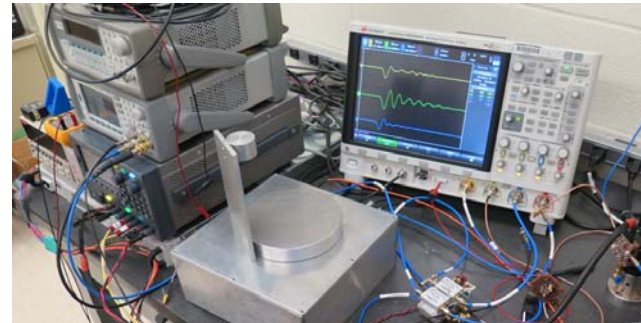
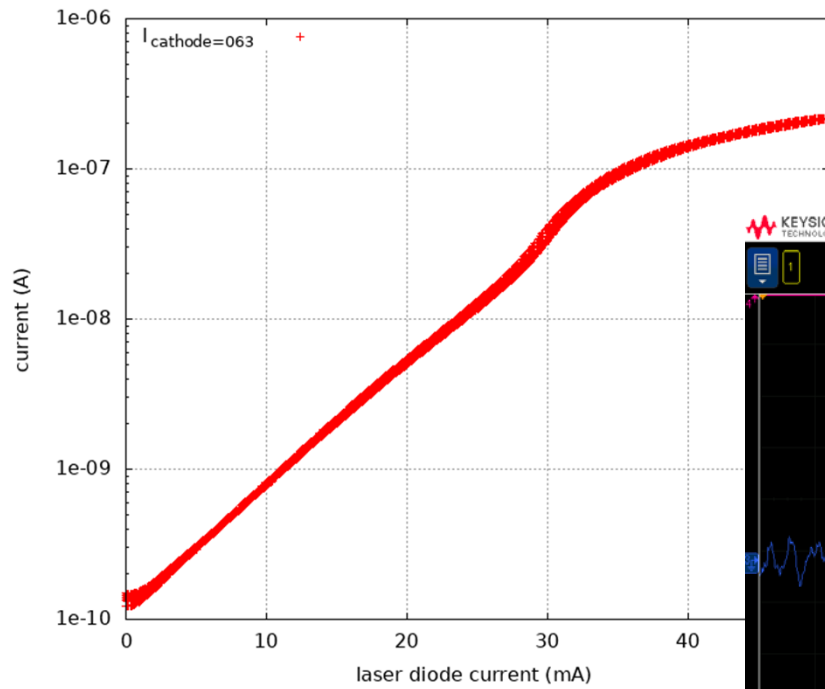

# SuperKEKB X-Ray Monitor 2018

- Amplifier chain:
  - Carefully designing preamp+gain stages
  - Calculation/simulation (noise/gain/recovery time)
  - Prototyping/measurement (network analyzer)
- Firmware/readout:
  - Modified BelleII/TOP firmware to (re)support gigabit ethernet
  - Common ancestor with previous XRM firmware
  - Retains compatibility with Belle-II/TOP firmware and readout software
  - Adding needed XRM functionality to the firmware
- Beamline and studies:
  - Replaced scintillator readout cameras with higher-resolution cameras
  - Implemented horizontal beam size measurements
  - Installed improved helium-delivery system for detector box
  - Replaced beryllium extraction windows



# LABM in 2018–2019 (KEK, Puebla, Sinaloa, Tabuk, WSU)

1) Beamstrahlung clearly seen in both DOWN detectors based on good fills in both polarizations.

Oho Down ( $e^-$ )  
Pol-x and Pol-y  
(1576 and 789  
Bunches)

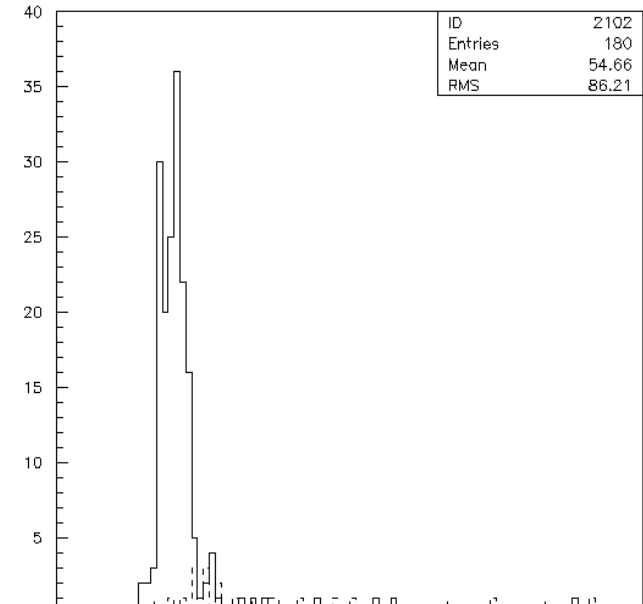
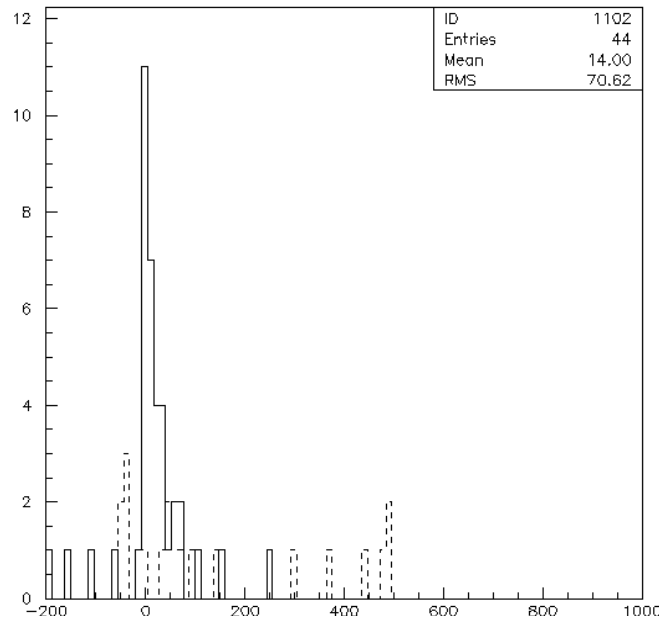

Nikko Down  
( $e^+$ ) P-x and  
P-y (1576,789)

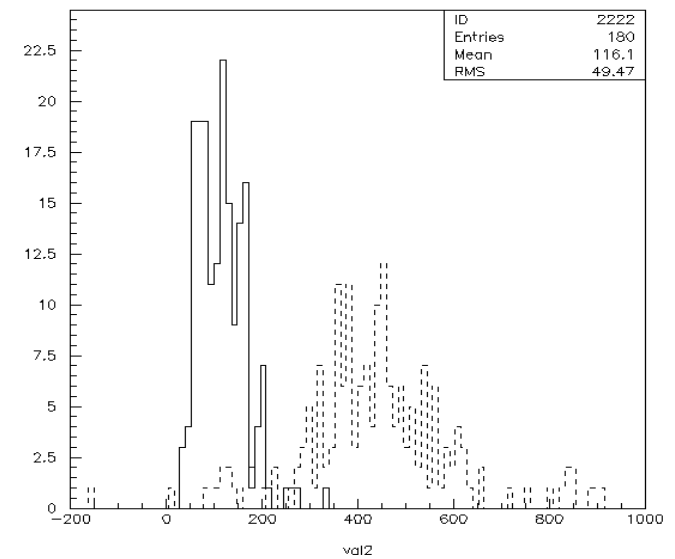
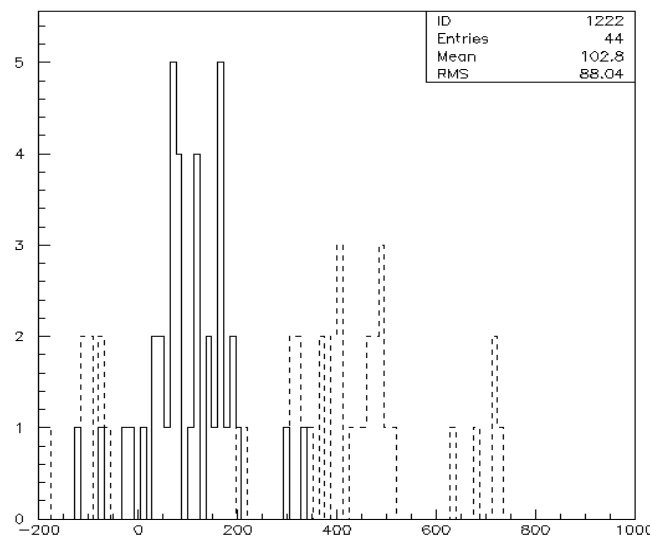

# 2018 Fall activities -Plans for 2019

The two UP telescopes did not see the beam in 2018

Parts were sent to WSU for refurbishing

Shipped back Jan.23 for re-installing Feb. 3

Some changes in Pipes and alignment to half installation time

Braced all non-moving mirrors to improve earthquake resistance

New primary mirrors with bigger mirrors and new transmission

Non-reflective Beam Pipe connectors

Detector to be installed by Feb. 14, expect full functionality this year

With a much more complete event record

# Study on electron cloud (EC)

- Results of FY2018 (1)
    - As a countermeasure against the EC problem observed in Phase-1 commissioning of SuperKEKB LER, units of permanent magnets (PMs) were attached to the beam pipes at drift space of the ring before starting Phase-2, which produce a weak magnetic field in the beam direction.
    - The beam size was measured during Phase-2, and the blow up was not observed up to a linear current density of 0.4 mA bunch<sup>-1</sup> RF-bucket<sup>-1</sup>, which was the twice of that in Phase-1 [1].
- [1] Y. Suetsugu *et al.*, PRAB, 22 (2019) 023201.

Permanent magnets around beam pipes

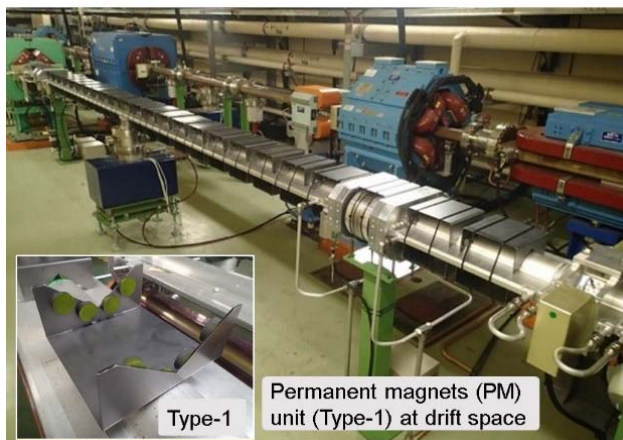

Blow-up of vertical beam sizes in Phase-1 and Phase-2

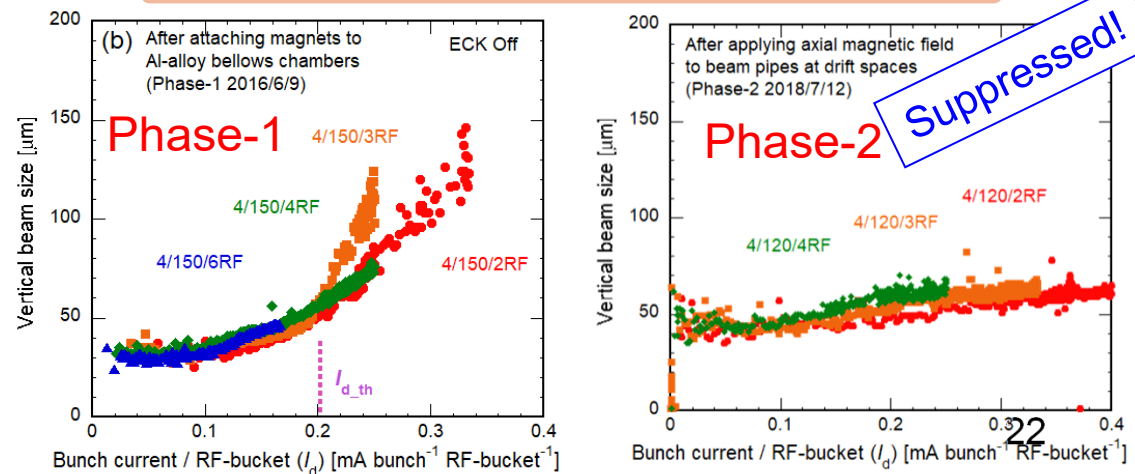

# Study on electron cloud (EC)

- Results of FY2018 (2)
  - Beam test of a DLC-coated beam pipe at FNAL was finished.
  - Manufacturing of a DLC-coated test beam pipe for SuperKEKB was completed in KEK.
  - Manufacturing of a copper beam pipe for test with a chemically-etched inner surface has started in KEK.
  - Secondary electron yields (SEYs) from rough surfaces formed by thermal spray have been continuously measured in a laboratory at KEK. Analysis of the results is on going.

DLC coated beam pipe

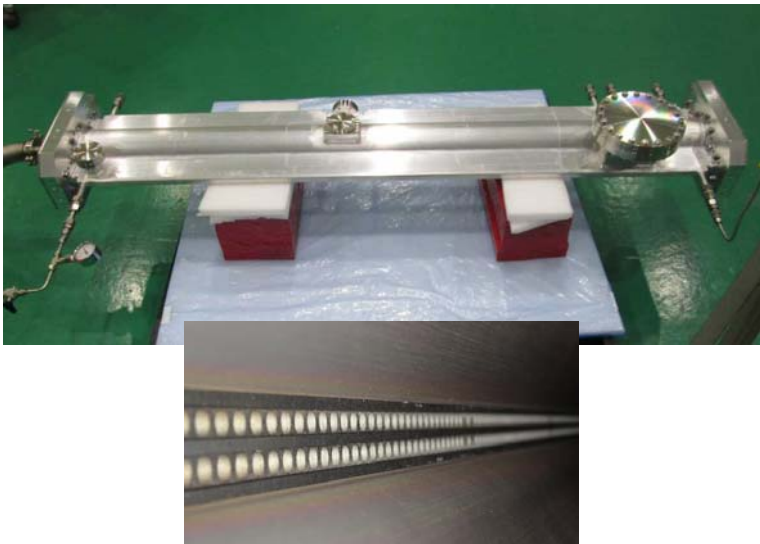

Measurement of SEY from rough surfaces

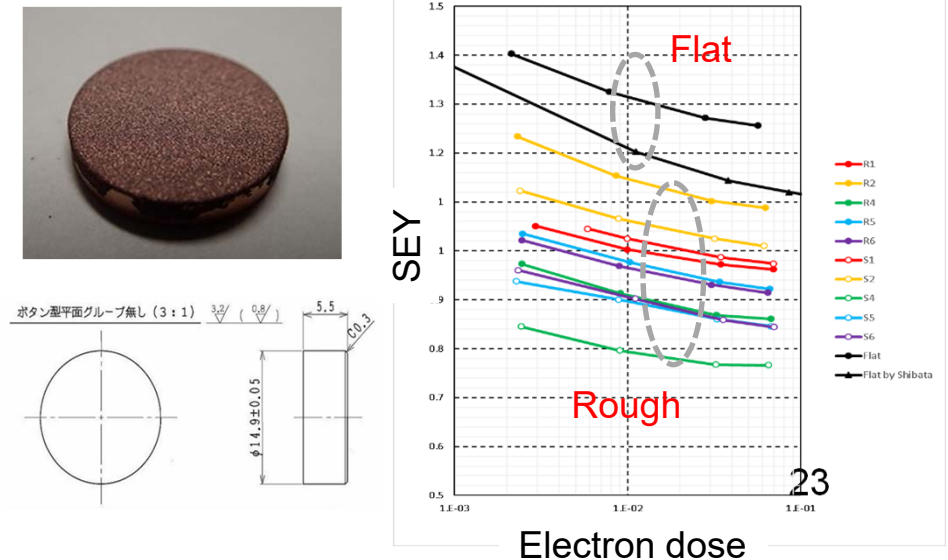

# Development of beam collimators and their related instruments

- Beam collimators: Results of FY2018
  - Beam collimators, which were designed based on the SLAC-type and developed in KEK, have been installed into the SuperKEKB ring.
  - These worked very well during Phase-2 commissioning not only for reducing the background of Belle II, but also for protecting the final-focusing quadrupole magnets (QCS) from the quench.
  - However, the collimator heads were damaged during Phase-2, and the countermeasures are to be considered in the future [1].

[1] Y. Suetsugu *et al.*, *JVST-A*, 37 (2019) 021602.

Vertical type collimator (D02\_V1) installed in the tunnel

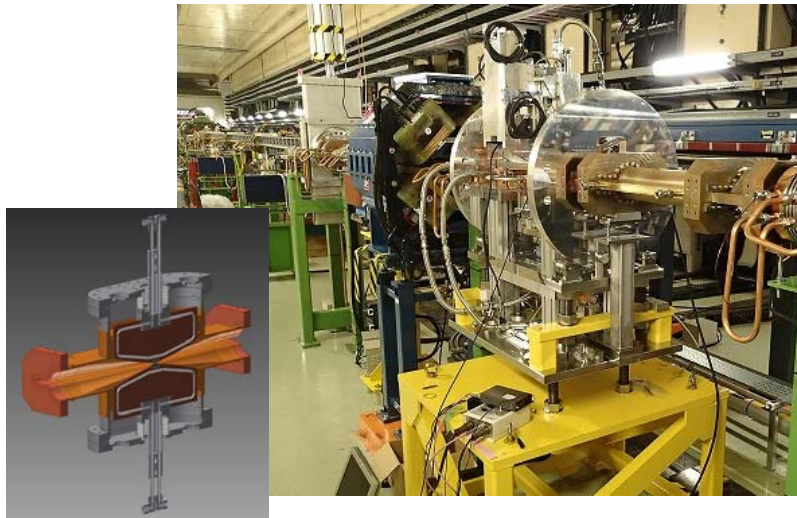

Damage of head (D02\_V1)

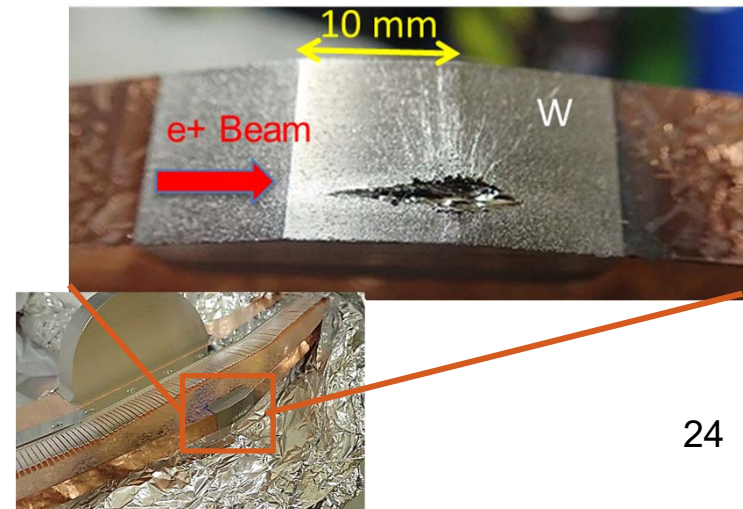



# Development of beam collimators and their related instruments

- Beam collimators: Plan of FY2019
  - Five new beam collimators were installed for Phase-3. The performance will be continuously checked.
  - Instabilities caused by collimators, such as the transverse coupled bunch instability, will be studied during Phase-3.
  - R&Ds on materials and structures to relieve the head damage will start.

Horizontal type collimator (D02\_H1) installed in the tunnel



Collimator system in Phase-3 (Mar.- Jun. 2019)

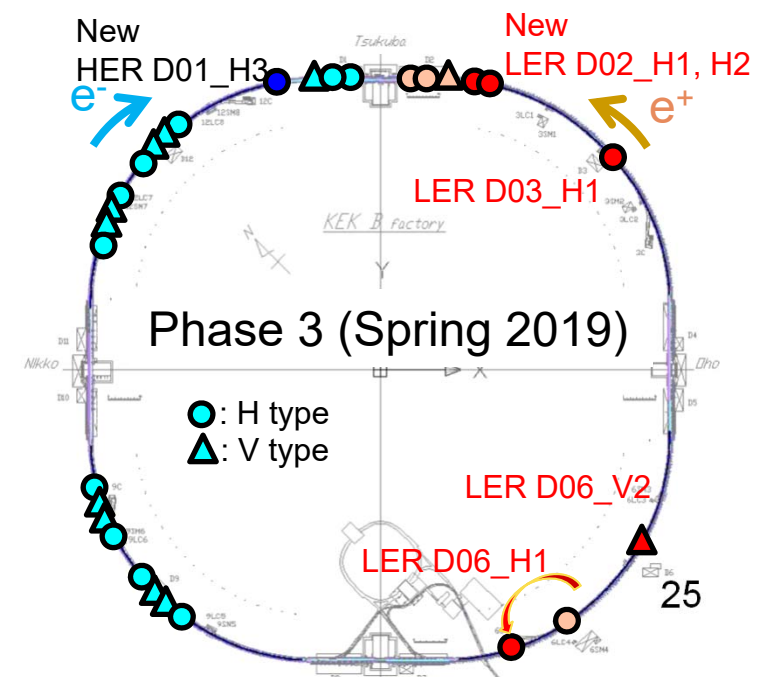

# Accelerator physics activity 2018-

- Coherent beam-beam instability (KEK-US-CERN-China)
  - Beam measurements and simulations have been done in SuperKEKB.
  - Simulations for Future colliders have been done.
- Optics aberration at IP and its correction (KEK-SLAC-BNL)
  - Optics measurement has been done in SuperKEKB.
  - Simulation has shown luminosity degradation for several optics aberrations.
- Beam-beam effects in Electron-Ion Collider (KEK-BNL)
  - Coherent instability
  - Slow Emittance growth of proton beam
- Code development for GPU (KEK-BNL)
  - The beam-beam code is expected 10 times faster in GPU.
- Spin polarization at SuperKEKB (KEK-US)
  - Design of spin rotator using combined magnet has been done. Feasibility study starts.
  - Develop spin tracking code using Bmad.

# Beam-beam effects in nano-beam collision- Accelerator physics activity

KEK-CERN-BINP-SLAC-BNL-Fermilab

- FCC-ee strong coherent beam-beam instability has been seen in strong-strong simulation for FCC-ee and SuperKEKB

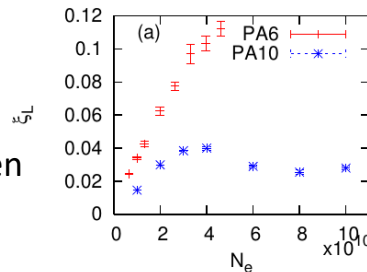
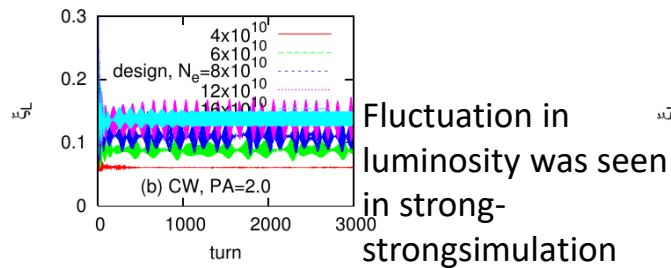

Beam-beam limitation at very low  $\xi$  for high Piwinski angle,

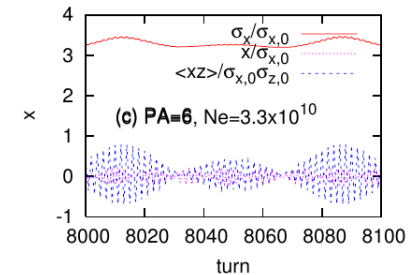

- The instability has been observed in commissioning of SuperKEKB

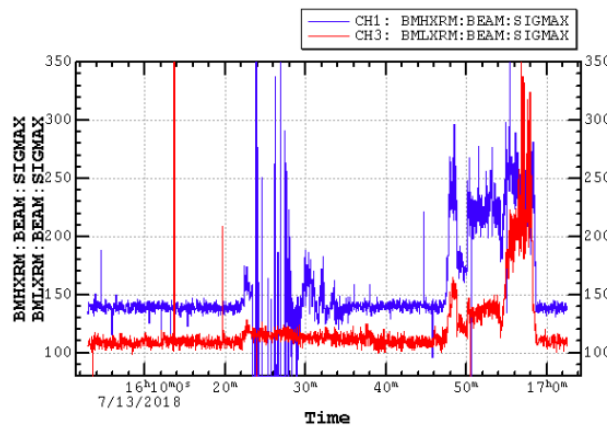

Horizontal beam size blow up was seen in vx scan. Beam size of two beams increase simultaneously.

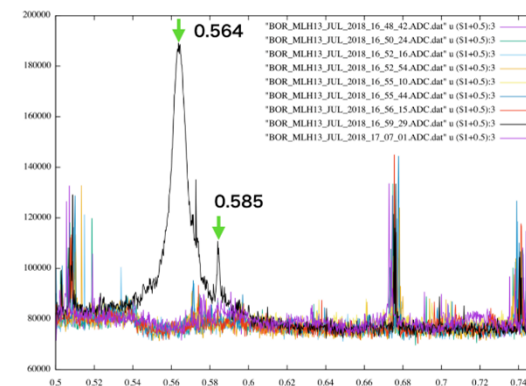

At the size blowup, an oscillation of beam was observed.

# Optics aberration at IP and its correction in SuperKEKB

- Errors in QCS and local chromatic correction section
- First finding- R2(x-y coupling) at IP due to QCS rotation
  - Luminosity increase twice after correction
- Next step toward higher luminosity
  - Measured luminosity is limited at high current
  - Possible errors are chromatic coupling or skew sextupole component at IP

Linear coupling ( $R_2$ )  
correction at SuperKEKB

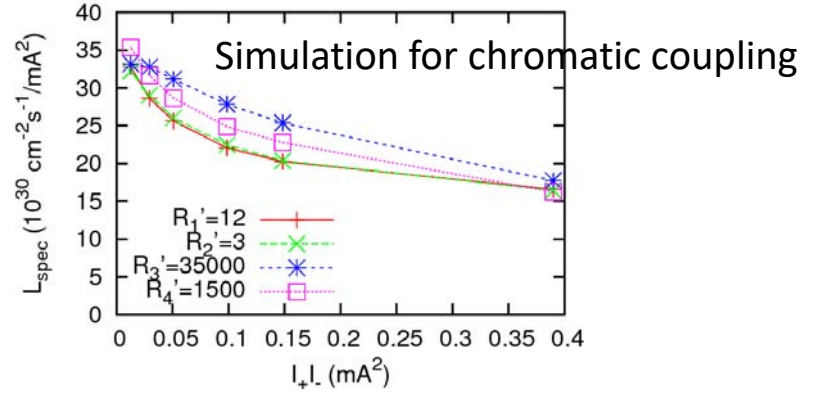
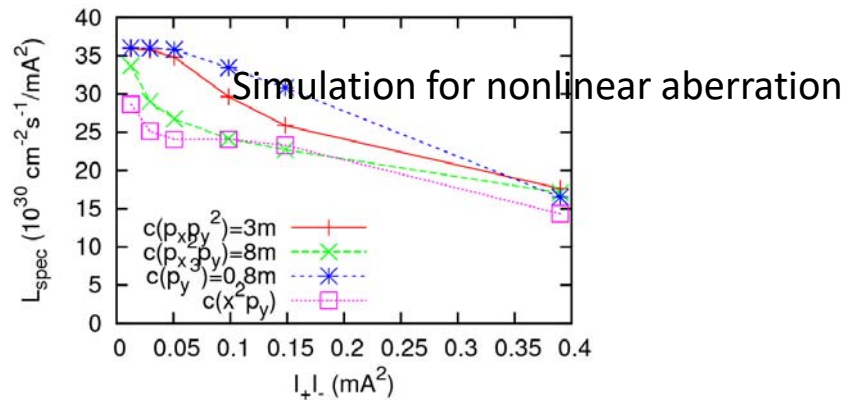
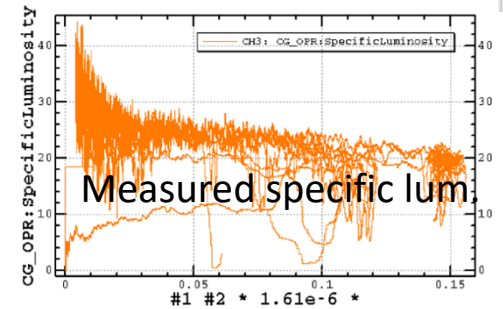
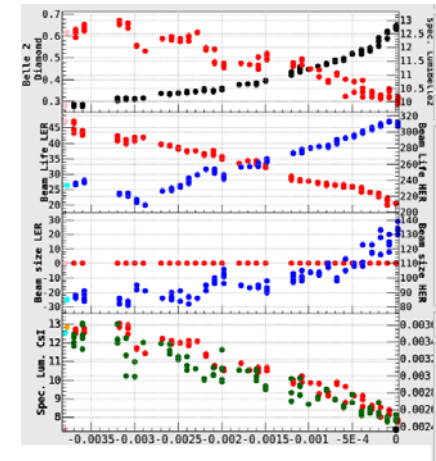

# Research highlight

- Code development for GPU (KEK-BNL)
  - BNL cluster equips NVIDIA GPU
  - The beam-beam code is expected 10 times faster in GPU.
- Spin polarization at SuperKEKB (KEK-ANL-Canada)

## Solenoid Coil Arrangement

- 5.9 m long; 5 cm aperture radius
- Bmad can model magnets like this; so far I use slice models
- Skew quads have different rotation angles.
- Discussed this with B. Parker (BNL): Suitable concept for “Direct Winding” technique.

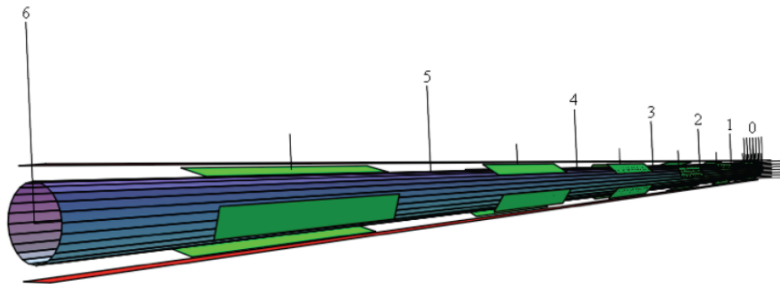

## Lattice Locations for Spin Rotator Solenoid(s)

- Bmad run of sher\_5870:
  - $\pi/2$  point is within BLA4LE # 2, 3.823 m from left
  - the circled dipoles would be replaced by combination magnets

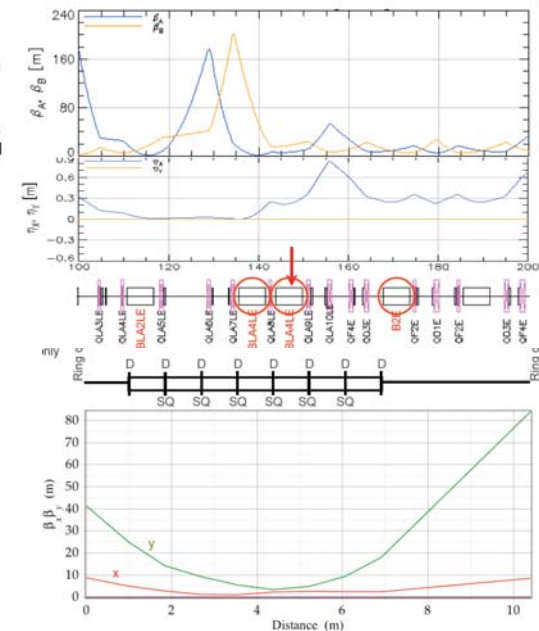

# Overall FY2019 plan

- **Phase 3 commissioning of SuperKEKB**
  - Expecting contributions from SLAC, LAL, IHEP under Multi-National Partnership Laboratory.
- **Extend collaboration with SLAC**
  - Collaboration of FY2013–FY2018 was so successful.
  - SLAC has outstanding experience:
    - PEP-II design and construction.
    - PEP-II high current operation.
    - Strong history of collaboration with KEK
      - NLC/JLC/ILC
      - Bunch feedback and beam diagnostics systems
      - Beam dynamics, beam-beam, electron cloud, CSR, etc.
    - Strong team of accelerator physicists and engineers
- **Continue collaboration with other laboratories**
  - Cornell, U. Hawaii, FNAL, BNL, Wayne State. Univ. Cal. Pol. JLAB

# Ongoing SLAC Collaborations: US-Japan (KEK)



US-Japan:

- SuperKEKB (2012-2019):
- IP dither commissioning (commissioned at SuperKEKB in 2018)
- IP backgrounds (helping with observed background issues)
- Transverse feedback kicker, bunch by-bunch feedback,
- 8 GHz beam design and data/analysis, x-ray beam size monitors, electron cloud effects, beam-beam effects



Transverse kicker design for SuperKEKB  
June 2018 (A., Krasnykh)

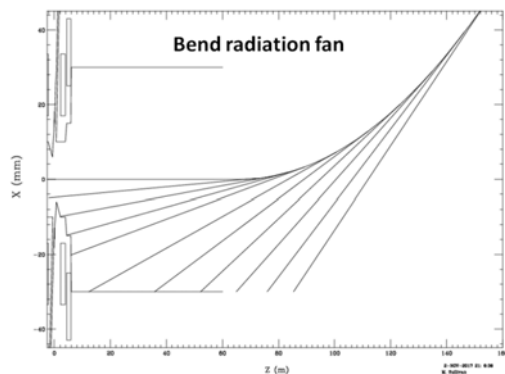

IP beam loss calculations (M. Sullivan)

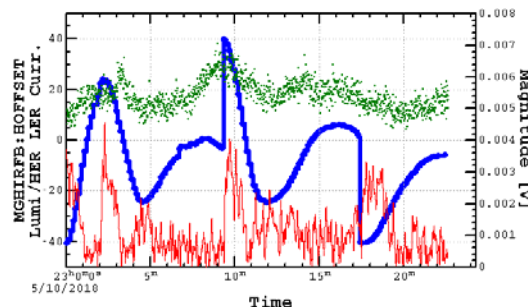

Dither IP feedback  
Commissioning in SuperKEKB  
May 2018 (A. Fisher)

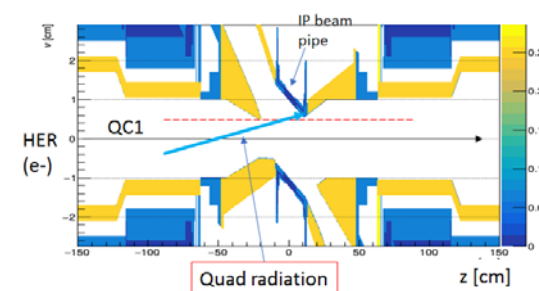

Backgrounds in SuperKEKB (M. Sullivan)

# Backup



# SLAC help with SuperKEKB (2018-2019)



- John Dusatko: Bunch-by-bunch feedback work
- Alan Fisher: IP dither feedback commissioning
- Anatoly Krasnykh: High beam-current transverse bunch-by-bunch feedback kickers
- John Seeman: Collaboration discussions, transverse feedback kickers  
SuperKEKB Accelerator Review Committee, US-Japan global activities
- Michael Sullivan: IR design and background suppression, commissioning  
Belle-2 B-PAC Review Committee  
Focus Review on Belle-2 Vertex Detector  
SuperKEKB Accelerator Review Committee
- Alexander Novokhatski: Higher Order Mode HOM Calculations for Interaction  
Region and vacuum chambers
- Glen White: Collider IR optics issues

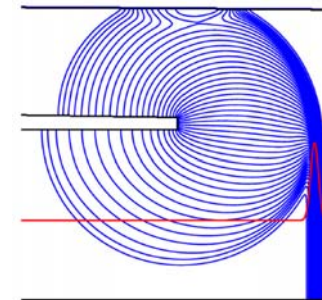

IR bunch HOM simulations and heating estimations (A. Novokhatski)

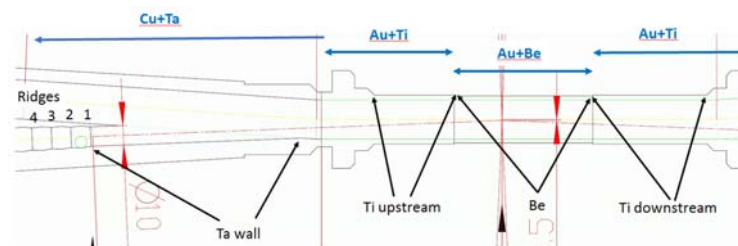

SuperKEKB IR chamber

# Integrated beam dose of Phase 3

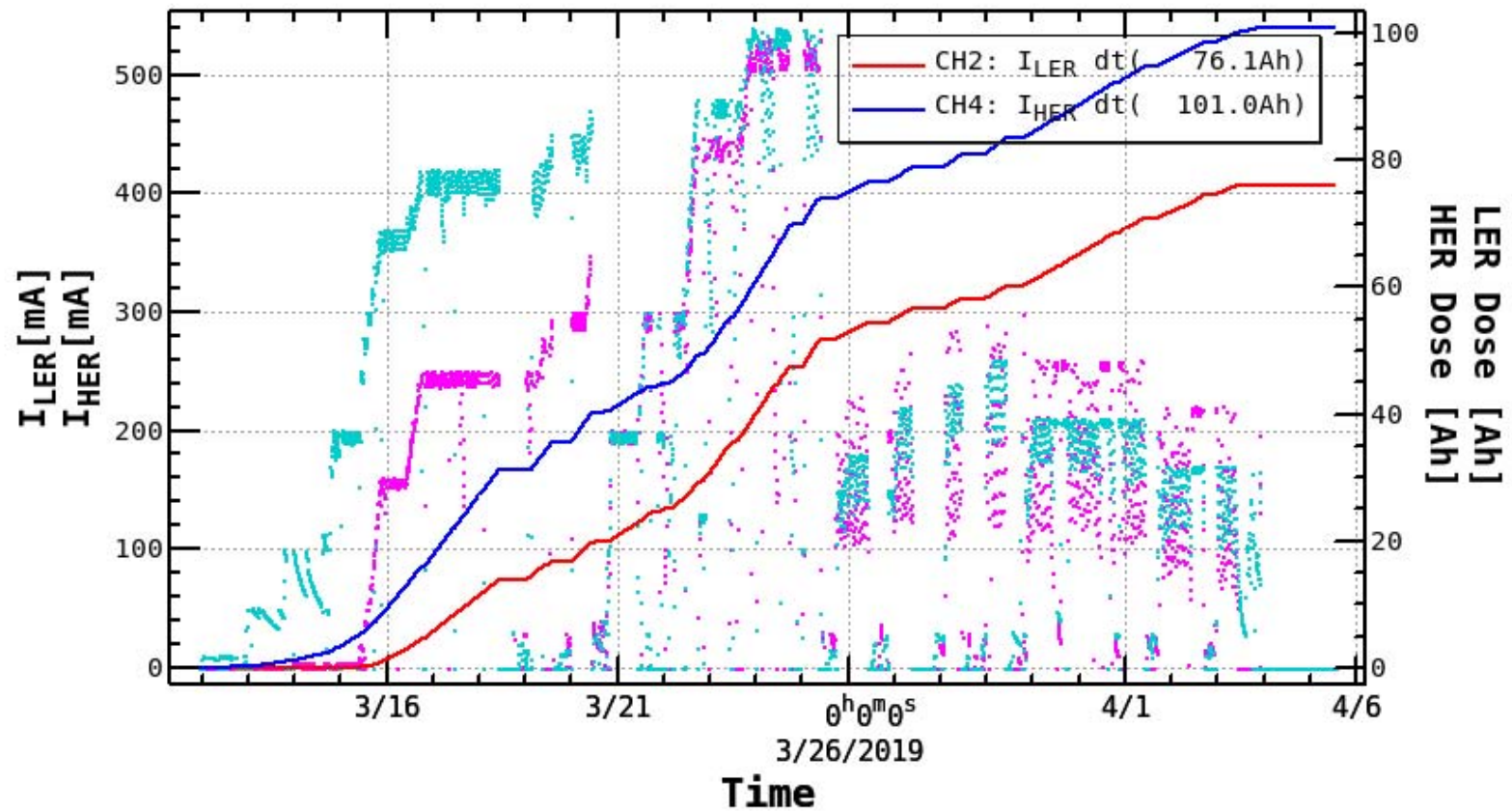

# Study on electron cloud (EC)

- Plan of FY2019
  - Experimental and theoretical studies on EC in the SuperKEKB LER will be continued at higher beam currents. For example, the effect of grooves will be checked by measuring the electron density in a test beam pipe, and the net electron current of clearing electrodes will be measured during Phase-3.
  - Influence of permanent magnets on the beam optics will be studied during Phase-3.
  - A copper beam pipe for test with a chemically-etched inner surface for SuperKEKB will be completed.
  - SEYs from rough surfaces and also grooved surfaces, and their analysis will be continuingly measured in a laboratory at KEK.

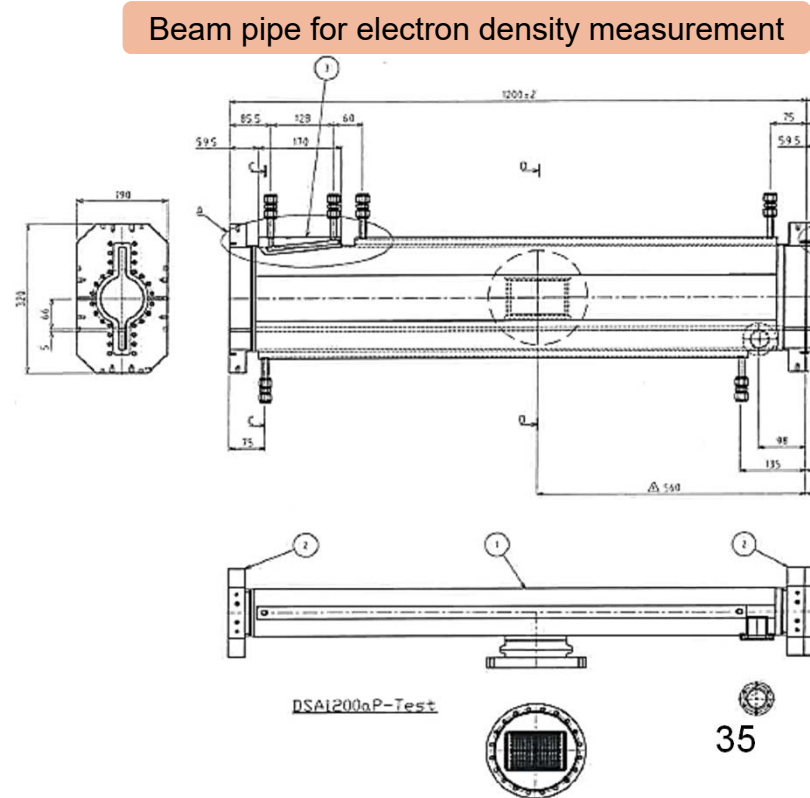

# Development of beam collimators and their related instruments

- HOM absorbers: Results of 2018 and plan of FY2019
  - R&Ds on HOM absorber materials, such as ferrites and SiC, were continuously proceeded.
  - High-power tests using 1.25 GHz microwave were performed using improved ferrite-copper blocks again, but conclusive results have not been obtained yet.
  - Serious consideration of SiC as a HOM absorber material has begun, from a basic brazing test, and will be proceeded further.

Setup for high-power test (Ferrite)

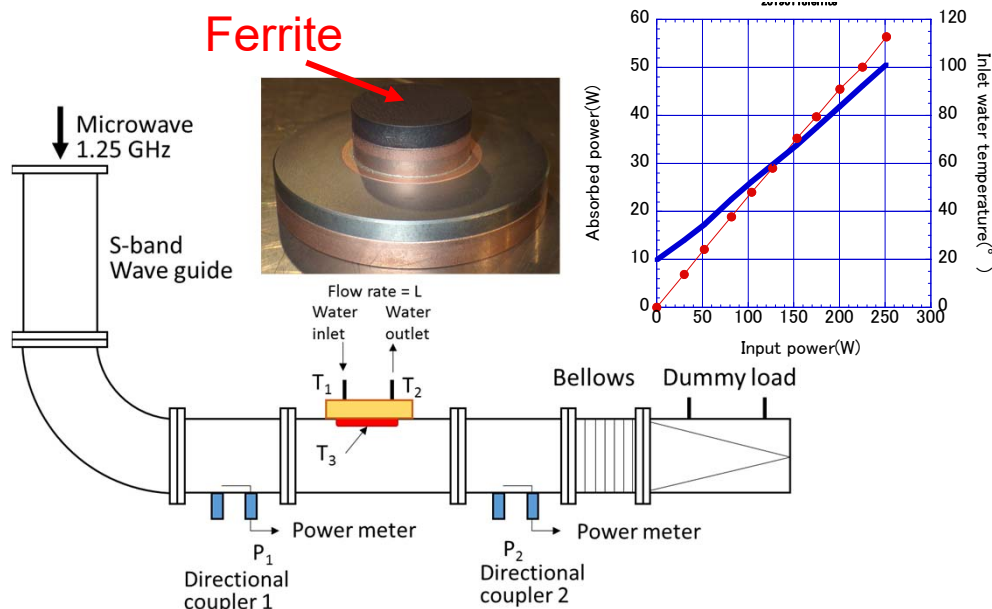

Brazing test of SiC

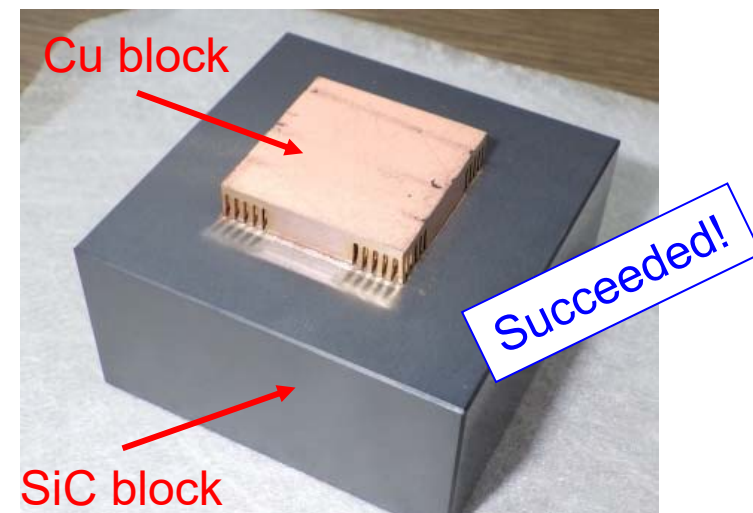

# SLAC Accelerator Research Division ARD: High Energy Collider Accelerators



Local SLAC experts to help with worldwide collider designs and commissioning.

SLAC (2015-2019): Design of e+ Damping Ring and storage ring commissioning

SuperKEKB commissioning (2017-2019): IP dither commissioning, IP backgrounds, transverse feedback kicker, bunch by-bunch feedback, 8 GHz beam data/analysis, x-ray beam size monitors, IP HOM design, IR backgrounds, injection, lattice design

Participants: Y. Cai, A. Fischer, A. Krasnykh, Y. Nosochkov, A. Novokhatski, J. Seeman, M. Sullivan

Publications (selected):

M. Boscolo, M. Sullivan, "Interaction Region Design", PR-AB in process (2018).

A. Novokhatski, M. Sullivan, et al, "Unavoidable trapped mode in the interaction region of colliding beams", PR-AB 20, 111005 (2017) 22, November 2017.

J. Seeman, "Top-Up Injection for a Future Electron-Positron Collider", Proc. of ICFA Workshop ee-Factory", January 2017.

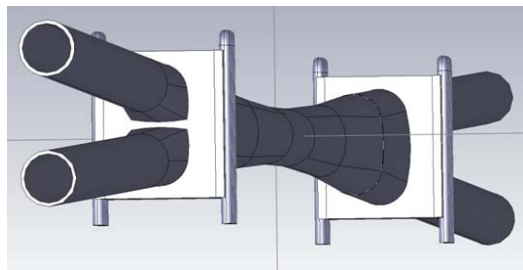

IR HOM Models (A. Novokhatski) (2018)



SuperKEKB dither feedback (A. Fisher)

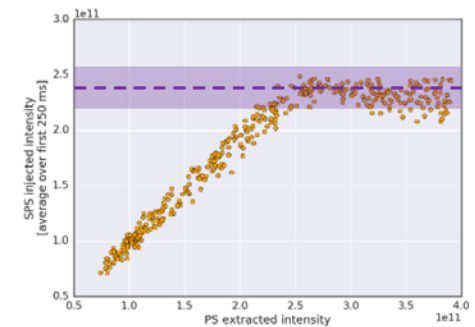

SPS bunch-by-bunch feedback (J. Fox, C. Rivetta)

# SLAC ARD: Support of SuperKEKB, Circular Colliders, US-Japan Contributions



- A) Motivation: Help SuperKEKB commissioning with hope that integrated luminosity will advance faster.
- B) SLAC-AD: Support of SuperKEKB for commissioning, IP dither feedback, collimator, IP backgrounds, beam dynamics (CSR, ECI, beam-beam)
- C) SLAC US-Japan funding from DOE and KEK to work on high power feedback kickers, bunch-by-bunch feedback, x-ray size monitors, commissioning, SRF guns.
- D) SLAC Participants: Y. Cai, J. Dusatko, A. Fisher, A. Krasnykh, A. Novokhatski, J. Seeman, M. Sullivan

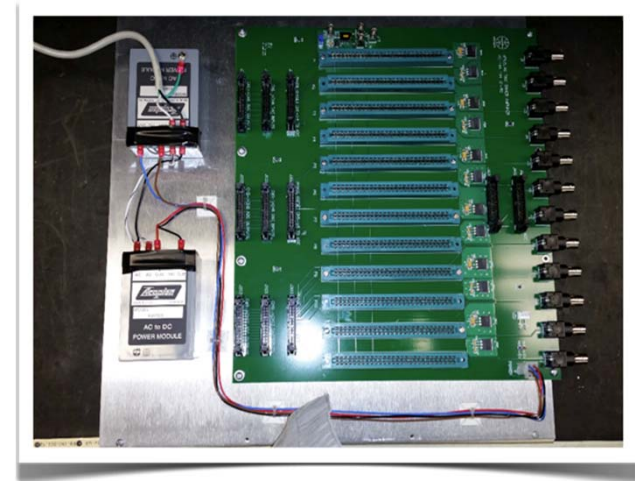

IP dither feedback electronics

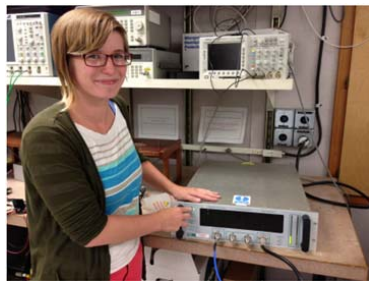

Bunch-by-bunch feedback

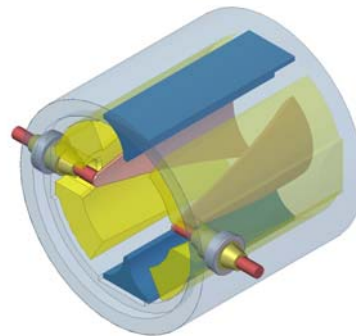

High power (~4 A) feedback kicker design



IP dither feedback coils

# SLAC Contribution to US-Japan R&D Program (June 2018-May 2019)



## A) High speed bunch-by-bunch x-ray beam diagnostics (C. Kenney):

Development of high-speed, bunch-by-bunch x-ray beam diagnostics needed for measuring low-emittance beams and studying beam blow-up due to, for example, electron cloud.

## B) Low level RF control and beam loading (J. Dusatko):

LLRF analysis tools and system development, beam dynamics estimation for circular accelerators with high beam loading with train gaps.

## C) Bunch-by-bunch instability feedback (J. Dusatko):

Development of the next generation of bunch-by-bunch feedback and related systems, including technology for instability control.

## (D) IP dither feedback commissioning (A. Fisher):

Assist in the tune-up stages of IP collision feedback with hardware supplied by US collaborators (SLAC) and new spare components.

## (E) SuperKEKB and background commissioning (M. Sullivan):

Assist general commissioning of the Super KEKB collider including diagnosis of beam instabilities with cures and luminosity optimization.

## F) High power transverse kicker (A. Krasnykh, J. Seeman):

Study low impedance, high beam power feedback kickers.

Kicker HOM Measurements  
(A. Krasnykh)

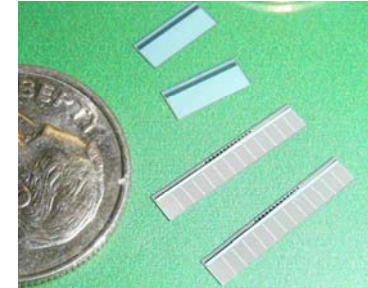

X-ray beam size sensors illuminated edge on (C. Kenney)

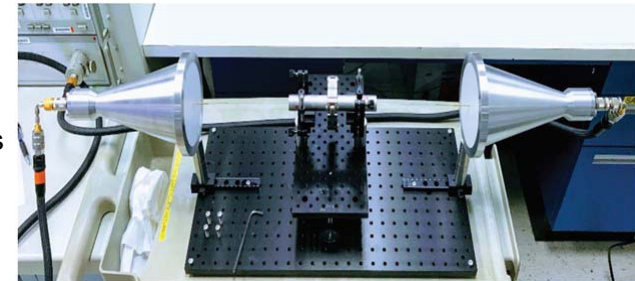

# Interaction Region and IP Beam Pipe

M. Sullivan is on the BPAC review panel and specializes in reviewing the SuperKEKB IR design with reference to beam backgrounds and detector interface.

He carefully monitored the commissioning plans and reviews the BELLE-II planning for initial background measurements.

He goes to KEK about two to four times per year: when the accelerator is starting up, was present in the control room when positrons were being injected into the main ring, and attends two to three technical reviews per year.

Picture on right is of the collision point with the beam pipe for early running. The review committee advice was used to place the initial running detectors shown.

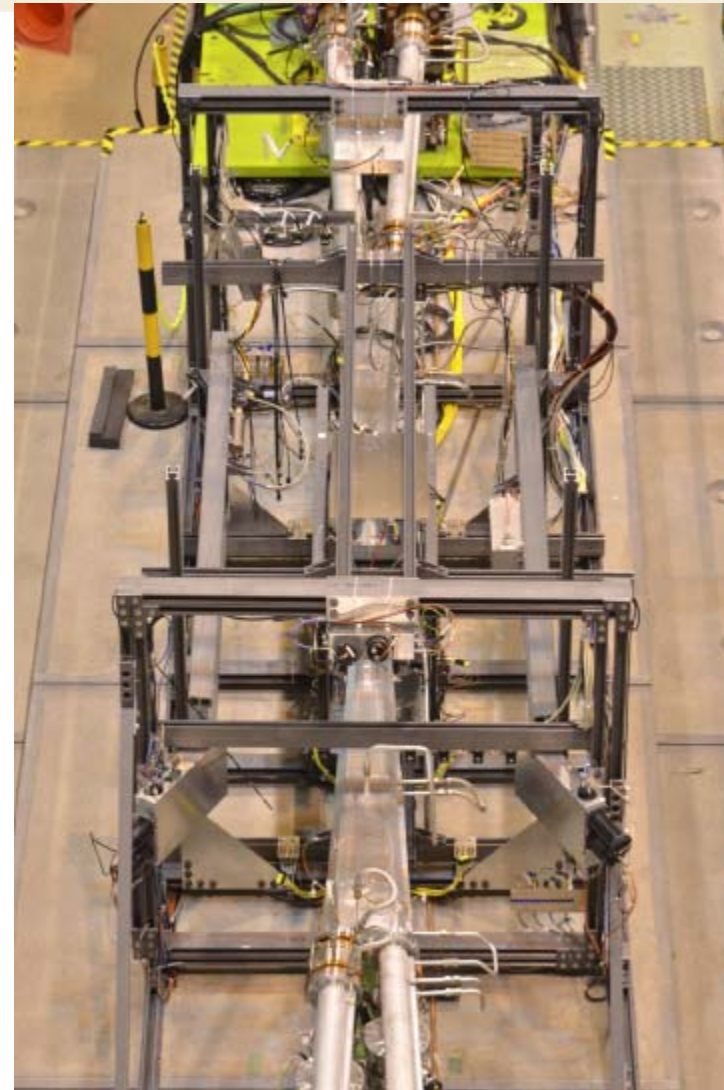

Early SuperKEKB IR background tests