



# Cryomodule Transportation

Brian Hartsell for the Cryomodule Transportation Team

LCLS-II 3.9 GHz CM Delta Final Design Review

January 29-30, 2019



# Outline

---

- Past experience and lessons learned
- Known differences between LCLS-II 1.3 GHz and 3.9 GHz relating to transportation
- Testing and modeling in preparation for 3.9 GHz transport
- Testing using 3.9 GHz cryomodule
- Considerations at SLAC

# Transportation experience

---

- Successfully transported FLASH 3.9 GHz cryomodule from Fermilab to DESY in April 2009.
  - Members from this team are part of the LCLS-II 3.9 GHz transport team.
  - FLASH was a very different transport (multi-modal, international), but ideas were borrowed from this transport.
- LCLS-II 1.3 GHz cryomodules
  - Most recently, successfully transported three 1.3 GHz cryomodules from Fermilab to SLAC after a failed shipment.
  - Members of this team are directly involved with the 3.9 GHz shipping plan.
  - Many lessons learned from this experience are integrated into the LCLS-II 3.9 GHz shipping plan.

# LCLS-II 1.3 GHz shipping: Quick summary

- Cryomodules are transported over the road using an isolation frame mounted on an air ride trailer.



# LCLS-II 1.3 GHz shipping: Quick summary

- Failures during shipping and shipment tests of the cold coupler bellows led to optimization of the transportation system and development of stabilization for sensitive parts.

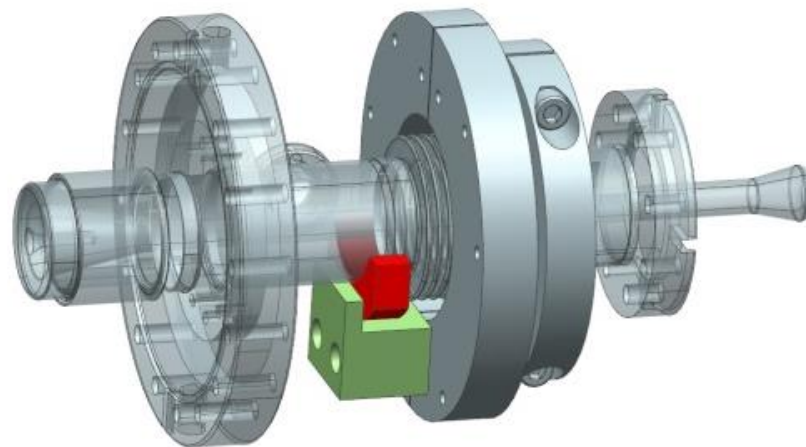
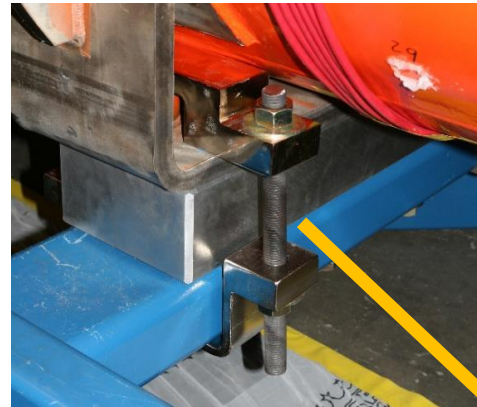
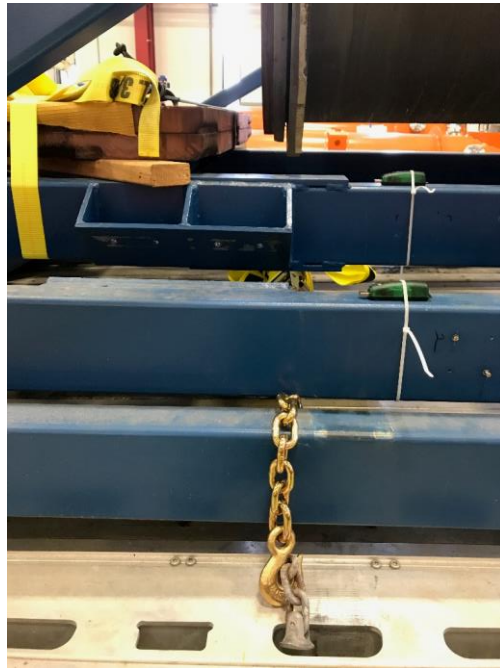

Image and design courtesy Jefferson Lab

# Lessons learned from 1.3 GHz shipping: Frame

- Rigidly fix the isolation frame to trailer.
- Optimize spring selection and placement to provide low resonant frequency and optimal attenuation.
- Stiffen inner frame so springs are effective.
- Use of 'shear plates' to hold CM to the frame.



# Lessons learned from 1.3 GHz shipping: Restrains

- The coupler cold bellows was identified as the source of 1.3 GHz beamline leaks that developed during shipping.
  - Methods to limit movement of this bellows were implemented.
- Cold mass support restraints added.
- Cavity string restraints installed.

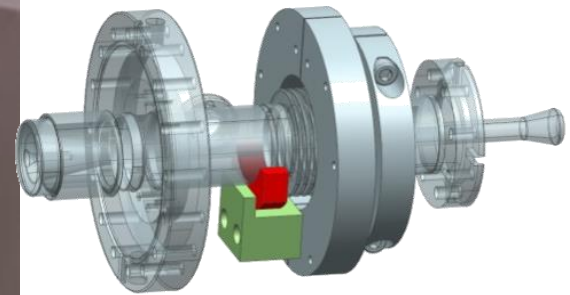
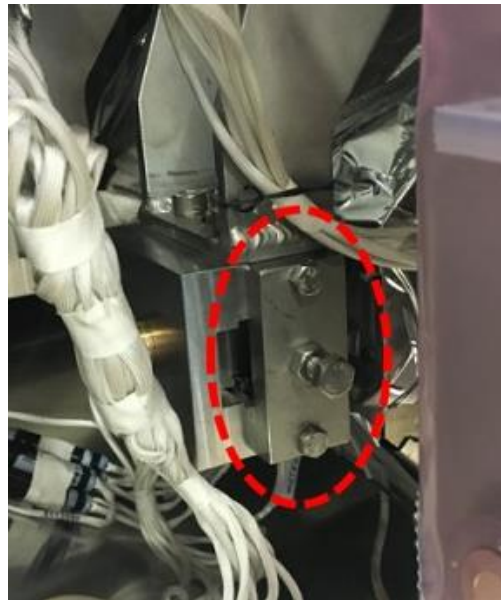
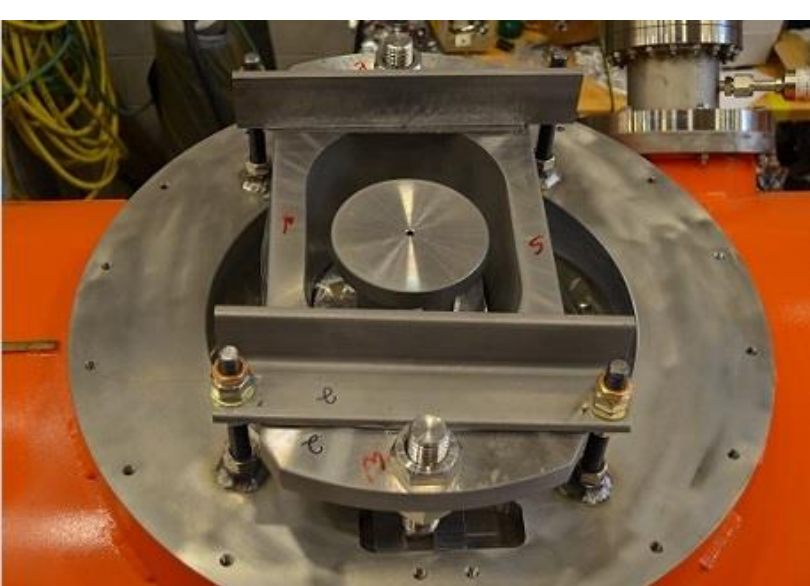

# Lessons learned from 1.3 GHz shipping: Thermal Transients

- Differences in thermal expansion coefficients between the HGRP and vacuum vessel and/or temperature differential between the two leads to possible loss of contact between transport cap and HGRP adapter.
  - Implemented spring washers in the transport cap.
  - Install blankets on the cryomodule.

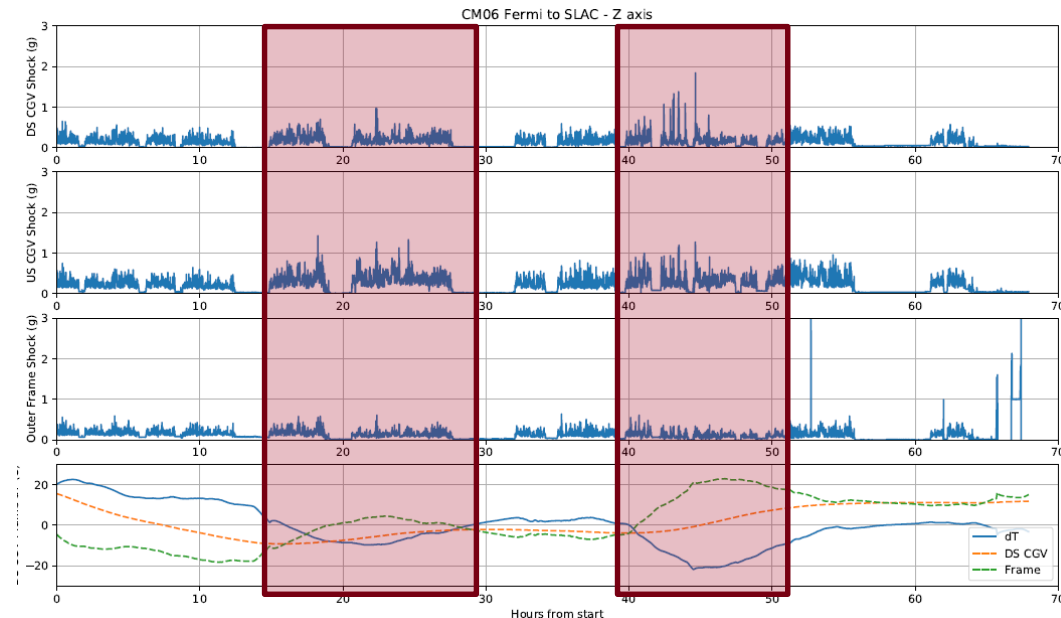
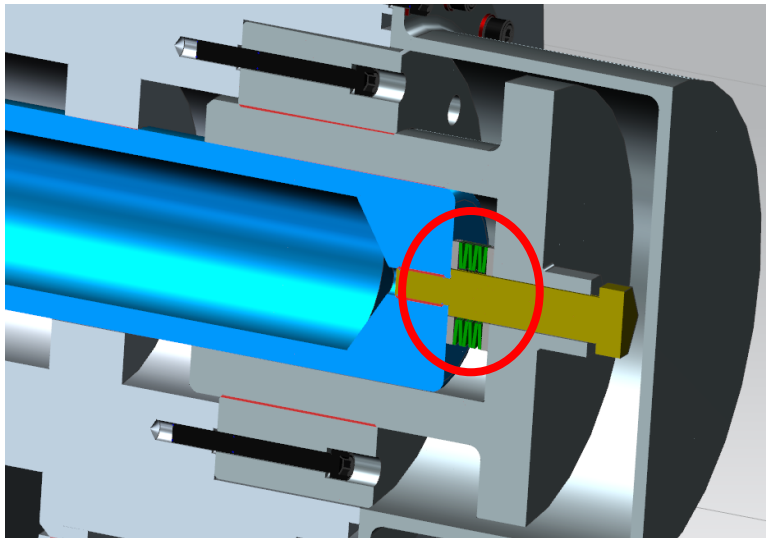



# Lessons learned from 1.3 GHz shipping: Cold mass stabilization

- Planar interface between transport cap and HGRP adapter used for F1.3-06 allowed for movement during thermal contraction or high shock loading
  - Reverted to the XFEL transport system with a conical interface.

LCLS-II used on F1.3-06

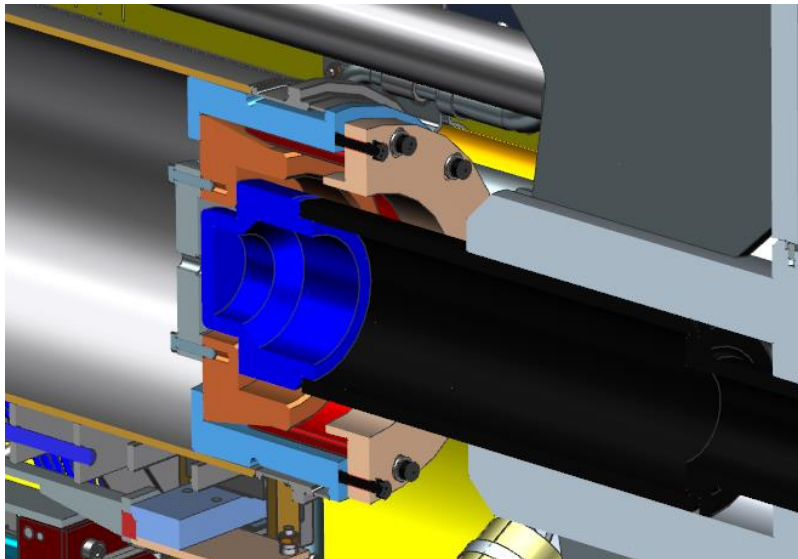

XFEL

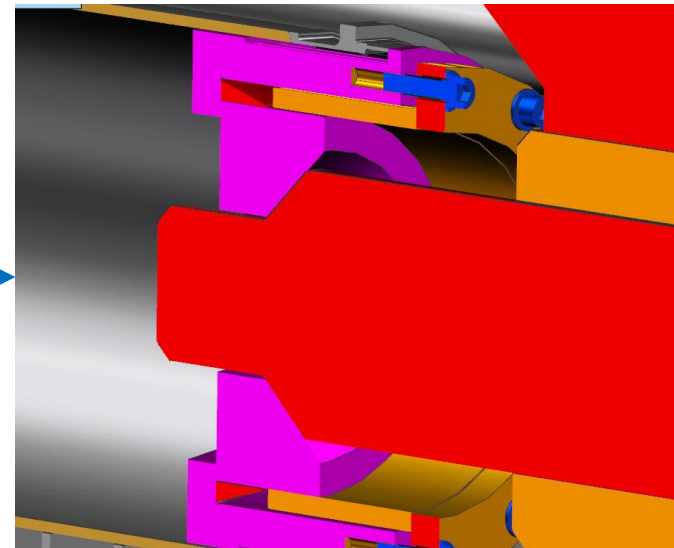

# Lessons learned from 1.3 GHz shipping: Sensors and their placement

- Sensor placement plays a large role in transfer function quality, especially when the frame is relatively flexible.
- Slam Sticks were qualified for use on 1.3 GHz shipments.



## Lessons learned from 1.3 GHz shipping

---

- Incorporate testing with a dummy load as much as possible.
  - When a real cryomodule is not needed, do not use it.
- Integrate offline testing (shaker table, fatigue, modal, etc) during the evaluation of sensitive components.
- Lessons learned from 1.3 GHz shipping will be applied to 3.9 GHz shipping.

# Differences between LCLS-II 1.3 GHz and 3.9 GHz cryomodules

- Tom N. will lead an internal “fresh look” at the design from a transportation perspective:
  - Evaluate all connection points from the cold mass to the cryostat for possible sensitive components.
  - Evaluate assembly for issues that can be mitigated by design.
    - Long lever arm in the spool has already been identified and corrected.

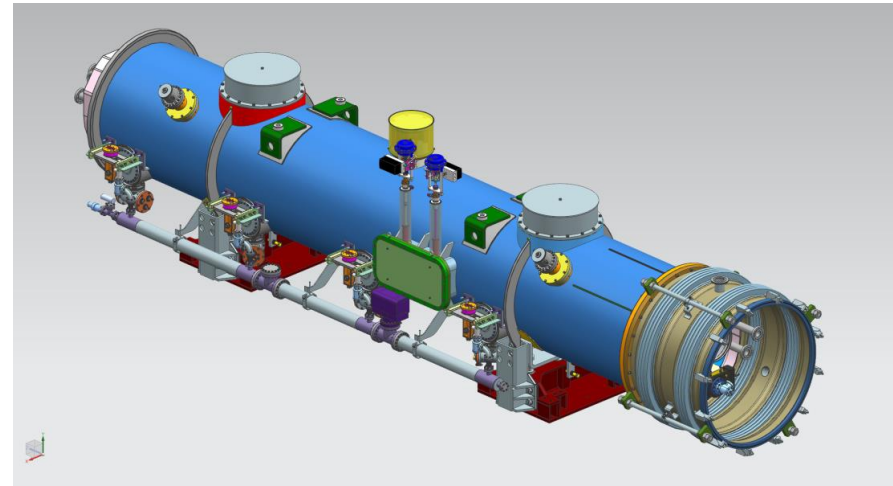
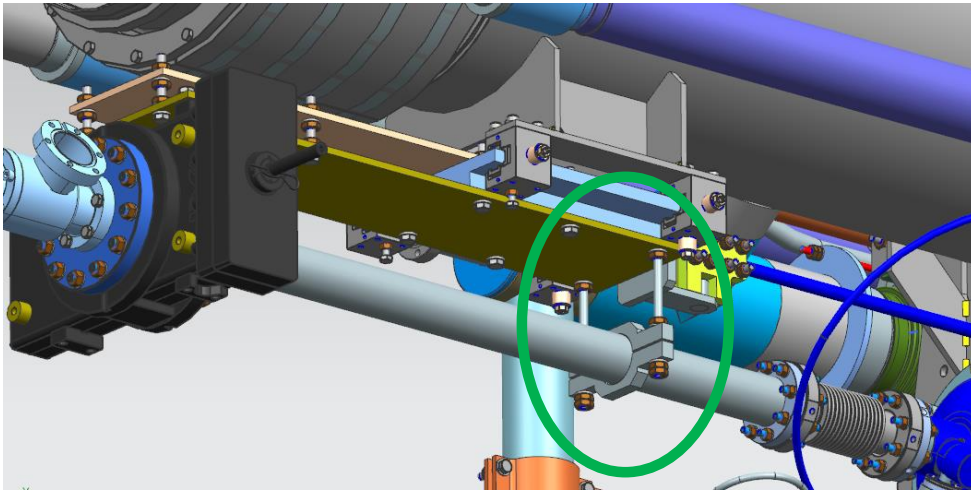

# Differences between LCLS-II 1.3 GHz and 3.9 GHz cryomodules

- Known differences relevant to transport:
  - Different input coupler design.
  - Couplers are on both sides of the CM.
  - No magnet on 3.9 GHz CM.
  - No tuner access ports on 3.9 GHz CM.
    - Restricts access for mounting shock log devices and restraints.

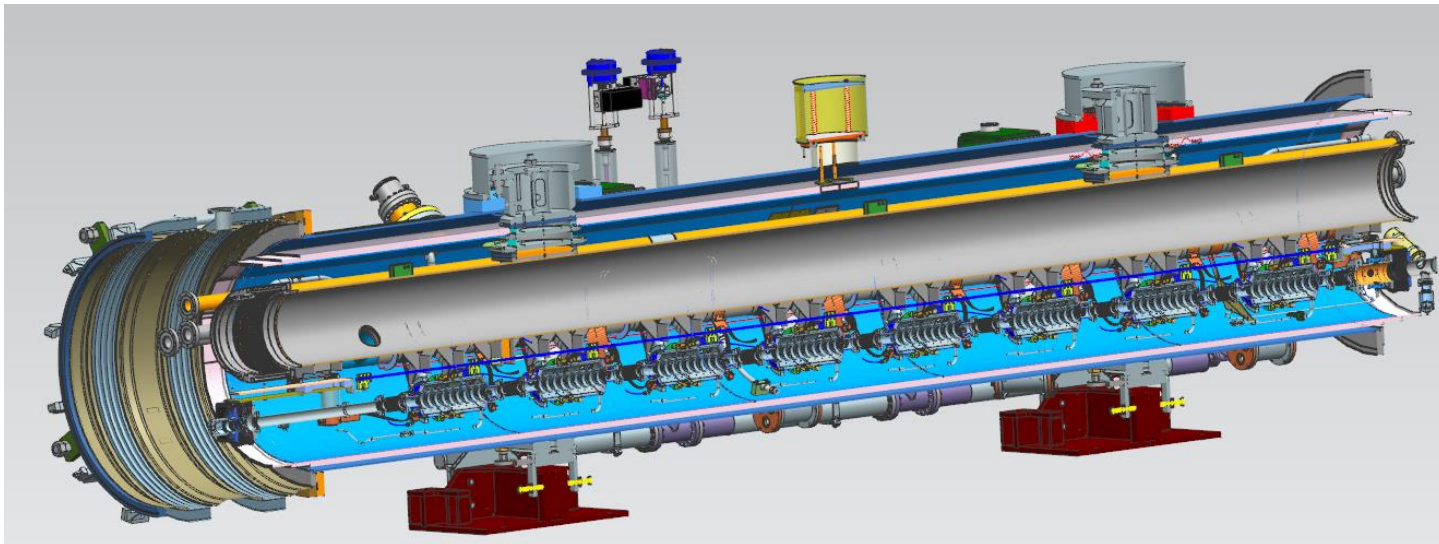

# Preparation for 3.9 GHz transport: Simulations

- Identify sensitive components of 3.9 GHz CM via examination of CAD models.
- Conduct static, dynamic, and modal analyses to look for potential issues:
  - Detailed models of identified sensitive components
    - Input coupler, especially ceramic
    - Beamline bellows
- Thermal analysis to identify any problems with expected thermal gradients during shipment (~20C dT)

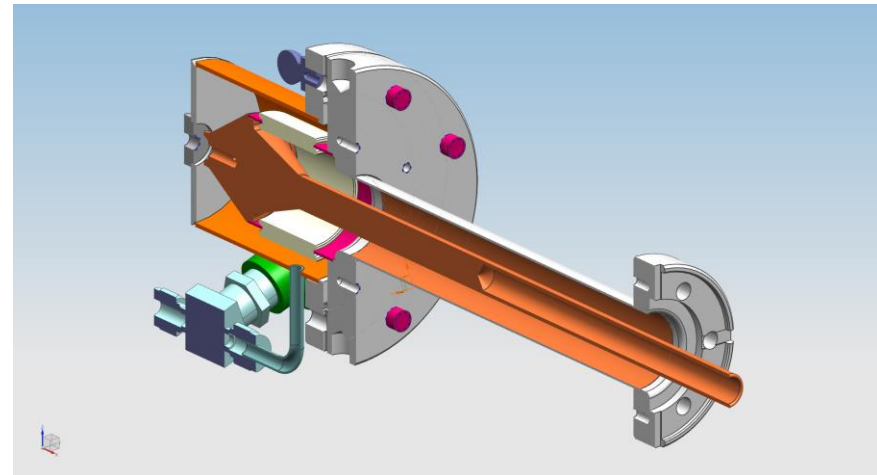

# Preparation for 3.9 GHz transport: Simulations

- Simplified assembly models to help further identify sensitive components.

## Coupler, Tuner (FEM)

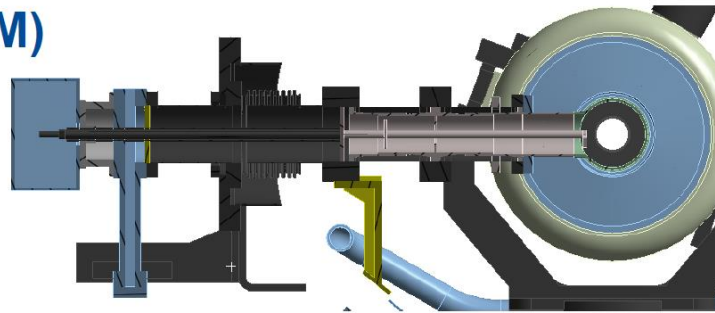

These images are from the 650 MHz cavity cryomodule. (Sergey Cheban)

Needle Support

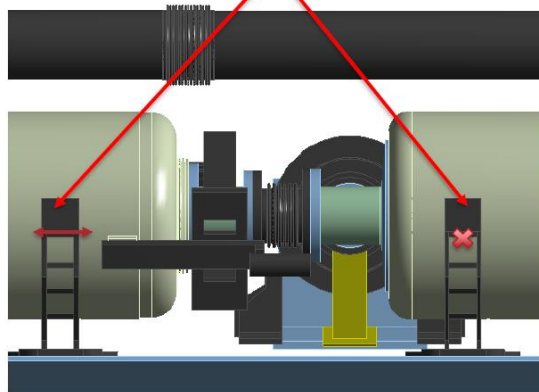

Coupler

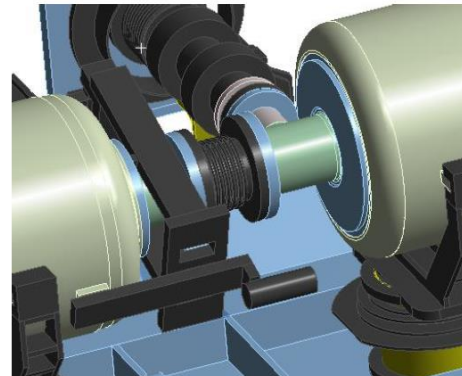

Tuner

# Preparation for 3.9 GHz transport: Simulations

- Example of results

## Mode 1 [11.317Hz]

B: Modal

Total Deformation  
Type: Total Deformation  
Frequency: 11.317 Hz  
Unit: m

0.027385 Max

0.024342

0.021299

0.018256

0.015214

0.012171

0.0091282

0.0060855

0.0030427

0 Min

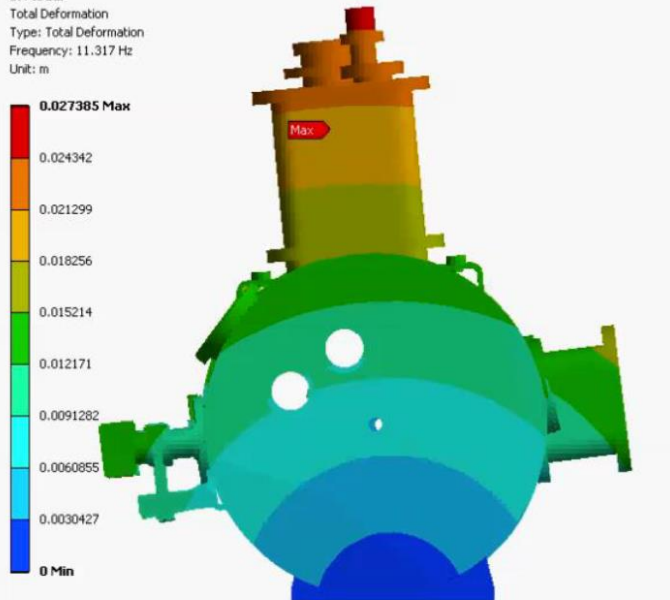

These images are from the 650 MHz cavity cryomodule. (Sergey Cheban)



## Concept for 3.9 GHz transport system

- Re-use 'outer frame' of cryomodule transport frame.
- Fabricate new platforms for mounting the cryomodule.
  - Reduces possible resonant modes from the inner frame.
- Details still pending (sizing of beams, springs used)

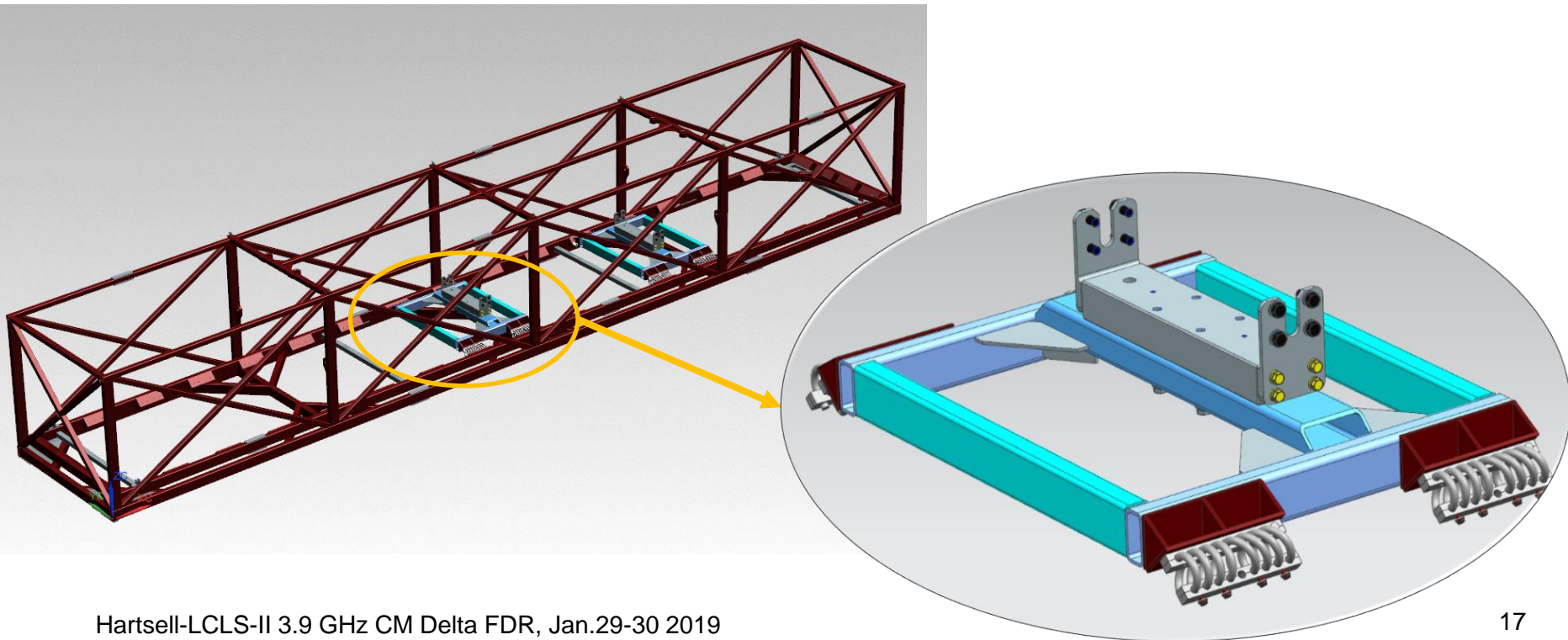

## Concept for 3.9 GHz transport system

- CM sits offset in the frame so that it is centered between the axles and the 5<sup>th</sup> wheel.

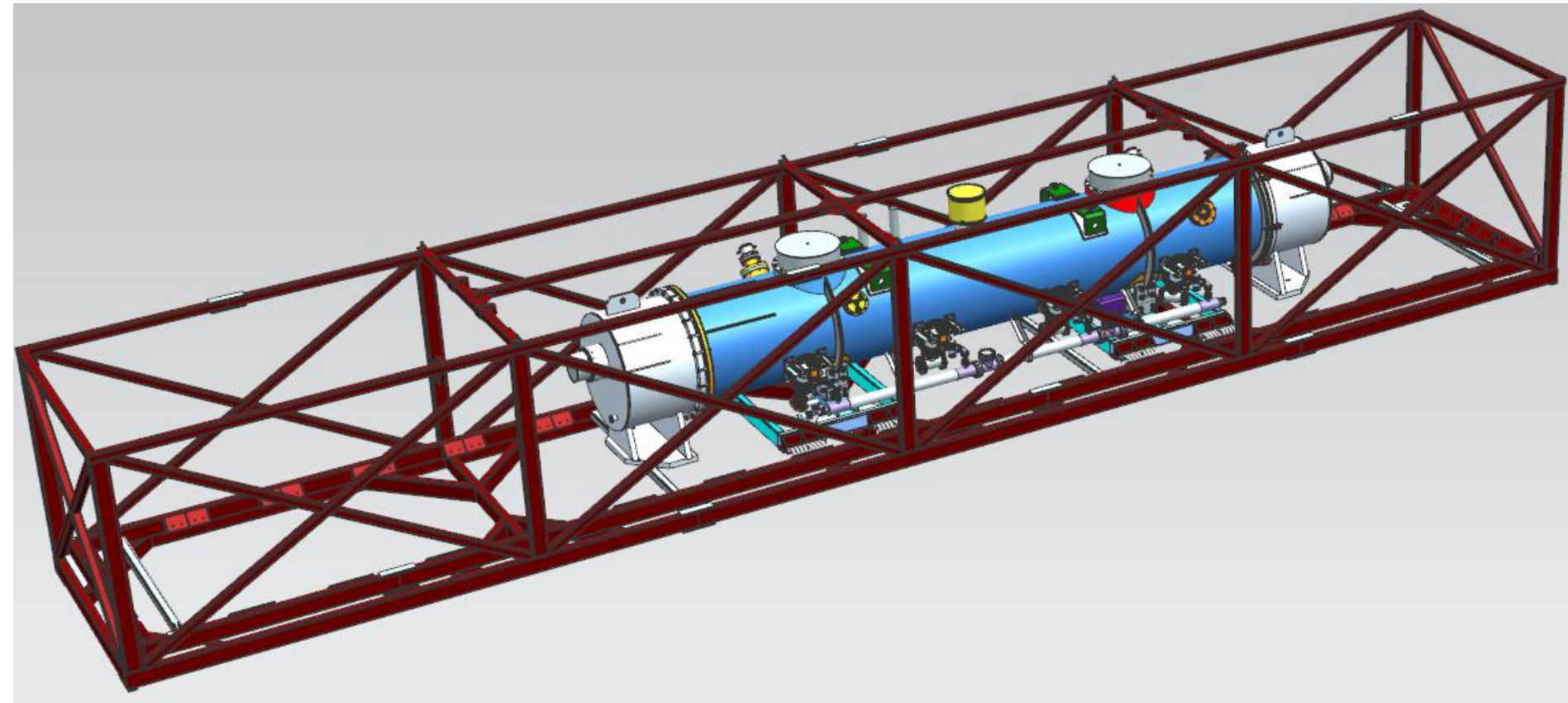

# Concept for 3.9 GHz transport system

- Use XFEL transport caps and HGRP insert for 3.9 GHz with minimal to no modifications needed for cold mass stabilization.

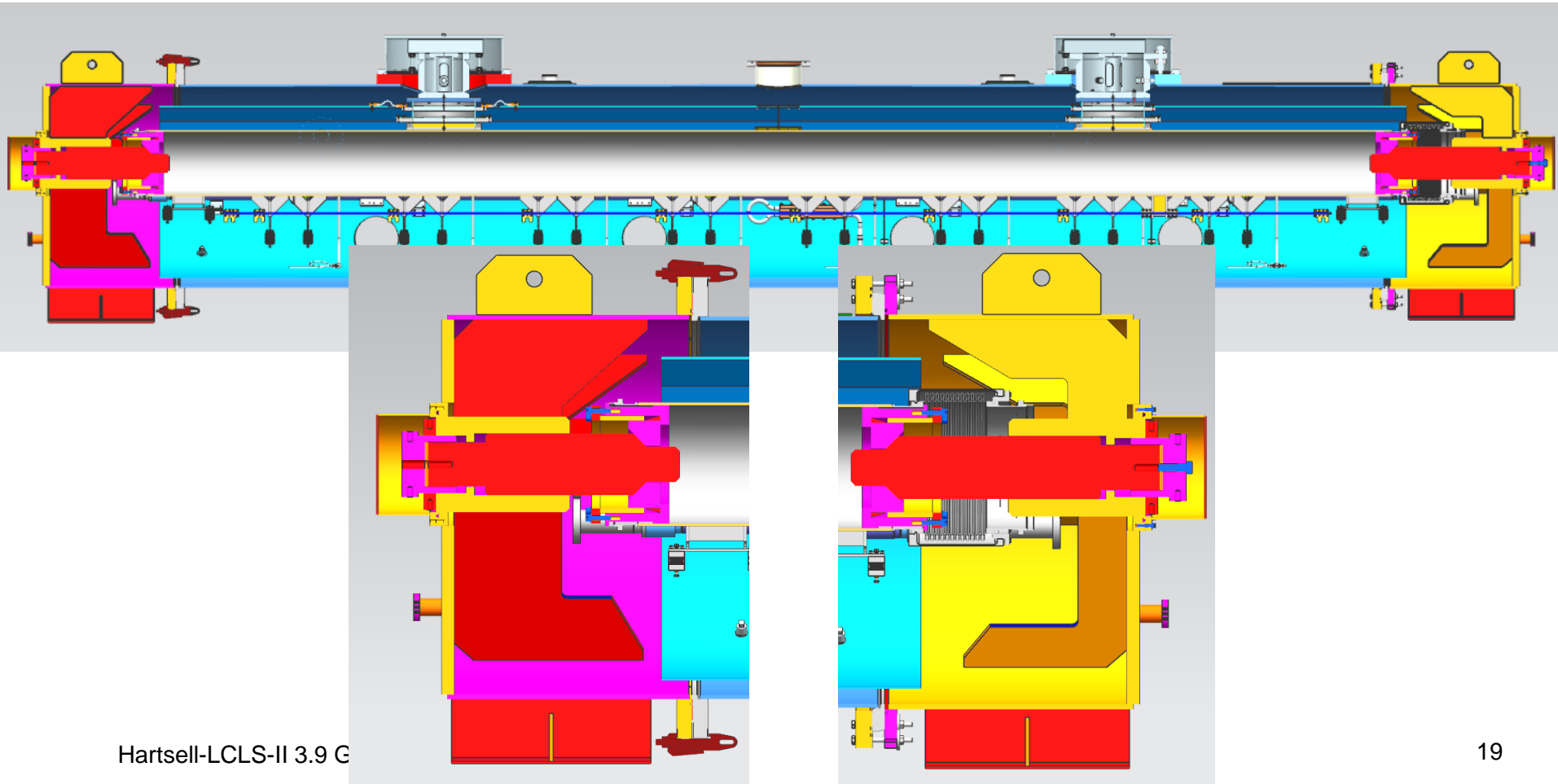

# Physical testing

---

- Use a dummy load to tune the isolation system.
  - Use concrete blocks on a support stand connected to the cryomodule mount points.
  - Match centers of gravity between dummy and 3.9 GHz CM.
  - Concrete stand will be engineered to safely restrain the concrete blocks.
- After isolation system is proven, simulations are complete and any mitigations implemented, move to testing with 3.9 GHz CM.

# Dummy load testing plan: Setup

- Commonly found concrete shielding blocks can be used to replicate weight and center of gravity.
- Support structure and safe block connections to each other and the transport fixture be engineered.

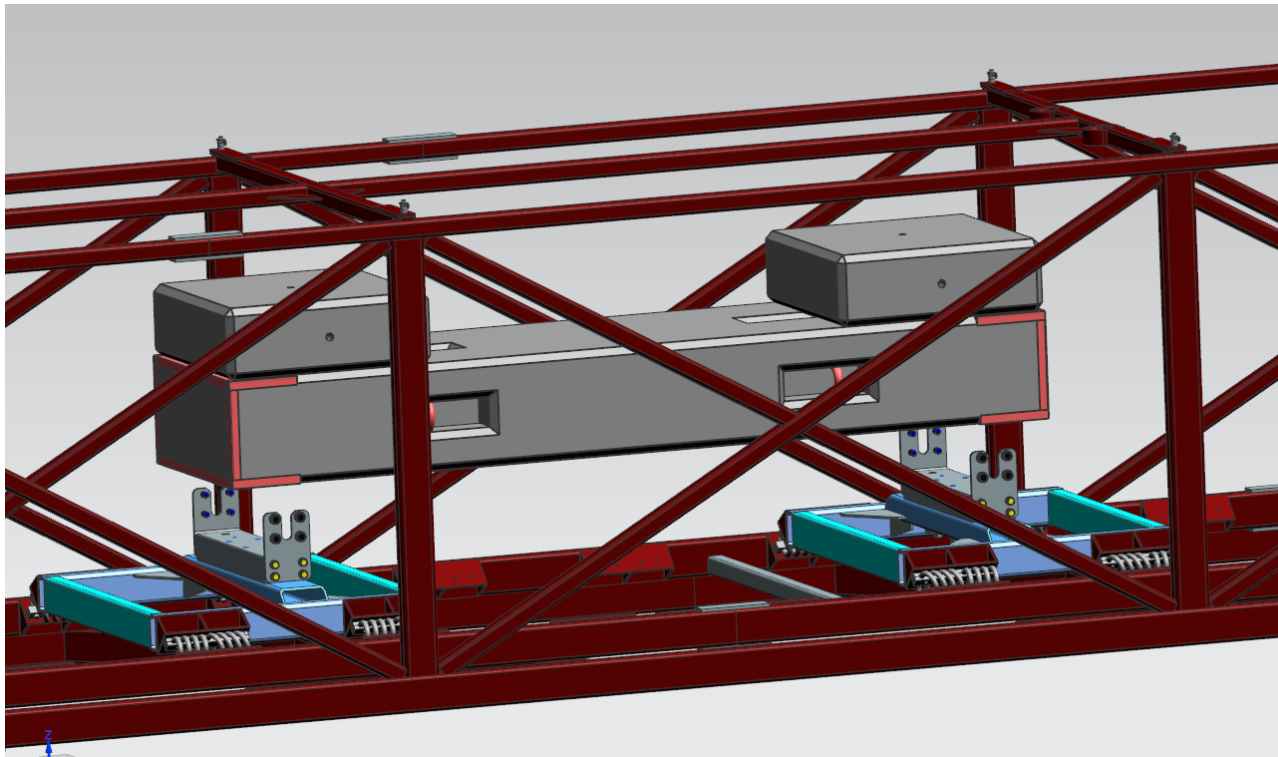

Component	Weight (lb)
J Block	8100
K Block	1400 x2
<b>Total</b>	<b>10,900</b>
<b>3.9 GHz CM + Caps (Est. from 3D model)</b>	<b>11,300</b>

# Dummy load testing plan: Route

- Low speed transports on-site to verify attenuation and proper fixation of blocks.
- “Short” test route out I-88 to Orchard Rd **x mi.**
- “Long” test route out to Morris, IL **x mi.**

Short Route

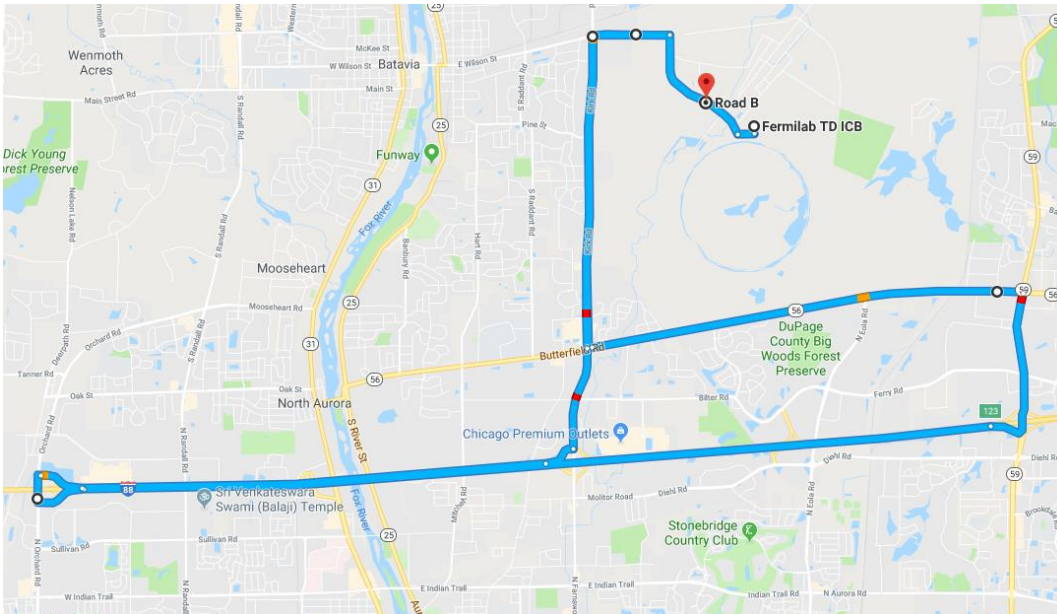

Long Route

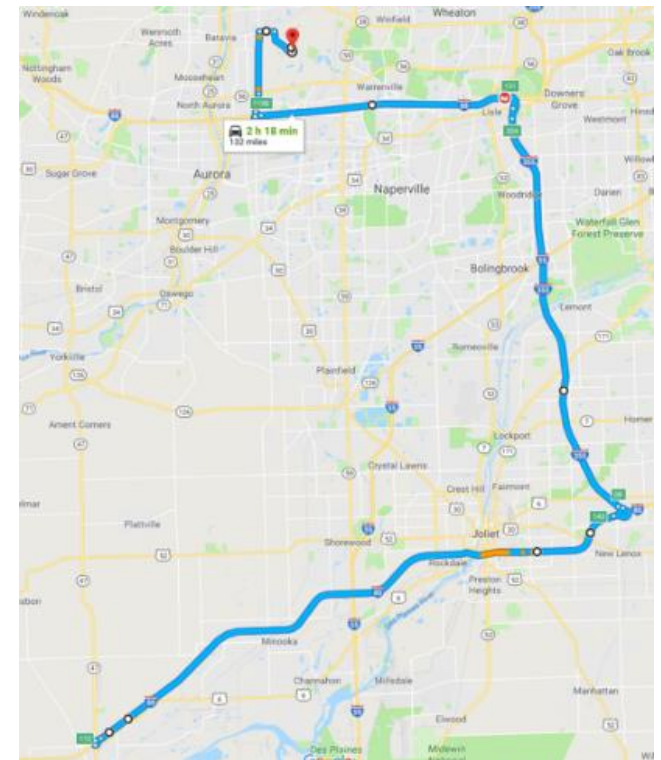

# Dummy load testing plan: Instrumentation

- Integrate lessons learned from 1.3 GHz dummy load testing into sensor placement:
  - Instrument the outer frame, inner frame, and concrete blocks using Slam Sticks proven from 1.3 GHz experience.
  - Instrument both fore and aft mounting points with the same setup.



# Dummy load testing plan:

## Criteria for success

---

- What do we define as a successful test?
  - Shocks under 1.5g (1.3 GHz spec) or set new limits via analysis of sensitive components.
  - Adequate dampening is shown from the frame to concrete transfer functions.
  - Resonant frequencies are below critical values determined through simulation and testing of sensitive components.



# Transport testing with 3.9 GHz CM

- Begin work with live CM once:
  - Simulations are complete
  - Any needed mitigations for sensitive components are in place
    - Physical testing for these components may be conducted
  - Dummy load testing is successful
  - Transport specifications that adequately protect sensitive components have been developed.
    - Based on calculations, testing, simulation.
    - Examples: maximum displacement, maximum shock, sustained loading.
  - **A successful review is conducted on live CM test plan and mitigations.**

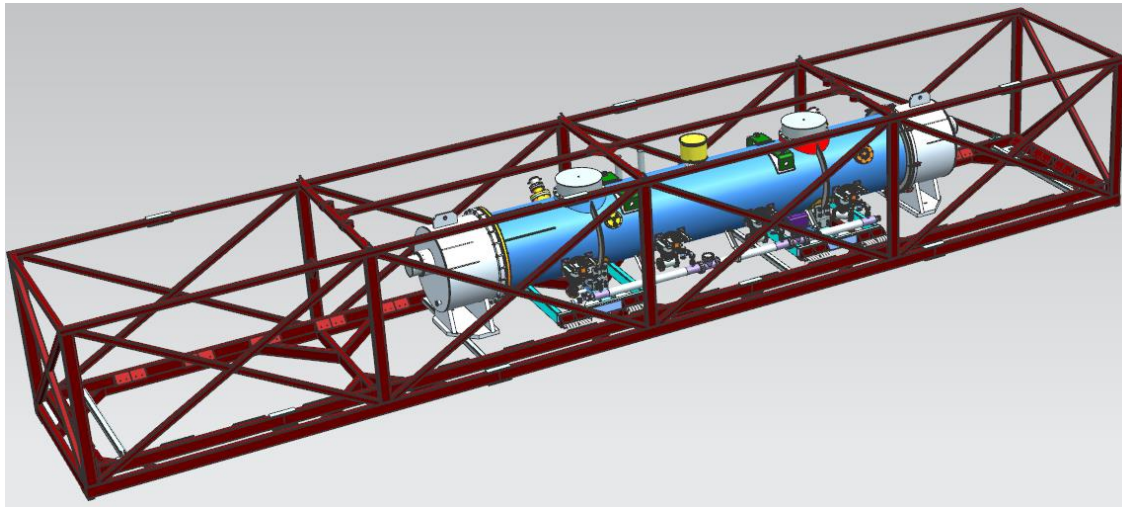

# Transport testing with 3.9 GHz CM

---

- Testing progresses through a similar progression as the dummy load:
  - Low speed, on-site testing
  - Short road tests
  - Longer road tests, building to a ~3hr test.
- Integrate lessons learned from each test into successive transport tests.

# Transport testing with 3.9 GHz CM: Lack of access ports

- Currently there are no access ports for post-assembly installation of instrumentation or mitigations for sensitive components. These ports are used extensively for 1.3 GHz shipping preparation.
- Sensors may be mounted before the cold mass is inserted into the cryostat for sensitive areas not able to be accessed.
  - Special versions of the slam stick without the integrated battery and remote buttons are available.
- Coupler bellows can be reached through instrumentation ports (below right).

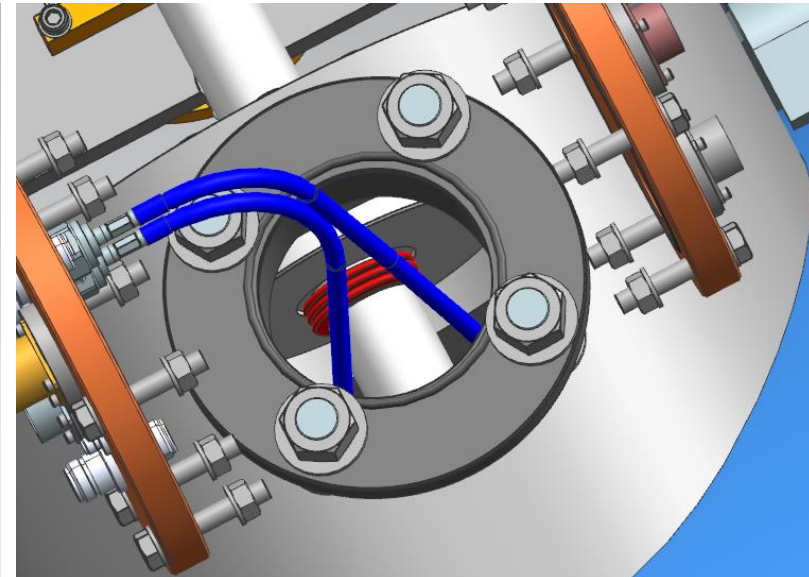
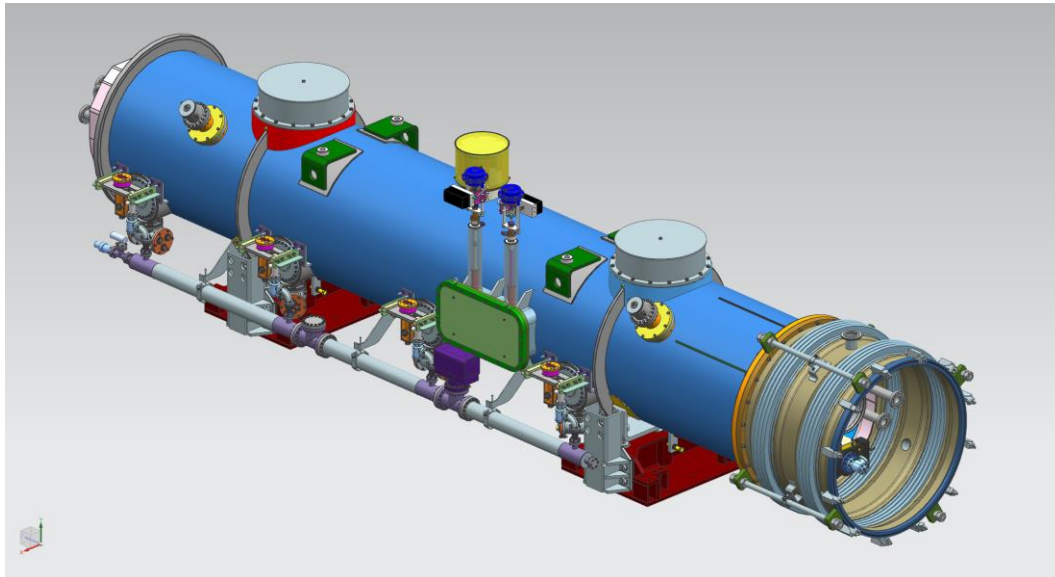

# Transport to SLAC

---

- Considerations:
  - All preparation work will have a written procedure, documented in traveler form with signoffs.
  - Prior to shipping preparation to SLAC, a shipping configuration drawing will be released.
  - Put PO in place with a transport company that understands the sensitivity of the transport.
  - Interface with SLAC receiving team to finalize an acceptance and handling plan.

# Summary

---

- An experienced team is working on this project.
- A plan is in place to provide a path to safely ship LCLS-II 3.9 GHz cryomodules to SLAC.
  - Start with reviews and simulations of the design to identify sensitive components of the CM.
  - Develop mitigations for sensitive components if necessary.
  - In parallel, develop the isolation system and test with a dummy load.
  - Hold a review of the 3.9 GHz shipping plan before testing a live cryomodule.
  - Slowly build up mileage testing with a live CM.