



LCLS-II

# LCLS-II 3.9GHz Cryomodules Assembly at Fermilab

Tug Arkan / Chuck Grimm

LCLS-II 3.9 GHz CM Delta Final Design Review

January 29-30, 2019

# Outline

- Production Strategy
- Fermilab Cryomodule Assembly Facility (CAF) infrastructure
- Detailed CM Assembly Workflow at CAF
- Travelers and Part kits
- Summary

# Planned LCLS-II Production CMs Workflow at Fermilab

---

1. Receive dressed, ready to be tested in VTS (vertical test stand) cavities from the vendors (Beamline under vacuum)
2. Incoming Inspection at IB4
3. Test cavities in VTS at IB1
4. Qualified Cavities go to CAF-MP9 cleanroom WS1. Non qualified cavities will be re-processed (HPR, light EP etc.) and re-tested.
5. 8 qualified cavities, Cold end FPCs, BPM, Gate Valves, Interconnecting Bellows/Spool: Cavity String Assembly at CAF-MP9 Cleanroom (WS1)
6. Cold Mass Assembly at CAF-MP9 (WS2)
7. Cold Mass Assembly at CAF-ICB (WS3 & WS4)
8. Final Assembly and QC checks (WS5) and prep for transport to CMTS at CAF-ICB (WS6)
9. Cryomodule Test at CMTS
10. Transport the module back to CAF-ICB
11. Prepare and Ship Module to SLAC (WS6)

# CAF-MP9 during LCLS-II Production

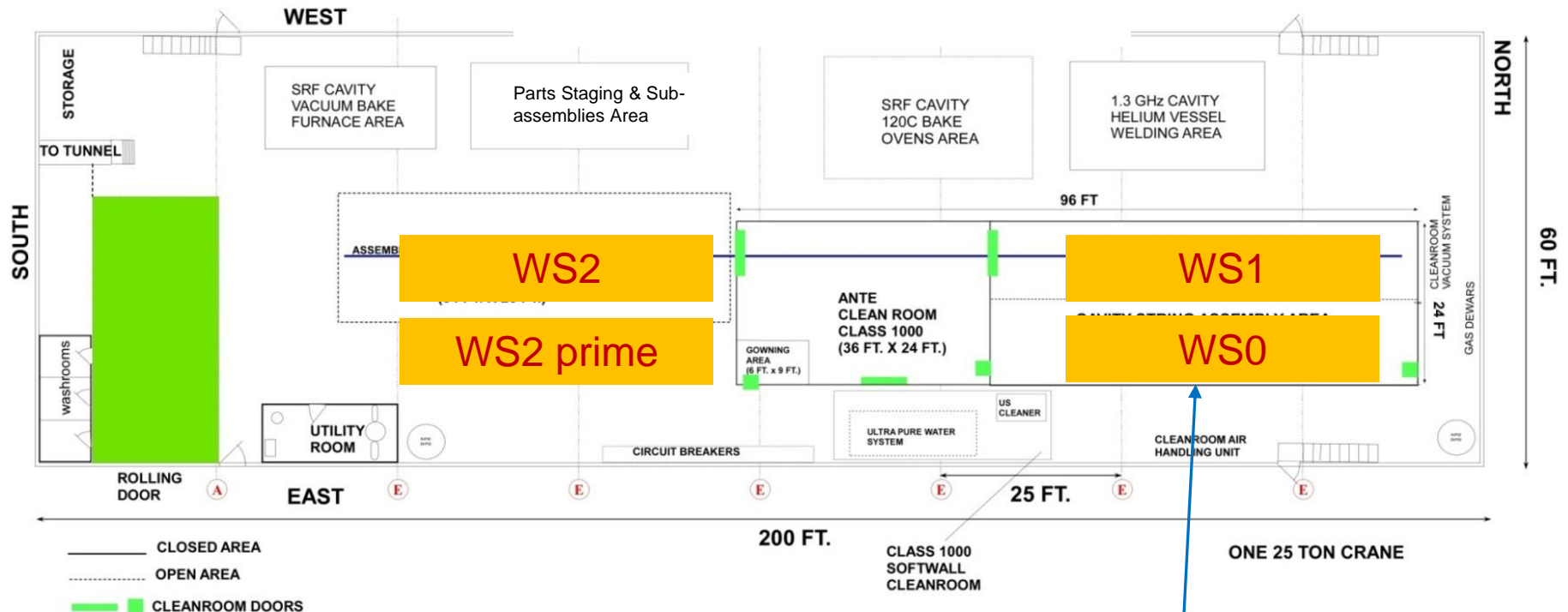

*WS0 will not be used during 3.9GHz CM cleanroom assembly, cold end FPC will be installed at WS1*

# CAF-ICB during LCLS-II Production

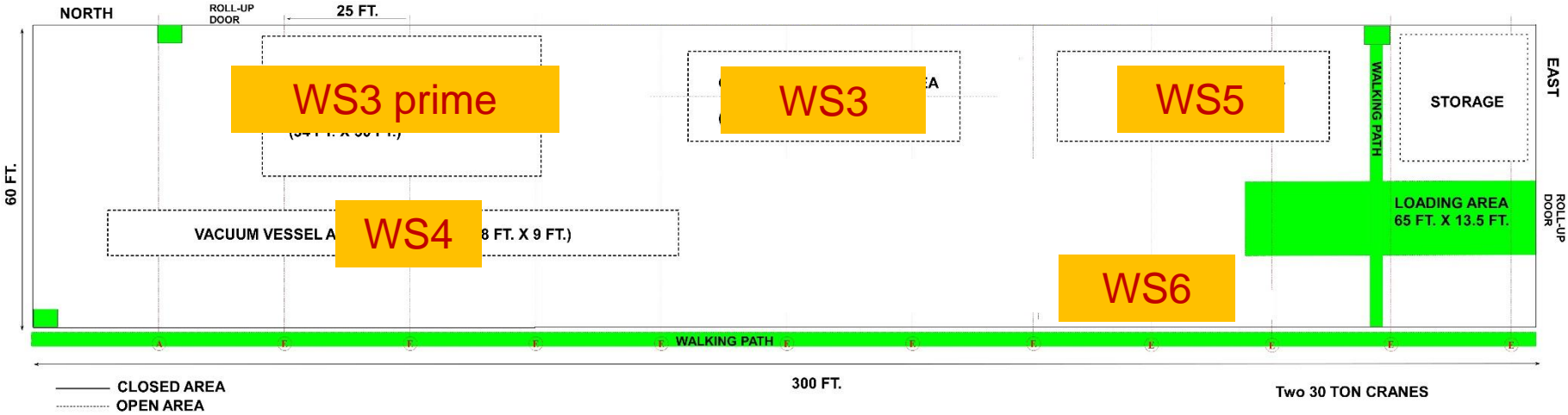

# Supply Chain

- Dressed cavities (RI) delivered ready to be tested
- Fundamental power couplers (CPI) delivered ready to be assembled at WS1 and WS5
- Gate valves (VAT) cleaned to Class 100 standard at the vendor
- BPM cleaned to Class 10 standard at DESY
- BPM electrical feedthroughs (Solcera)
- Copper plated beamline components (Ameriflex, copper plated at SLAC)
- Cavity String Assembly Hardware (JT industries) and Seals (Wepek)
- Cold Mass Upper assembly (WXCX, China)
- Cold Mass peripherals from various U.S. vendors
- Instrumentation (U.S and International vendors)
- Vacuum Vessel (WXCX, China)
- Vacuum vessel peripherals from various U.S. vendors

Full or batch delivery ➡ FNAL Supply Chain Manager working with SOTRs & TD QMD for qualified parts storage in TD inventory system ➡ Parts are kitted (MBOM) & delivered to work stations ➡ Sort, magnetic hygiene QC, clean and use

# MP9 Clean Room

## Cavity String Assembly Clean Room (WS0 & WS1)

A ~250 square-meter clean room:

- Class 1000 (ISO6) ante cleanroom area
- Class 100 (ISO5) sluice area
- Class 10 (ISO4) assembly area
- Class 100 (ISO5) staging/storage area

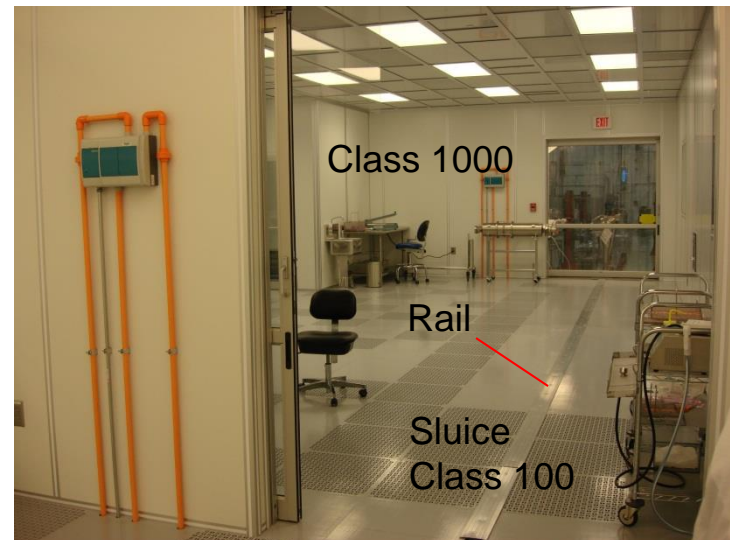
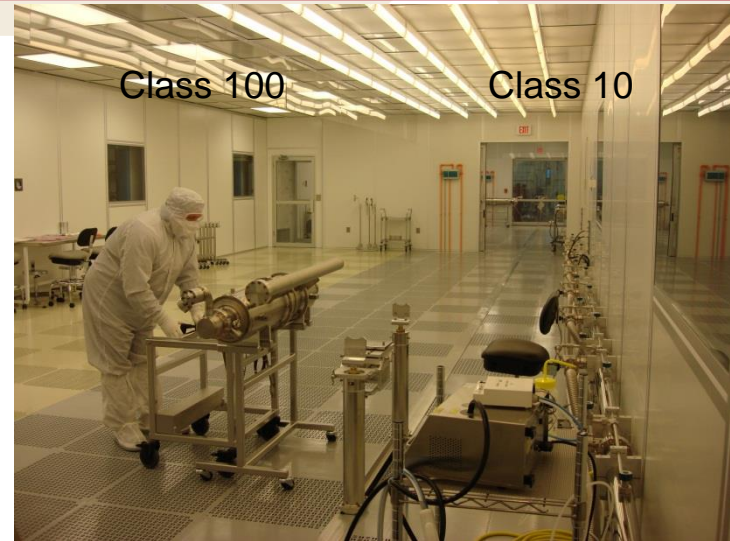

# Cleanroom Infrastructure

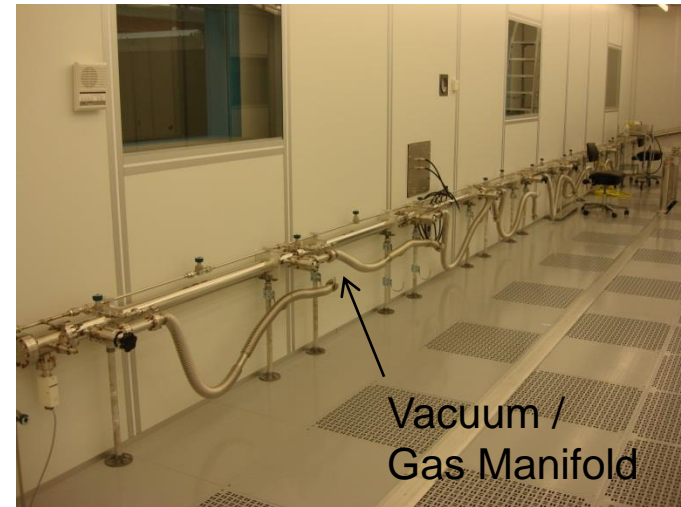

Vacuum /  
Gas Manifold



8 stations for pumping,  
purging and backfilling

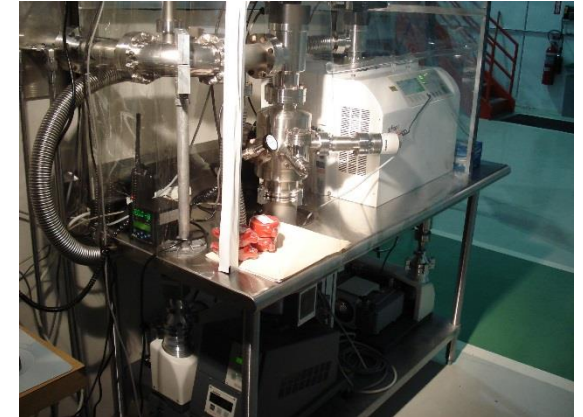

Particle Free UHV Pumps  
System



Class 1000 softwall cleanroom for dry  
cleaning before entry to ante  
cleanroom



Cavity Support Fix Rail  
System



Boiled-off LN2 gas dewars  
and gas delivery panels



# Dressed cavities that will be delivered to CAF-MP9 cleanroom

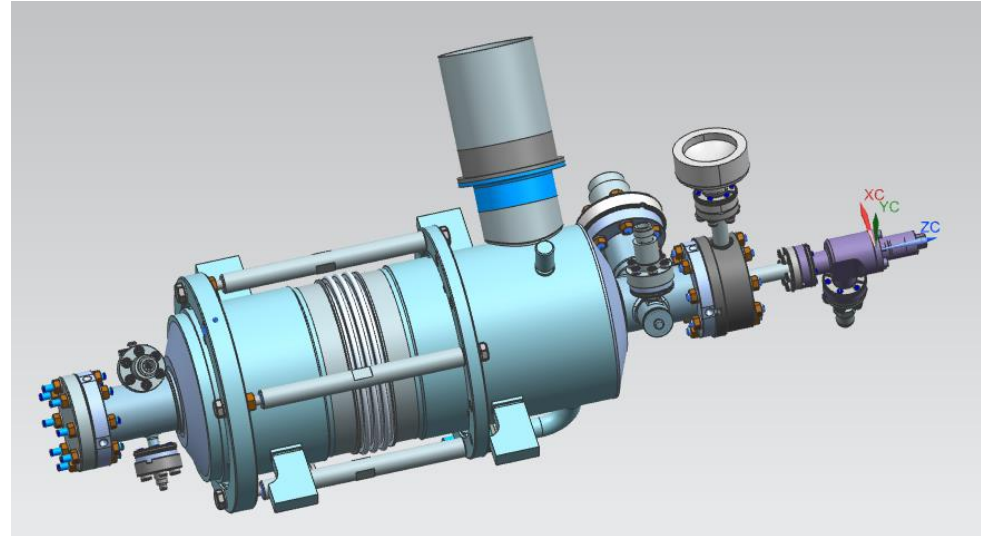
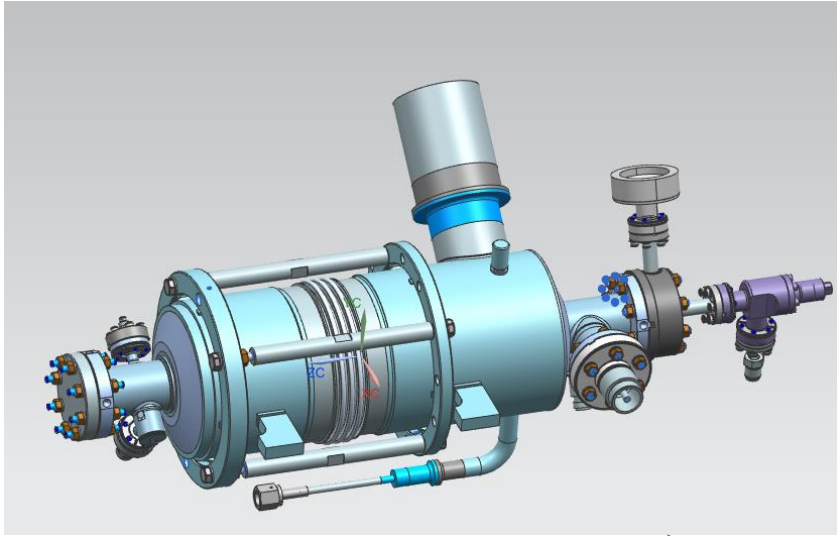

Dressed Cavity Type A

Dressed Cavity Type B

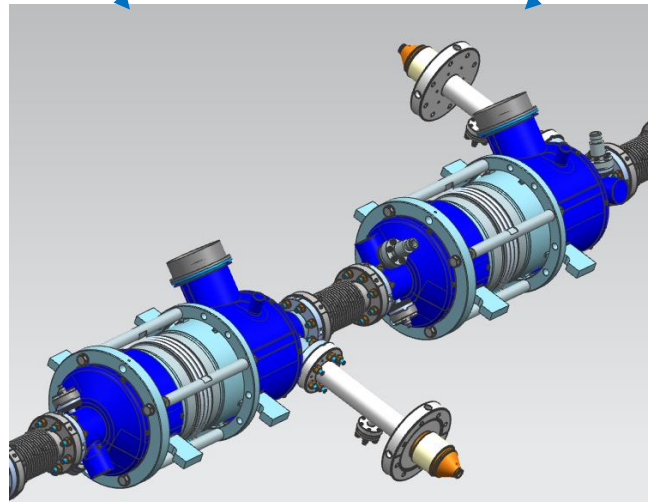

# String Assembly Workflow at CAF-MP9 Cleanroom

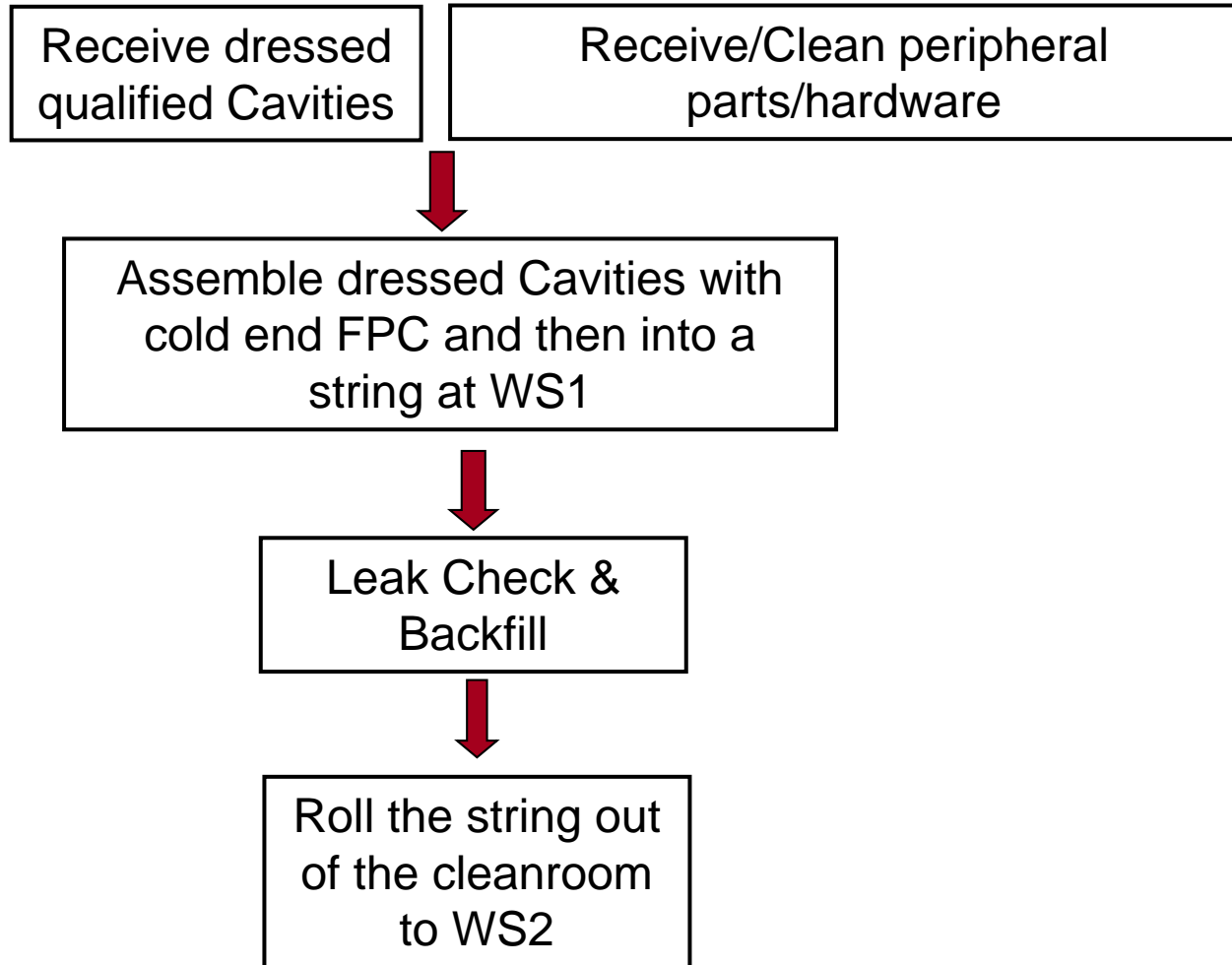

# Parts / Fixtures / Hardware

## Entrance to Cleanroom Preparation

*Magnetic Hygiene Quality Control for every part, hardware, fixtures, tools that will be used in the cleanroom for assembly prior cleaning: Even though the cavities are not nitrogen doped, the same scrutiny will be followed for magnetic hygiene to achieve the highest Q0*

### Assembly hardware:

- Wash in the ultrasonic bath
- Dry under ISO 4 hood
- Move into the ISO 6 ante clean room
- Blow clean with ionized nitrogen while monitoring the particle count in the sluice area (ISO 4)
- Transport into the ISO 4 assembly area

Electro-polished, rolled thread 316L stainless steel studs; silicon bronze nuts



ISO 6  
softwall  
cleanroom

ISO 4 Hood

US  
cleaners



# Cleanroom Audit Recommendation (S. Berry)

Recommendations	Description	Priority	Schedule Impact	Cost Impact
1 Implemented	Guarantee the inside cleanliness for inter-cavity bellow, spool piece, coupler...	High	No	No
2 Not implemented	Increase the purging rate to 3L/min instead of 1L/min	High	No	No
3 Implemented	Install the purge line closer to the cavity	High	5 days	120 Hours
4 Not implemented	Revise the Bellows Assembly Procedure			
5 Implemented	Pump slowly 3 L/min (50 mbarL/s) and vent slowly	High	No	No
6 will be implemented for 3.9GHz	Move WS0 to WS1 location	Medium	5 days for every string assembly	No
7 will be implemented for 3.9GHz	Reduce valve opening	Medium	-5 days	No
8 Implemented	WS5 Improvement	Medium	No	No
9 Implemented	CMTF Improvement	Medium	No	No
10 Implemented	Gowning Area Improvement	Medium	No	No
11 Implemented	Miscellaneous Improvement	Medium	No	No

# Cold End Coupler Assembly (WS1)

1. Verify torque and tighten as needed all the fasteners for the cavity beamline(under vacuum) as received (lesson learned from 1.3GHz)
2. Assemble & leak check new pump/backfill/purge flex hose with tee to the cavity (Recommendation 3 needs to be implemented for WS1)
3. Open cavity right angle valve (RAV)
4. Record as received vacuum levels
5. Leak check, RGA
6. Backfill (vent) the cavity
7. Remove a cold end coupler from the storage manifold
8. Assemble cold end coupler to the cavity using particle free flange assembly (PFFA) procedures with nitrogen purge of 1 liter / minute (Recommendation 2 is to increase to 3 liter / minute, not implemented based on the actual purge rates measured and recent good results of tested 1.3GHz CMs at CMTS)
9. ~~Pump down, leak check, RGA, Backfill~~ (Recommendation 3)
10. Leave cavity RAV open (Recommendation 7 will be implemented)
11. Leave the beamline vented with nitrogen until the cavity is ready be interconnected to the string (Recommendation 3)



# String Assembly-I (WS1)

- Rotational alignment of cavities
- Gate Valve (GV1) to Cavity #1  
Assembly:
  - Check the particle free cleanliness of the GV and clean as needed
  - Sub-assembly of the GV peripherals
  - Installation to the support post and vacuum hose assembly
  - Alignment to the cavity beam line flange
  - Assemble the gate valve to the cavity

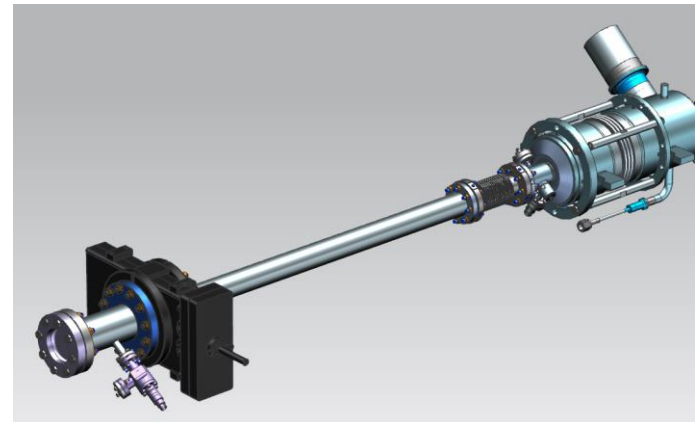

# String Assembly-II (WS1)

Cavity to Cavity Assembly with the interconnect bellows:

- Assemble flex hose to the cavity RAV
- Pump down, leak check the hose connection to the RAV, backfill
- Align the interconnect bellows to the cavity field probe end beampipe flange
- Assemble with PFFA
- Align the bellows to the cavity coupler end beampipe flange
- Assemble with PFFA

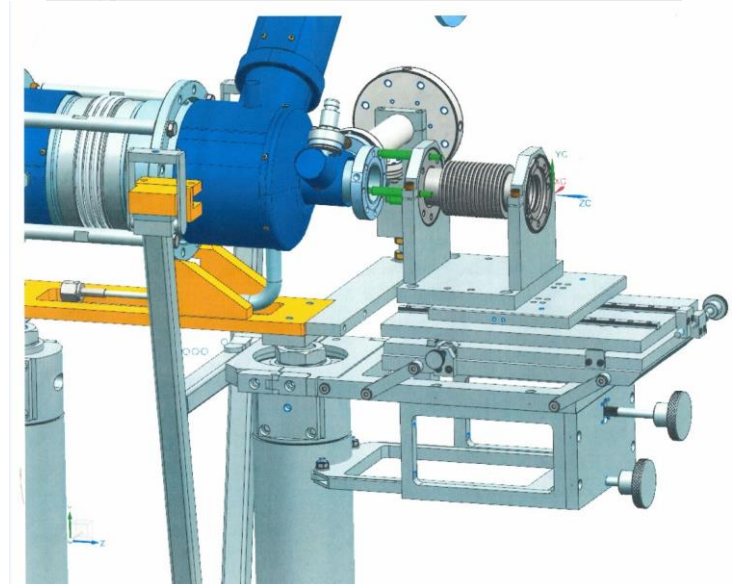

# String Assembly-III (WS1)

- BPM+GV2 assembly and leak check
- BPM/GV2 subassembly to the 8 cavity string
- Pump down fully assembled cavity string, bag the bellows, leak check. Backfill
- Roll out of the cleanroom to WS2

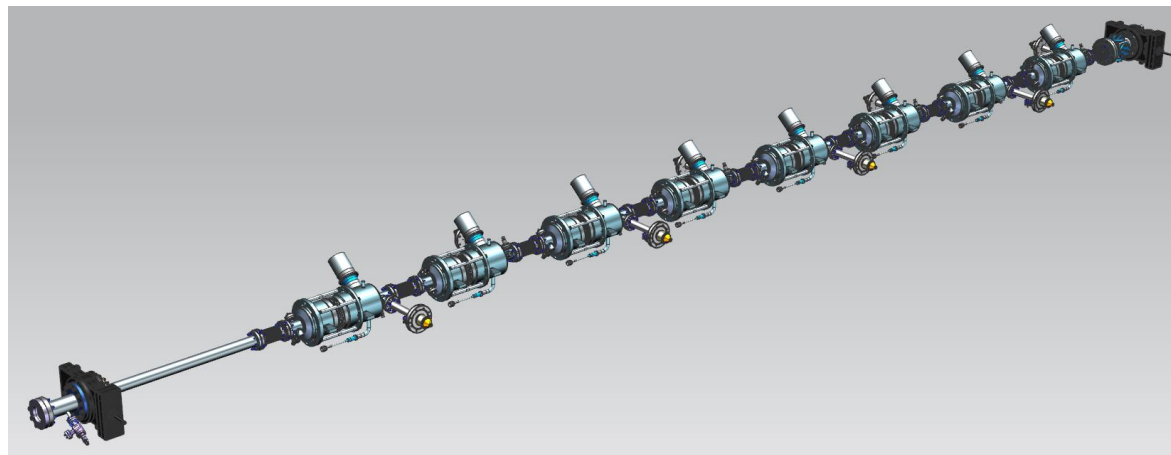



# Lessons Learned that will be applied to 3.9GHz CM assembly in the cleanroom

- Cavity fasteners torque check & adjust post vertical test before starting the string assembly in the MP9 cleanroom
- Al/Mg seals hardness certified by the vendor
- Delrin holders for NW40 size (and smaller) Al/Mg seals: NW78 size seals can be slightly deformed and will not fall once placed in the flange during assembly, small size seals need holders.
- BPM electrical feedthroughs titanium grade 5 fasteners
- Bellows between Cav#1 and upstream end gate valve (microphonics optimization)
- Gate valves and right angle valves leak check to verify that sealing through before assembling these valves to the cavity string
- Reduce torque for M6 size hardware from 20 N-m to 13.5 N-m
- Final torqueing and verification of the string assembly fasteners before string rolls out to WS2

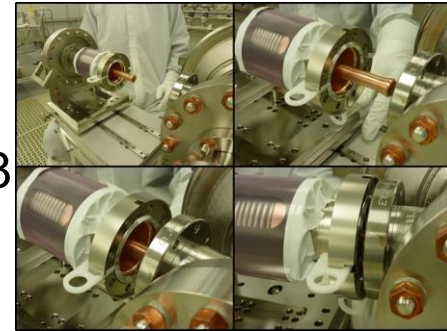

# Cold Mass Assembly at WS2

After Roll-Out at WS2



Dressed Cavity Ordered Without Tee

# 2-Phase Line Welding at WS2

Same welding configuration and parameters  
Tee will be added as part of the procedure

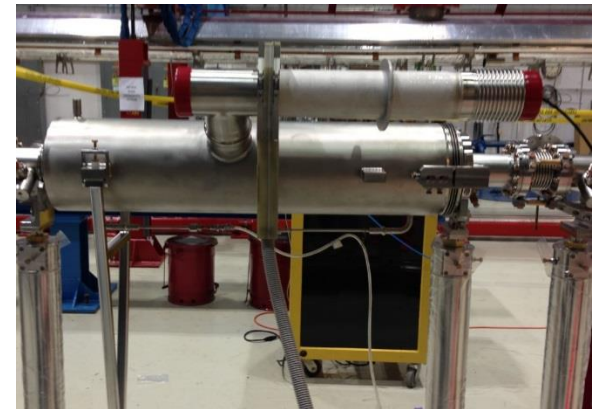
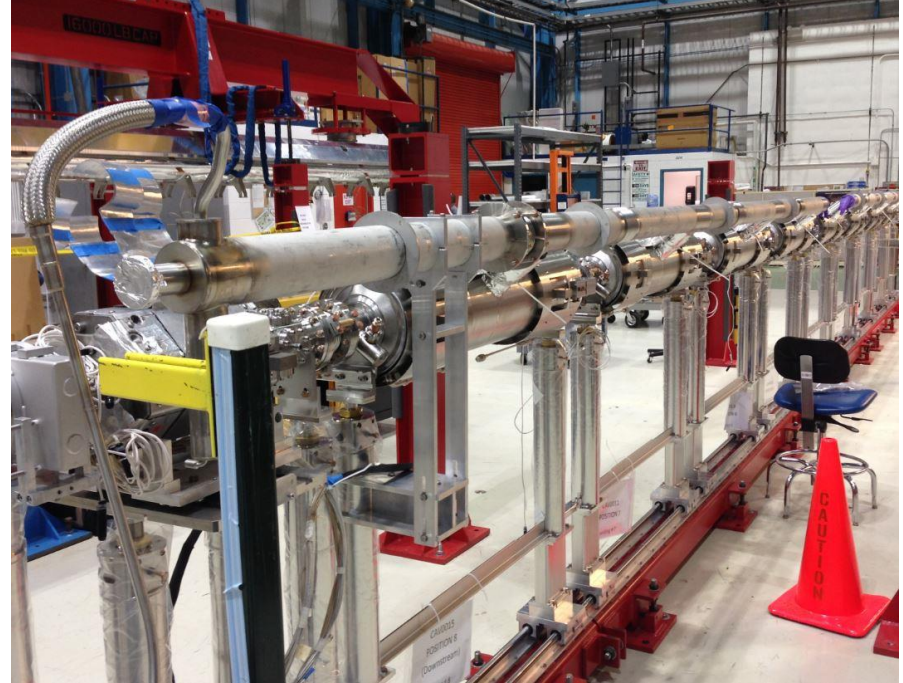
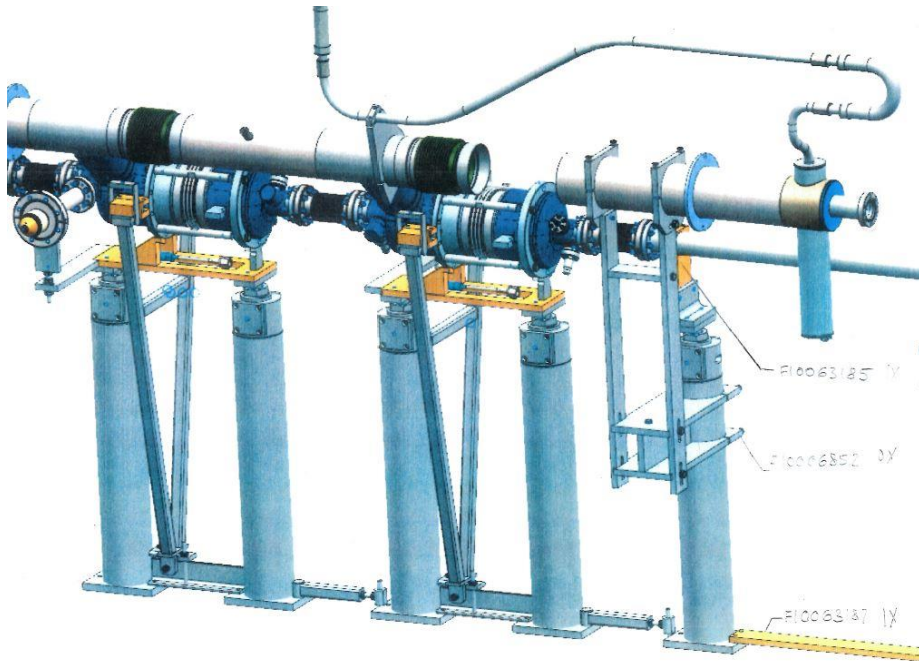

*Tack weld then majority of the welds are done with automatic orbital welding machine. Some welds are done manually. All the welders are qualified and certified to provide code compliant welds*

# Tank Heaters at WS2

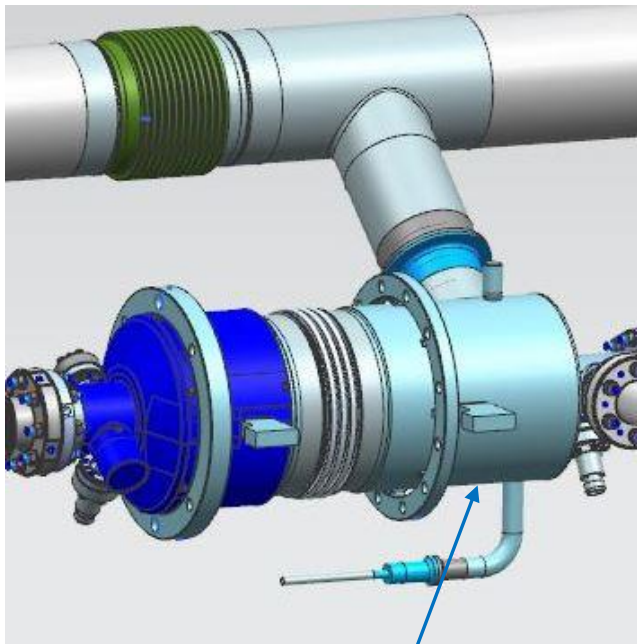

Heaters will be installed in this location



Along with Kapton tape and Stycast, Ti shim material will keep heaters securely fastened to He tanks like 1.3GHz 20

# Magnetic Shielding Assembly at WS2

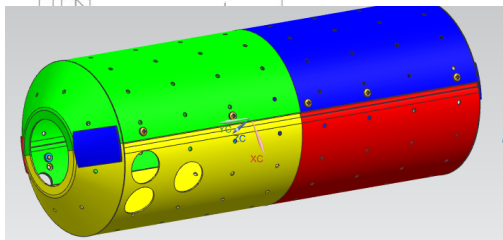
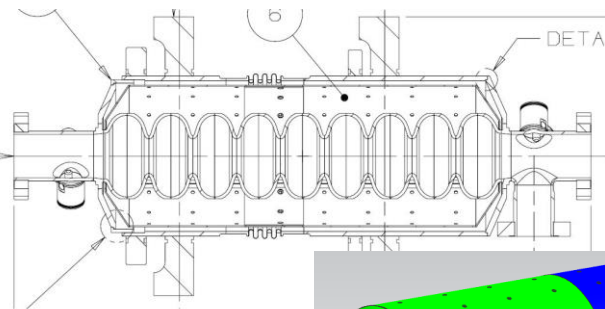
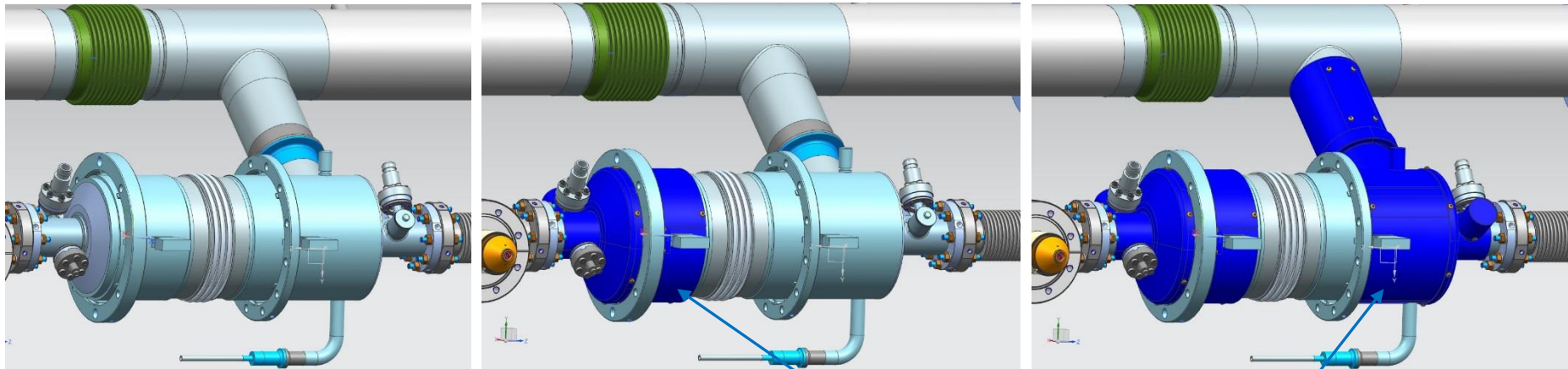

Shields installed on the upstream and downstream ends and up the chimney – not on the outside center section

Internal He vessel shield will cover length of cavity end-to-end

# Blade Tuner Installation at WS2

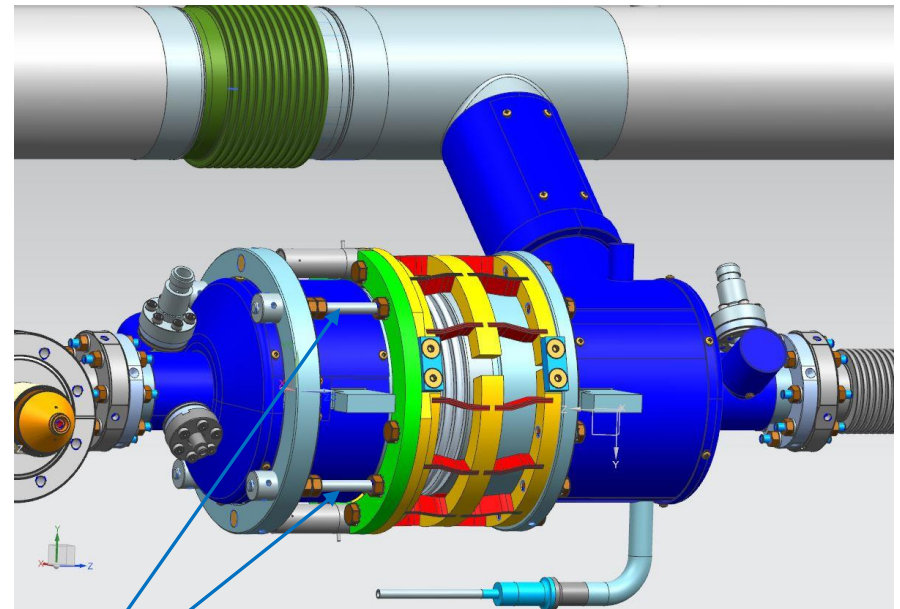
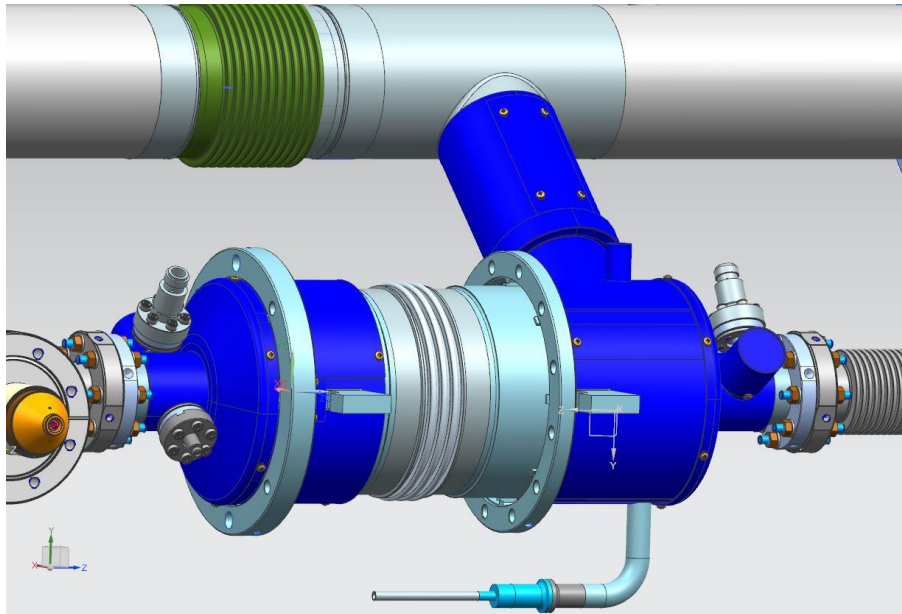

Safety rods

Bladetuner and piezos installed at WS2 (*1.3 GHz lever tuner was installed at WS3*)

Bladetuner has safety rods for safe transport

# Upper Cold Mass (UCM) to String Assembly at WS2

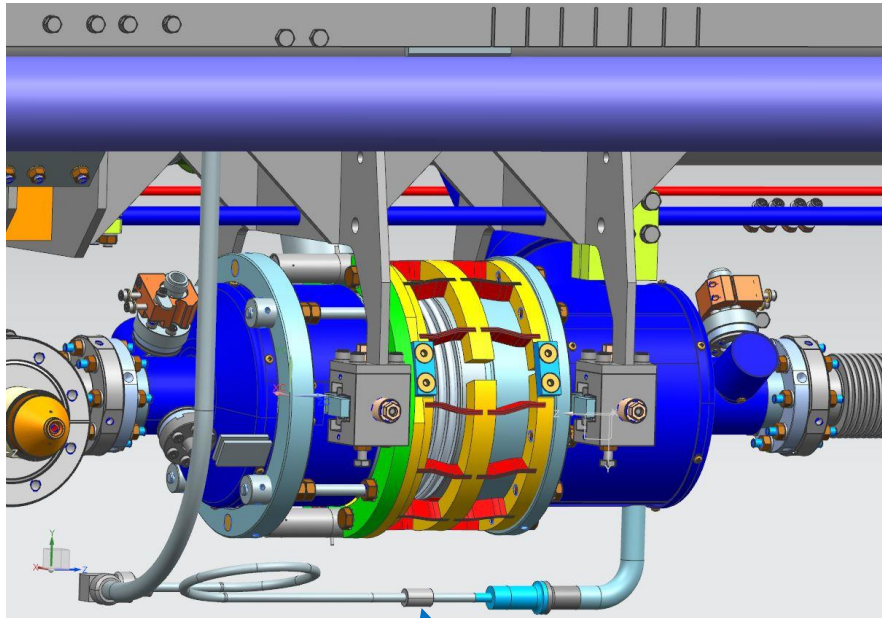

Warm-up/Cool-down welding same as 1.3 GHz

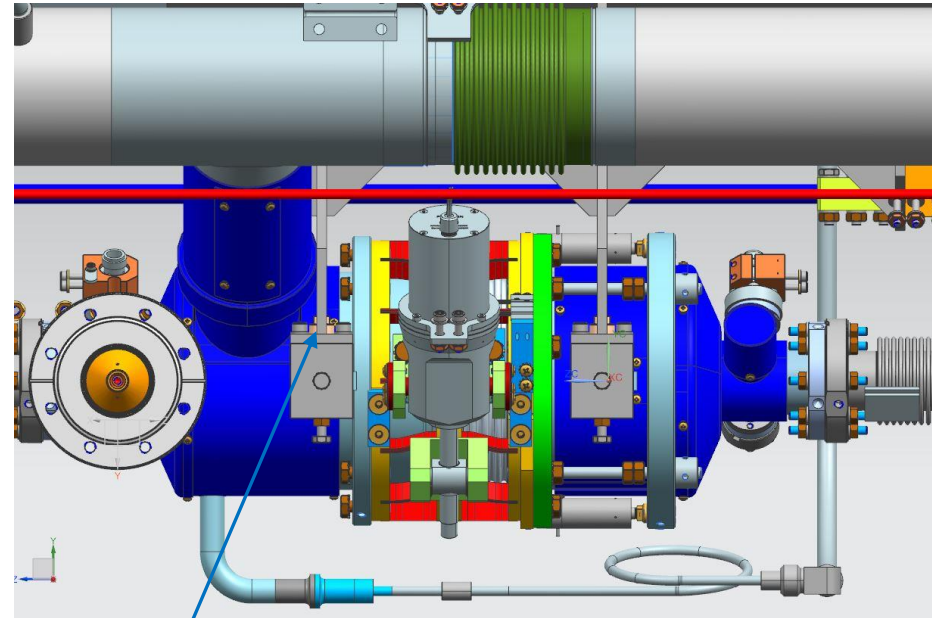

Due to a slight interference issue with the bearing block leg and 2-phase chimney, the cavity string will need to be rolled upstream slightly on the lollipop stands than back downstream after clearing the chimney

# Remaining tasks at WS2 before transport to WS3

---

- Leveling of the cold mass
- Z alignment of the cavity string
- Weld 2-phase pipe invar rod radial clamps (2-phase pipe end are closed)
- Leak check 2-phase circuit (after blade-tuner is setup to specified configuration)
- Prep for transport to WS3



# Lessons Learned that will be applied to 3.9GHz CM assembly at WS2

---

- Optimized orbital welding programs for 316L stainless steel welding (to compensate wall thickness variations, sulfur content etc.)
- Welding of the warm/up-cool down capillaries, tee from 2-phase pipe to HGRP and 2-phase pipe invar rods radial clamps after Z longitudinal of the cavities are done.
- Shimming optimizations to ensure that the liquid level probes housing at the ends of the 2-phase pipe are welded and assembled leveled and free to allow HGRP contraction and expansion
- Invar rod reinforced clamps for Cav#1 and Cav#8 where the reacted vacuum forces are highest
- Leveling and alignment of the upper cold mass to the cavity string with the help of alignment group using laser tracker. Plumb bobs and mechanical means for alignment do not work well for CW CMs where the 2-phase pipe is connected to the HGRP
- Increased attention for fasteners locking mechanism (at least two such as torqueing, lock washers, Belleville washers, Loctite etc. to prevent loosening during operation and transports
- White gloves handling of the magnetic shielding parts

# Transport to WS3 at CAF-ICB

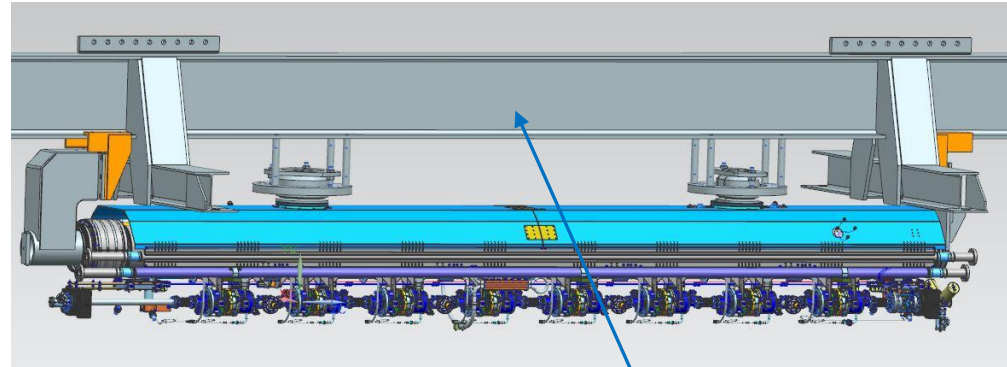

Modifications to red fixture allows to use for 3.9 GHz upper coldmass move (fixture is already modified, engineering note is updated, upper cold mass#1 incoming QC done using this modified fixture)

1.3 GHz upper coldmass fixture

Same transport fixture will be used



# Cavity String Alignment at WS3

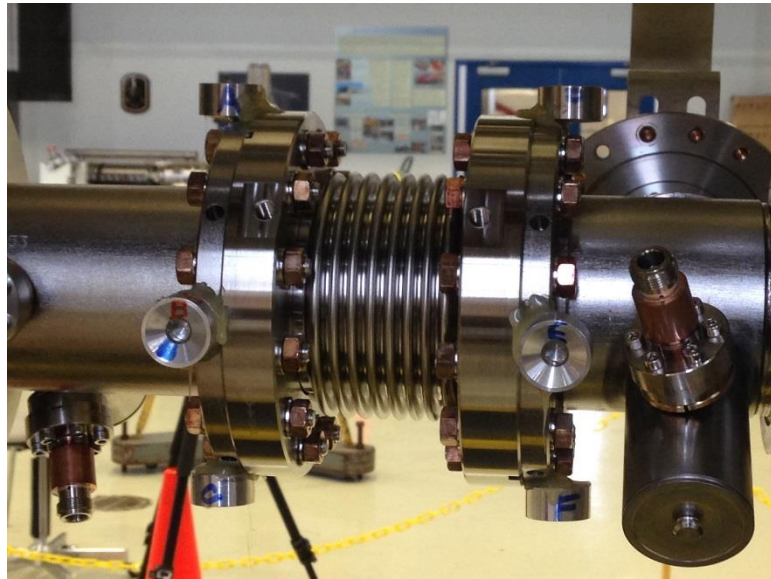

Fiducials Glued on Beam Flanges



Laser Tracker

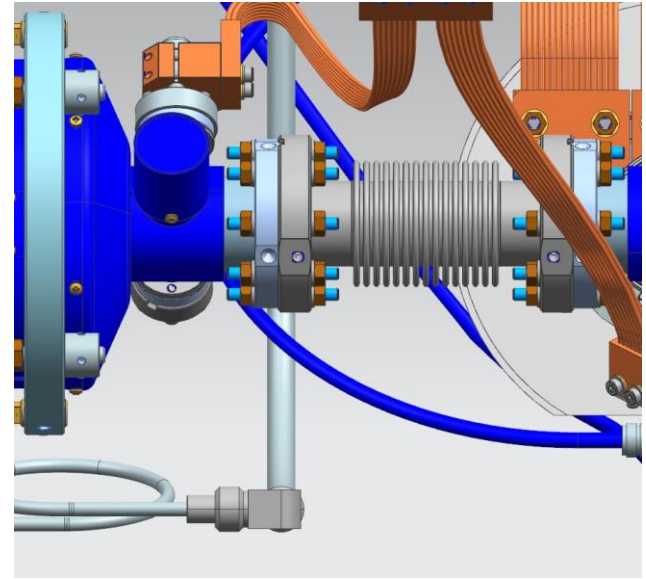

Verify Z alignment then  
complete X-Y alignment

# Cavity String Alignment at WS3

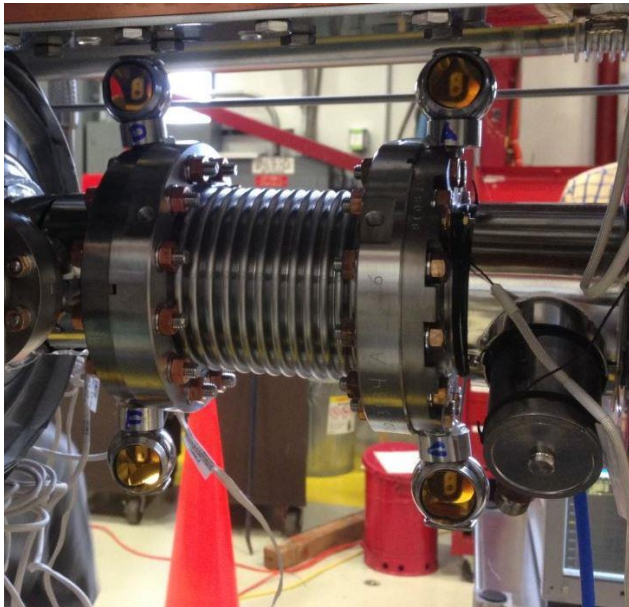

Larger diameter prisms are more desirable

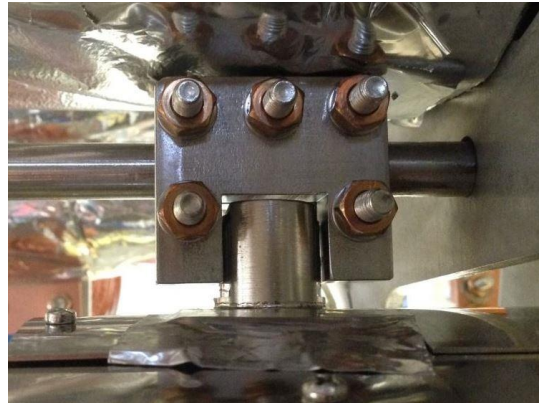

Cavity clamp  
to invar rod

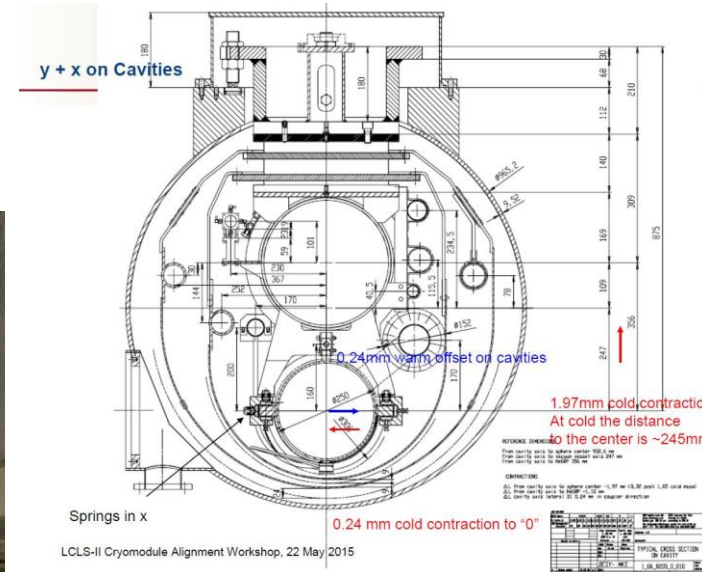

"Z" tolerance +/- 0.5 mm  
Relative to FPC spacing

"X" tolerance +/- 0.150 mm

"Y" tolerance +/- 0.150 mm

Relative to electrical centerline  
of cavity

# Thermal Straps and Cables Installation at WS3

Follow all the requirements as it was done for 1.3GHz CMs: indium, torqueing fasteners with intervals sequence, additional visual and manual verifications

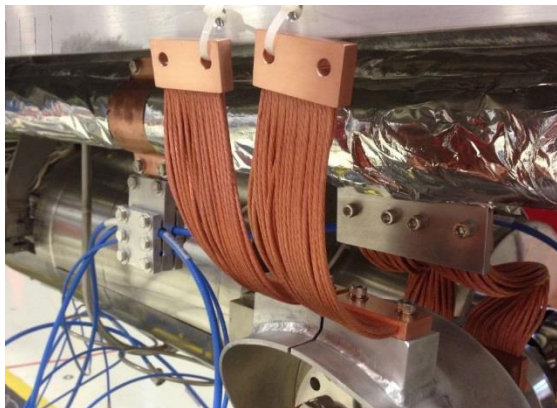
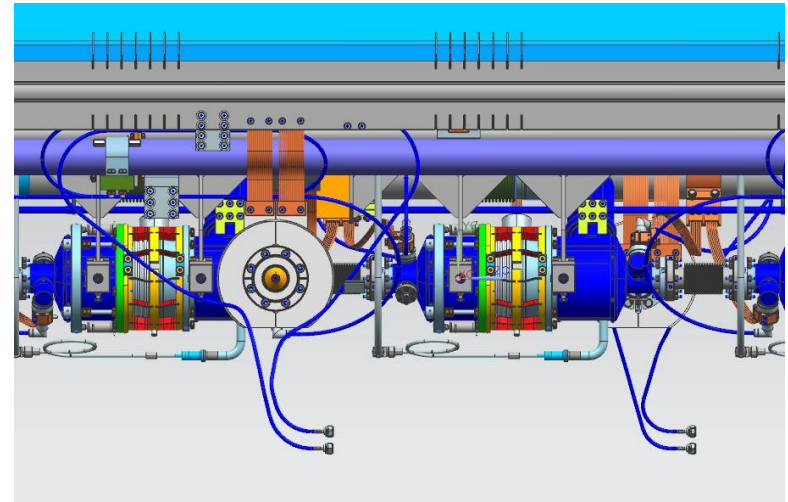
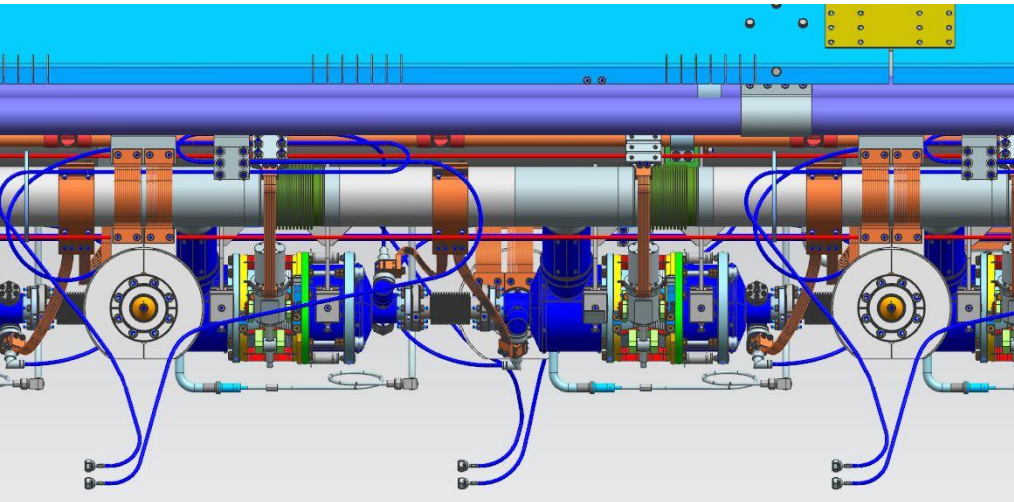

# QC checks before proceeding to weld lower shields

---

- Full electrical check
- Full tuner system check
- Full magnet and current leads check
- Verify fasteners torque
- HOM notch frequency tuning and final RF checks (*ensure that this is the last task done before proceeding to install lower heat shields*)

# Lower Thermal Shields at WS3

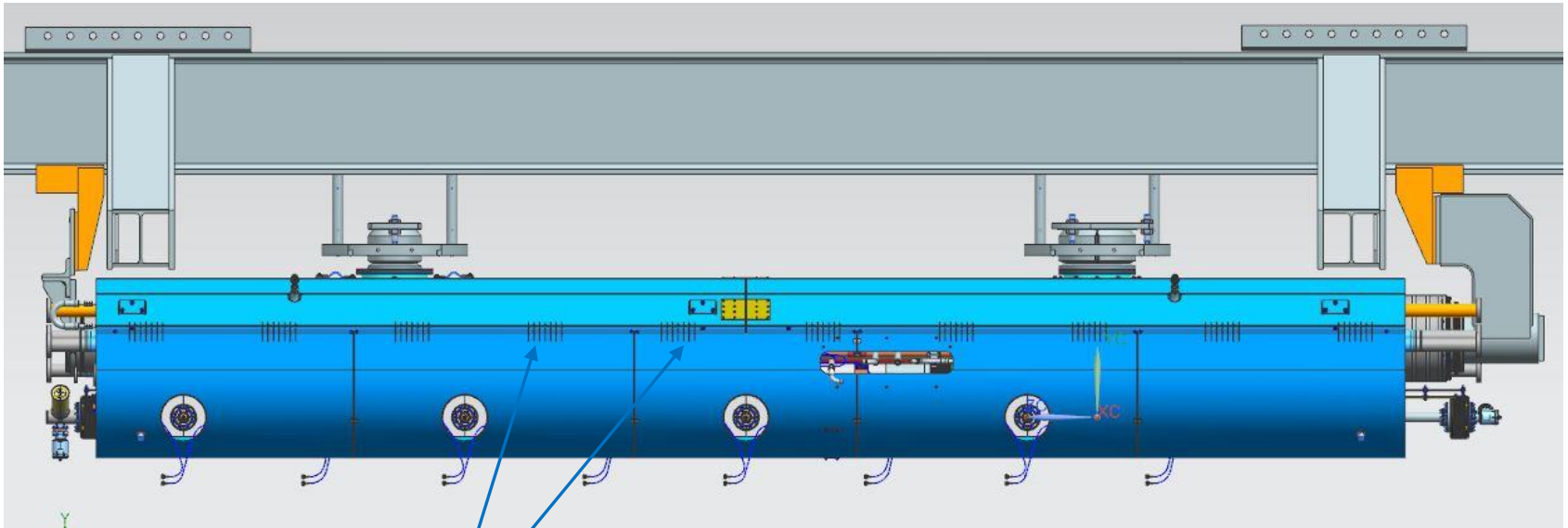

Finger Welds

Same setup as 1.3 GHz except  
coupler ports on opposite sides

# Lessons Learned that will be applied to 3.9GHz CM assembly at WS3

---

- Increased attention for fasteners locking mechanism (at least two such as torqueing, lock washers, Belleville washers, Loctite etc. to prevent loosening during operation and transports)
- Additional scrutiny for thermal intercepts assembly hardware
- RF group support during the RF cables 5K and 50K thermal intercepts installation
- HOM notch frequency tuning as the last step before installation of the lower heat shields
- Install lower heat shields one by one and inspect to ensure that shield does not have any contact with internals of the cavity string including RF cables. Weld lower heat shields and inspect again for any contact
- Ensure that upper cold invar rod hole locations are measured during incoming QC. This will ensure that we can complete the vertical alignment of the cavities without any interference between invar rod and cavity helium vessel titanium pin



# MLI and Vacuum Vessel Integration at WS4



Setup on cantilever fixture same as 1.3 GHz



MLI blankets

Coldmass integration to vacuum vessel same as 1.3 GHz

Cantilever fixtures does not need any modification to support 3.9GHz CM cold mass and vacuum vessel

# Final Cavity Alignment at WS4

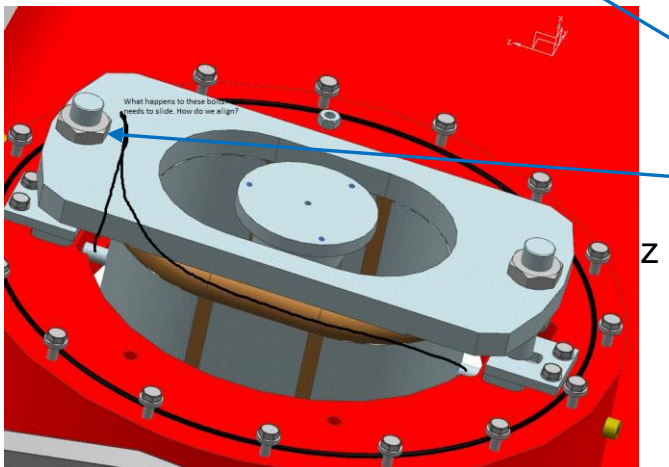
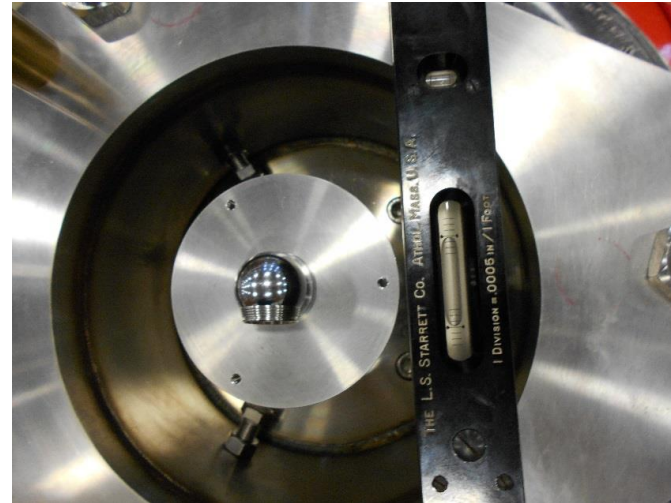
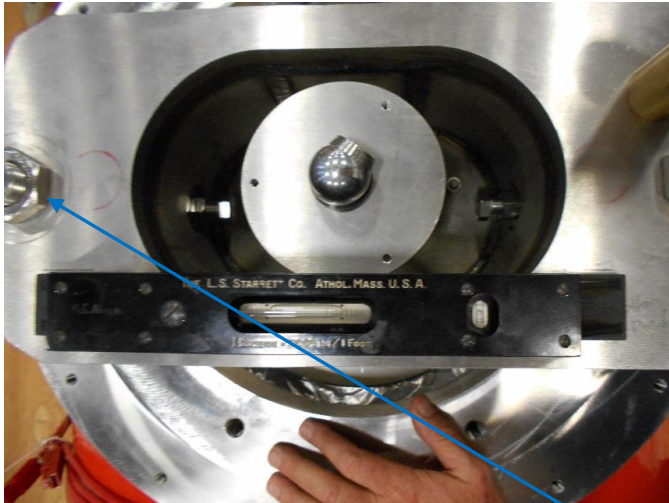

Once the vacuum vessel and coldmass is leveled, the roll is taken out by adjusting the support nuts

# Final Cavity Alignment at WS4

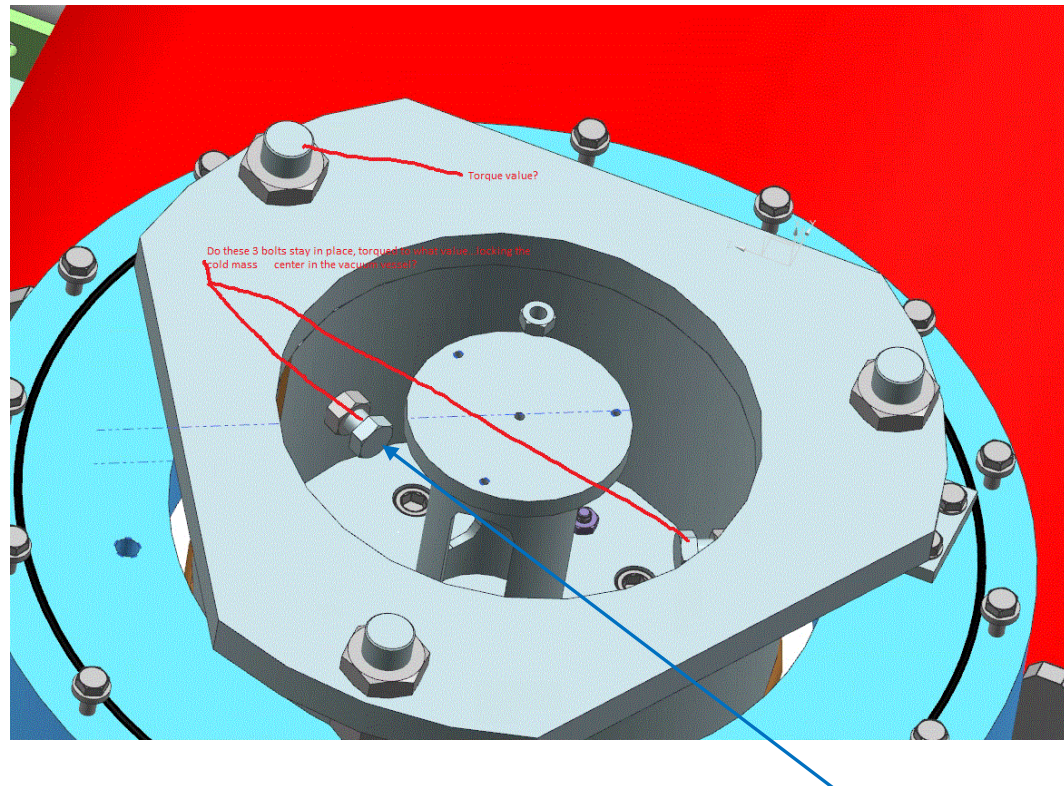

Bring the cavity string beam axis to the designed z (longitudinal) position wrt. vacuum vessel (VV) by using the along the vessel push bolts.

# Final Cavity Alignment at WS4

## Final Cavity Alignment and Cod Offset

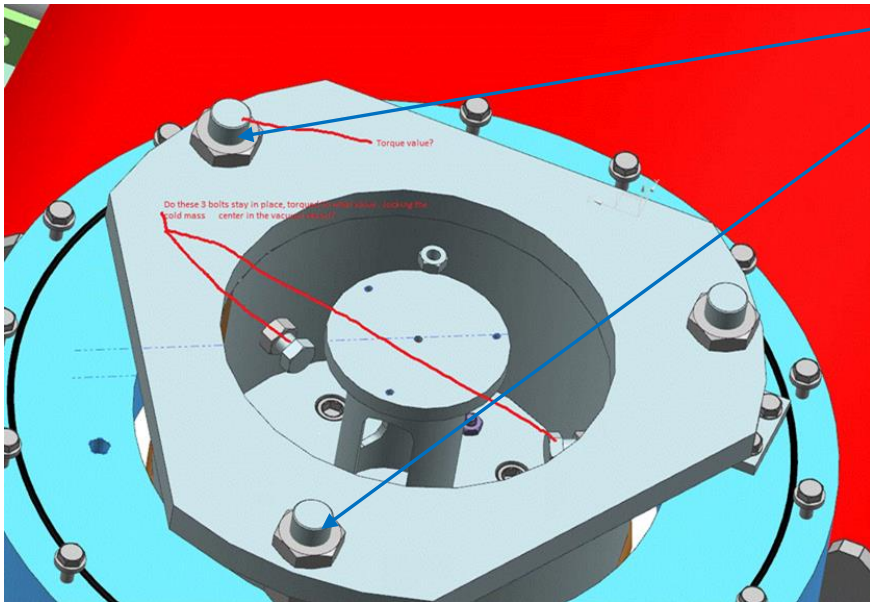

Bring the 2 posts into a plane normal to local gravity and at such a height that the cavity string beam axis is at the designed vertical offset from the VV center. Use the up and down bolts.

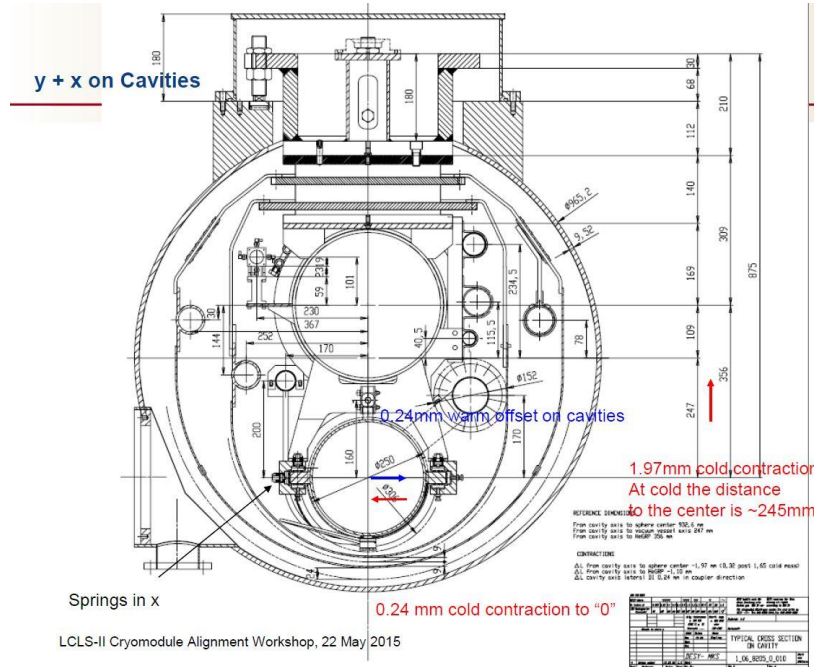

# Lessons Learned that will be applied to 3.9GHz CM assembly at WS4

- MLI pre-made blankets
- Full incoming QC of the vacuum vessel, especially sealing surfaces for the O-rings
- RF measurements and full electrical checks after cold mass is inserted into the vacuum vessel before the alignment
- Tightening and torqueing scheme and sequence of the cold mass support fasteners to ensure contraction/expansion and also secure the cold mass inside the vacuum during CM transport

*Fixture support, all the fasteners (vertical & horizontal) are in contact with vacuum vessel, torqued to spec*

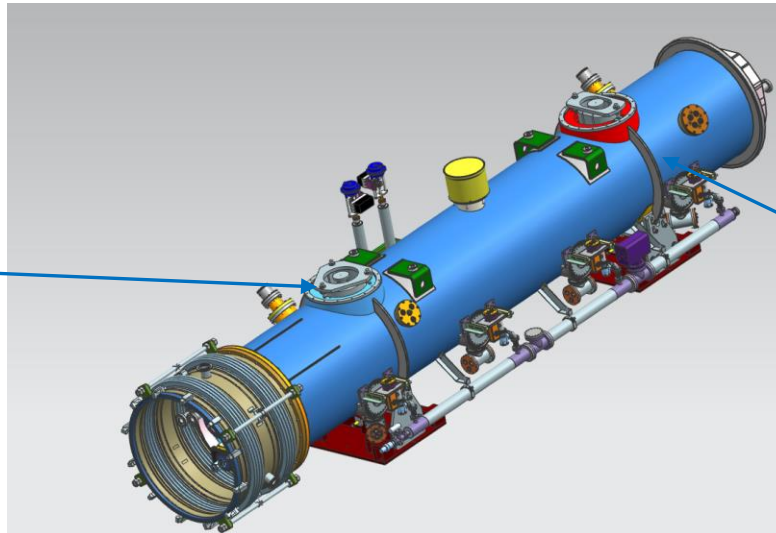

*Sliding support horizontal fasteners have a 0.075 mm gap, not in contact with vacuum vessel*

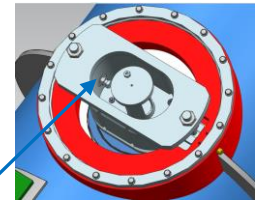

# Cryogenics Valves Welding at WS5

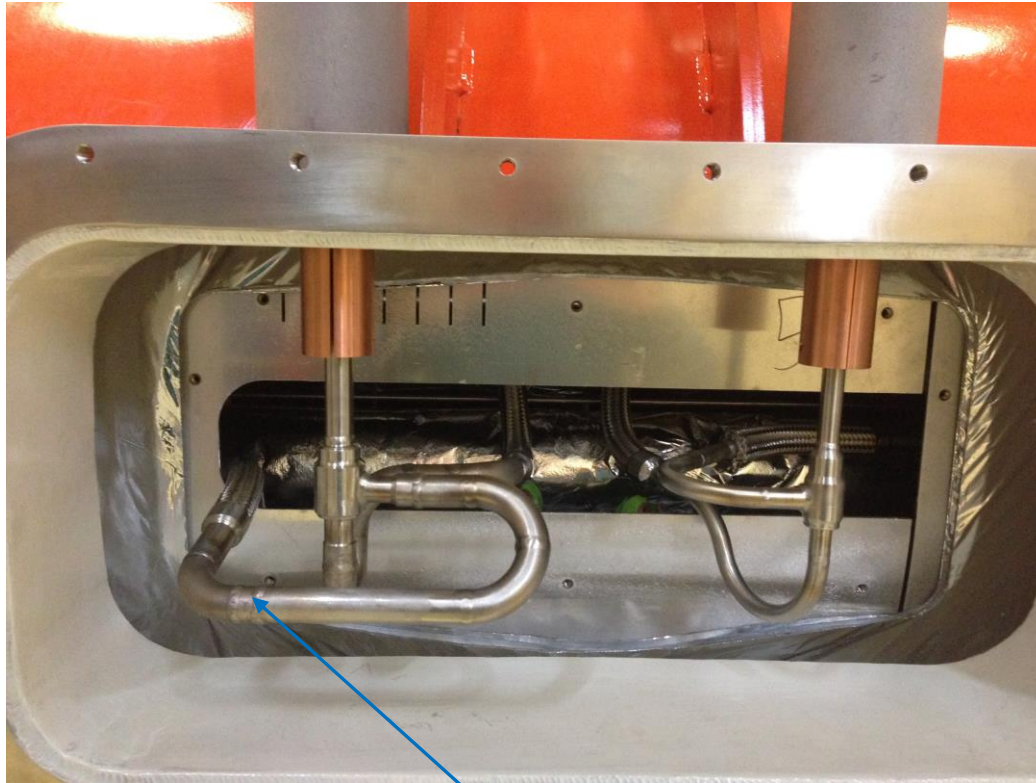

X-ray location

1. Welding Phase-I
2. Leak check
3. High Pressure Test
4. Welding Phase-II
5. Leak Check
6. X-ray QC
7. Low Pressure test

*JT and CD valves assembly same as 1.3 GHz: Established procedures for welding, leak checks, pressure tests, X-ray QC*

## Lessons Learned that will be applied to 3.9GHz CM assembly at WS5

---

- Increased attention for fasteners locking mechanism (at least two such as torqueing, lock washers, Belleville washers, Loctite etc. to prevent loosening during operation and transport
- N-type RF connectors (hermetically sealed) vacuum leak tightness reliability with proper torqueing of the connectors on the bench then during installation of the RF cables
- Insulating vacuum leak check duration shortening with optimized pumps/purge setup and ICB production floor doors, exhaust/ceiling fans configuration to minimize helium background contamination negative effects

# 3.9 GHz Cryomodule Assembly at WS5

Warm End Couplers , Waveguides, Coupler pumping lines, Instrumentation flanges installation

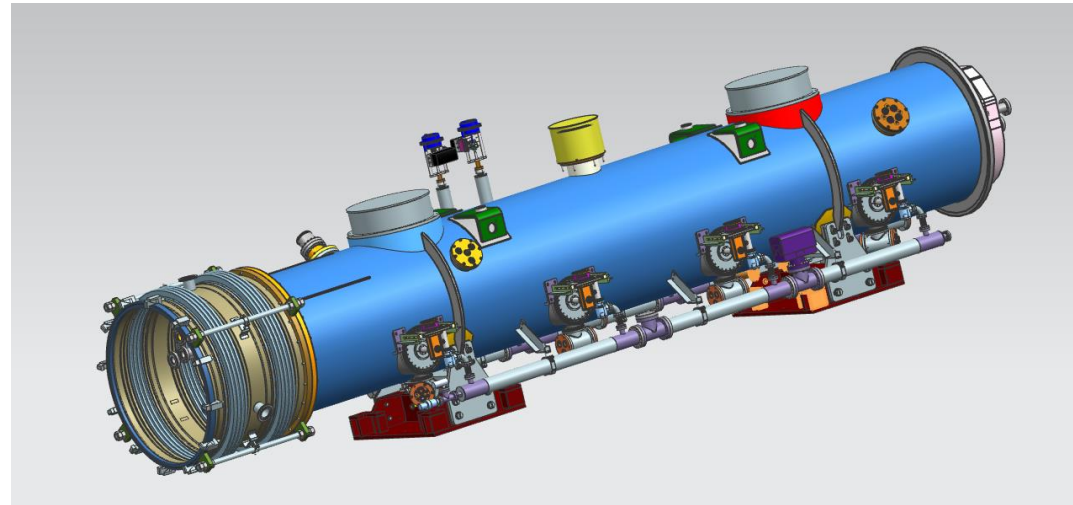

Insulating vacuum leak check, beamline leak check are performed at this workstation prior transporting completed CM to CMTF for testing



# Assembly Drawings

---

- F10014812-D;1-ASSEMBLY, 3.9GHz CAVITY STRING
- F10014819-B;1-ASSEMBLY, 3.9 COLDMASS
- F10014857-C;1-ASSEMBLY, 3.9GHz CRYOMODULE  
LCLS-II

# Travelers

## 3.9 GHz Production Cryomodule Traveler Flow Chart

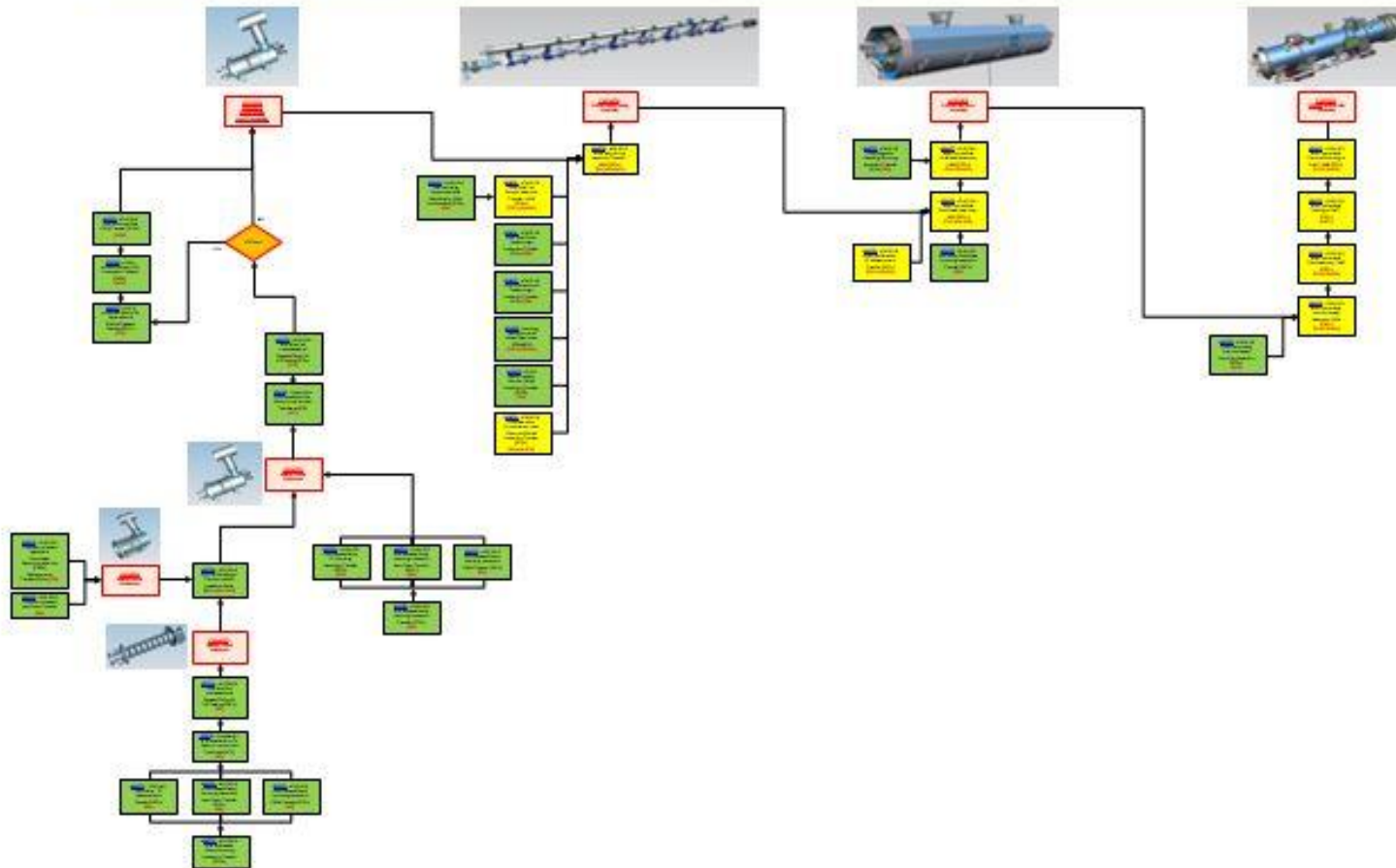

# WS1 through WS5 master travelers (in progress)

---

464480 - NONE - LCLS-II 3.9 GHz Beamline Components - Leak Check and Visual Inspection Traveler (RFCH)

464434 - A - LCLS-II 3.9 GHz Incoming Acceptance and Receiving for Cold End Couplers (RFCH)

464481 - NONE - LCLS-II 3.9 GHz Cold End Coupler Assembly Traveler – WS1 (RFCH)

464356 - NONE - LCLS-II 3.9 GHz Cavity String Assembly Traveler - WS1 (RFCH)

464416 - NONE - LCLS-II 3.9 GHz Cryomodule Cold Mass Assembly - WS2 (RFCH)

464417 - NONE - LCLS-II 3.9 GHz Cryomodule Cold Mass Assembly – WS3 (RFCH)

464419 - NONE - LCLS-II 3.9 GHz Cryomodule Vacuum Vessel Assembly - WS4 (RFCH)

464420 - NONE - LCLS-II 3.9 GHz Cryomodule Final Assembly – WS5 (RFCH)

464418 - NONE - LCLS-II 3.9 GHz Cryomodule Vacuum Vessel Incoming Inspection (RFCH)

464415 - NONE - LCLS-II 3.9 GHz Upper Cold Mass Incoming Inspection Traveler (RFCH)

# Parts Kit Lists (MBOM)

- We are in process of checking/ verifying that all the parts/hardware are ordered, received and QC'ed.
- Parts kit lists are being created
- Parts/hardware are stored at Technical Division (TD) Storage Areas and are organized by the TD inventory management systems
- When a kit is requested by the production floor, LCLS-II supply chain manager will ensure that the parts/hardware are kitted as specified and the kit is delivered to the specific work station
- This system is established well and it currently works seamlessly for 1.3GHz CM production.

Process Engineering				Material Control			
Component Serial No				Parts available			
Cavity String LCLS II				Verified by:			
Kit submitted by:				Fermi ID No:			
Fermi ID No:				Date submitted to stockroom:			
Date submitted:				Parts issued			
Need date:				Issued by:			
Deliver to: MP9				Fermi ID No:			
Use with Traveler No: 464179				Date issued:			
Job No: 571				Parts received by E&F:			
M&S task number:				Fermi ID No:			
Drawing Title: ASSEMBLY, CAVITY STRING LCLS-II (eBOM)				Date received by E&F:			
Drawing No: F10041166 A							

Description	Dwg Size	Number	Rev	Unit	Quantity Required	Location	Quantity Issued	E&F Verified	Routing Form Number	Spares Number / Comment
1 ASSEMBLY, 1.3GHZ CAVITY LCLS-II		F10041054		ea	8					
2 WELDMENT EXTENSION DS		F10052775		ea	1					
3 WELDMENT EXTENSION US		F10041117		ea	1					
4 WELDMENT BELLOWS LONG		F10041075		ea	7					
5 WELDMENT BELLOWS SHORT		F10023437		ea	1					
6 ASSEMBLY FLANGE END-ADAPTOR		F10023441		ea	2					
7 RIGHT ANGLE VALVE DN40, 1-1/2"		FC0027311		ea	1					
8 HHCS, M6x1x25LGxFT - SS316		FC0008126		ea	6					
9 WASHER, M6X1.4 - SS16		FC0016224		ea	6					
10 SEAL, 2.75" CF FLANGE, COPPER C10100		FC0019006		ea	1					
11 SEAL, O-RING, 1.3GHZ		FC0000000		ea	1					

Excerpt from the 1.3GHz CM cavity string assembly at WS1 parts kit list

# Summary

---

- CAF infrastructure is a proven, fully operational facility to assemble 1.3GHz and 3.9GHz cryomodules.
- Each work station infrastructure is ready for the LCLS-II CMs assembly.
- To date, we have completed the assembly of 15 1.3GHz CM. 14 CMs are tested at CMTF. 2 CMs are delivered to SLAC successfully. 3 CMs are currently being assembled.
- 3.9GHz CMs will be assembled when we complete the 1.3GHz Production CM assembly at CAF. Trained and experienced technician workforce is in place.
- We will use the same tooling/fixtures from the 1.3GHz CM for 3.9GHz CM with reconfiguration as needed. String assembly tooling is in house. We are in process for tooling shake down and verify the PFFA assembly procedures for cavity string assembly.