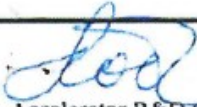
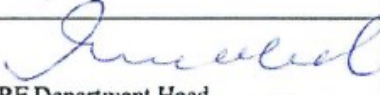
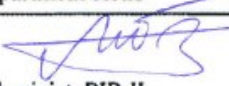


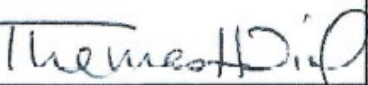
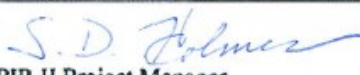
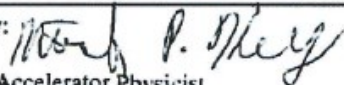
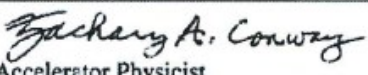
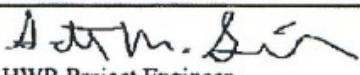


# **TECHNICAL SPECIFICATION FOR THE INTERFACES OF THE FNAL PROJECT-X HALF-WAVE RESONATOR CRYMODULE**



**Argonne**  
NATIONAL  
LABORATORY

11 April 2014  
Argonne National Laboratory  
Physics Division  
9700 S. Cass Avenue  
Argonne, IL 60439  
Ph: (630) 252-0874  
Fax: (630) 252-9647

Prepared by: Z.A. Conway	ANL-PHY Linac Development	Phone Number: 1-630-252-0874
Approved by:  P.N. Ostroumov, Accelerator R&D Group Leader, Senior Accelerator Physicist	ANL-PHY Linac Development	Phone Number: 1-630-252-4897
Approved by:  V.P. Yakovlev, SRF Department Head	Fermilab TD/SRF	Phone Number: 1-630-840-3888
Approved by:  V.A. Lebedev, Senior Physicist, PIP-II	Fermilab AD	Phone Number: 1-630-840-2258
Approved by:  J. Leibfritz, Engineer	Fermilab AD	Phone Number: 1-630-840-8779
Approved by:  A. Klebaner, Engineer	Fermilab AD	Phone Number: 1-630-840-8357
Approved by:  T. Nicol, Engineer	Fermilab TD/SRF Dep.	Phone Number: 1-630-840-3441
Approved by:  S.D. Holmes, PIP-II Project Manager	Fermilab APC/Project X	Phone Number: 1-630-840-3988
Approved by:  M.P. Kelly, Accelerator Physicist	ANL-PHY Linac Development	Phone Number: 1-630-252-4039
Approved by:  Z.A. Conway, Accelerator Physicist	ANL-PHY Linac Development	Phone Number: 1-630-252-0874
Approved by:  S.M. Gerbick, HWR Project Engineer	ANL-PHY Linac Development	Phone Number: 1-630-252-6753

## Table of Contents

<b>1. Scope of Work .....</b>	<b>4</b>
<b>2. Beam Line Connections.....</b>	<b>4</b>
<b>3. Alignment.....</b>	<b>6</b>
<b>4. Magnet Leads .....</b>	<b>9</b>
<b>5. Thermometry and Heaters .....</b>	<b>10</b>
<b>6. He System Instrumentation and Bayonets.....</b>	<b>21</b>
<b>7. Cavity and Cryomodule Vacuum Systems.....</b>	<b>25</b>
<b>8. RF System Connections.....</b>	<b>32</b>
<b>9. Slow Tuner Connections .....</b>	<b>34</b>
<b>10. BPM Connections .....</b>	<b>36</b>
<b>11. Lifting Attachment Points .....</b>	<b>36</b>
<b>12. Cryomodule Location and Required Clearance ..</b>	<b>37</b>

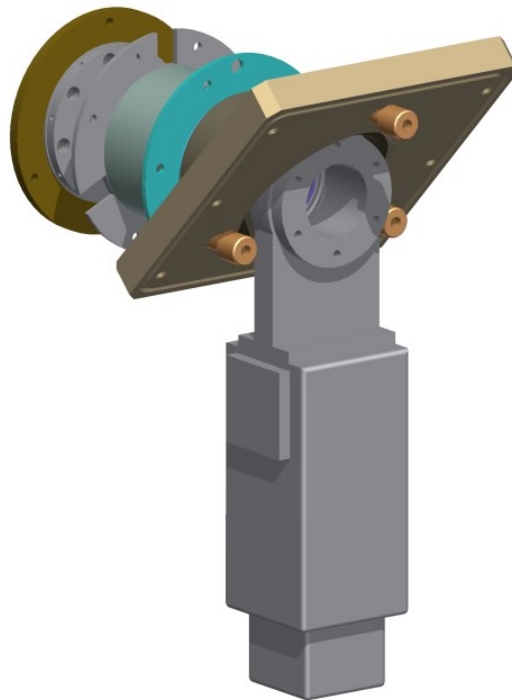
## 1. Scope of Work

This interface specification document defines the requirements related to the interface between the half-wave resonator (HWR) cryomodule of the PIP-II Injector Experiment and the accelerator facilities at Fermi National Accelerator Laboratory (Fermilab). The interface between the HWR cryomodule and the accelerator facilities comprises: beam-line connections, alignment targets and fiducials, magnet leads, thermometry located in the insulating vacuum, heaters located in the insulating vacuum, instrumentation located in the helium system, the low-particulate cavity vacuum system, the cryomodule vacuum system, RF pick-up connections, RF power coupler connections, auxiliary interfaces for the power couplers, slow tuner electric and pneumatic connections, helium cryogenic connections, BPM connections, and lifting connections.

## 2. Beam Line Connections.

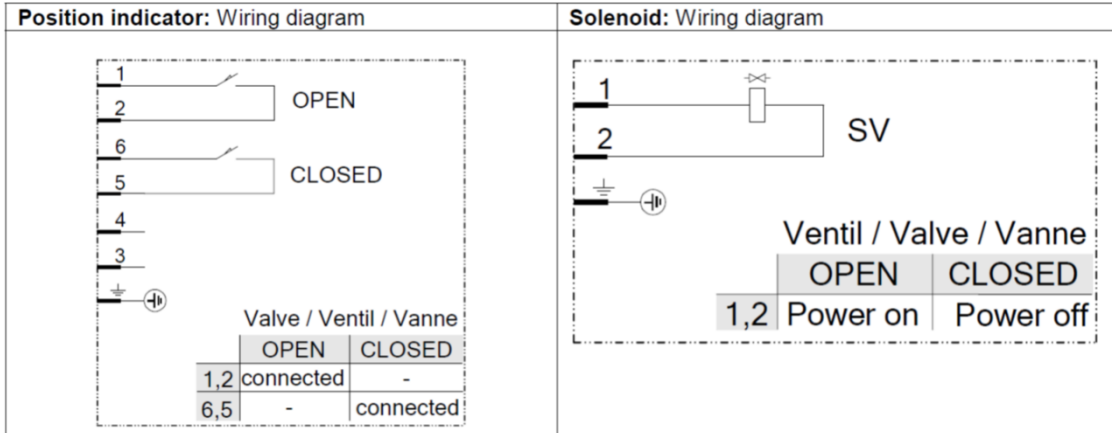
The cryomodule will have low-particulate gate valves attached to the ends of the accelerator structure at the cold-to-warm transitions. The Argonne cryomodule end wall design utilizes a dogleg which allows the complete beam-line assembly to drop into the vacuum vessel while hermetically sealed and under vacuum. The beam-line gate valves pass through holes in the angled end walls where a flanged adapter plate seals against the vacuum vessel. Each of the beam-line valves will have 2 3/4" Con-Flat type flanges with 1/4"-28 blind tapped holes with a minimum threaded depth of 1/4" for attaching adjacent accelerator beam lines (see Appendix 1 for typical Con-Flat Flange Specifications). Each valve will be actuated via control of a solenoid valve and be equipped with a 1/8" NPT connection for compressed air (80 PSIG), a +24 VDC connector and a mechanical position indicator. Figures 2.1 shows the assembly, Figure 2.2 shows the wiring diagram for the solenoid valve and mechanical position indicator, Table 2.1 lists the hardware to be used and Table 2.2 and 2.3 list the solenoid valve and the position indicator connector pin diagrams.

The assembly uses VAT valve P/N: 01032-UE41. This valve



**Figure 2.1: Model view of the low-particulate beam-line gate valve assembly showing the cold to warm transitions, the angled end-plate, the gate-valve body and the port for a 2 3/4" Con Flat type flange.**

uses a pneumatic actuator with a 24 VDC solenoid valve complimented with a single acting closing spring. The beam-line seal is a Viton o-ring and the bonnet seal is copper. The valve has a 0.7 second closing time with nominal air pressure of 80 PSIG supplied to the system. Please refer to the step file solid model for layout and dimensions. Similar assemblies have been in use at ATLAS for more than 5 years. An example is shown in Figure 2.3 and an identical penetration will be supplied for this cryomodule.



**Figure 2.2: Connector layouts for the gate valve solenoid actuator and mechanical position indicator.**

**Table 2.1: Beam line gate valve interface hardware.**

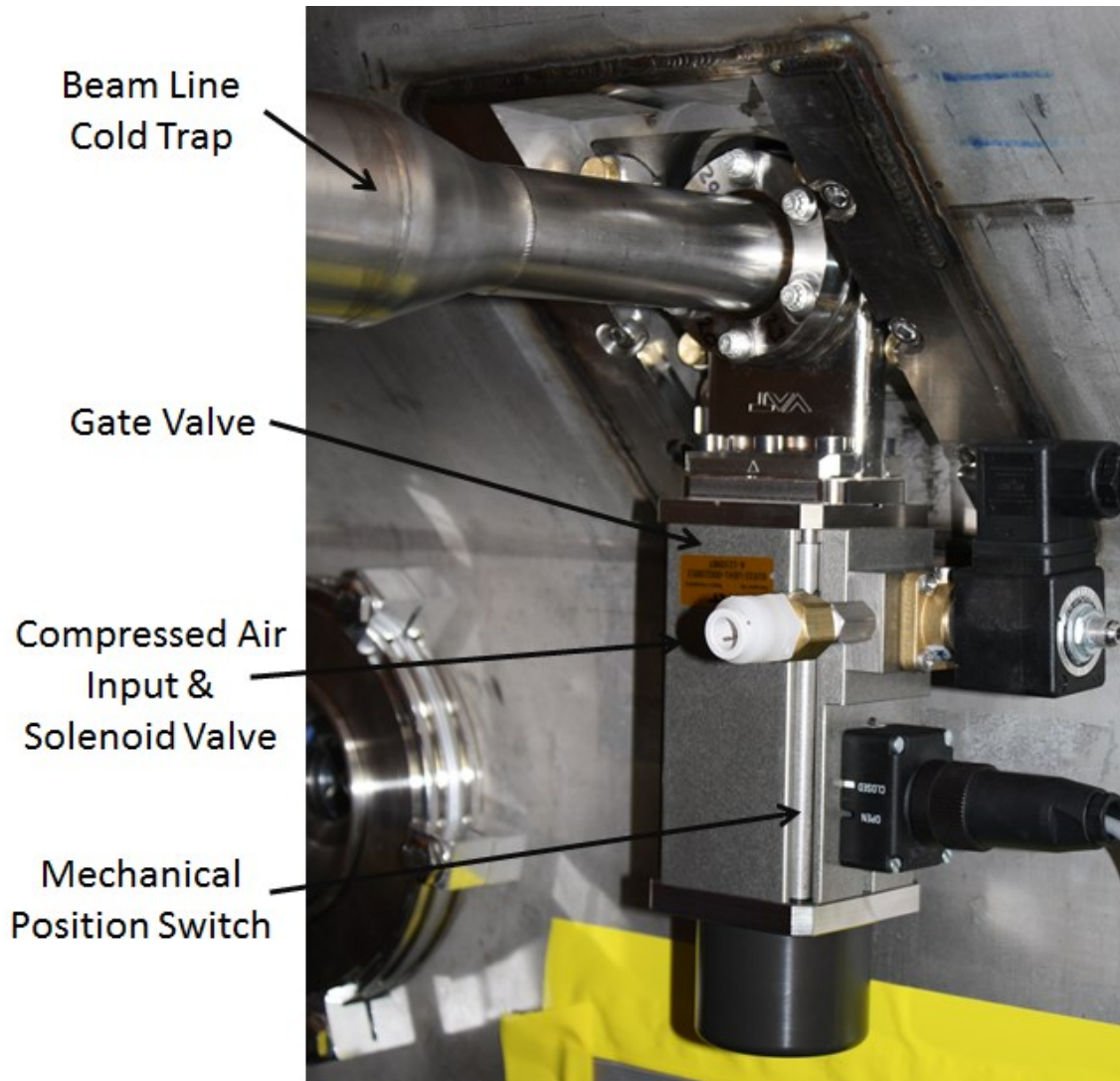
Component	Part Number	Description
VAT Valve	01032-UE41	Low-Particulate Gate Valve
Compressed Air Fitting	1/8" NPT Female	Fitting for 80 PSIG Air
Solenoid Valve	Amphenol MS3101A-14S-6P	Solenoid Actuator Power
Position Indicator	Amphenol MS3101A-14S-6P	Position Switch Connector

**Table 2.2: MS3101A-14S-6P Connector Pin Diagram for the Solenoid Valve.**

Pin	Description
A	+24VDC
B	Common
C	Not Connected
D	Not Connected
E	Not Connected
F	Not Connected
Free Wire	Ground

**Table 2.3: MS3101A-14S-6P Connector Pin Diagram for the Position Indicator.**

Pin	Description
A	Open
B	Open Common
C	Not Connected
D	Not Connected
E	Closed Common
F	Closed
Free Wire	Ground



**Figure 2.3: Beam-line gate valve installed on the 72 MHz quarter-wave cavity cryomodule in ATLAS at ANL. An identical installation has been in service since 2009 on the 109 MHz quarter-wave cavity cryomodule.**

### **3. Alignment**

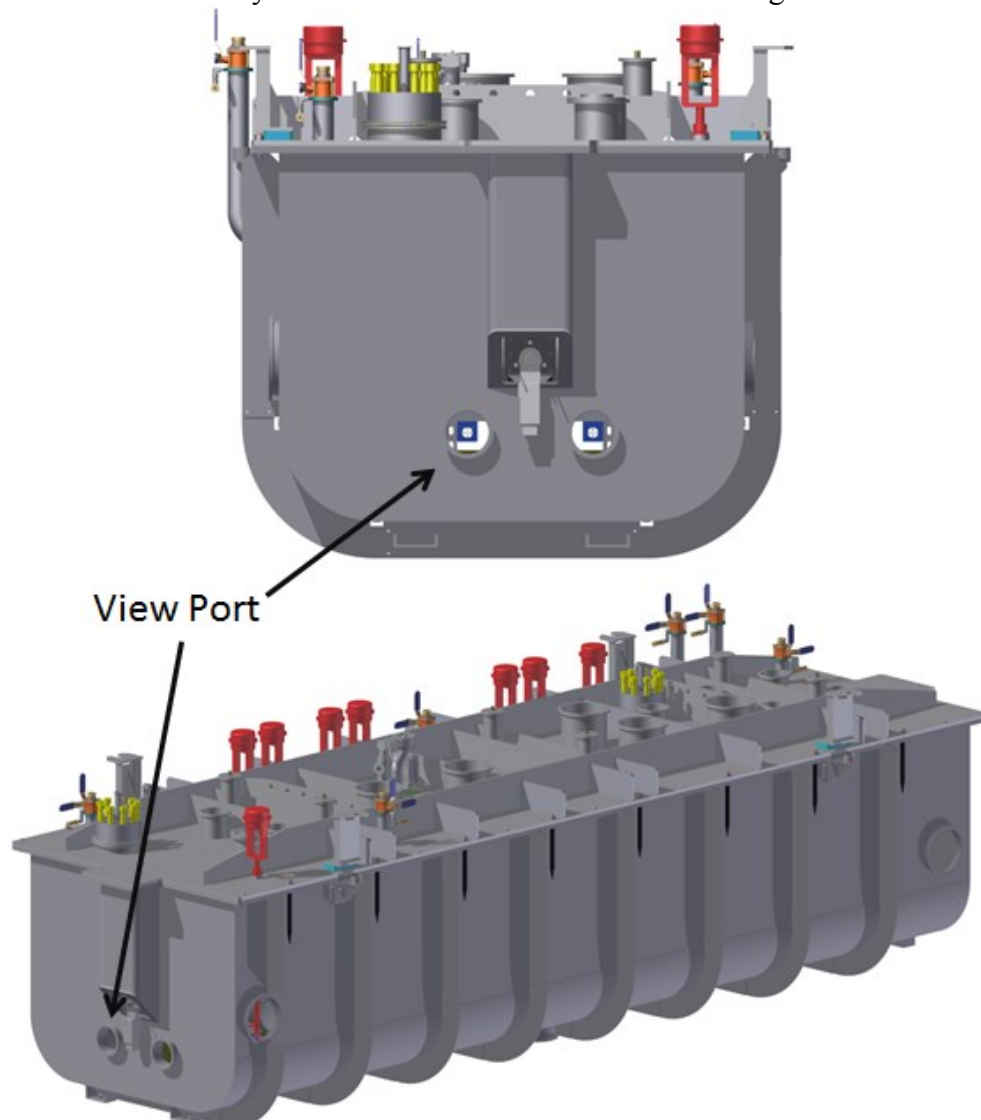
The alignment interfaces may be divided into two areas: interfaces for measuring the alignment of the beam-line components; and interfaces for supporting and aligning the entire cryomodule. First, each HWR and magnet will be equipped with 4 open wire targets all of which will be viewable through ports located on the end-walls of the cryomodule. The cryomodule viewports will be type K ISO160 flanges with quartz viewing windows attached. Please note that type K refers to the flanges being clamped o-ring connections. Figure 3.1 shows the cryomodule end-wall and the view of the open wire targets. The cryomodule vacuum vessel will be equipped with 4 rigid mounting provisions for laser tracker compatible fiducials, e.g., SMR nests. Figure 3.2 shows the fiducial block layout and their locations on the cryomodule. These targets will require metrology measurements to correlate their position with that of the room temperature



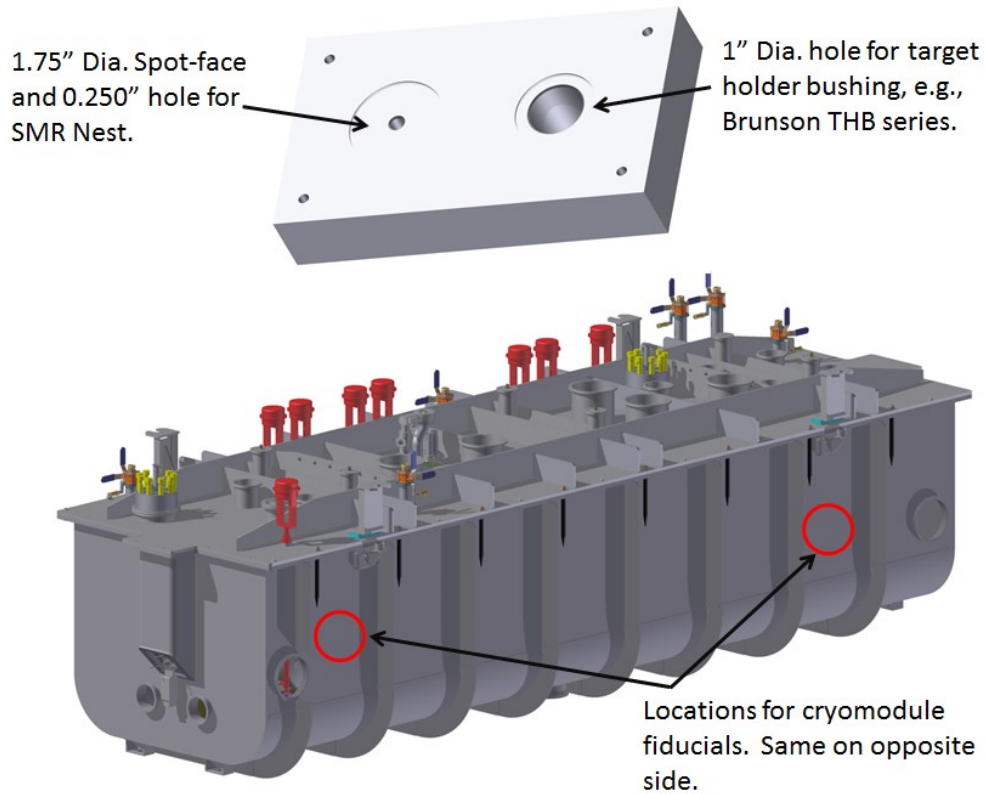
position of the beam line components. After these measurements they may be used for rough alignment of the cryomodule in the beam line.

The cryomodule will have 4 mounting brackets welded to the bottom with 1.25" clearance holes for the attachment of supports with positioning hardware. Figure 3.3 shows the underside of the cryomodule and the location of the four 1.25" diameter clearance holes/brackets for supporting and aligning the cryomodule. Please note that the cryomodule alignment system must not interfere with the power coupler operation, penetrations for which are located immediately next to the mounting brackets.

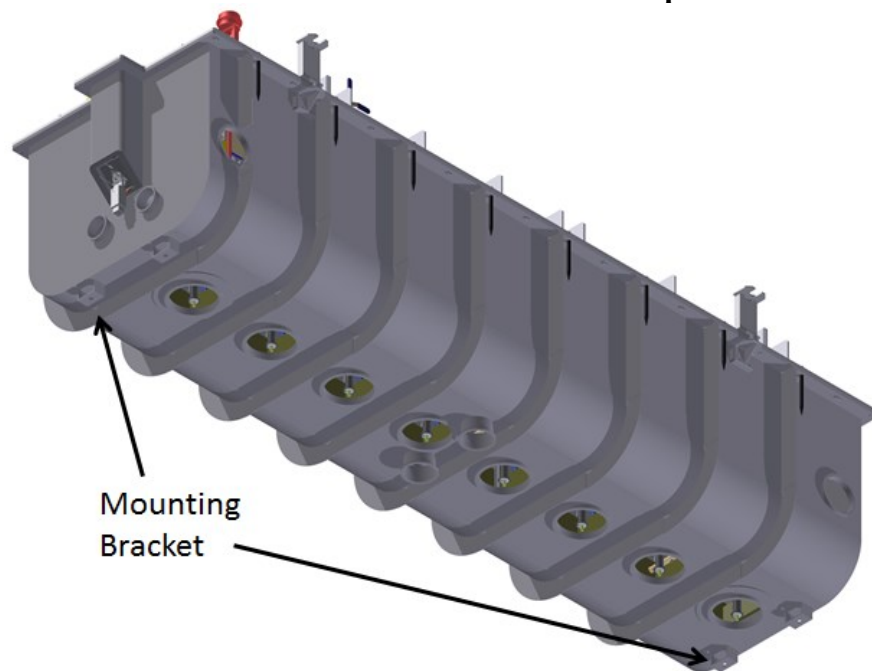
Table 3.1 summaries the hardware to be used for the alignment monitoring. All of this hardware is commercially available from Brunson Instrument Company located in Kansas City, Missouri. Figure 3.4 shows the hardware installed on the new 72 MHz quarter-wave resonator cryomodule which is now installed and aligned in ATLAS.



**Figure 3.1: End view (Top) and perspective view (Bottom) of the HWR cryomodule showing the view ports for access to the open wire targets mounted on all cavities and magnets.**

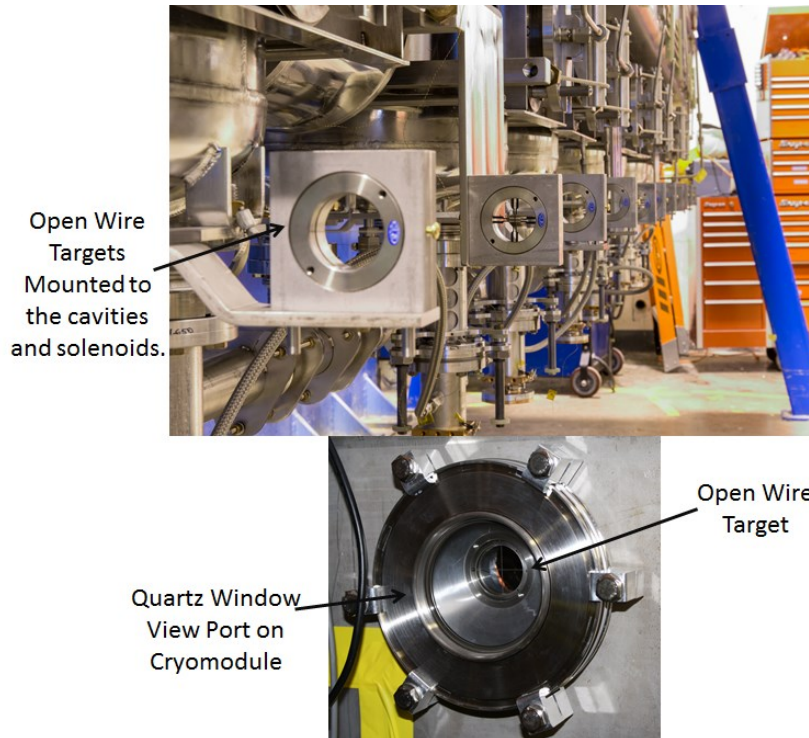


**Figure 3.2: (Top) Cryomodule fiducial mount and (Bottom) locations on cryomodule. Please note that the exact locations may vary in fabrication and final locations will have to be measured after fabrication is complete.**



**Figure 3.3: The underside of the cryomodule and the location of the four 1.25" diameter clearance holes/brackets for supporting and aligning the cryomodule.**





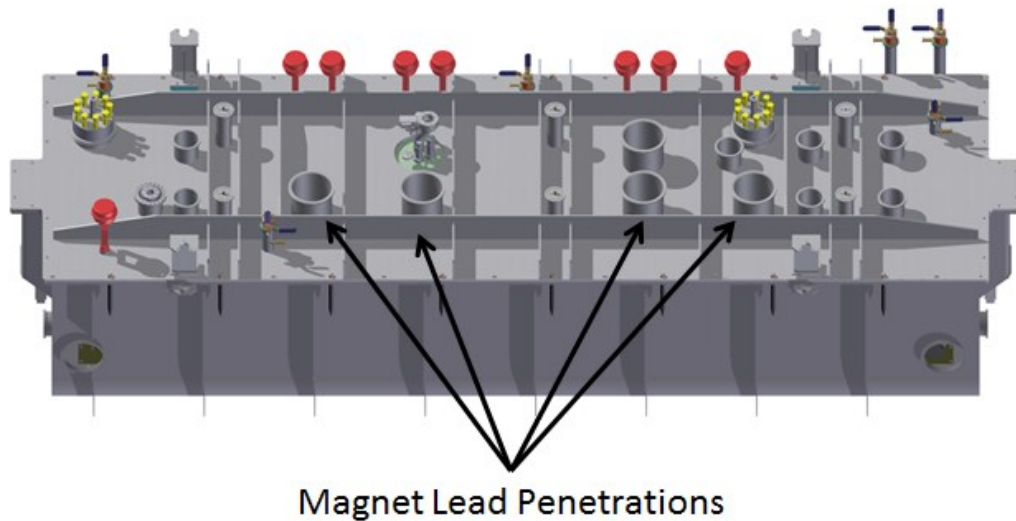
**Figure 3.4: Top, open wire alignment targets installed on all of the cavities and solenoids in the new 72 MHz quarter-wave resonator cryomodule at ATLAS. All of these targets are fiducialized relative to the beam axis of each device. Bottom, a quartz view-port used to view the targets when the beam-line assembly is installed inside the cryomodule vacuum vessel.**

**Table 3.1: Alignment Hardware Summary**

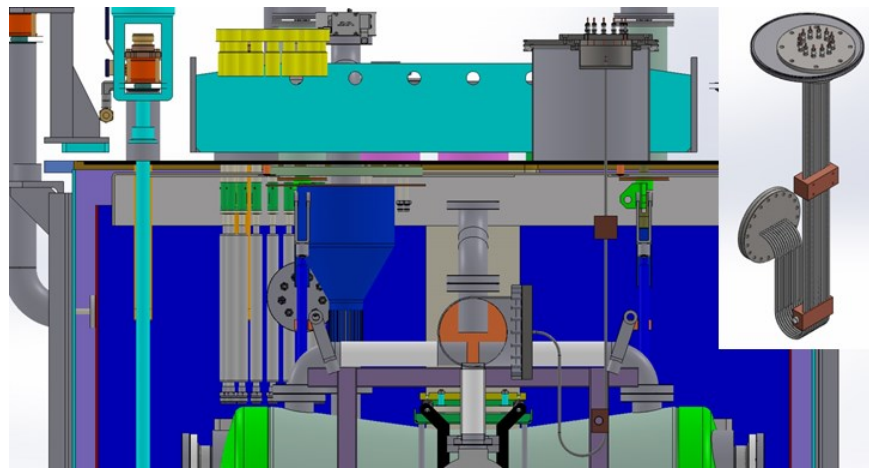
Description	Supplier	Part Number
Magnet Targets	Brunson Instrument Corp.	395
Cavity Targets	Brunson Instrument Corp.	395
Cryomodule Fiducial Holders	Brunson Instrument Corp.	1.5TH and THB
Cryomodule Viewports	Kurt J. Lesker	VPZL-160

## 4. Magnet Leads

The HWR cryomodule houses 8 superconducting magnet packages each comprised of a 6 T superconducting solenoid and two dipole steering coils (x & y) for a total of 6 leads per magnet. The 48 lead interfaces are located on the lid of the cryomodule and are shown in Figure 4.1. The four magnet feedthrough assemblies with lid interface feedthrough plates have been designed by T. Nicol (FNAL). The interface is identical to that used in the single spoke cryomodule located downstream of the HWR cryomodule. Figure 4.2 shows one lead assembly for 12 of the 48 leads and its position in the cryomodule. Each lead is accessible at a hermetic ceramic electrical feedthrough arranged in groups of 12.



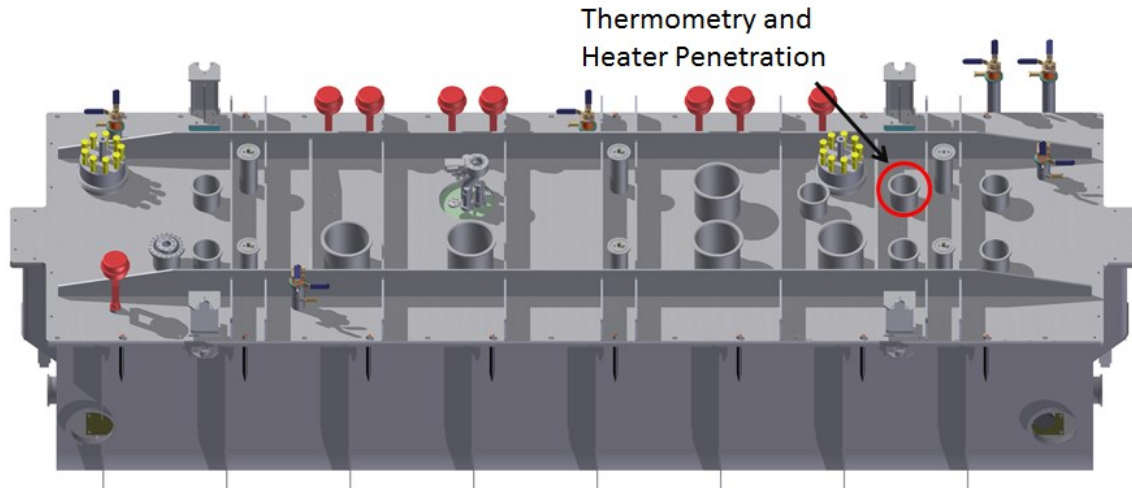
**Figure 4.1: Lid penetrations for the magnet leads.**



**Figure 4.2: Layout of the magnet leads and the lead assembly (inset).**

## 5. Thermometry and Heaters

Thermometry and heaters for the cryomodule are located both inside the insulating vacuum space and inside the liquid helium system. Figure 5.1 shows the location of the electrical connections on the cryomodule lid. Table 5.1 lists the location of all thermometers and the thermometer type. Table 5.2 lists the location of all heaters and the heater type. Table 5.3 lists the thermometry connectors and their 4-lead wiring. Table 5.4 lists the heater connectors and their pin wiring. Please note that all of the thermometers on surfaces which are expected to be 70 K or colder are Cernox RTDs while the warmer surfaces have platinum RTDs. Figure 5.2 shows one of the feedthroughs installed on an ATLAS cryomodule. Feedthroughs of this type will be used for the heaters and the thermometers on the HWR cryomodule.



**Figure 5.1: the port for the thermometry and heater connections on the cryomodule lid.**

**Table 5.1: thermometer locations and type to be used in the HWR cryomodule. The thermometers are either Platinum Resistance Thermometers (PRT) or Cernox thin film resistance cryogenic temperature sensors which are available from Lakeshore Cryotronics. Thermometers located in the helium system are listed in Table 5.3.**

Thermometer Number	Placement	Thermometer Type	P/N
1	Input Valve 80K Intercept	PRT	PT-102
2	Input valve 5K Intercept	Cernox	CX-1050
3	Solenoid 1 Cooldown Fitting	Cernox	CX-1050
4	Cavity 1 Top	Cernox	CX-1050
5	Cavity 1 Slow Tuner 80K	PRT	PT-102
6	Cavity 1 Bottom	Cernox	CX-1050
7	Cavity 1 Coupler 80K	PRT	PT-102
8	Cavity 1 Coupler 5K	Cernox	CX-1050
9	Solenoid 2 Cooldown Fitting	Cernox	CX-1050
10	Cavity 2 Top	Cernox	CX-1050
11	Cavity 2 Slow Tuner 80K	PRT	PT-102
12	Cavity 2 Bottom	Cernox	CX-1050
13	Cavity 2 Coupler 80K	PRT	PT-102
14	Cavity 2 Coupler 5K	Cernox	CX-1050
15	Solenoid 3 Cooldown Fitting	Cernox	CX-1050
16	Cavity 3 Top	Cernox	CX-1050
17	Cavity 3 Slow Tuner 80K	PRT	PT-102
18	Cavity 3 Bottom	Cernox	CX-1050
19	Cavity 3 Coupler 80K	PRT	PT-102
20	Cavity 3 Coupler 5K	Cernox	CX-1050
21	Solenoid 4 Cooldown Fitting	Cernox	CX-1050

22	Cavity 4 Top	Cernox	CX-1050
23	Cavity 4 Slow Tuner 80K	PRT	PT-102
24	Cavity 4 Bottom	Cernox	CX-1050
25	Cavity 4 Coupler 80K	PRT	PT-102
26	Cavity 4 Coupler 5K	Cernox	CX-1050
27	He Manifold 80 K Thermal Intercept	PRT	PT-102
28	He Manifold 5 K Thermal Intercept	Cernox	CX-1050
29	Helium Manifold Pipe	Cernox	CX-1050
30	Lid Heat Shield	PRT	PT-102
31	Slow Tuner HTXG	PRT	PT-102
32	Vacuum Vessel Heat Shield Side 1	PRT	PT-102
33	Output Valve 80K Intercept	PRT	PT-102
34	Output valve 5K Intercept	Cernox	CX-1050
35	Solenoid 5 Cooldown Fitting	Cernox	CX-1050
36	Cavity 5 Top	Cernox	CX-1050
37	Cavity 5 Slow Tuner 80K	PRT	PT-102
38	Cavity 5 Bottom	Cernox	CX-1050
39	Cavity 5 Coupler 80K	PRT	PT-102
40	Cavity 5 Coupler 5K	Cernox	CX-1050
41	Solenoid 6 Cooldown Fitting	Cernox	CX-1050
42	Cavity 6 Top	Cernox	CX-1050
43	Cavity 6 Slow Tuner 80K	PRT	PT-102
44	Cavity 6 Bottom	Cernox	CX-1050
45	Cavity 6 Coupler 80K	PRT	PT-102
46	Cavity 6 Coupler 5K	Cernox	CX-1050
47	Solenoid 7 Cooldown Fitting	Cernox	CX-1050
48	Cavity 7 Top	Cernox	CX-1050
49	Cavity 7 Slow Tuner 80K	PRT	PT-102
50	Cavity 7 Bottom	Cernox	CX-1050
51	Cavity 7 Coupler 80K	PRT	PT-102
52	Cavity 7 Coupler 5K	Cernox	CX-1050
53	Solenoid 8 Cooldown Fitting	Cernox	CX-1050
54	Cavity 8 Top	Cernox	CX-1050
55	Cavity 8 Slow Tuner 80K	PRT	PT-102
56	Cavity 8 Bottom	Cernox	CX-1050
57	Cavity 8 Coupler 80K	PRT	PT-102
58	Cavity 8 Coupler 5K	Cernox	CX-1050
59	Vacuum Vessel Heat Shield Side 2	PRT	PT-102
60	Vacuum Vessel Heat Shield Side 3	PRT	PT-102
61	Vacuum Vessel Heat Shield Side 4	PRT	PT-102
62	Vacuum Vessel Bottom	PRT	PT-102

63	Ti Strong-Back At Hanger Mount	PRT	PT-102
64	Ti Hanger 80K Intercept	PRT	PT-102

**Table 5.2: Heater location and part numbers for the HWR cryomodule. The heaters are 50  $\Omega$  resistors rated to 50 W each. Heaters #25-32 will all be installed on the sub-atmospheric output lines.**

Heater #	Placement	Supplier	P/N
1	Bottom Cavity 1	Caddock	M850-50.0-1%
2	Bottom Cavity 2	Caddock	M850-50.0-1%
3	Bottom Cavity 3	Caddock	M850-50.0-1%
4	Bottom Cavity 4	Caddock	M850-50.0-1%
5	Bottom Cavity 5	Caddock	M850-50.0-1%
6	Bottom Cavity 6	Caddock	M850-50.0-1%
7	Bottom Cavity 7	Caddock	M850-50.0-1%
8	Bottom Cavity 8	Caddock	M850-50.0-1%
9	Bottom Solenoid 1	Caddock	M850-50.0-1%
10	Bottom Solenoid 2	Caddock	M850-50.0-1%
11	Bottom Solenoid 3	Caddock	M850-50.0-1%
12	Bottom Solenoid 4	Caddock	M850-50.0-1%
13	Bottom Solenoid 5	Caddock	M850-50.0-1%
14	Bottom Solenoid 6	Caddock	M850-50.0-1%
15	Bottom Solenoid 7	Caddock	M850-50.0-1%
16	Bottom Solenoid 8	Caddock	M850-50.0-1%
17	Helium Manifold	Caddock	M850-50.0-1%
18	Helium Manifold	Caddock	M850-50.0-1%
19	Helium Manifold	Caddock	M850-50.0-1%
20	Helium Manifold	Caddock	M850-50.0-1%
21	Strong Back	Caddock	M850-50.0-1%
22	Strong Back	Caddock	M850-50.0-1%
23	Strong Back	Caddock	M850-50.0-1%
24	Strong Back	Caddock	M850-50.0-1%

**Table 5.3: Thermometry electrical feedthrough pin layouts. All of the electrical feedthroughs will be supplied by solid sealing technology and will be P/N: FA16523.**

Feedthrough	Pin #	Connection
1	1	Thermometer # 1 I+
1	2	Thermometer # 1 V+
1	3	Thermometer # 1 V-
1	4	Thermometer # 1 I-
1	5	Thermometer # 2 I+
1	6	Thermometer # 2 V+
1	7	Thermometer # 2 V-
1	8	Thermometer # 2 I-
1	9	Thermometer # 3 I+

1	10	Thermometer # 3 V+
1	11	Thermometer # 3 V-
1	12	Thermometer # 3 I-
1	13	Thermometer # 4 I+
1	14	Thermometer # 4 V+
1	15	Thermometer # 4 V-
1	16	Thermometer # 4 I-
1	17	Thermometer # 5 I+
1	18	Thermometer # 5 V+
1	19	Thermometer # 5 V-
1	20	Thermometer # 5 I-
1	21	Thermometer # 6 I+
1	22	Thermometer # 6 V+
1	23	Thermometer # 6 V-
1	24	Thermometer # 6 I-
1	25	Thermometer # 7 I+
1	26	Thermometer # 7 V+
1	27	Thermometer # 7 V-
1	28	Thermometer # 7 I-
1	29	Thermometer # 8 I+
1	30	Thermometer # 8 V+
1	31	Thermometer # 8 V-
1	32	Thermometer # 8 I-
2	1	Thermometer # 9 I+
2	2	Thermometer # 9 V+
2	3	Thermometer # 9 V-
2	4	Thermometer # 9 I-
2	5	Thermometer # 10 I+
2	6	Thermometer # 10 V+
2	7	Thermometer # 10 V-
2	8	Thermometer # 10 I-
2	9	Thermometer # 11 I+
2	10	Thermometer # 11 V+
2	11	Thermometer # 11 V-
2	12	Thermometer # 11 I-
2	13	Thermometer # 12 I+
2	14	Thermometer # 12 V+
2	15	Thermometer # 12 V-
2	16	Thermometer # 12 I-
2	17	Thermometer # 13 I+
2	18	Thermometer # 13 V+
2	19	Thermometer # 13 V-
2	20	Thermometer # 13 I-
2	21	Thermometer # 14 I+
2	22	Thermometer # 14 V+
2	23	Thermometer # 14 V-



2	24	Thermometer # 14 I-
2	25	Thermometer # 15 I+
2	26	Thermometer # 15 V+
2	27	Thermometer # 15 V-
2	28	Thermometer # 15 I-
2	29	Thermometer # 16 I+
2	30	Thermometer # 16 V+
2	31	Thermometer # 16 V-
2	32	Thermometer # 16 I-
3	1	Thermometer # 17 I+
3	2	Thermometer # 17 V+
3	3	Thermometer # 17 V-
3	4	Thermometer # 17 I-
3	5	Thermometer # 18 I+
3	6	Thermometer # 18 V+
3	7	Thermometer # 18 V-
3	8	Thermometer # 18 I-
3	9	Thermometer # 19 I+
3	10	Thermometer # 19 V+
3	11	Thermometer # 19 V-
3	12	Thermometer # 19 I-
3	13	Thermometer # 20 I+
3	14	Thermometer # 20 V+
3	15	Thermometer # 20 V-
3	16	Thermometer # 20 I-
3	17	Thermometer # 21 I+
3	18	Thermometer # 21 V+
3	19	Thermometer # 21 V-
3	20	Thermometer # 21 I-
3	21	Thermometer # 22 I+
3	22	Thermometer # 22 V+
3	23	Thermometer # 22 V-
3	24	Thermometer # 22 I-
3	25	Thermometer # 23 I+
3	26	Thermometer # 23 V+
3	27	Thermometer # 23 V-
3	28	Thermometer # 23 I-
3	29	Thermometer # 24 I+
3	30	Thermometer # 24 V+
3	31	Thermometer # 24 V-
3	32	Thermometer # 24 I-
4	1	Thermometer # 25 I+
4	2	Thermometer # 25 V+
4	3	Thermometer # 25 V-
4	4	Thermometer # 25 I-
4	5	Thermometer # 26 I+

4	6	Thermometer # 26 V+
4	7	Thermometer # 26 V-
4	8	Thermometer # 26 I-
4	9	Thermometer # 27 I+
4	10	Thermometer # 27 V+
4	11	Thermometer # 27 V-
4	12	Thermometer # 27 I-
4	13	Thermometer # 28 I+
4	14	Thermometer # 28 V+
4	15	Thermometer # 28 V-
4	16	Thermometer # 28 I-
4	17	Thermometer # 29 I+
4	18	Thermometer # 29 V+
4	19	Thermometer # 29 V-
4	20	Thermometer # 29 I-
4	21	Thermometer # 30 I+
4	22	Thermometer # 30 V+
4	23	Thermometer # 30 V-
4	24	Thermometer # 30 I-
4	25	Thermometer # 31 I+
4	26	Thermometer # 31 V+
4	27	Thermometer # 31 V-
4	28	Thermometer # 31 I-
4	29	Thermometer # 32 I+
4	30	Thermometer # 32 V+
4	31	Thermometer # 32 V-
4	32	Thermometer # 32 I-
5	1	Thermometer # 33 I+
5	2	Thermometer # 33 V+
5	3	Thermometer # 33 V-
5	4	Thermometer # 33 I-
5	5	Thermometer # 34 I+
5	6	Thermometer # 34 V+
5	7	Thermometer # 34 V-
5	8	Thermometer # 34 I-
5	9	Thermometer # 35 I+
5	10	Thermometer # 35 V+
5	11	Thermometer # 35 V-
5	12	Thermometer # 35 I-
5	13	Thermometer # 36 I+
5	14	Thermometer # 36 V+
5	15	Thermometer # 36 V-
5	16	Thermometer # 36 I-
5	17	Thermometer # 37 I+
5	18	Thermometer # 37 V+
5	19	Thermometer # 37 V-

5	20	Thermometer # 37 I-
5	21	Thermometer # 38 I+
5	22	Thermometer # 38 V+
5	23	Thermometer # 38 V-
5	24	Thermometer # 38 I-
5	25	Thermometer # 39 I+
5	26	Thermometer # 39 V+
5	27	Thermometer # 39 V-
5	28	Thermometer # 39 I-
5	29	Thermometer # 40 I+
5	30	Thermometer # 40 V+
5	31	Thermometer # 40 V-
5	32	Thermometer # 40 I-
6	1	Thermometer # 41 I+
6	2	Thermometer # 41 V+
6	3	Thermometer # 41 V-
6	4	Thermometer # 41 I-
6	5	Thermometer # 42 I+
6	6	Thermometer # 42 V+
6	7	Thermometer # 42 V-
6	8	Thermometer # 42 I-
6	9	Thermometer # 43 I+
6	10	Thermometer # 43 V+
6	11	Thermometer # 43 V-
6	12	Thermometer # 43 I-
6	13	Thermometer # 44 I+
6	14	Thermometer # 44 V+
6	15	Thermometer # 44 V-
6	16	Thermometer # 44 I-
6	17	Thermometer # 45 I+
6	18	Thermometer # 45 V+
6	19	Thermometer # 45 V-
6	20	Thermometer # 45 I-
6	21	Thermometer # 46 I+
6	22	Thermometer # 46 V+
6	23	Thermometer # 46 V-
6	24	Thermometer # 46 I-
6	25	Thermometer # 47 I+
6	26	Thermometer # 47 V+
6	27	Thermometer # 47 V-
6	28	Thermometer # 47 I-
6	29	Thermometer # 48 I+
6	30	Thermometer # 48 V+
6	31	Thermometer # 48 V-
6	32	Thermometer # 48 I-
7	1	Thermometer # 49 I+

7	2	Thermometer # 49 V+
7	3	Thermometer # 49 V-
7	4	Thermometer # 49 I-
7	5	Thermometer # 50 I+
7	6	Thermometer # 50 V+
7	7	Thermometer # 50 V-
7	8	Thermometer # 50 I-
7	9	Thermometer # 51 I+
7	10	Thermometer # 51 V+
7	11	Thermometer # 51 V-
7	12	Thermometer # 51 I-
7	13	Thermometer # 52 I+
7	14	Thermometer # 52 V+
7	15	Thermometer # 52 V-
7	16	Thermometer # 52 I-
7	17	Thermometer # 53 I+
7	18	Thermometer # 53 V+
7	19	Thermometer # 53 V-
7	20	Thermometer # 53 I-
7	21	Thermometer # 54 I+
7	22	Thermometer # 54 V+
7	23	Thermometer # 54 V-
7	24	Thermometer # 54 I-
7	25	Thermometer # 55 I+
7	26	Thermometer # 55 V+
7	27	Thermometer # 55 V-
7	28	Thermometer # 55 I-
7	29	Thermometer # 56 I+
7	30	Thermometer # 56 V+
7	31	Thermometer # 56 V-
7	32	Thermometer # 56 I-
8	1	Thermometer # 57 I+
8	2	Thermometer # 57 V+
8	3	Thermometer # 57 V-
8	4	Thermometer # 57 I-
8	5	Thermometer # 58 I+
8	6	Thermometer # 58 V+
8	7	Thermometer # 58 V-
8	8	Thermometer # 58 I-
8	9	Thermometer # 59 I+
8	10	Thermometer # 59 V+
8	11	Thermometer # 59 V-
8	12	Thermometer # 59 I-
8	13	Thermometer # 60 I+
8	14	Thermometer # 60 V+
8	15	Thermometer # 60 V-

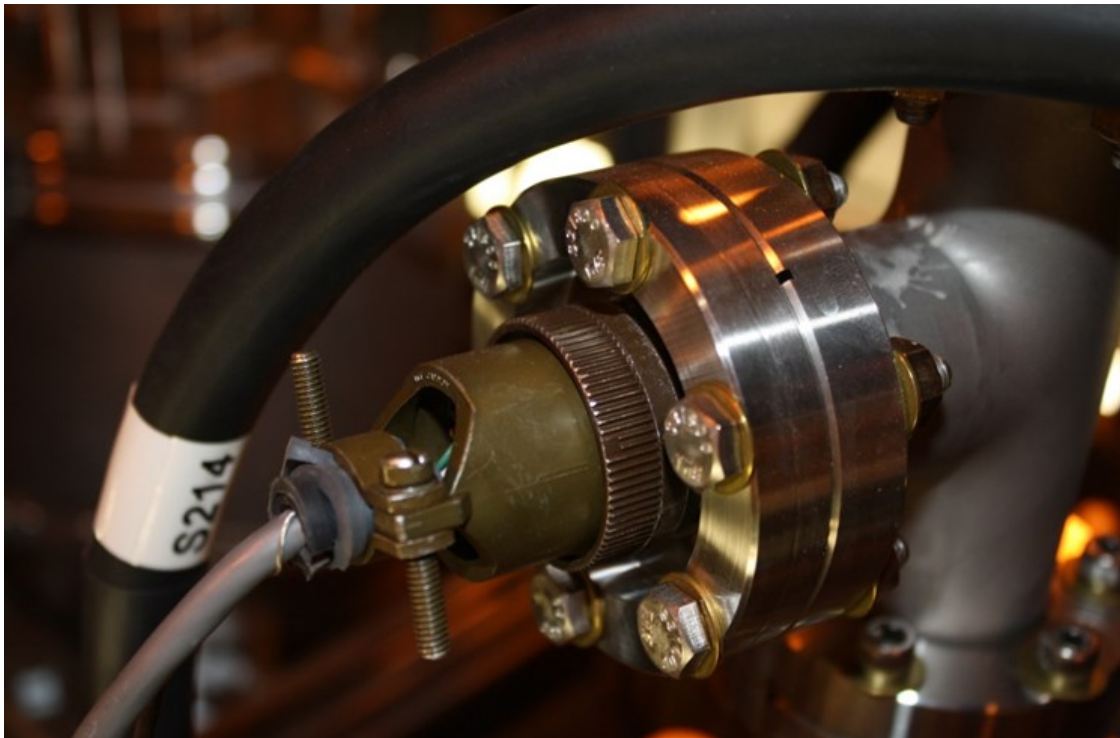
8	16	Thermometer # 60 I-
8	17	Thermometer # 61 I+
8	18	Thermometer # 61 V+
8	19	Thermometer # 61 V-
8	20	Thermometer # 61 I-
8	21	Thermometer # 62 I+
8	22	Thermometer # 62 V+
8	23	Thermometer # 62 V-
8	24	Thermometer # 62 I-
8	25	Thermometer # 63 I+
8	26	Thermometer # 63 V+
8	27	Thermometer # 63 V-
8	28	Thermometer # 63 I-
8	29	Thermometer # 64 I+
8	30	Thermometer # 64 V+
8	31	Thermometer # 64 V-
8	32	Thermometer # 64 I-

**Table 5.4: Heater electrical feedthrough pin layouts. All of the electrical feedthroughs will be supplied by solid sealing technology and will be P/N: FA16523.**

Feedthrough	Pin #	Connection
1	1	Heater # 1 +
1	2	Heater # 1 -
1	3	Heater # 2 +
1	4	Heater # 2 -
1	5	Heater # 3 +
1	6	Heater # 3 -
1	7	Heater # 4 +
1	8	Heater # 4 -
1	9	Heater # 5 +
1	10	Heater # 5 -
1	11	Heater # 6 +
1	12	Heater # 6 -
1	13	Heater # 7 +
1	14	Heater # 7 -
1	15	Heater # 8 +
1	16	Heater # 8 -
1	17	Heater # 9 +
1	18	Heater # 9 -
1	19	Heater # 10 +
1	20	Heater # 10 -
1	21	Heater # 11 +
1	22	Heater # 11 -
1	23	Heater # 12 +
1	24	Heater # 12 -
1	25	Heater # 13 +

1	26	Heater # 13 -
1	27	Heater # 14 +
1	28	Heater # 14 -
1	29	Heater # 15 +
1	30	Heater # 15 -
1	31	Heater # 16 +
1	32	Heater # 16 -
2	1	Heater # 17 +
2	2	Heater # 17 -
2	3	Heater # 18 +
2	4	Heater # 18 -
2	5	Heater # 19 +
2	6	Heater # 19 -
2	7	Heater # 20 +
2	8	Heater # 20 -
2	9	Heater # 21 +
2	10	Heater #21 -
2	11	Heater # 22 +
2	12	Heater # 22 -
2	13	Heater # 23 +
2	14	Heater # 23 -
2	15	Heater # 24 +
2	16	Heater # 24 -
2	17	Heater # 25 +
2	18	Heater # 25 -
2	19	Heater # 26 +
2	20	Heater # 26 -
2	21	Heater # 27 +
2	22	Heater # 27 -
2	23	Heater # 28 +
2	24	Heater # 28 -
2	25	Heater # 29 +
2	26	Heater # 29 -
2	27	Heater # 30 +
2	28	Heater # 30 -
2	29	Heater # 31 +
2	30	Heater # 31 -
2	31	Heater # 32 +
2	32	Heater # 32 -





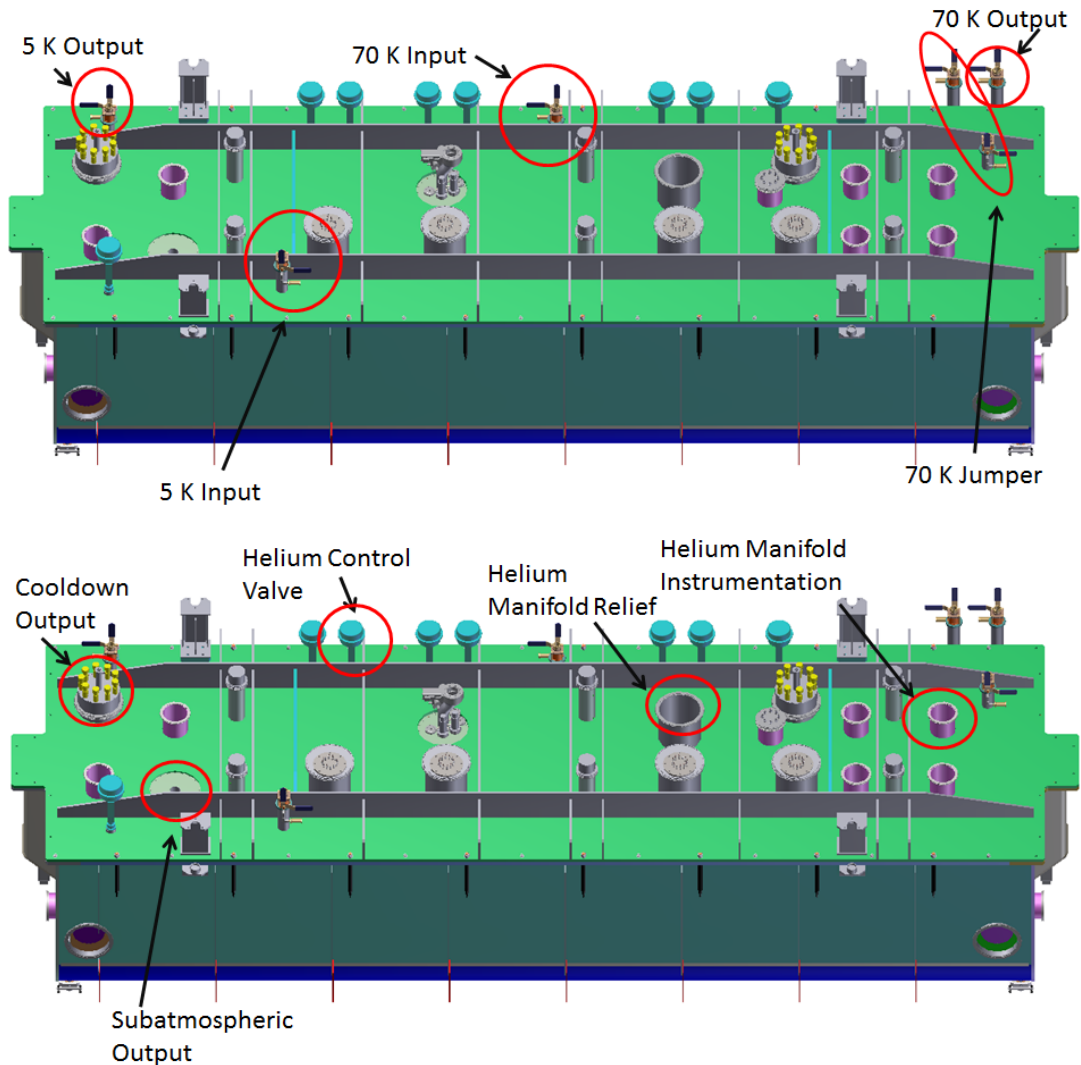
**Figure 5.2: A 32 pin hermetic feedthrough with connector attached used for powering heaters on the 72 MHz quarter-wave cavity cryomodule at ATLAS. Identical feedthroughs and heaters will be used on the HWR cryomodule.**

## **6. He System Instrumentation and Bayonets.**

Here the instrumentation interfaces, the cryogenic control valve interfaces and the cryogenic input/output interfaces are defined. The helium system will be instrumented per the process and instrumentation diagram generated by M. White (FNAL) minus one control valve. Figure 6.1 identifies the location of the interfaces. Tables 6.1 – 6.4 list the bayonet types, the interfaces for the helium instrumentation (e.g., liquid level probes, fitting for mounting pressure transducers, etc), the relief connection and the cooldown manifold control valves.

The cooldown valves will be supplied by CPC-Cryolab and are available as a standard part, P/N: CV9-84CWTRA. There will be one cooldown valve for the titanium strongback and for each individual solenoid and cavity, for a total of 17 valves. Each valve will have the manual handle removed and replaced with a BIMBA pneumatic actuator. Refer to Table 6.4 for the connections required for each of these valves. The helium system uses 8 WEKA DN15 valves configured for normally open operation with pneumatic actuators. These valves are used to throttle the flow of helium coolant through the separate cooling circuits. Refer to Table 6.5 for each valve used and to Table 6.6 for the connections required for each of these valves. Figure 6.3 shows the standard female helium bayonet input, a WEKA valve, Bimba modified cooldown valve actuators and a cool down manifold in use at ATLAS.

The helium relief line will have a WEKA check valve installed in the line. The output will be a 6.75" CF-type flange located at the interface shown in figure 6.1 installed on a 4" schedule 10 pipe.



**Figure 6.1: The location of the helium system interfaces. Top, bayonet locations. Bottom, other interface locations.**

**Table 6.1: Helium bayonets and designated cryogenic stream.**

Bayonet	Use	Drawing #
1	5 K Helium Input	FNAL 1650-MD-257376
2	5 K Helium Output	FNAL 1650-MD-257376
3	70 K Helium Input (Lid)	FNAL 1650-MD-257376
4	70 K Helium Output (Lid)	FNAL 1650-MD-257376
5	70 K Helium Input (Box)	FNAL 1650-MD-257376
6	70 K Helium Output (Box)	FNAL 1650-MD-257376
7	Sub-atmospheric Output	JLAB 75300-E-0034

**Table 6.2: Helium system instrumentation interface list.**

Item	Part	Use	Vendor	Vendor Part #
1	VCR-4 Female Connection	Connections for Pressure Gauge Connection	Swagelok	SS-4-VCR-4 & SS-4-VCR-3
2	VCR-4 Female Connection	Connections for Pressure Gauge Connection	Swagelok	SS-4-VCR-4 & SS-4-VCR-3
3	Electrical Feedthrough	Two liquid level probes, two Cernox sensors and one heater.	Solid Sealing Technologies	FA16523

**Table 6.3: Helium instrumentation electrical feedthrough wiring.**

Pin	Connection
1	Liquid Level Probe 1, V+
2	Liquid Level Probe 1, I+
3	Liquid Level Probe 1, V-
4	Liquid Level Probe 1, I-
5	Liquid Level Probe 2, V+
6	Liquid Level Probe 2, I+
7	Liquid Level Probe 2, V-
8	Liquid Level Probe 2, I-
9	Cernox 1 +
10	Cernox 1 -
11	Cernox 2 +
12	Cernox 2 -
13	Heater +
14	Heater -1
15	N.C.
16	N.C.
17	N.C.
18	N.C.
19	N.C.
20	N.C.
21	N.C.
22	N.C.
23	N.C.
24	N.C.
25	N.C.
26	N.C.
27	N.C.
28	N.C.

29	N.C.
30	N.C.
31	N.C.
32	N.C.

**Table 6.4: Helium cooldown valve control interfaces. Each cooldown valve will have a Bimba actuator attached to it.**

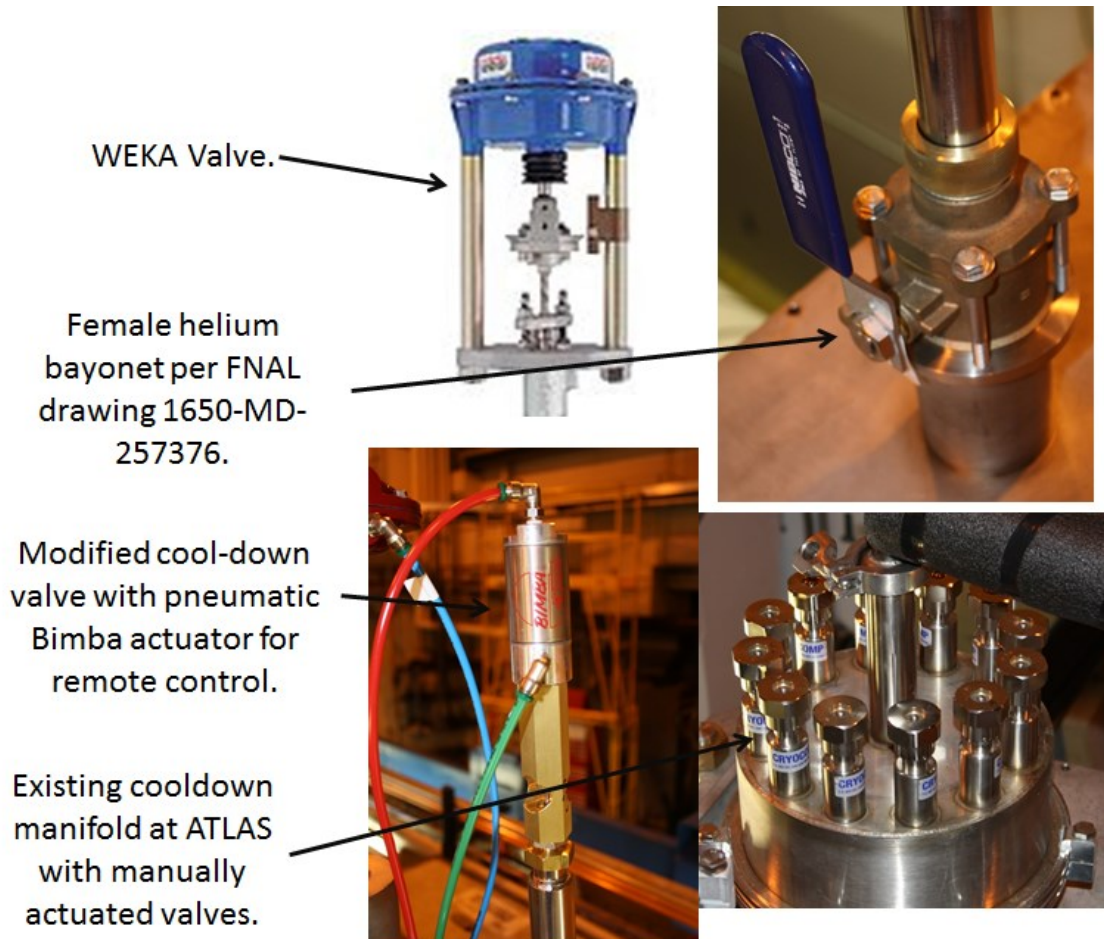
Item	Use	Connection
1	Electrical	Amphenol MS3101A-14S-6P
2	Pneumatic	¼" NPT

**Table 6.5: Helium system WEKA valve uses.**

Item	Use
1	J-T Valve
2	J-T Bypass Valve
3	5K Coupler Intercepts
4	5K Valve Intercepts
5	70K Slow Tuner Heat Exchanger
6	70K Valve Intercepts
7	70K Coupler Intercepts
8	70K Heat Shield

**Table 6.6: WEKA valve control interfaces.**

Item	Use	Connection
1	0-100% Open Control Signal	5-20mA Signal, Amphenol MS3101A-14S-6P Connector.
2	Pneumatic	¼" NPT
3	Electrical	+24 VDC

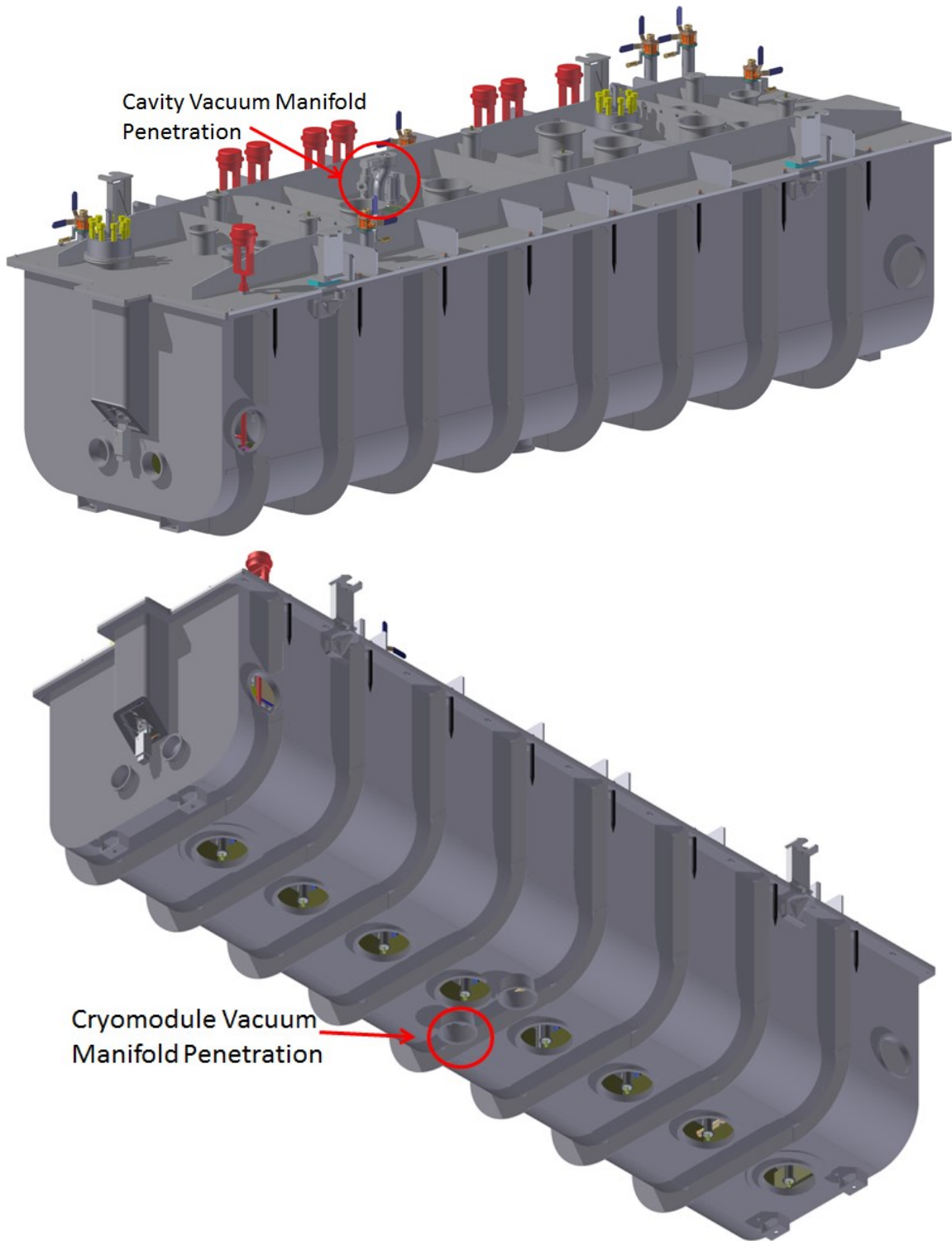


**Figure 6.3: Cryogenic valve and bayonet interface examples.** Top left, a WEKA valve actuator similar to what will be used on the HWR cryomodule, Top right, a female helium bayonet input. Bottom left, A Bimba actuator similar to what will be used on the HWR cryomodule. Bottom right, cooldown manifold with manually actuator cryogenic valves for a cryomodule in ATLAS; these valves will be modified with a Bimba actuator to provide remote control for the HWR cryomodule.

## 7. Cavity and Cryomodule Vacuum Systems.

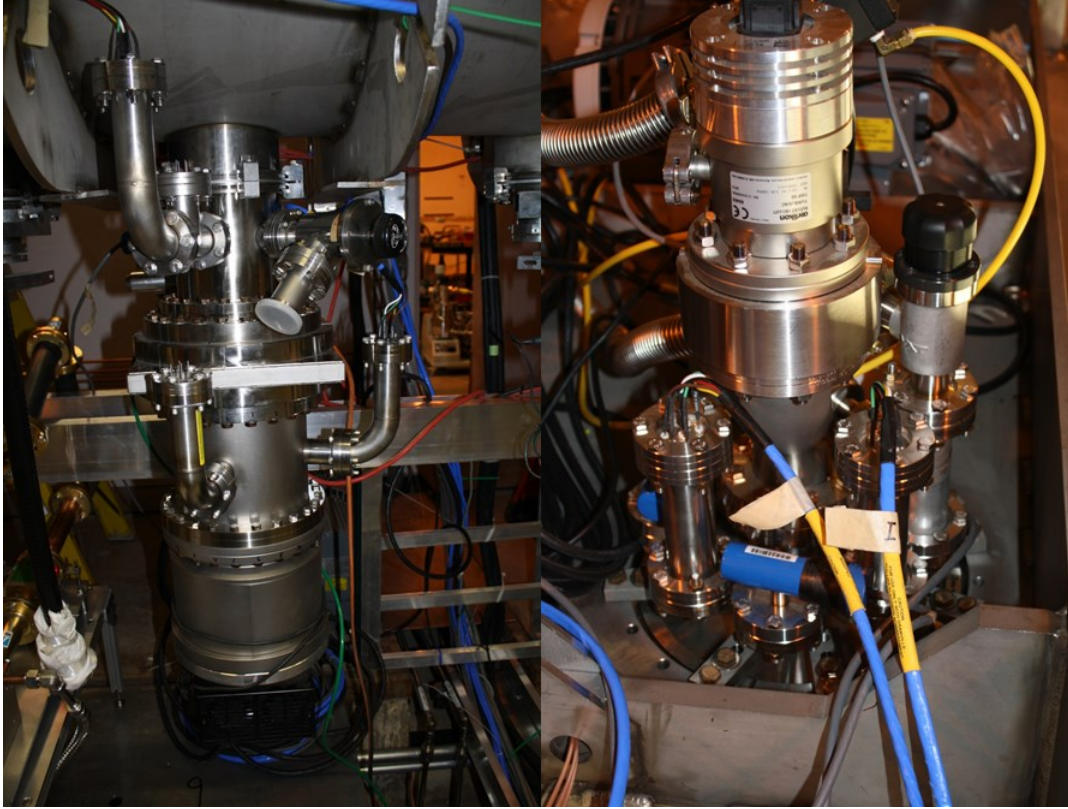
Because of the similarity between the cavity and the cryomodule vacuum systems they are described in this section together. The vacuum system penetrations will be located as shown in Figure 7.1. Figure 7.2 shows the layout of the vacuum system and the locations of the valves and gauges. The major components for the vacuum system are listed in Table 7.1 and Figure 7.3 shows similar hardware in use at ATLAS. All of the pneumatic valves will be actuated with +24VDC signals.

The cavity vacuum system will require a low-particulate up-to-air venting system for maintenance and repair activities. ANL will supply this system, see Figure 7.4 for an equivalent unit fabricated at ANL. This system will be stand alone and must be operated locally. It will require 2 20 Amp 120 VAC outlets for power. Both the cavity and cryomodule systems are compatible with remote operation.

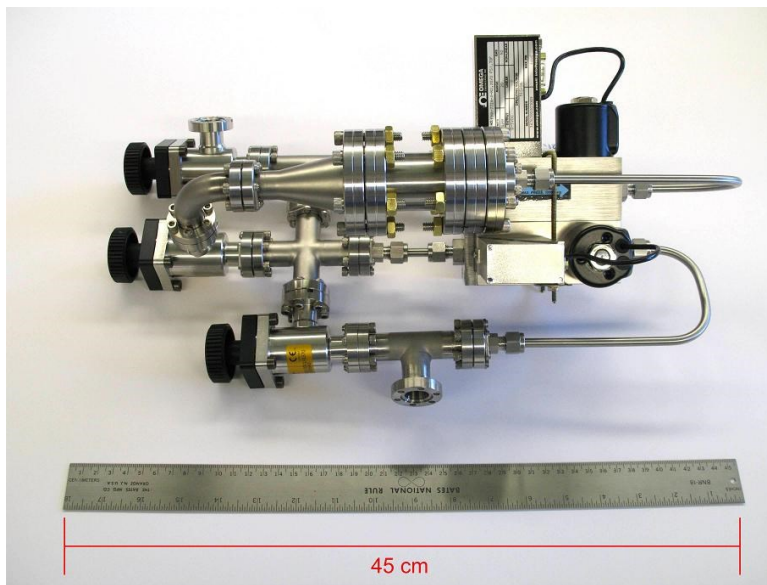


**Figure 7.1: Locations of the cavity (Top) and cryomodule (Bottom) vacuum system penetrations.**

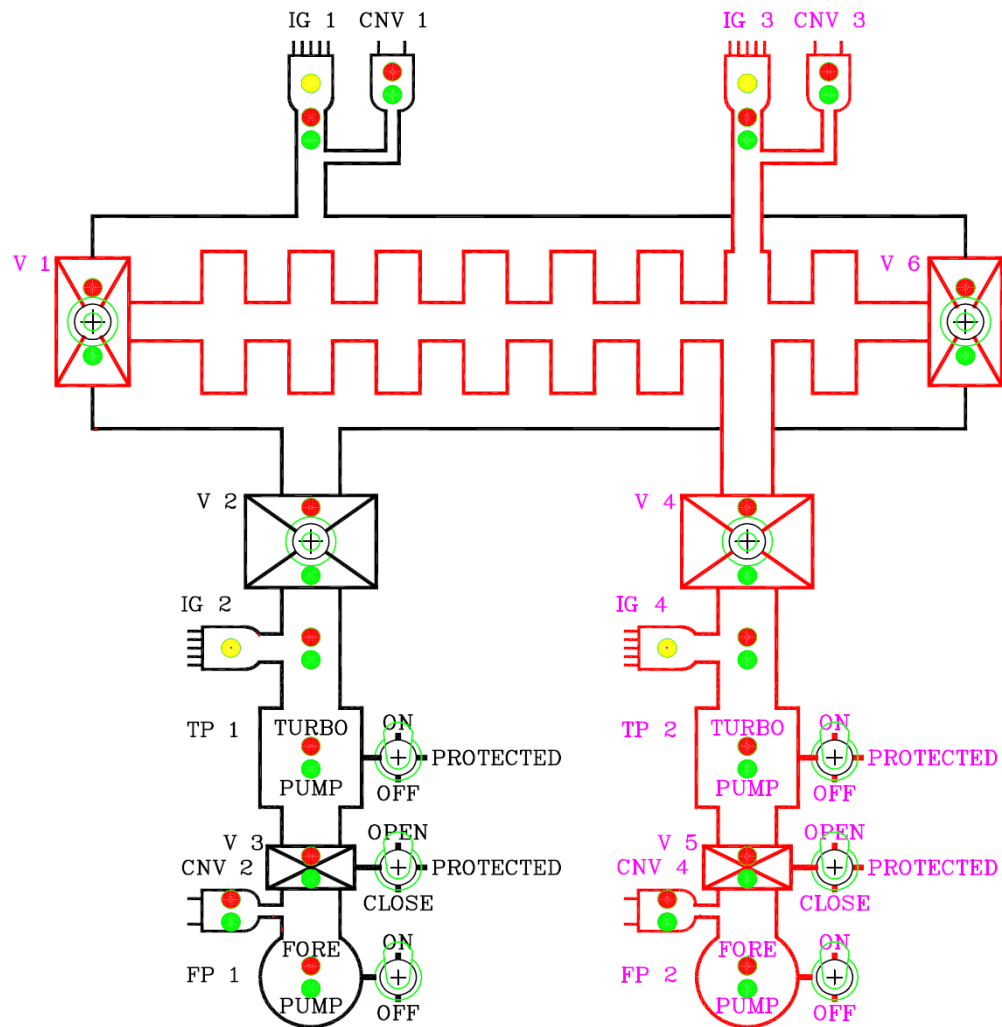




**Figure 7.3: Left, cryomodule turbo pump with gauge and gate valve assemblies installed. Right, cavity vacuum manifold. Both of these installations are on the ATLAS 72 MHz quarter-wave cryomodule and similar hardware will be used on the HWR cryomodule.**



**Figure 7.4: Up to air system. An identical system will be built and installed on the HWR cryomodule.**



**Figure 7.2: Vacuum system layout. IG/CNV and IG = high vacuum gauge, CNV = rough vacuum gauge, V = valve, TP = turbo pump, FP = forepump. Refer to table 7.1 for the vacuum system gauge part numbers and manufacturer.**

**Table 7.1: Vacuum system components.**

Item	Description	Manufacturer	P/N	Electrical Connection	Vacuum Connection	Compressed Air	Status Connection	Computer Interface
1	Cavity Manifold Gate Valve	VAT	20336-CE44	Amphenol MS3101A-14S-6P	4.5" CF, M8-1.0	Female 1/4" NPT	Amphenol MS3101A-14S-6P	N/A
2	Cryomodule Gate Valve	VAT	10846-UE44	Amphenol MS3101A-14S-6P	DN200 CF	Female 1/4" NPT	Amphenol MS3101A-14S-6P	N/A
3	Cavity Foreline Valve	VAT	26424-KE41	Amphenol MS3101A-14S-6P	DN16 ISO-KF	Female 1/4" NPT	Amphenol MS3101A-14S-6P	N/A
4	Cryomodule Foreline Valve	VAT	24432-KE41	Amphenol MS3101A-14S-6P	DN40 ISO-KF	Female 1/4" NPT	Amphenol MS3101A-14S-6P	N/A
5	Cavity Turbo Pump	Oerlikon/Leybold	85402	N/A	DN63 CF	N/A	N/A	N/A
6	Cavity Turbo Controller, NT 10	Oerlikon/Leybold	85901	120 VAC 3-Prong Plug	N/A	N/A	N/A	10 Terminal Screw Strip
7	Cryomodule Turbo Pump	Oerlikon/Leybold	11764	N/A	DN200 CF	N/A	N/A	N/A
8	Cryomodule Turbo Controller, TD 20	Oerlikon/Leybold	800075V0004	120 VAC 3-Prong Plug	N/A	N/A	25 Pin D-Sub	RS-484, 9-way PLC Interface
9	Cavity Foreline Pump	Oerlikon/Leybold	133100	120 VAC 3-Prong Plug	DN16 ISO-KF	N/A	N/A	N/A
10	Cryomodule Foreline Pump	Oerlikon/Leybold	133102	120 VAC 3-Prong Plug	DN40 ISO-KF	N/A	N/A	N/A
11	Cavity Foreline Gauge	MKS-HPS Products	103170024SH	N/A	2.75" CF	N/A	N/A	N/A
12	Cryomodule Foreline Gauge	MKS-HPS Products	103170024SH	N/A	2.75" CF	N/A	N/A	N/A

**Table 7.1: Vacuum system components, continued**

Item	Description	Manufacturer	P/N	Electrical Connection	Vacuum Connection	Compressed Air	Status Connection	Computer Interface
13	Cavity High-Vacuum Gauge	MKS-HPS Products	104220008	N/A	2.75" CF	N/A	N/A	N/A
14	Cavity Rough-Vacuum Gauge	MKS-HPS Products	103170024SH	N/A	2.75" CF	N/A	N/A	N/A
15	Cryomodule High-Vacuum Gauge	MKS-HPS Products	104220008	N/A	2.75" CF	N/A	N/A	N/A
16	Cryomodule Rough-Vacuum Gauge	MKS-HPS Products	103170024SH	N/A	2.75" CF	N/A	N/A	N/A
17	Cavity Vacuum Gauge Controller	MKS-HPS Products	937B-US-CCCCCT-NA	120 VAC 3-Prong Plug	N/A	N/A	25 Pin D-Sub	RS-232/485
18	Cryomodule Vacuum Gauge Controller	MKS-HPS Products	937B-US-CCCCCT-NA	120 VAC 3-Prong Plug	N/A	N/A	25 Pin D-Sub	RS-232/485

**Table 7.2: Connectors and wiring for the vacuum system components listed in table 7.1.**

NT 10 Interface		NT 20 Interface Connection		MKS 937B Relay Output	
Pin	Connection	Pin	Connection	Pin	Lead
1	Start	1	Remote (Input)	1	Relay 1 N.O.
2	Stop # 1	2	Start[H] (Input)	2	Relay 1 COM.
3	Stop # 2	3	Stop[L] (Input)	3	Relay 2 N.O.
4		4	Control GND	4	Relay 2 COM.
5	Normal Operation N.C.	5	Supply GND	5	Relay 3 N.O.
6	Normal Operation Com.	6	24 VDC, Max 80 mA	6	Relay 3 COM.
7	Normal Operation N.O.	7		7	Relay 4 N.O.
8		8	Error (Relay) N.O.	8	Relay 4 COM.
9	Failure/Forepump Pres. #1	9	Error (Relay) COM.	9	Relay 5 N.O.
10	Failure/Forepump Pres. #2	10	Normal (Relay) N.O.	10	Relay 5 COM.
<b>Amphenol MS3101A-14S-6P</b>		11	Normal (Relay) COM.	11	Relay 6 N.O.
<b>Pin</b>	<b>Lead</b>	12	Pump Rotates (Relay) N.O.	12	Relay 6 COM.
A	Open	13	Pump Rotates (Relay) COM.	13	
B	Open Common	14		14	Relay 7 N.O.
C	Not Connected	15		15	Relay 7 COM.
D	Not Connected	16	Acceleration (Relay) COM.	16	Relay 8 N.O.
E	Closed Common	17		17	Relay 8 COM.
F	Closed	18	Option Relay 3 N.O.	18	Relay 9 N.O.
Free Wire	Ground	19	Option Relay 3 COM.	19	Relay 9 COM.
		20	Option Relay 3 N.C.	20	Relay 10 N.O.
		21	Error (Relay) N.C.	21	Relay 10 COM.
		22	Option 3 (Input)	22	Relay 11 N.O.
		23	Acceleration (Relay) N.O.	23	Relay 11 COM.
		24		24	Relay 12 N.O.
		25		25	Relay 12 COM.

## 8. RF System Connections

The RF connections for the cryomodule fall into two categories. (1) The connections for the RF power couplers and the connections for the RF pick-up probes (transmitted power probes). (2) The connections for the support systems: compressed dry air to prevent condensation and electrical connections for operating and monitoring the coupler variable position drive. Table 8.1 summarizes the connections to be used for the RF connections. Each cavity will have one EIA 2” RF power connection, adapted to 1-5/8” external to the cryomodule, and two type-N connections (for redundant pick-up probes) located external to the cryomodule. The locations of the penetrations are shown in Figure 8.1. Table 8.2 lists the compressed dry air requirements, Table 8.3 describes the power coupler linear actuator stepping motor connector and Table 8.4 describes the power coupler linear actuator position indicator connector. Please note, it is assumed here that the clean dry air will be vented to the tunnel in operation. Figure 8.2 shows similar hardware installed on the ATLAS 72 MHz quarter-wave cavity cryomodule.

**Table 8.1: Summary of the RF Connections for the cryomodule.**

Cavity	Connection
1 - Coupler	EIA 1-5/8”
1 – Pick-Ups	QTY = 2 Type-N
2 - Coupler	EIA 1-5/8”
2 – Pick-Ups	QTY = 2 Type-N
3 - Coupler	EIA 1-5/8”
3 – Pick-Ups	QTY = 2 Type-N
4 - Coupler	EIA 1-5/8”
4 – Pick-Ups	QTY = 2 Type-N
5 - Coupler	EIA 1-5/8”
5 – Pick-Ups	QTY = 2 Type-N
6 - Coupler	EIA 1-5/8”
6 – Pick-Ups	QTY = 2 Type-N
7 - Coupler	EIA 1-5/8”
7 – Pick-Ups	QTY = 2 Type-N
8 - Coupler	EIA 1-5/8”
8 – Pick-Ups	QTY = 2 Type-N

**Table 8.2: Compressed dry air requirements. The system will include air desiccators which will need maintenance on 6-12 month schedule in addition to the humidity requirement listed below.**

Item	Specification
Supply Connection	4-VCR
Pressure	80-120 PSIG
Max Flow	1,000 SCFH
Particulate Filtering	<5 µm
Dew Point	<-40 <sup>0</sup> F
Hydrocarbon Content	<0.003 ppmw

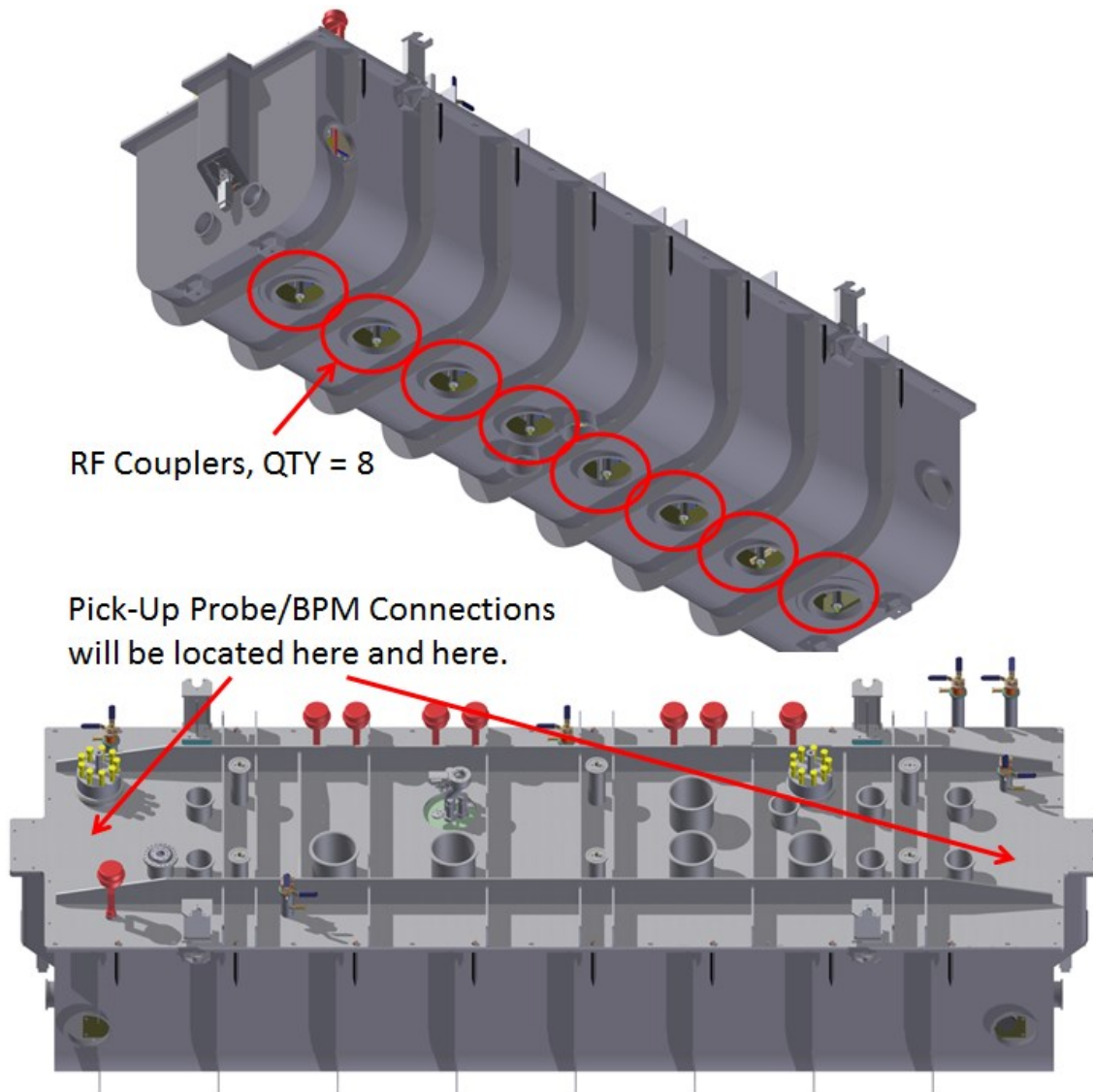


Figure 8.1: Locations for the RF connections. Top, the RF power couplers. Bottom, the RF pick-up probes.

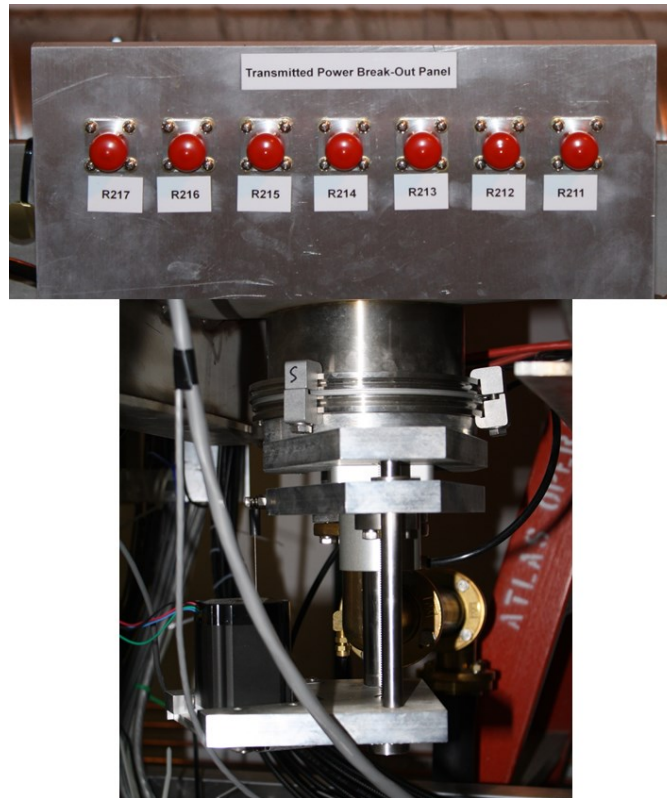
Table 8.3: Power coupler linear actuator stepping motor Amphenol MS3101A-14S-6P connector pin connections. This will be a Bipolar Lin Engineering 5718L-01 stepping motor (2.0A per phase) or equivalent.

Pin #	Connection
A	Phase $A$
B	Phase $\bar{A}$
C	Phase $A$
D	Phase $B$
E	Phase $\bar{B}$
F	Phase $B$
Free Wire	GND



**Table 8.4: Power coupler linear actuator position indicator pin connections. The position indicator is a 10 k $\Omega$  potentiometer with three leads.**

Pin #	Connection
1	Input + (25 V max)
2	Output +, Variable
3	Common
4	Not Used
5	Cable GND



**Figure 8.2: Top, RF connector panel for the 7 quarter-wave cavities in a cryomodule at ATLAS. Bottom, RF power coupler port on the 72 MHz quarter-wave cavity cryomodule in ATLAS. The linear actuator with stepping motor and linear position indicator is installed.**

## 9. Slow Tuner Connections.

The slow tuners are pneumatically controlled. The cryomodule will be delivered with the controller, which will require a -10 to +10 V frequency error signal, to control the slow tuner pneumatics for each cavity. The pneumatics require two regulated room temperature (293 K) helium gas supplies to be provided by Fermilab: one at 0.25 PSIG and one at 60 PSIG. The helium gas purity/cleanliness must be equivalent to the gas input to the helium refrigeration system. Table 9.1 lists the pneumatic connections and Table 9.2 lists the frequency error connector wiring. Figure 9.1 shows the feedthroughs and control pots installed on the 72 MHz quarter-wave cavity cryomodule at ATLAS.

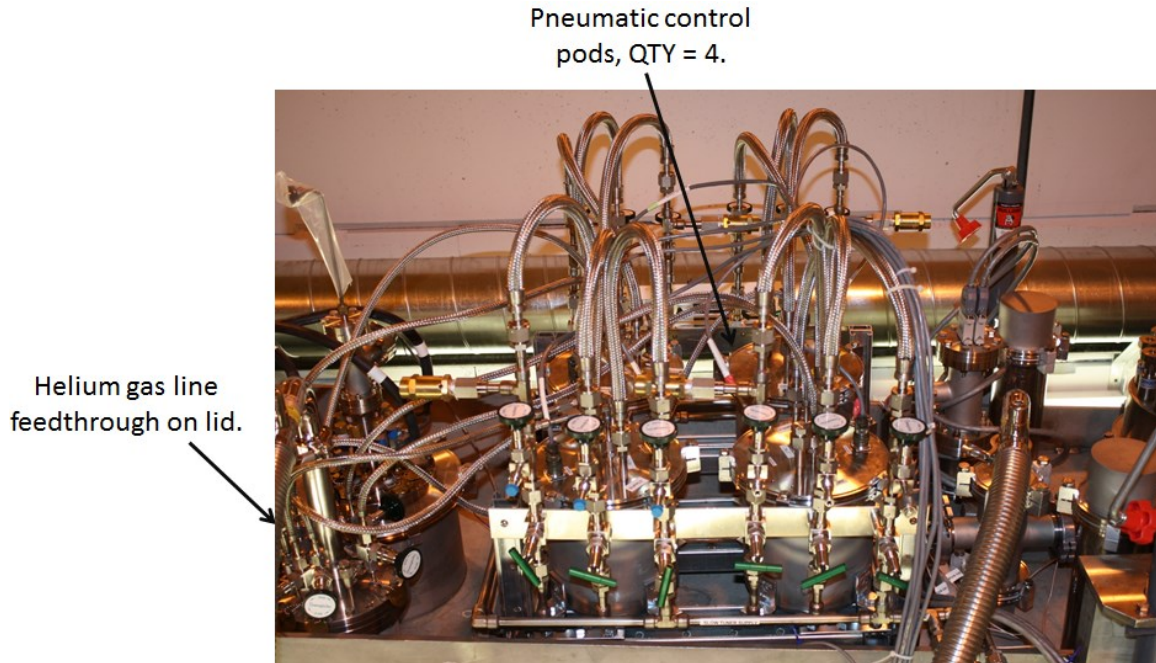
Between the controller and the pneumatics for each cavity cables will have to be run for the pressure transducers and solenoid valves. Argonne will supply these cables but needs to be told the length to procure. The length should extend from the center of the cryomodule to the relay-rack in which the controller will be installed.

**Table 9.1: Pneumatic connections for the slow tuner.**

Supply	Connection
0.25 PSIG	4-VCR
60 PSIG	4-VCR

**Table 9.2: Frequency error electrical connections and status monitors. A female dB-25 connector will be available for this connection.**

Pin	Connection
1	Not Used
2	Cavity 1, -10 to +10 V
3	Cavity 2, -10 to +10 V
4	Cavity 3, -10 to +10 V
5	Cavity 4, -10 to +10 V
6	Not Used
7	Not Used
8	Not Used
9	Cavity 1, Status
10	Cavity 2, Status
11	Cavity 3, Status
12	Cavity 4, Status
13	Not Used
14	Cavity 5, -10 to +10 V
15	Cavity 6, -10 to +10 V
16	Cavity 7, -10 to +10 V
17	Cavity 8, -10 to + 10 V
18	Not Used
19	Not Used
20	Not Used
21	Not Used
22	Cavity 5, Status
23	Cavity 6, Status
24	Cavity 7, Status
25	Cavity 8, Status



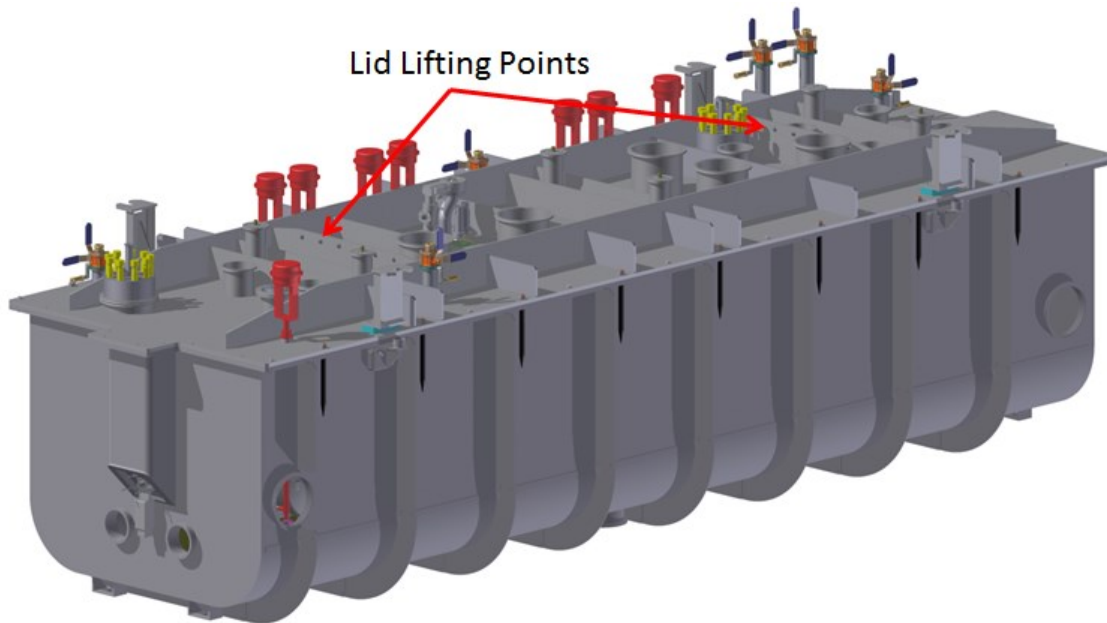
**Figure 9.1: Slow tuner control pots (QTY = 4) and helium gas line feedthroughs on the 72 MHz quarter-wave cavity cryomodule installed in ATLAS.**

## **10. BPM Connections.**

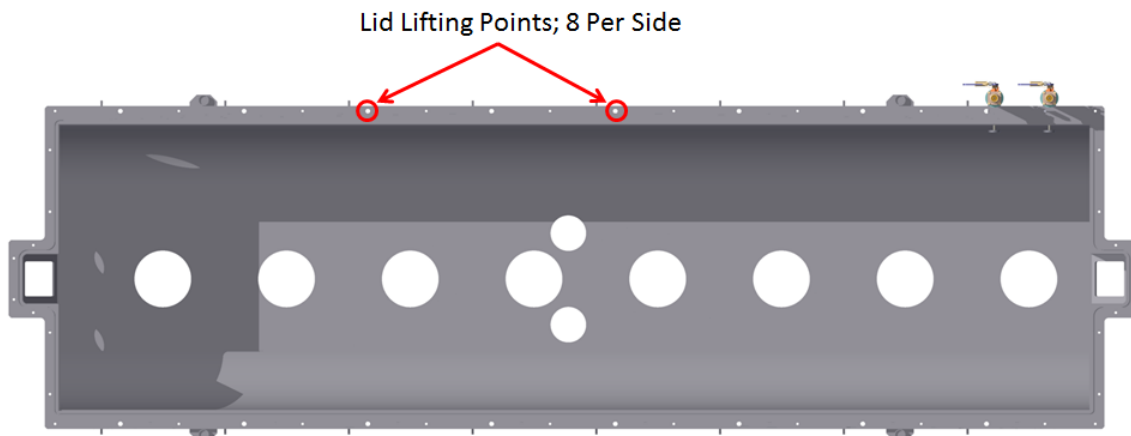
The 32 BPM RF connections will be available on a break-out panel located on the lid of the cryomodule. Argonne will supply this break-out panel and will have one type-N jack per BPM connection available. This breakout panel will be located with the cavity RF Pick-Up Connections shown in Figure 8.1 and similar to what is shown in Figure 8.2 (Top). FNAL may bypass the break-out panel and connect directly to the electrical feedthrough. However, this is not recommended.

## **11. Lifting Attachment Points.**

On the lid of the cryomodule there are two gussets with 1-1/8" clearance holes for lifting. These gussets are engineered to safely lift the lid with the cold mass hanging from it and to lift the entire assembly (box+lid). Figure 11.1 shows the locations of these gussets. The box may be lifted using the 1" diameter holes located in the lip, shown in Figure 11.2, these points may also be used to lift the entire cryomodule assembly.



**Figure 11.1: Locations for lifting from the lid. The gussets are located 123.7" apart and each gusset has 6, 1-1/8" clearance holes, spaced on 5" centers for lifting. These gusset are engineered to support the weight of the entire cryomodule assembly.**

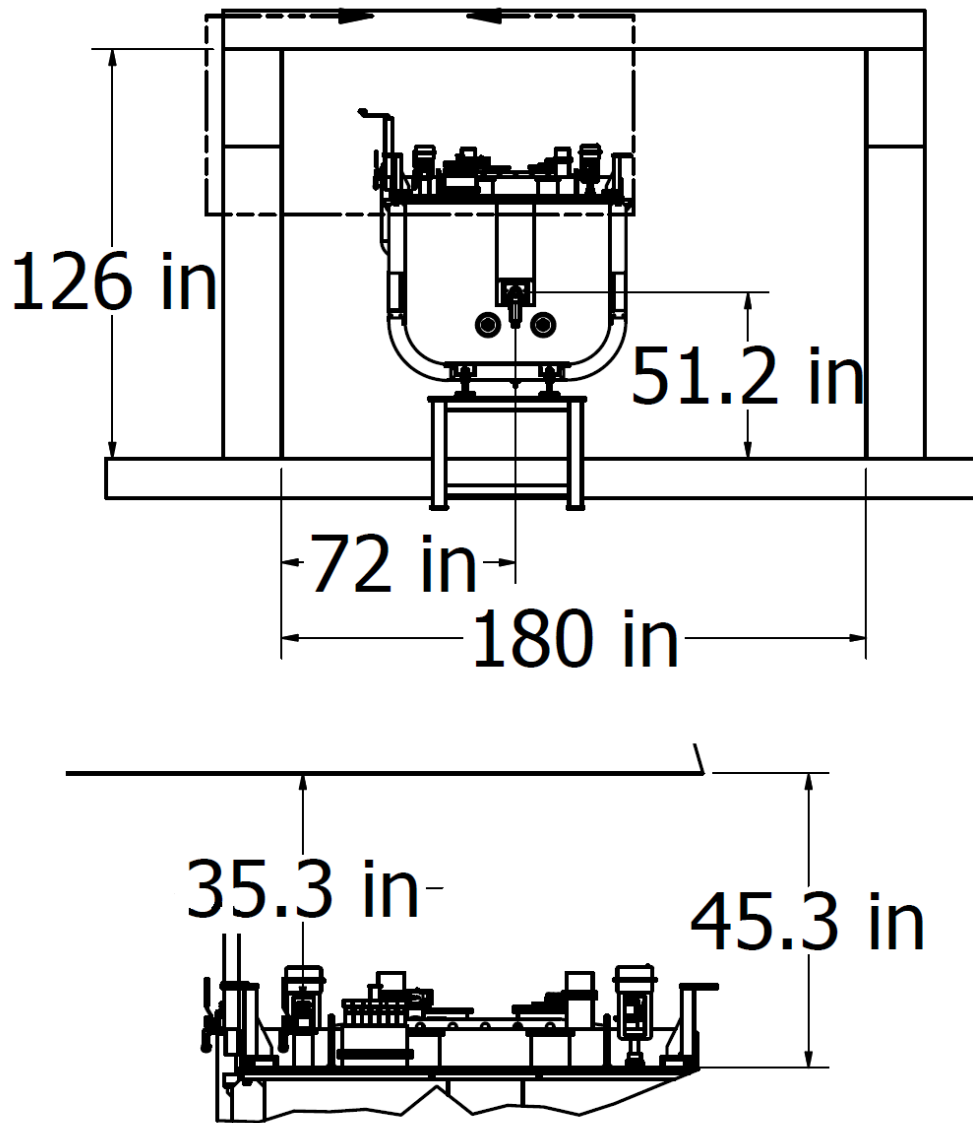


**Figure 11.2: Locations for lifting the box. Each side of the box has 8, 1" diameter, clearance holes for lifting.**

## 12. Cryomodule Location and Required Clearance.

In this section we review the proposed tunnel size and how the cryomodule fits into this space. The cryomodule occupies a space of 79" x 75" x 246" (2 m x 2 m x 6.2 m; width x height x length) with no bayonets installed. The tunnel dimensions are proposed to be 15' x 10' 6" (width x height), see Figure 12.1. The cryomodule will be aligned with the beam-axis positioned at 51.181" (1.3 meters) above the floor and 72" away from the wall, see Figure 12.1. With a beam-line height of 51.181" there will nominally be 24" of space underneath the cryomodule. All of this space will be used for the RF coupler drive assemblies and vacuum systems. Above the cryomodule from the lid to the ceiling there will be 45" and from the top of the standard bayonet (FNAL drawing number 1650-MD-

257376) there is 35" to the ceiling which does not leave enough room for the installation or removal of the helium bayonets. The sub-atmospheric output bayonet will be built according to JLAB drawing number 75300-E-0034. The top of this female bayonet will sit 10-12" above the lid of the cryomodule. It is important to note that both the cryomodule and cavity vacuum system forepumps will have to be located on the floor next to the cryomodule or on a mezzanine mounted on the accelerator wall. Each of these pumps requires 24" x 36" of floor space and stands 24" high.



**Figure 12.1: Minimum required size of the PXIE and PIP-II tunnels and close-up of the space between the top of the cryomodule and the ceiling.**