



Fermi National Accelerator Laboratory
P.O. Box 500 - Batavia, Illinois - 60510

Fermilab Interface Control Document
INTERFACES FOR THE PIP-II SSR1 CRYOMODULE
ED0004129, Rev. -

Prepared by: D. Mitchell J. Batko C. Baffes	Organization FNAL/TD/PIP-II/Project Engineer FNAL/AD/MSD	Extension 6768 6358 4154	Date 6/10/2016
Reviewed by: M. Ball	Organization FNAL/AD/MSD/Fluids	Extension 4448	Date See Teamcenter for approval records
Reviewed by: V. Bocean	Organization FNAL/PPD/Alignment	Extension 6297	
Reviewed by: B. Chase	Organization FNAL/AD/RF/LLRF	Extension 3040	
Reviewed by: A. Chen	Organization FNAL/AD/MSD/PIP-II Vacuum	Extension 8896	
Reviewed by: J. Czajkowski	Organization FNAL/AD/MSD/Fluids	Extension 4441	
Reviewed by: S. Dixon	Organization FNAL/FESS/PIP-II conventional facilities	Extension 8501	
Reviewed by: B. Hanna	Organization FNAL/AD/PIP-II/Magnet PS	Extension 4985	
Reviewed by: J. Holzbauer	Organization FNAL/TD/Resonance Control	Extension 6820	
Reviewed by: J. Leibfritz	Organization FNAL/AD/CMTF facility	Extension 8779	
Reviewed by: A. Klebaner	Organization FNAL/AD/PIP-II cryogenics	Extension 8357	
Reviewed by: R. Pasquinelli	Organization FNAL/AD /RF/HLRF	Extension 4724	
Reviewed by: J. Patrick	Organization FNAL/AD /Accelerator Controls	Extension 2626	
Reviewed by: D. Peterson	Organization FNAL/AD /RF/HLRF		
Reviewed by: P. Prieto	Organization FNAL/AD/Interlocks	Extension 2509	
Reviewed by: V. Scarpine	Organization FNAL/AD/PIP-II instrumentation	Extension 2571	
Reviewed by: J. Steimel	Organization FNAL/AD/PIP-II electrical engineering lead	Extension 4826	
Reviewed by: M. White	Organization FNAL/AD/PIP-II Injector Test cryogenics	Extension 6858	

Reviewed by: M. Chen	Organization FNAL/TD/PIP-II/SSR1 Team	Extension 4645	Date See Teamcenter for approval records
Reviewed by: S. Kazakov	Organization FNAL/TD/PIP-II/SSR1 Team	Extension 2634	
Reviewed by: T. Khabiboulline	Organization FNAL/TD/PIP-II/SSR1 Team	Extension 4693	
Reviewed by: T. Nicol	Organization FNAL/TD/PIP-II/SSR1 Team	Extension 3441	
Reviewed by: Y. Orlov	Organization FNAL/TD/PIP-II/SSR1 Team	Extension 6328	
Reviewed by: D. Passarelli	Organization FNAL/TD/PIP-II/SSR1 Team	Extension 3972	
Reviewed by: Y. Pischalnikov	Organization FNAL/TD/PIP-II/SSR1 Team	Extension 8212	
Approved by: L. Ristori	Organization FNAL/TD/PIP-II/SSR1 Lead	Extension 4401	Date See Teamcenter for approval records
Approved by: V. Lebedev	Organization FNAL/AD/PIP-II/Project Scientist	Extension 2558	
Approved by: D. Mitchell	Organization FNAL/TD/PIP-II/Project Engineer	Extension 6768	
Approved by: S. Mishra	Organization FNAL/PIP-II/IIFC	Extension 4094	
Approved by: P. Derwent	Organization FNAL/AD/PIP-II/Project Management for PIP-II Injector Test	Extension 3988	

Rev.	Date	Description	Originated By	Checked By	Approved By
-	30 DEC 2015	Initial DRAFT	<i>Don Mitchell</i>		
-	19 August 2016	Initial Release	<i>J.Batko/C.Baffes/ D.Mitchell</i>	<i>As signed</i>	<i>As signed</i>

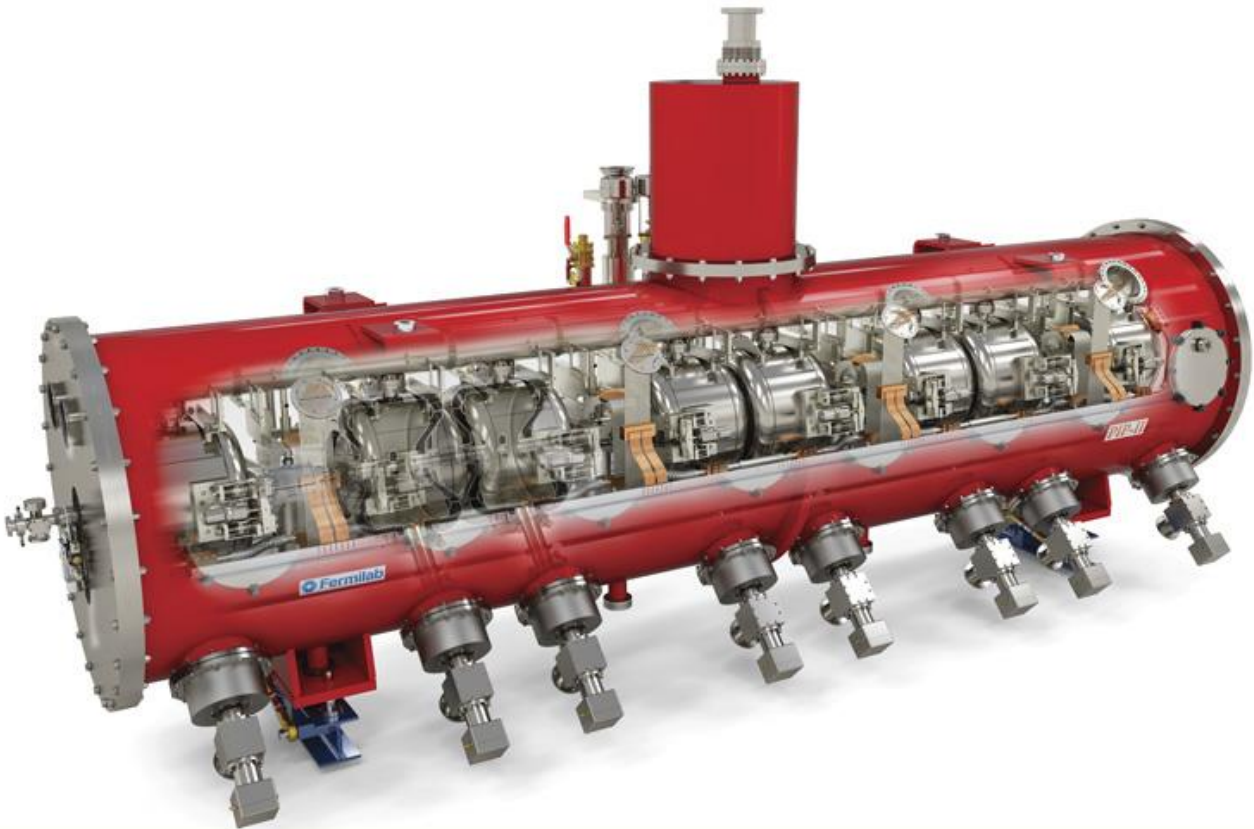

SSR1 Cryomodule for PIP-II

Technical Division



Table of Contents

1.0 Purpose-SSR1 Cryomodule	5
2.0 Beam Line Connections	6
3.0 Alignment and Stand Interface	8
4.0 Handling, Transportation, Structural Interface to Facility	10
5.0 Facility Utilities	11
6.0 Magnet Leads - Current Lead Port (CLP)	13
7.0 Magnet Power Supply	20
8.0 Coupler Port (CP) & RF Connections	21
9.0 Tuners and Tuner Access Ports (TAP)	24
10.0 Beam Position Monitors	32
11.0 Cryogenic Connections	33
12.0 Cryomodule Vacuum Systems	38
13.0 Interlocks	41
14.0 Microphonics	43
References	45
Appendix	46

A note to reviewers and approvers of Rev-

As of the revision date of this document, not enough design information is known about SSR1 and its interfacing systems to write a complete, comprehensive interface control document. As such, this revision documents what we know today, and highlights areas of uncertainty or where more design is required. The expectation is that this document will be revised when the design has progressed far enough that all interfaces may be completely specified.

1.0 Purpose-SSR1 Cryomodule

The purpose of this document is to map out the external interfaces of the SSR1, i.e. how it interfaces with the connected systems of PIP-II and the PIP-II Injector Test (formerly known as PXIE). This document endeavors to cover all connections to the SSR1 that will be made in the PIP-II Injector Test cave or PIP-II Tunnel. Figures 1.1 and 1.2 show overall views of the SSR1.

The SSR1 itself is documented in model/drawing F10002433 [1]

Critical dimensions of the SSR1 w.r.t. interfaces and installation are shown in drawing F10049253 [2].

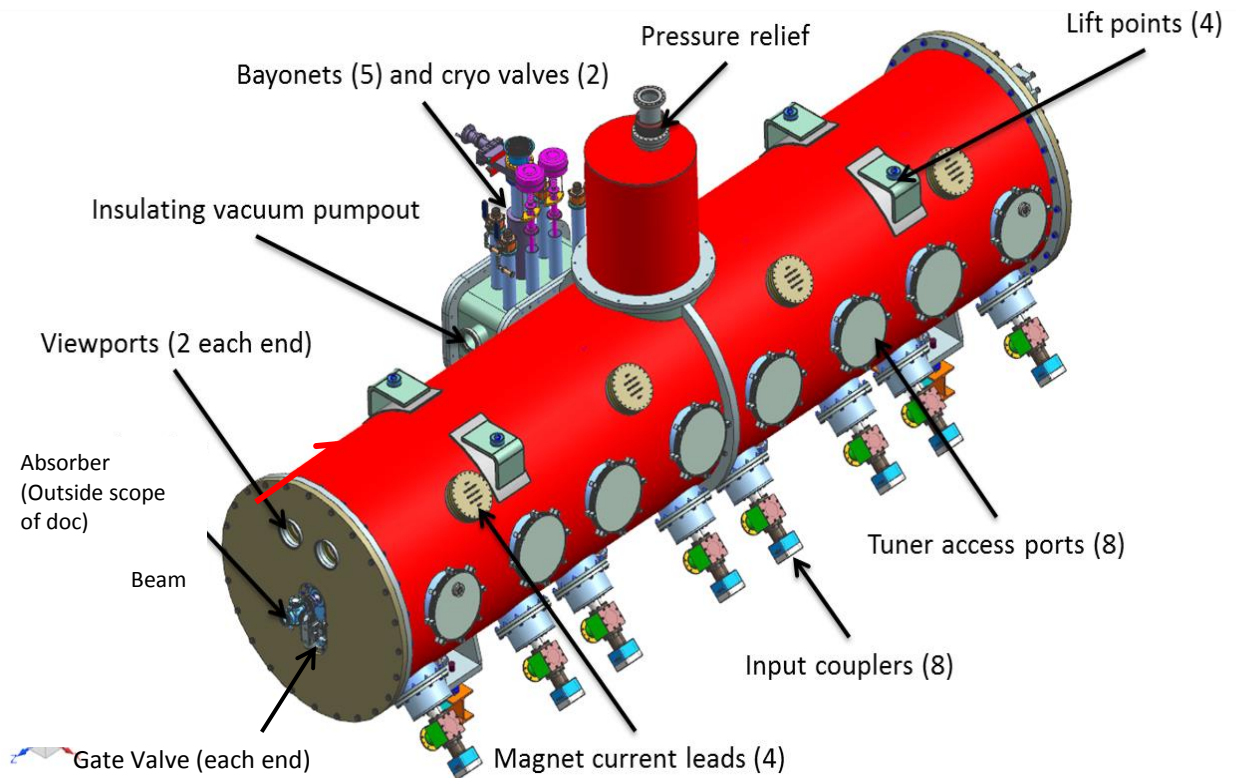

Figure 1.1: SSR1 cryomodule external features

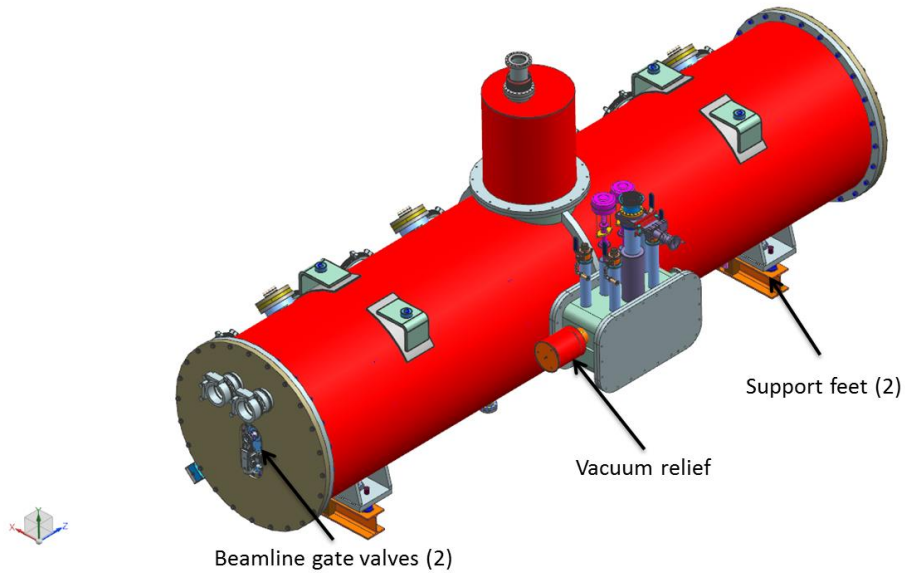

Figure 1.2: SSR1 cryomodule external features – As seen from cryo interface side

2.0 Beam Line Connections

The SSR1 provides gate valves at each end of the beamline. These valves are the only connection between adjacent cryomodules or other beamline components. Unlike systems with continuous insulating vacuums and cryogenic piping systems, (e.g. XFEL, LCLS-II), cryomodule connections in PIP-II are made to the linac infrastructure at each cryomodule.

Figure 2.1 shows the connection to the beamline. This connection is the same on each side of the cryomodule. The gate valve is a pneumatically-actuated VAT Mini UHV gate valve, series 010, model 01032-UE41. All beamline connections are via 2.75" Conflat flanges.

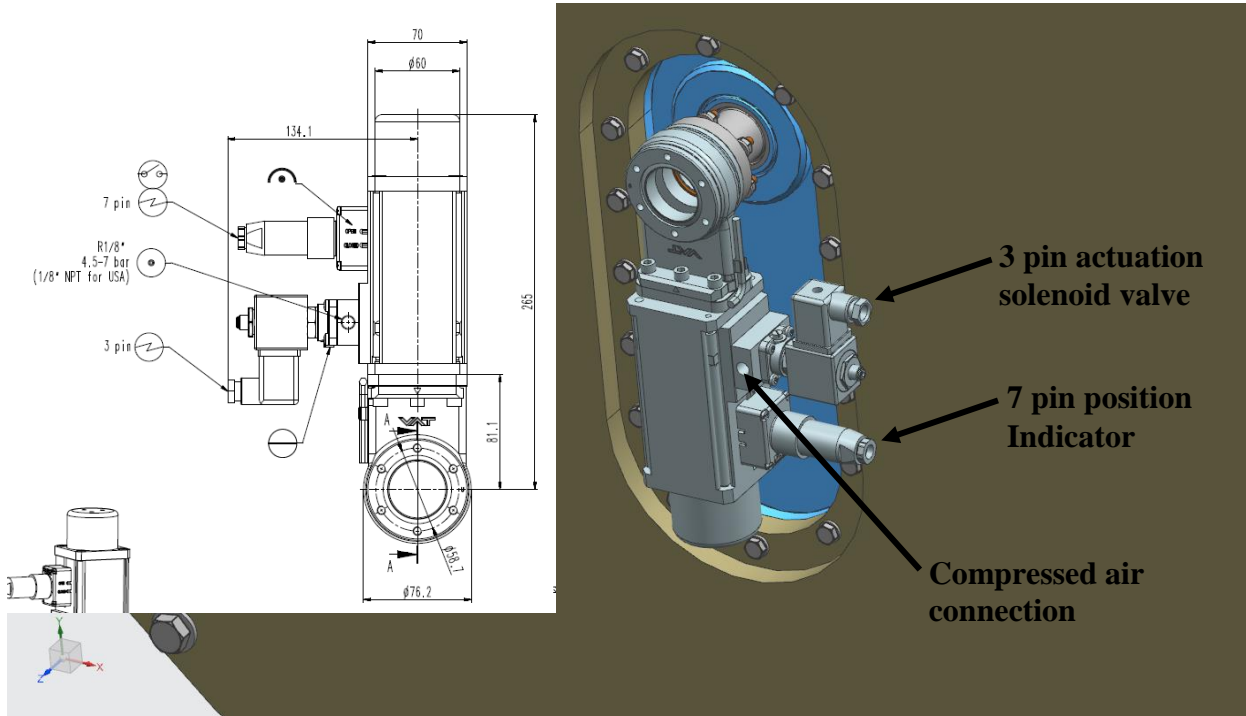

Figure 2. 1: Gate valve beam line interface

As shown in Figure 2.1, the gate valve incorporates separate controls and position indicator cables. Figure 2.2 shows the wiring diagram of both the control solenoid valve and the position indicator.

The gate valves will require compressed air supplied by AD/Fluids team as specified in section 5.

Specified solenoid voltage shall be 24VDC.

Electrical connections

Solenoid valve

Type 3/2-way
 Voltage Defined by order

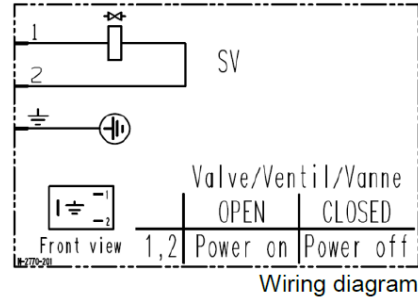

Position indicator

Type Micro switch
 Voltage ≤ 250 V AC ≤ 50 V DC
 Current max. 5.0 A 3 A

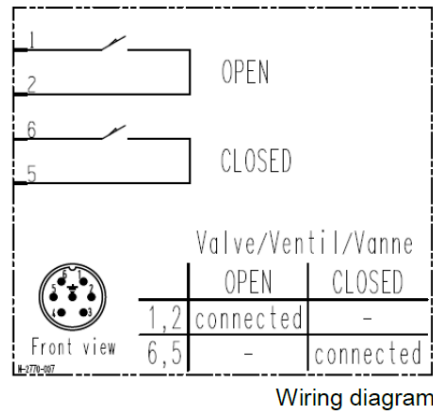

Figure 2.2: Electrical connections and wiring diagram for Gate Valve

3.0 Alignment and Stand Interface

The cryomodule will be aligned both internally and externally. There will be no need or ability to adjust the internal cavities and solenoids relative to each other after assembly. The external fiducials will be referenced to internal alignment. For internal alignment verification, two viewports will be on each external end of the vacuum chamber. Through these viewports, internal open wire targets attached to each cavity and solenoid will be visible to measure transverse shifts due to cool down.

External fiducial blocks shall be mounted on the outside of vacuum chamber of the cryomodule. These fiducial blocks will hold 1.5” SMR nests. Figure 3.1 shows the requirements and approximate locations for external fiducials on the SSR1 cryostat.

The SSR1 and PPD/Alignment teams shall provide all fiducials and referencing from external fiducials to internal cavity positions at 2K. Internal fiducials on cavities and solenoids are required to accomplish this. However, since these fiducials are not accessible in PIP-II, details of this fiducialization and alignment scheme are outside the scope of this document.

The PPD/Alignment team shall align SSR1 as a rigid body in the PIP-II Injector Test and PIP-II such that cavities and solenoids are aligned with the nominal beamline axis when the SSR1 is at 2K.

The predicted 300K → 2K shift of cavity string relative to cryostat vessel in the alignment group CSYS is

X: -0.1 mm (+X is from the beamline towards the coupler side of the cryomodule)

Z: -1.2 mm (+Z is from the beamline vertically upwards)

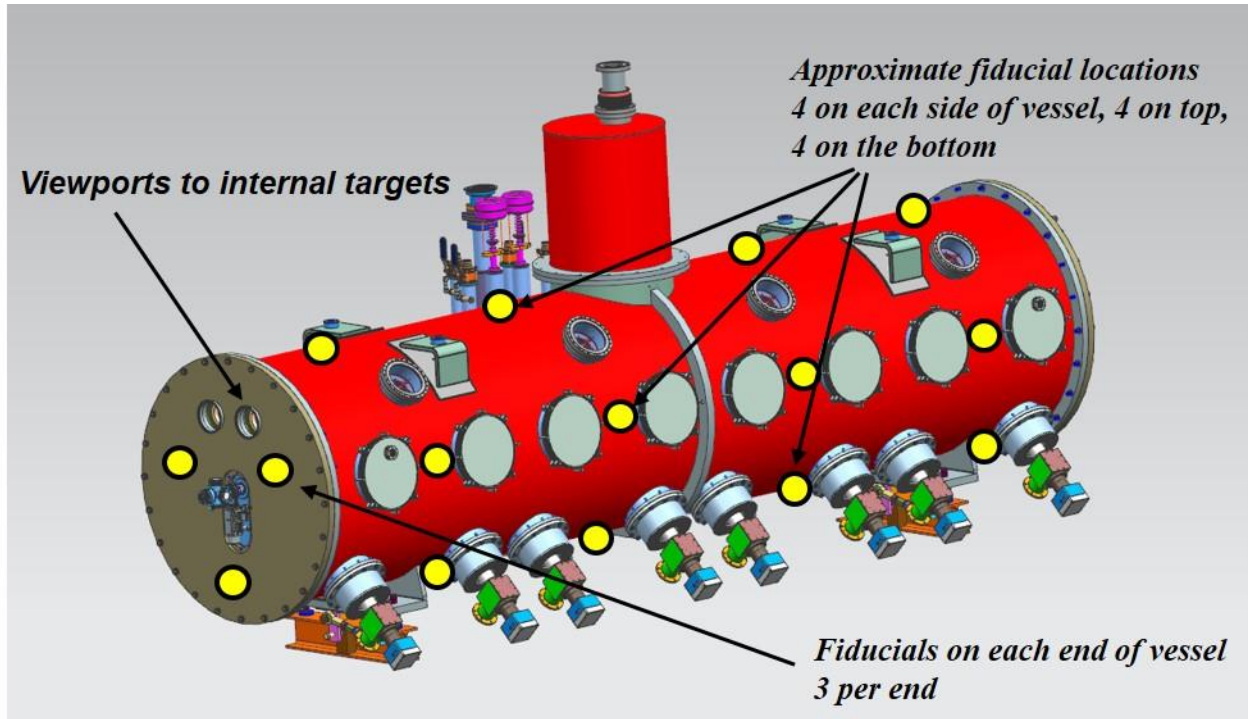

Figure 3.1: Approximate external fiducial locations. All will be tack welded to the vacuum vessel.

The alignment of SSR1 cryomodule is provided with:

- 4 vertical screw adjustors (36 mm in diameter)
- 2 transverse (left-right) adjustment turnbuckles
- 2 longitudinal adjustment screws

All of these adjusters interface to bearing pads or attachment locations on an I-beam section. The SSR1 team will provide the adjusters and I-beam section (everything shown in figure 3.2). The bottom of the I-beam section will be rigidly supported by structure provided by the AD/Mech Systems team (see section 4).

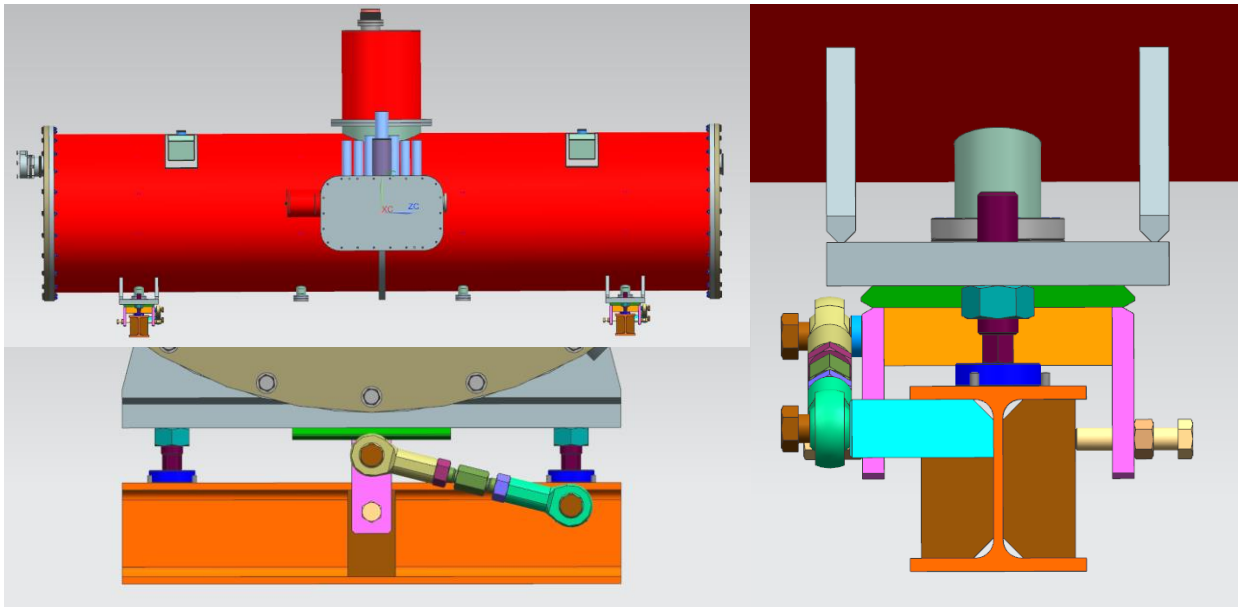

Figure 3. 2: Interface between the vacuum vessel and the supports.

4.0 Handling, Transportation, Structural Interface to Facility

The AD/Mech Systems team shall provide a support girder or surface to accommodate the structural beam of the cryomodule adjustment stage. The location of this interface plane is indicated in figure 4.1 below. The interface shall be a bolt pattern of metric bolts to be specified as part of adjustment stage design.

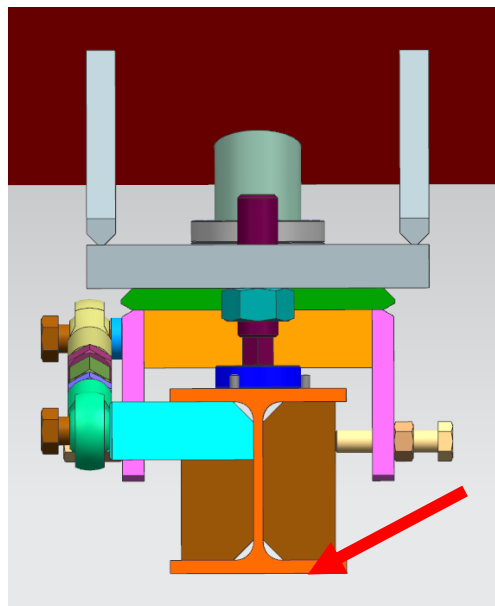

Figure 4.1: Interface plane between SSR1-provided adjustment stage and Facility-provided girder shown with red arrow

In order for cryomodules to be installed in the PIP-II tunnel, the cryomodules must reside within a specified transverse volume envelope, both while in position and during transportation down the service aisle. As such, the SSR1 cryomodule shall reside within the transverse envelope and meet all requirements defined in drawing

F10051442 [3]. Note that this drawing also defines the height of the interface between the adjustment stage and the girder.

The SSR1 team shall provide the tooling and fixturing required, if any, to transport the SSR1 cryomodule by truck to CMTF or the PIP-II facility.

The SSR1 team shall provide rigging interfaces and instructions to allow the SSR1 cryomodule to be manipulated by crane. If a below-the-hook lifting fixture is required, the SSR1 team shall provide the fixture. Hard points for the hoisting interface are shown in figure 4.2 below.

The CMTF facility provides a loading area with truck access and 24' hook height. In order to clear PIP-II Injector Test cave walls during installation, the SSR1 rigging scheme shall be designed to provide a minimum of 8.5' clearance below the SSR1 during a lift. A clearance of 11.5' would be more desirable, in that the top layer of wall blocks would not need to be removed. A clearance of 16' would be optimal, in that only roof blocks over the SSR1 location would need to be removed.

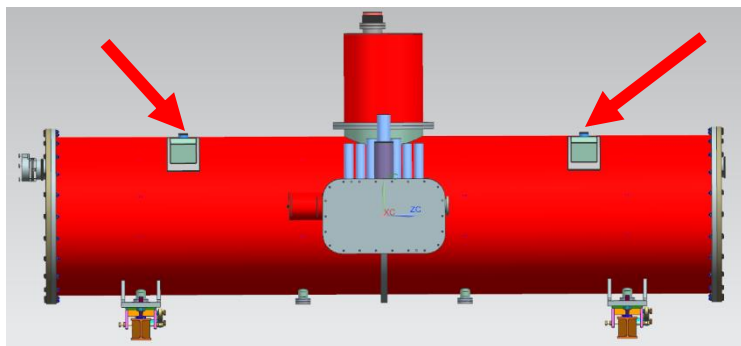

Figure 4.2: hard points for hoisting interface

The PIP-II conventional facility shall provide a loading area with truck access and hook height $\geq 20'$

The AD/Mech Systems team (TBR) shall provide a cryomodule transportation fixture for installation of SSR1 and other cryomodules in the PIP-II tunnel. This fixture may use the hoisting and/or adjustment interfaces on the cryomodule. This fixture will not be designed or used in the PIP-II Injector Test installation.

5.0 Facility Utilities

The SSR1 requires a source of clean, dry nitrogen for cryostat backfill. The AD/Fluids team shall provide nitrogen in the PIP-II Injector Test cave for this purpose. (Note: this nitrogen is NOT used for beamline vacuum backfill).

The SSR1 requires compressed air for valve operation (intermittent use). The AD/Fluids group shall provide this air, with the following parameters:

- Qty 5 valves on SSR1 (2 beamline vacuum gate valves, 1 insulating vacuum gate valve, 2 cryo valves)
- "Instrument quality" air - conditioned, dry, low-oil
- System MAWP 100psig
- System supply pressure at interface to SSR1 ≥ 80 psig
- Fitting on SSR1: **INSERT – Location TBD**

The SSR1 also requires compressed air for the coupler window and DC block (continuous use). The AD/Fluids group shall provide this air, with the following parameters:

- Coupler window
 - Conditioned air
 - Particles $\geq 5\mu\text{m}$ filtered
 - Moisture removed, dew point $\leq -10^\circ\text{C}$
 - Oil removed
 - System MAWP 50psig
 - System supply pressure at interface to SSR1 regulated
 - Adjustable 15-50psig, nominal 30psig
 - One regulator for all 8 window connections
 - Flow rate $\leq 4\text{SCFM}$ per coupler, 32SCFM total
 - Instrumentation of return air flow from each coupler required (8 return flow measurements total). SSR1 team to provide plumbing of outlet air to a single location. AD/Fluids team to provide flow measurement.
 - Inlet Fitting on SSR1: **INSERT**
 - Outlet Fitting on SSR1: **INSERT**
- DC Block
 - Conditioned air
 - Particles $\geq 5\mu\text{m}$ filtered
 - Moisture removed, dew point $\leq 5^\circ\text{C}$
 - Oil removed
 - System MAWP 50psig
 - System supply pressure at interface to SSR1 regulated
 - Adjustable 15-50psig, nominal 30psig
 - One regulator for all 8 window connection
 - Flow rate $\leq 4\text{SCFM}$ per coupler, 32SCFM total
 - Instrumentation of return air flow from each coupler required (8 return flow measurements total). SSR1 team to provide plumbing of outlet air to a single location. AD/Fluids team to provide flow measurement.
 - Fitting on SSR1: **INSERT**
 - Outlet Fitting on SSR1: **INSERT**

The SSR1 does not require water cooling for any system. (Note – RF circulators and loads provided by AD/HLRF and located below the cryomodule will require cooling. Specification of this is not within the scope of this document).

The SSR1 does not require AC power in the cave. (Note - Insulating vacuum systems will, but these are provided by AD/vacuum engineering, and specification is not within the scope of this document).

Note that the SSR1 will be sensitive to vibration induced by fluids systems. Please see microphonics requirements in section 14.

6.0 Magnet Leads - Current Lead Port (CLP)

The SSR1 cryomodule houses four superconducting magnet packages. Each of these packages consists of a solenoid coil and four coils which make horizontal and vertical correctors and a skew-quadrupole. Each magnet packages is powered by a magnet lead assembly, see Figure 6.1. The four magnet lead assemblies exit cryostat vacuum at the current lead ports, at locations shown in Figure 6.2.

The current lead ports consist of hermetic electrical feedthrus mounted on a 10" conflat flange. Each of the four current lead ports will have identical connections and wiring. Table 6.5 shows the pinout for each connection.

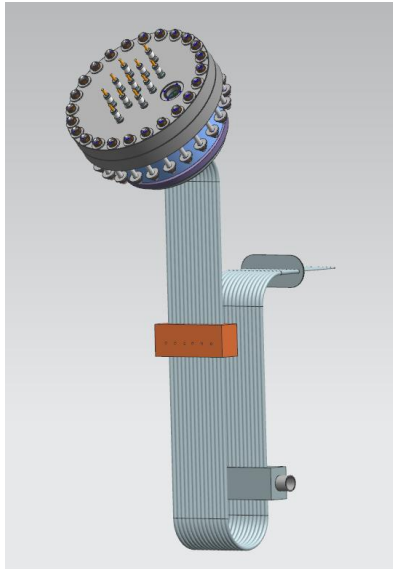

Figure 6.1: Magnet lead assembly, including internal wiring. Note – feedthru quantity and arrangement on flange does not match current design.

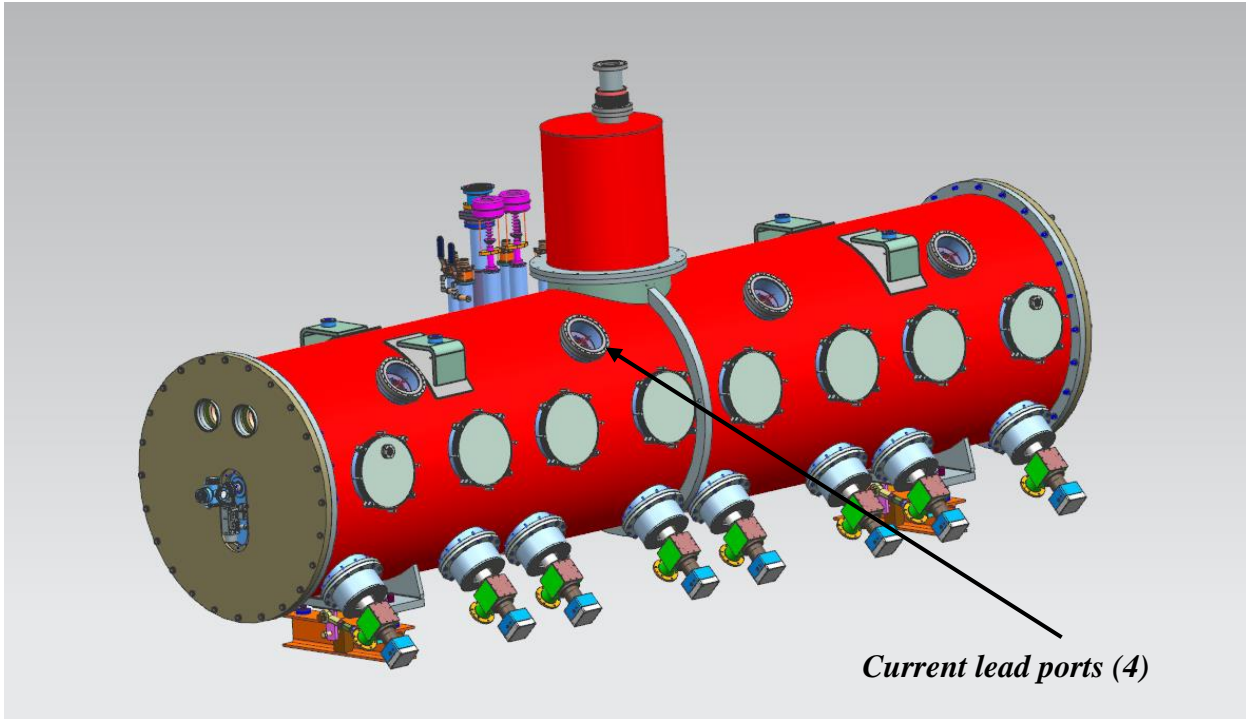

Figure 6.2: Location of current lead ports

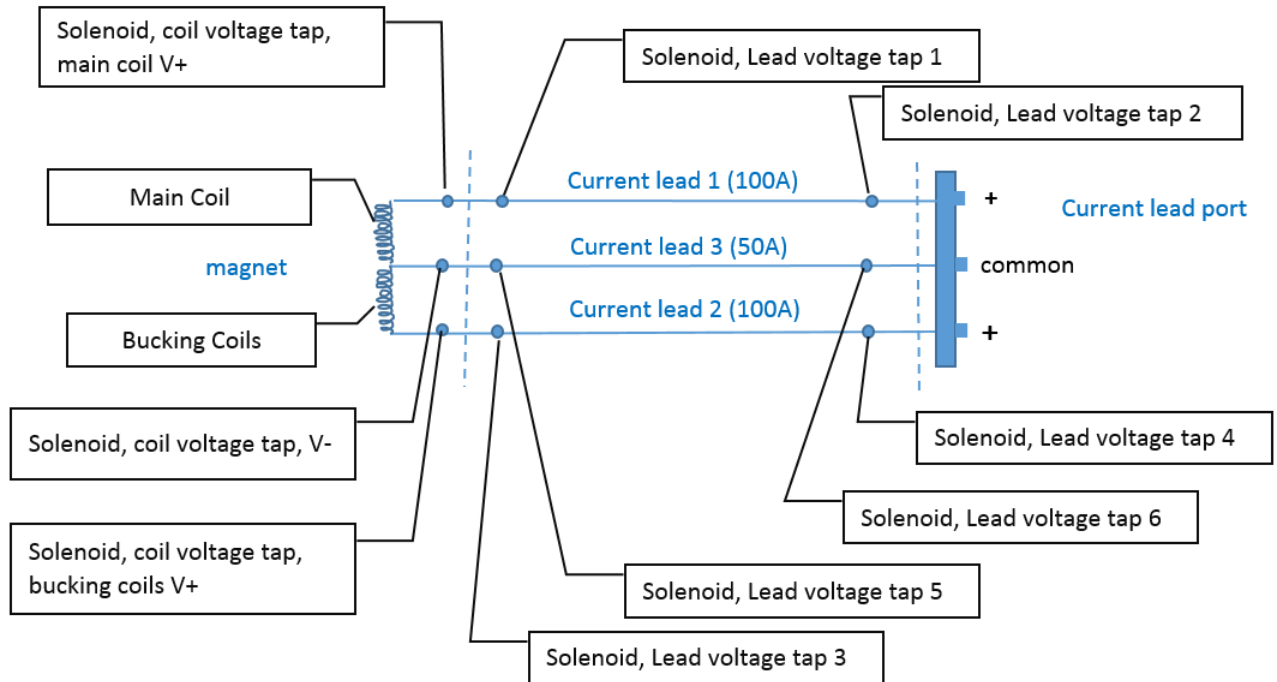

Figure 6.3: Lead identification and arrangement for solenoids

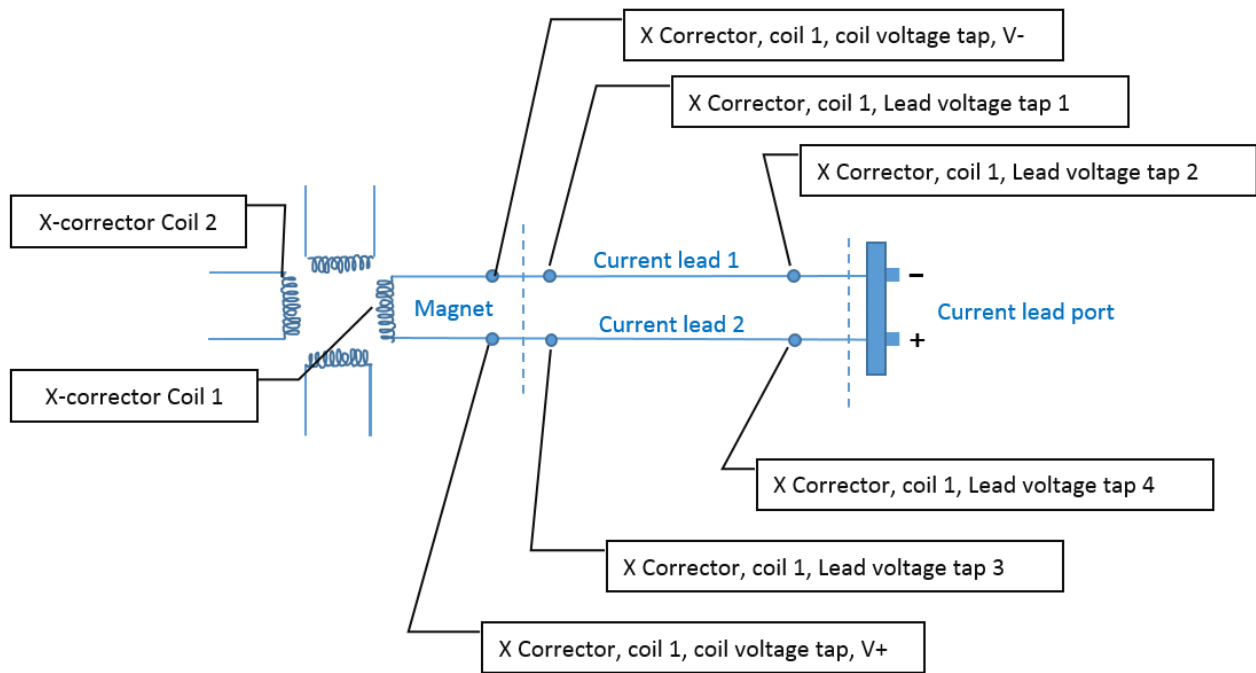

Figure 6.4: Lead identification and arrangement for corrector/skew quad

Table 6.5: Current Lead Port Pinout
 Identical for each current lead port / magnet package

Function	Current	Pinout at interface flange			
		Interface Connector Make / Model	Signal	Connector ID	Pin
X Corrector Coil 1 Power	50A	CeramTec 21032-01-W	I+	6	-
		CeramTec 21032-01-W	I-	7	-
X Corrector Coil 2 Power	50A	CeramTec 21032-01-W	I+	8	-
		CeramTec 21032-01-W	I-	9	-
Y Corrector Coil 1 Power	50A	CeramTec 21032-01-W	I+	10	-
		CeramTec 21032-01-W	I-	11	-
Y Corrector Coil 2 Power	50A	CeramTec 21032-01-W	I+	12	-
		CeramTec 21032-01-W	I-	13	-
Solenoid common (lead 3)	50A	CeramTec 21032-01-W	I	14	-
Solenoid Power (lead 1)	100A	CeramTec 21032-01-W	I	15	-
Solenoid Power (lead 2)	100A	CeramTec 21032-01-W	I	16	-
X Corrector, Coil 1, Coil Voltage Tap	0A	Detorionics DT02H-14-19PN	V+	1	TBD
X Corrector, Coil 2, Coil Voltage Tap	0A		V-		TBD
			V		TBD
Y Corrector, Coil 1, Coil Voltage Tap	0A		V-		TBD
			V		TBD
Y Corrector, Coil 2, Coil Voltage Tap	0A		V-		TBD
Solenoid coil voltage tap, main coil	0A	Detorionics DT02H-14-19PN	V	2	TBD
			V-		TBD
Solenoid coil voltage tap, bucking coil	0A		V		TBD
			V-		TBD

Table 6.5: Current Lead Port Pinout (cont.)
 Identical for each current lead port / magnet package

Function	Current	Pinout at interface flange			
		Interface Connector Make / Model	Signal	Connector ID	Pin
X corrector, coil 1, Lead voltage tap 1	0A	Detoronics DT02H-14-19PN	V	3	TBD
			ground		TBD
X corrector, coil 1, Lead voltage tap 2	0A		V		TBD
			ground		TBD
X corrector, coil 1, Lead voltage tap 3	0A		V		TBD
			ground		TBD
X corrector, coil 1, Lead voltage tap 4	0A		V		TBD
			ground		TBD
X corrector, coil 2, Lead voltage tap 1	0A		V		TBD
			ground		TBD
X corrector, coil 2, Lead voltage tap 2	0A		V		TBD
			ground		TBD
X corrector, coil 2, Lead voltage tap 3	0A		V		TBD
			ground		TBD
X corrector, coil 2, Lead voltage tap 4	0A		V		TBD
			ground		TBD

Table 6.5: Current Lead Port Pinout (cont.)
 Identical for each current lead port / magnet package

Function	Current	Pinout at interface flange			
		Interface Connector Make / Model	Signal	Connector ID	Pin
Y corrector, coil 1, Lead voltage tap 1	0A	Detronics DT02H-14-19PN	V	4	TBD
			ground		TBD
Y corrector, coil 1, Lead voltage tap 2	0A		V		TBD
			ground		TBD
Y corrector, coil 1, Lead voltage tap 3	0A		V		TBD
			ground		TBD
Y corrector, coil 1, Lead voltage tap 4	0A		V		TBD
			ground		TBD
Y corrector, coil 2, Lead voltage tap 1	0A		V		TBD
			ground		TBD
Y corrector, coil 2, Lead voltage tap 2	0A		V		TBD
			ground		TBD
Y corrector, coil 2, Lead voltage tap 3	0A		V		TBD
			ground		TBD
Y corrector, coil 2, Lead voltage tap 4	0A		V		TBD
			ground		TBD

Table 6.5: Current Lead Port Pinout (cont.)
 Identical for each current lead port / magnet package

Function	Current	Pinout at interface flange			
		Interface Connector Make / Model	Signal	Connector ID	Pin
Solenoid, lead 1, lead voltage tap 1	0A	Detoronics DT02H-14-19PN	V	5	TBD
			ground		TBD
Solenoid, lead 1, lead voltage tap 2	0A		V		TBD
			ground		TBD
Solenoid, lead 2, lead voltage tap 3	0A		V		TBD
			ground		TBD
Solenoid, lead 2, lead voltage tap 4	0A		V		TBD
			ground		TBD
Solenoid, lead 3, lead voltage tap 5	0A		V		TBD
			ground		TBD
Solenoid, lead 3, lead voltage tap 6	0A		V		TBD
			ground		TBD

7.0 Magnet Power Supply

This section will document the DC power supply needs for SSR1 at PIP-II Injector Test. There are power supplies for four solenoids as well as X and Y corrector coils located at each solenoid.

The AD EE-Support group will design and build the power supplies.

The following table specifies the magnets and power supply requirements:

Table 7.1 power supply requirements

Parameter	Solenoid coil	Corrector single coil
SSR1 Coil inductance	3.28 H	~.10 H
Type of source	Bipolar	Bipolar
Power supply max operating current	70 A	50 A
DC Bulk Voltage	22V	22V
# of SSR1 Supplies	4	16
Maximum speed of current ramp	1.5 A/sec	25 A/sec
Cable Type	#4	#4
Cable Length	400 ft	400 ft
Cable resistance	.1076 ohms	.1076 ohms
Accuracy of current setting	<1%	<1%
Current ripple	<0.1%	<0.1%
Quench current	90 A	>50A

The plan is to use a system similar to that used for the HWR. The power supply system will consist of a bulk supply that will operate at 22 volts, four 70 amp switching modules for the solenoids and sixteen 50 amp switching modules for the correctors. The nominal operating current for the solenoids from an analysis by V. Lebedev is 46 amps. The relay rack AC power will include 120 VAC to each rack and a 480 VAC disconnect for the bulk supply. These relay racks will be placed in the mezzanine at CMTF. Each corrector package consists of four individual coils. Each coil can be individually powered to provide both a horizontal and vertical dipole field as well as a quadrupole field depending on the ratio of currents from each power supply. For quench protection, we will measure the coil voltage using voltage taps at the cryostat and subtract from that a $L \cdot \frac{dl}{dt}$ term (where we use a transducer to measure $\frac{dl}{dt}$) and set a threshold of 1 volt for a quench.

The power supplies and their control system shall be able to provide a degaussing waveform for the solenoids. The control program will need to calculate incremental steps and send these steps to the power supply control card. The waveform that would need to be calculated is of the form:

$$I(t) = I_0 \exp\left(-\frac{t}{T_s}\right) \cdot \sin\left(2\pi \cdot \frac{t}{T_p}\right)$$

where I_0 is the operational current, T_s is the damping time and T_p is the current oscillation period.

8.0 Coupler Port (CP) & RF Connections

The SSR1 cryomodule has eight Coupler ports located along the length of the Cryomodule. The coupler ports include the RF connection and associated instrumentation. Figure 8.1 shows the locations of the coupler ports.

The SSR1 provides an RF input connection: 3 1/8" EIA standard 50 Ohm Coax.

AD/RF team provides RF distribution to this point, including any directional couplers, local circulators, and circulator loads.

Each port accommodates multiple connections in addition to the RF input. A list of the connectors, sensor type and other information of the coupler ports instrumentation can be seen in table 8.3 below.

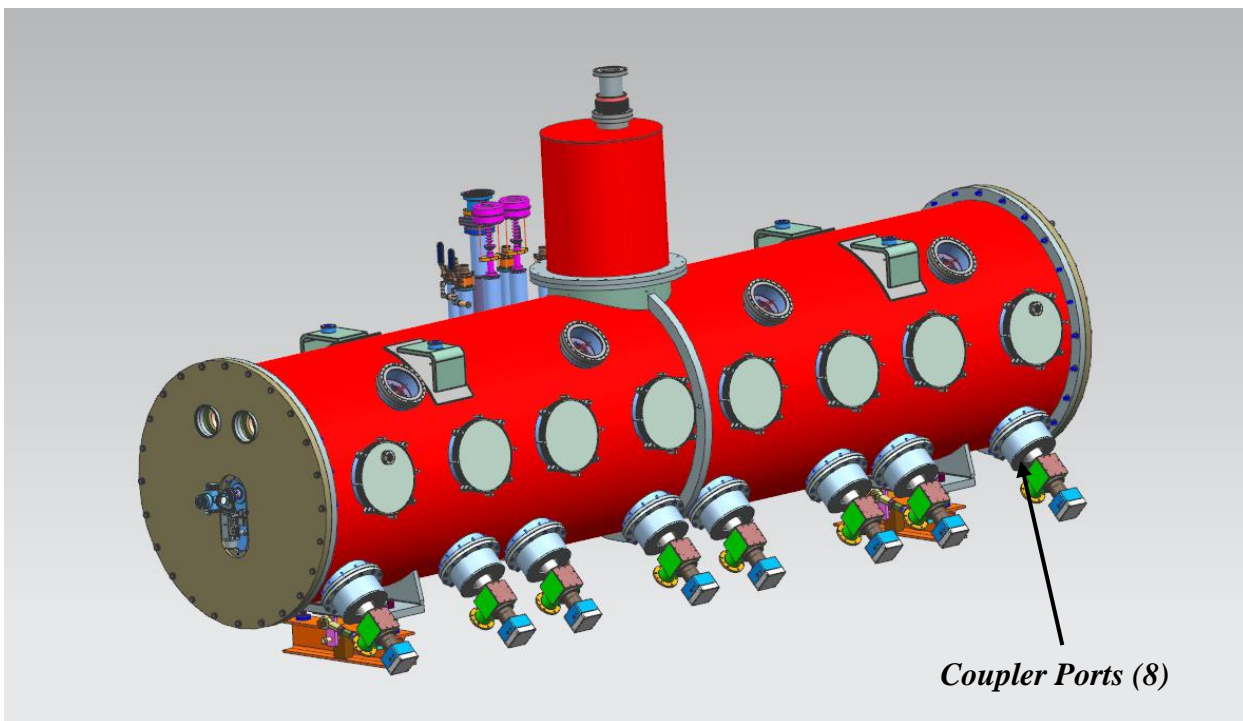

Figure 8.1: Locations of Coupler Ports

A prototype of the coupler is shown under test in figure 8.2. The operating voltage is between 4 and 8 kV. Couplers for SSR1 at PIP-II Injector Test will be rated and tested to 20kW [4].

In addition to the RF input, each coupler port accommodates other instrumentation and interface points:

- One RF field probe (i.e. the E-pickup)
- Thermometry for various points in the coupler
- Connections for field emission probe, which looks for emitting electrons
- Two air inlets (see section 5)
 - 1 air inlet (A) uses dry room temperature air to keep the ceramic window warm
 - 1 air inlet (B) to keep the inlet RF power chamber cool
- A connection for high voltage bias
- A power supply connection for the Photo multiplier tube (PMT) which is looks at the ceramic window.
- A connection for the PMT signal

The connections and pinouts of these interfaces are tabulated in Table 8.3

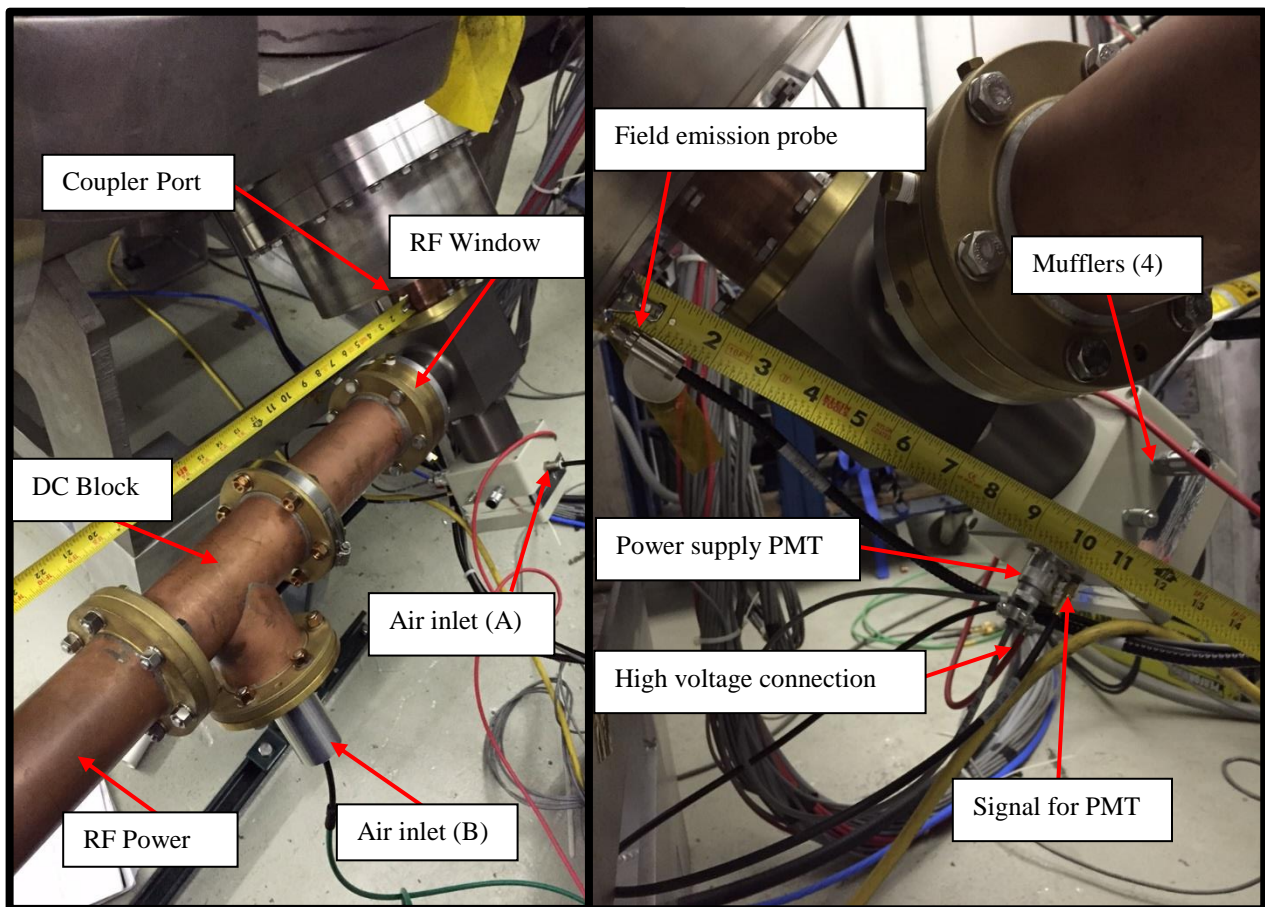

Figure 8.2: First is the front view of coupler port in testing. Second is side view to show connection on back side.

Table 8.3: RF coupler connections. Typical at each coupler port

Function	Type	Sensor Make / Model	Pinout at Interface Connector			
			Interface Connector Make / Model	Signal	Connector ID	Pin
Cavity Field Probe	E-pickup		N-type	signal	1	inner conductor
				ground		outer conductor
Temp Sensor 1 - low temp	2-wire RTD	LakeShore / CX-1030-SD-HT	Detoronics / DT02H-14-19PN	V+	2	TBD
Temp Sensor 2 - low temp	2-wire RTD	LakeShore / CX-1030-SD-HT		V-		TBD
Temp Sensor 3 - high temp	4-wire RTD	LakeShore / PT-102	Detoronics / DT02H-14-19PN	V+	3	TBD
				V-		TBD
				I+		TBD
				I-		TBD
Temp Sensor 4 - high temp	4-wire RTD	LakeShore / PT-102	Detoronics / DT02H-14-19PN	V+		TBD
				V-		TBD
				I+		TBD
				I-		TBD
Temp Sensor 5 - high temp	4-wire RTD	LakeShore / PT-102	Detoronics / DT02H-14-19PN	V+	TBD	
				V-	TBD	
				I+	TBD	
				I-	TBD	
Temp Sensor 6 - high temp	4-wire RTD	LakeShore / PT-102	Detoronics / DT02H-14-19PN	V+	TBD	
				V-	TBD	
				I+	TBD	
				I-	TBD	
Heater 1	resistance heater, 15W, TBD V		Sealtron / 8673-14B-4PN-SP-M121	V+	4	TBD
				ground		TBD
Heater 2	resistance heater, 15W, TBD V			V+		TBD
				ground		TBD
Field emission probe					5	
Photomultiplier Tube Power					6	
Photomultiplier Tube Signal					7	
HV Bias			SHV	HV	8	inner conductor
				ground		outer conductor

9.0 Tuners and Tuner Access Ports (TAP)

The SSR1 Cryomodule will have a tuner on each cavity. The tuners attach to each cavity shown in figure 9.1.

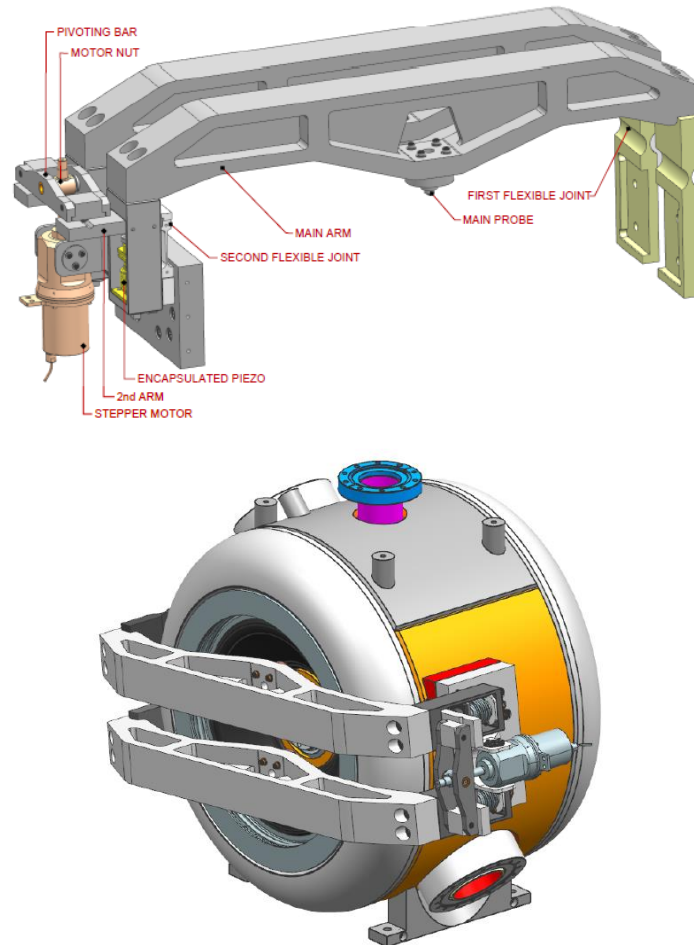

Figure 9.1: SSR1 tuner configuration

These tuners consist of a stepper motor, piezos, 2 limit switches and a temperature probe. The tuners are accessed via the tuner access ports (TAPS) which are located on the side of the cryomodule shown in figure 9.2. The entire actuation group is assembled on a removable cartridge in order to increase its reliability allowing the removal from the cryomodule via the tuner access port in the case of failure of one of the components. Please see ED0000165 [5] for more detailed information on the cavity tuner.

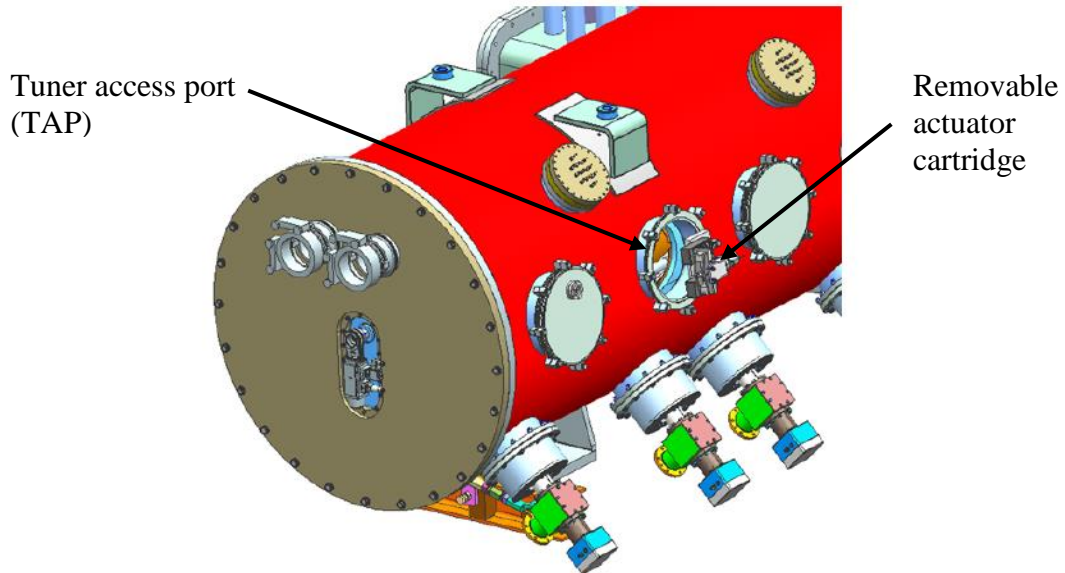

Figure 9.2: Access ports to the removable cartridge

Nomenclature and numbering

The eight Tuner Access Ports are identified by their associated cavity (e.g. TAP1 through TAP8, TAP1 services cavity 1). Each TAP accommodates several multi-pin electrical connectors. Each connector is assigned an identifying number. So for example TAP1-3 refers to connector #3 on Cavity 1's Tuner Access Port.

The connections hosted on the TAPs cover not only tuner-associated hardware, but also miscellaneous instrumentation (BPMs, liquid level, etc.).

Connections present on every TAP (e.g. motion control for the tuner) are shown in Table 9.3

Connections present only on some TAPs (e.g. helium level probe interfaces are all on TAP1) are shown in Table 9.4

Table 9.3: Connections common to ALL Tuner Access Ports (i.e. 8 places total)

Function	Type	Device Make / Model	Pinout at Interface Connector				
			Interface Connector Make / Model	Signal	Connector ID	Pin	
Tuner - Piezo #1			Detoronics / DT02H-16-8PN		TAP_-1		
Piezo#1-1(+)				V+		TBD	
Piezo#1-1(-)				V-		TBD	
Piezo#1-2(+)				V+		TBD	
Piezo#1-2(-)				V-		TBD	
Tuner - Piezo #2							
Piezo#2-1(+)				V+		TBD	
Piezo#2-1(-)				V-		TBD	
Piezo#2-2(+)			V+	TBD			
Piezo#2-2(-)			V-	TBD			
Drive - stepper motor	Bipolar / full step operation / 2.5A current limit	Phytron actuator for cryogenic vacuum (LVA 53-LCLSII-UHVC-X1)	Detoronics / DT02H-16-8PN	Phase A	TAP_-2	TBD	
				Phase A'		TBD	
				Phase B		TBD	
				Phase B'		TBD	
Limit switch - stepper motor inboard	Normally closed, open at limit	Jaidinger/S15-276		V+		TBD	
				V-		TBD	
Limit switch - stepper motor outboard	Normally closed, open at limit	Jaidinger/S15-276		V+		TBD	
				V-		TBD	

Table 9.3 (continued): Connections common to ALL Tuner Access Ports (i.e. 8 places total)

Function	Type	Device Make / Model	Pinout at Interface Connector			
			Interface Connector Make / Model	Signal	Connector ID	Pin
Temperature - stepper motor	4-wire RTD	LakeShore / PT-102	Detoronics / DT02H-14-19PN	V+	TAP_-3	TBD
				V-		TBD
				I+		TBD
				I-		TBD
Cavity field probe			Hutton / H+S 34-N-50-0-3/133NE	signal	TAP_-6	inner conductor
			ground	outer conductor		
Temperature - cavity vessel	Cernox RTD	LakeShore/ CX-1030-SD-HT	Detoronics / DT02H-14-19PN	V+	TAP_-7	TBD
				V-		TBD
				I+		TBD
				I-		TBD
Temperature - cavity vessel	Cernox RTD	LakeShore/ CX-1030-SD-HT	Detoronics / DT02H-14-19PN	V+	TAP_-7	TBD
				V-		TBD
				I+		TBD
				I-		TBD

Table 9.4: Connections present on only some Tuner Access Ports

Function	Type	Device Make / Model	Pinout at Interface Connector				
			Interface Connector Make / Model	Signal	Connector IDs	Pin	
2K phase separator - level	Helium level probe		Detoronics / DT02H-14-19PN	TBD	TAP1-4	TBD	
				TBD		TBD	
				TBD		TBD	
				TBD		TBD	
2K phase separator - level	Helium level probe			TBD		TAP1-4	TBD
				TBD			TBD
				TBD			TBD
				TBD			TBD
2K phase separator - temp	Cernox RTD	Lakeshore/CX-1030-SD-HT		V+	TAP1-4		TBD
				V-			TBD
				I+			TBD
				I-			TBD
2K phase separator - temp	Cernox RTD	Lakeshore/CX-1030-SD-HT	V+	TAP1-4		TBD	
			V-			TBD	
			I+			TBD	
			I-			TBD	
Current lead temp	Cernox RTD	Lakeshore/CX-1030-SD-HT	Detoronics / DT02H-14-19PN		V+	TAP5-4	TBD
					V-		TBD
					I+		TBD
					I-		TBD
Current lead temp	Cernox RTD	Lakeshore/CX-1030-SD-HT		V+	TAP5-4		TBD
				V-			TBD
				I+			TBD
				I-			TBD
Current lead temp	Cernox RTD	Lakeshore/CX-1030-SD-HT		V+		TAP5-4	TBD
				V-			TBD
				I+			TBD
				I-			TBD
Current lead temp	Cernox RTD	Lakeshore/CX-1030-SD-HT	V+	TAP5-4	TBD		
			V-		TBD		
			I+		TBD		
			I-		TBD		

Table 9.4 (continued): Connections present on only some Tuner Access Ports

Function	Type	Device Make / Model	Pinout at Interface Connector			
			Interface Connector Make / Model	Signal	Connector IDs	Pin
BPMs					TAP2-_ TAP4-_ TAP6-_ TAP8-_ 	see BPM section for details
Thermal shield temps	4-wire RTD	Lakeshore/PT-102	Detoronics / DT02H-14-19PN	V+	TAP3-4 and TAP7-4	TBD
				V-		TBD
				I+		TBD
				I-		TBD
Thermal shield temps	4-wire RTD	Lakeshore/PT-102		V+		TBD
				V-		TBD
				I+		TBD
				I-		TBD
Thermal shield temps	4-wire RTD	Lakeshore/PT-102		V+	TBD	
				V-	TBD	
				I+	TBD	
				I-	TBD	
Thermal shield temps	4-wire RTD	Lakeshore/PT-102		V+	TBD	
				V-	TBD	
				I+	TBD	
				I-	TBD	

Note: where multiple connector IDs are listed, this configuration applies to each listed TAP. E.g, on both TAP3 and TAP7, connector #4 hosts qty. 4 RTDs.

Table 9.4 (continued): Connections present on only some Tuner Access Ports

Function	Type	Device Make / Model	Pinout at Interface Connector			
			Interface Connector Make / Model	Signal	Connector IDs	Pin
Strongback temps	4-wire RTD	Lakeshore/PT-102	Detoronics / DT02H-14-19PN	V+	TAP3-5 and TAP7-5	TBD
				V-		TBD
				I+		TBD
				I-		TBD
V+	TBD					
V-	TBD					
I+	TBD					
I-	TBD					
Strongback temps	4-wire RTD	Lakeshore/PT-102		V+	TAP3-5 and TAP7-5	TBD
				V-		TBD
				I+		TBD
				I-		TBD
V+	TBD					
V-	TBD					
I+	TBD					
I-	TBD					
Strongback temps	4-wire RTD	Lakeshore/PT-102	V+	TAP3-5 and TAP7-5	TBD	
			V-		TBD	
			I+		TBD	
			I-		TBD	
V+	TBD					
V-	TBD					
I+	TBD					
I-	TBD					
Strongback temps	4-wire RTD	Lakeshore/PT-102	V+	TAP3-5 and TAP7-5	TBD	
			V-		TBD	
			I+		TBD	
			I-		TBD	
V+	TBD					
V-	TBD					
I+	TBD					
I-	TBD					
Heaters - He Vessel	resistance heater	Omega / KHLV-105/5	Sealtron / 8673-14B-4PN-SP-M121	V+	TAP2-5 TAP4-5	TBD
	V-	TBD				
Heaters - He Vessel	resistance heater	Omega / KHLV-105/5		V+	TAP5-5 TAP6-5	TBD
	V-	TBD				
Beam tube temp	Cernox RTD	Lakeshore/CX-1030-SD-HT	Detoronics / DT02H-14-19PN	V+	TAP1-5 TAP8-5	TBD
				V-		TBD
				I+		TBD
				I-		TBD

Note: where multiple connector IDs are listed, this configuration applies to each listed TAP. e.g, on both TAP3 and TAP7, connector #5 hosts qty. 4 RTDs.

Table 9.4 (continued): Connections present on only some Tuner Access Ports

Function	Type	Device Make / Model	Pinout at Interface Connector			
			Interface Connector Make / Model	Signal	Connector IDs	Pin
Temp: 2K-4K heat exchanger	4-wire RTD	TBD	TBD SSR1 team needs to include in design	V+	TBD	TBD
				V-		TBD
				I+		TBD
TX 730-H				I-		TBD
Temp: 2K-4K heat exchanger	4-wire RTD	TBD		V+		TBD
				V-		TBD
				I+		TBD
TX 731-H				I-		TBD
Temp: 2K-4K heat exchanger	4-wire RTD	TBD		V+		TBD
				V-		TBD
				I+		TBD
TX 732-H				I-		TBD
Temp: 2K-4K heat exchanger	4-wire RTD	TBD	V+	TBD		
			V-	TBD		
			I+	TBD		
TX 733-H			I-	TBD		

10.0 Beam Position Monitors

The SSR1 includes four cold BPMs. Connections for the BPMs are accommodated on the Tuner Access Ports with significant space allowed for ease of installation. The pinout for each BPM is shown in Table 10.1 below. The orientation of buttons shall be defined w.r.t. the PIP-II Injector Test beamline coordinate system as shown in Figure 10.2.

Table 10.1: BPM connection pinouts

Function	Device Make / Model	Pinout at Interface Connector			
		Interface Connector Make / Model	Signal	Connector ID	Pin
BPM	ANL	Hutton / H+S 34-N-50-0-3/133NE	+X Button	TAP2-TBD TAP4-TBD TAP6-TBD TAP8-TBD	inner conductor
		Hutton / H+S 34-N-50-0-3/133NE	-X Button	TAP2-TBD TAP4-TBD TAP6-TBD TAP8-TBD	inner conductor
		Hutton / H+S 34-N-50-0-3/133NE	+Y Button	TAP2-TBD TAP4-TBD TAP6-TBD TAP8-TBD	inner conductor
		Hutton / H+S 34-N-50-0-3/133NE	-Y Button	TAP2-TBD TAP4-TBD TAP6-TBD TAP8-TBD	inner conductor

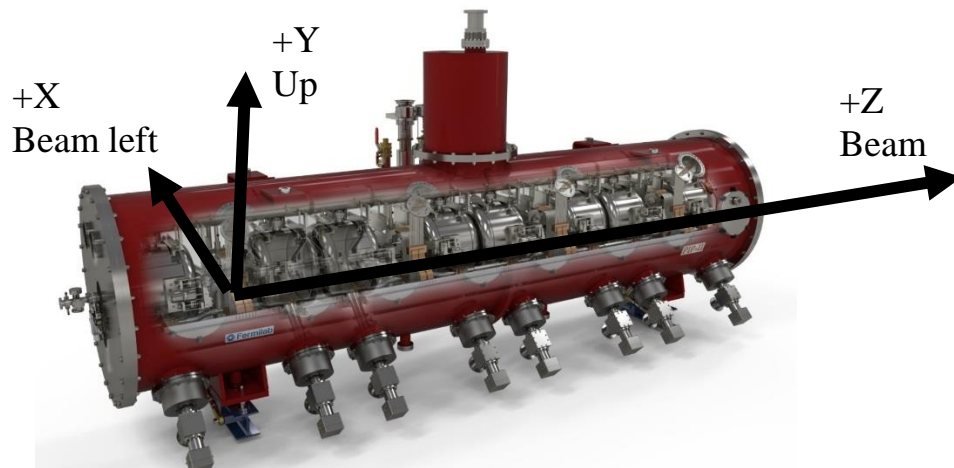

Figure 10.2: PIP-II Injector Test beamline coordinate system, BPM button nomenclature convention

11.0 Cryogenic Connections

Cryogenic Circuits

The schematic of the cryomodule cryogenic piping is shown in Figure 11.1 and 11.2

The SSR1 Cryomodule will have three sections held at different temperatures:

- The outer shield is held at 45-80K with gaseous Helium
- The inner shield is held at 5K with liquid helium
- The cavities and solenoids are held at 2K with superfluid liquid helium

Interfaces of each circuits are as follows:

- The 45-80 K and 5 K helium connections are through Fermilab Bayonets (F10006005)
- The sub atmospheric pumping line holding the 2K circuit at low pressure is the large bayonet of JLAB design (need drawing).

Location of the interface points is shown in figures 11.3 and 11.4. Dimensional information is captured in [2].

The SSR1 includes two WEKA DN15 cryo valves, serving as a JT valve and a cooldown control valve. The data sheet for the cryo valves can be viewed in the appendix.

Cryogenic controls

The SSR1 itself does not include any controls, only the instrumentation and pneumatic valves as described herein. The AD/Cryo team is responsible for implementing controls to achieve and maintain the requisite operation parameters of the SSR1.

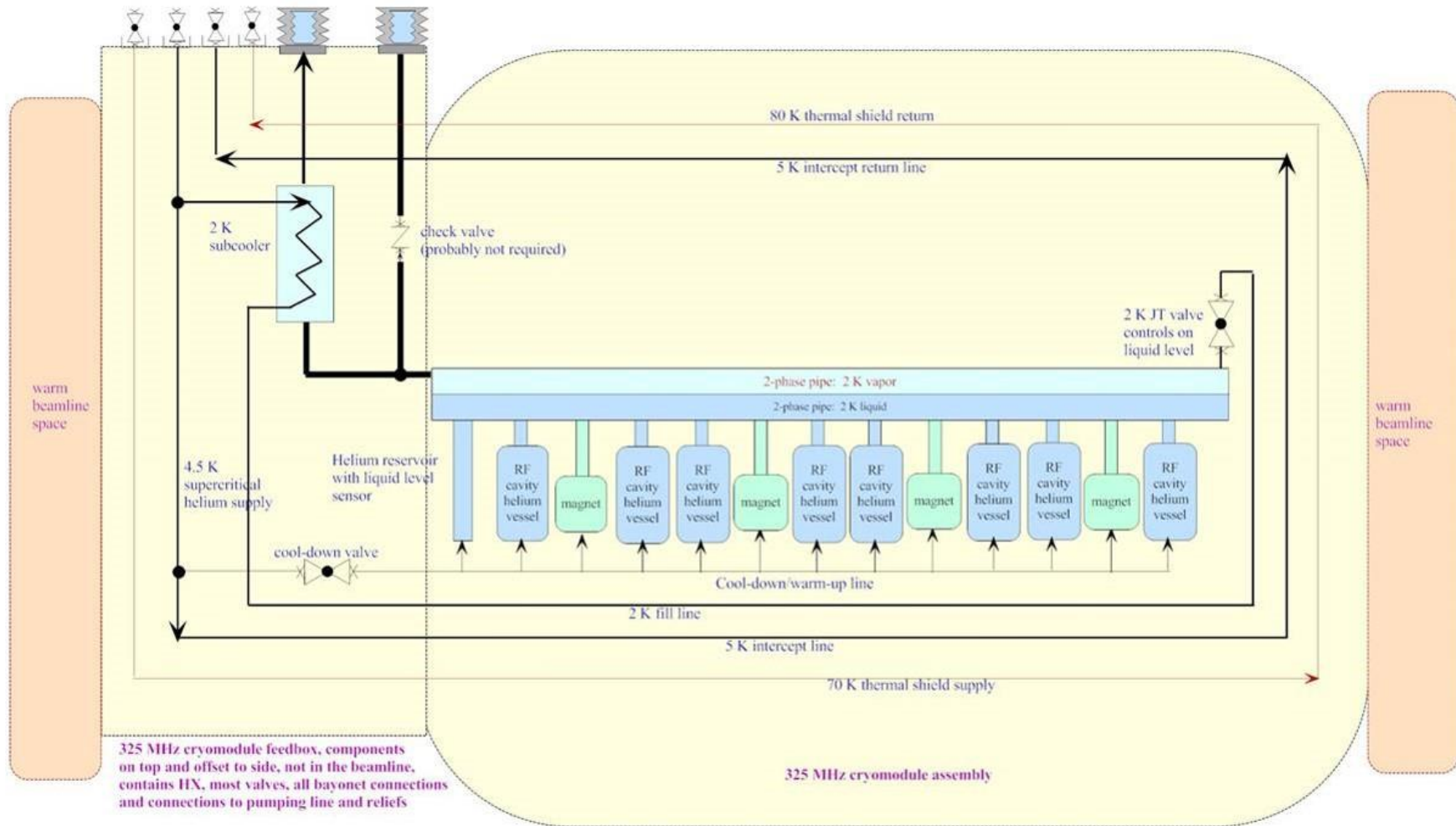

Figure 11.1: SSR1 Cryo Piping Block Diagram

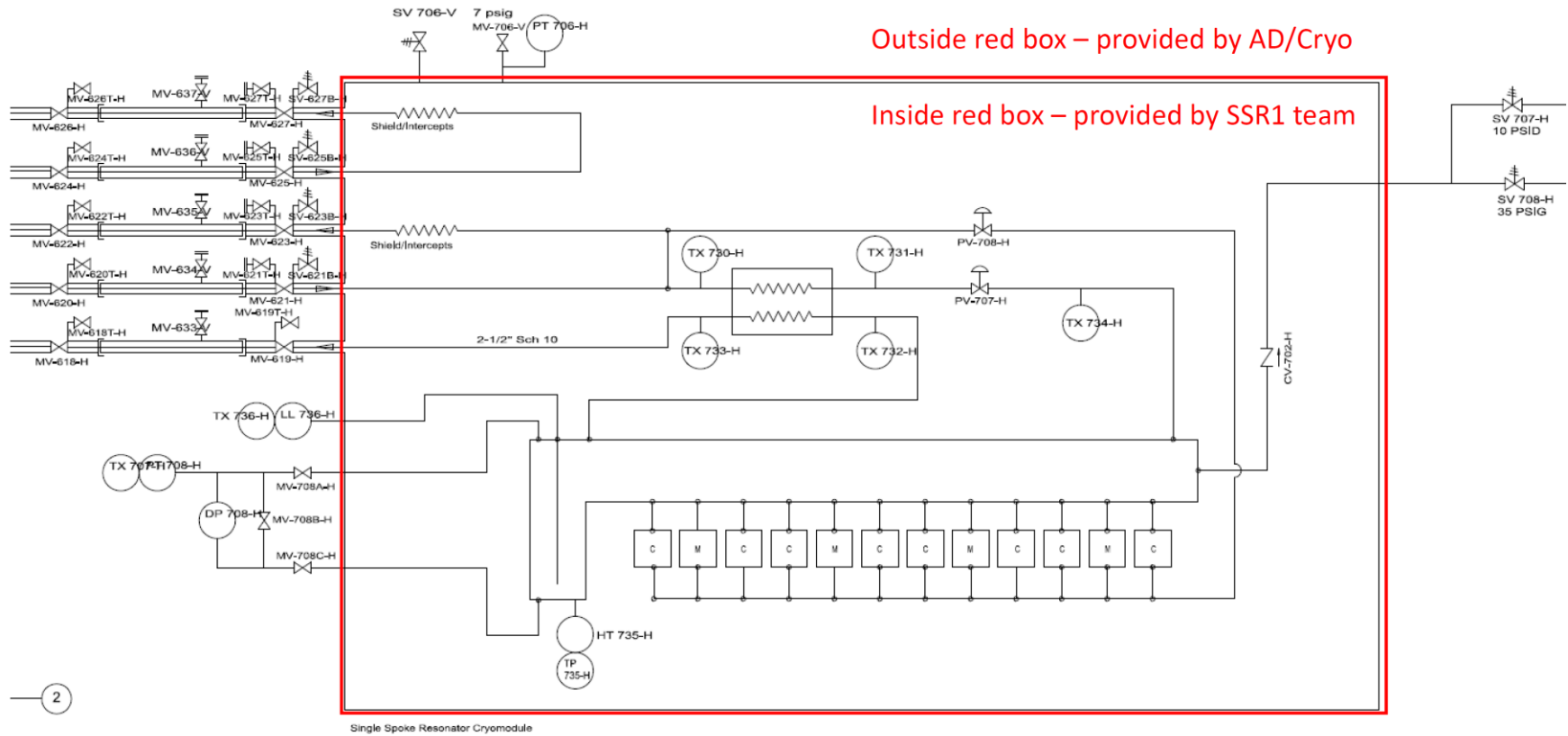

Figure 11.2: SSR1 Cryo Interface P&ID [6]

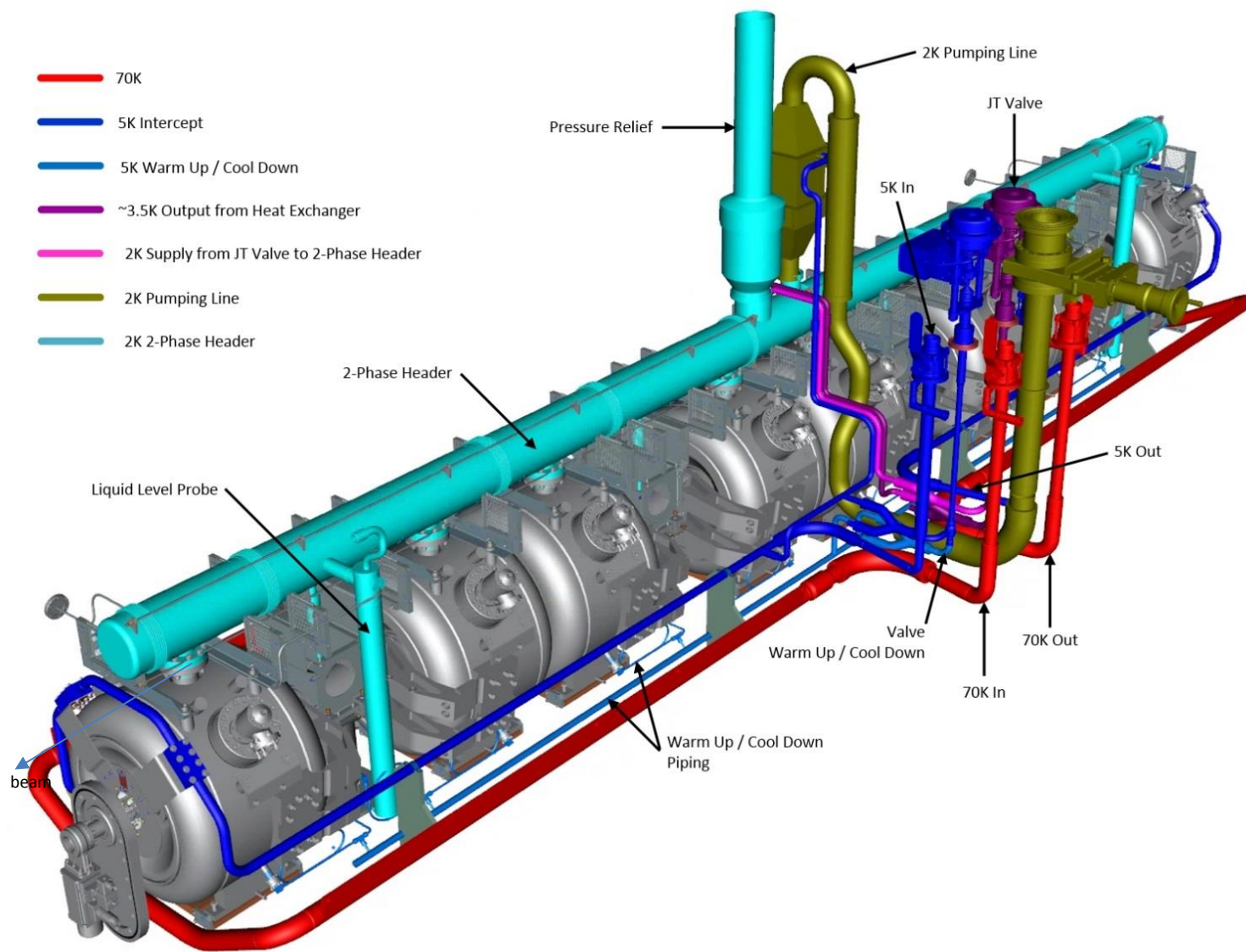

Figure 11.3: SSR1 Cryogenic circuits

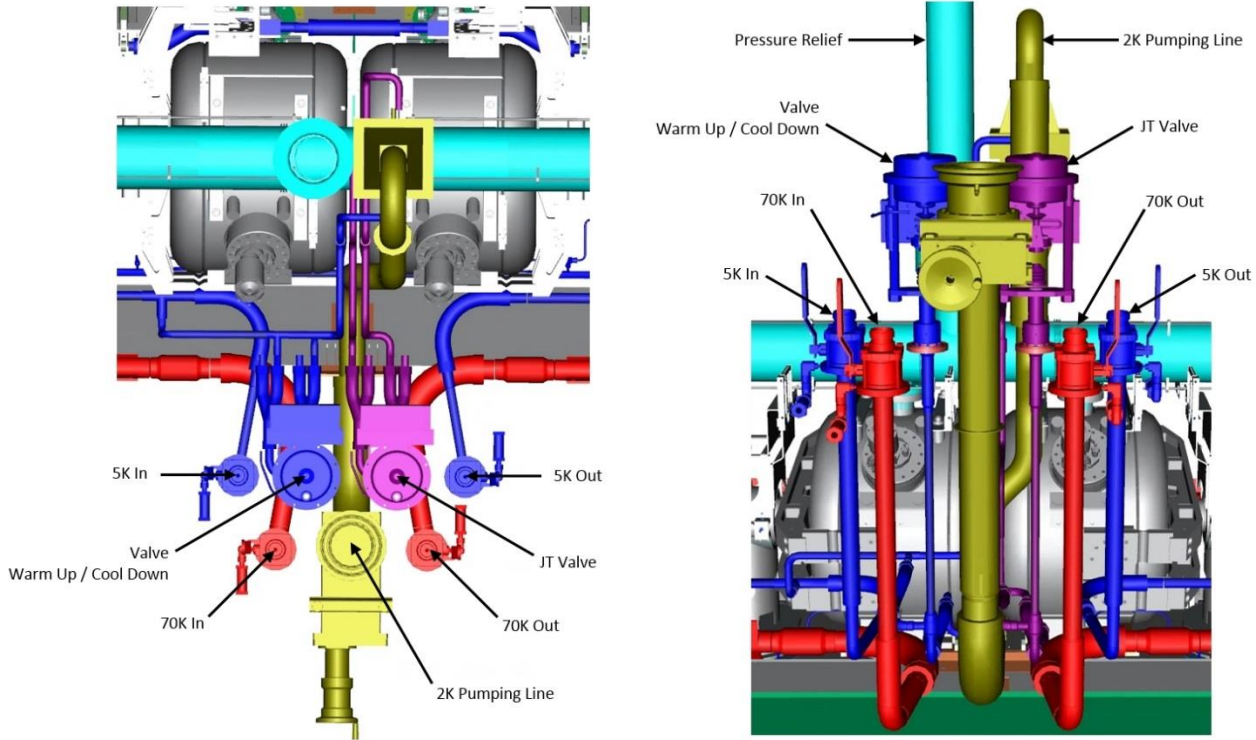

Figure 11.4: SSR1 Cryogenic connections

Coldmass Mass

In order to design the PIP-II Injector Test Cryo Distribution System (CDS), it is necessary to define the thermal cold mass in each temperature regime. The SSR1 shall have cold masses as specified in the table below:

Temperature	Mass	Comments
Mass at ~70K	3.0E2 kg +/- 5%	No mass for bayonets and JT with connecting lines, no mass for thermal straps
Mass at 5K	4.5E1 kg +/- 10%	No mass for bayonets and JT with connecting lines, no mass for thermal straps
Mass at 2K	1.9E3 kg +/- 5%	No mass for bayonets and JT with connecting lines, no Power couplers and thermal straps

Pressure Relief

The SSR1 includes a port for pressure relief of the 2K circuit, as shown in Figure 11.5. The port is a 6.75" Conflat flange (6" Conflat requested by AD, this is to be investigated in design). The SSR1 does not include a relief valve on this line.

The SSR1 does not provide pressure relief of the 45-80K or 5K circuits. Pressure relief shall be provided as part of the AD/Cryo Cryogenic Distribution System

The SSR1 does provide an integral parallel-plate pressure relief for the cryostat.

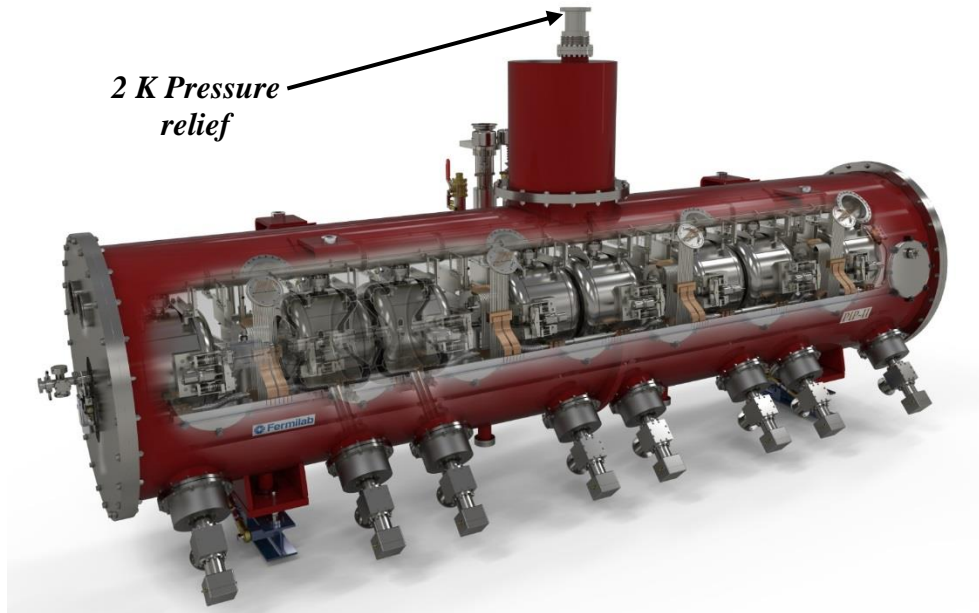

Figure 11.5: 2K Pressure Relief Port

Note that the SSR1 will be sensitive to vibration induced by this system. Please see microphonics requirements in section 14.

12.0 Cryomodule Vacuum Systems

Beamline Vacuum

The connection to beamline vacuum is via the gate valves detailed in Section 2.

The SSR1 itself does not provide any pumping of beamline vacuum (except for natural cryo pumping). The AD/Vacuum team shall provide pumping at each end of the SSR1 to achieve requisite vacuum levels before and after cooldown, as shown in Table 12.2.

All vacuum work on the SSR1 beamline vacuum and adjacent vacuum systems shall follow low-particulate UHV vacuum practices as defined in the PIP-II Injector Test Vacuum FRS [7].

The CMTF/Facilities team shall provide a cleanroom and mass-flow-control pumping station for use with the SSR1.

Insulating Vacuum

The SSR1 deliverable does not include any pumping of insulating vacuum (except for natural cryo pumping).

The SSR1 does provide a 6" Conflat port for insulating vacuum pumping hardware, the location is shown in Figure 12.1

The AD/Vacuum team shall provide insulating vacuum hardware to achieve requisite vacuum levels before and after cooldown, as shown in Table 12.2

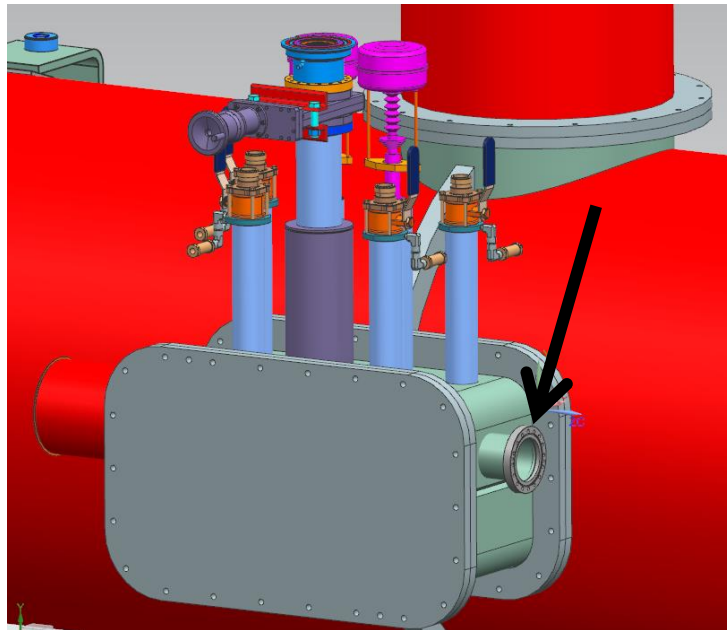

Figure 12. 1: Insulating Vacuum Pumping Port

Coupler Vacuum – none

There is no separate coupler vacuum on SSR1

Target Vacuum Levels

Maximum H₂ flux from the HEBT to the SSR1 shall be **INSERT**. AD/Vacuum is responsible for oversight of HEBT/Dump design to ensure this requirement is met.

Note – HWR cryopumping is assumed to effectively isolate SSR1 from MEHT-generated H₂. As such, no SSR1-based requirement is levied on the MEHT.

The PIP-II Injector Test vacuum system shall be designed to achieve vacuum levels in the SSR1 as specified in Table 12.2. The AD/Vacuum team is responsible for design and oversight to ensure these requirements are met:

Table 12.2 – Vacuum requirements

Requirements and devices of the cryomodule vacuum subsystems

		Beamline vacuum	Insulating vacuum
Description		In contrast to storage ring type light sources, here the beam particles pass the straight linac only once. Therefore the beamline vacuum pressure requirement with respect to losses due to scattering on the residual gas are relaxed. Effects like emittance growth, fast ion instabilities or dynamic pressure increase due to synchrotron radiation are negligible. However, particles can act as field emitters and thus limit the performance of the cavities.	The insulating vacuum serves to minimize convective heat transfer to the cavity helium vessel and heat conduction through residual gas the MLIs. For this purpose, a pressure of less than 1.0×10^{-4} Torr is required for the insulating vacuum space.
Pressure(Torr)	At cold	$\leq 1 \times 10^{-10}$	$\leq 1 \times 10^{-6}$
	prior to cool-down	$\leq 1 \times 10^{-8}$	$\leq 1 \times 10^{-4}$
Characteristics		Particle free pump-down/venting	Pressure dominated by water in MLI, permeation through many O-rings
Pumps	Roughing	Turbo, w/ particle free setup	Roots Blower, then Turbo
	In operation	Ion pump from ends of cryomodule	Turbo
Gauges	Cold cathode gauge	Inverted magnetron, BNC/SHV connectors, 2.75" CFF, MKS #104220008	
	Convection gauge	2.75" CFF, MKS #103170024SH	
All-metal right angle valve		DN-40 CF-R, manual actuator, hexagon head, VAT #54132-GE02	

13.0 Interlocks

RF Interlocks

The AD/RF and AD/interlocks team shall implement RF interlocks. RF interlocks shall be in place during conditioning and operation of the SSR1 cavities.

The RF interlock system monitors signals from the following sources in the SSR1:

1. Monitor the multipacting arc activity in the Coupler using a PMT at the warm region.
2. Three field emission probes located at the warm region of the coupler, the 80 Kelvin region of the coupler, and the cold cavity side of the coupler (5 Kelvin region). These probes monitor the coupler and cavity for plasma inception.
3. The coupler ceramic window temperature on the warm region is monitored using an IR sensor head and a separate PT1000 platinum RTD.
4. Air flow through RF couplers
5. Cavity vacuum soft and hard limits from the cold cathode gauges and the vacuum pumps. The hard limits are programmed into the CC gauge and the vacuum pump. The soft trip limits are programmed into the PLC which digitizes the analog signals from each of these devices. A TTL bit is used to interface these devices to the interlock system when the vacuum level transitions beyond the trip limit.

The main task of the interlock system is to control the fast GaAs switch which enables low level RF (325 MHz signal) to the amplifier. This switch is enabled when all RF interlocks are made up and controlled by a TTL high sourced at the System Control board in the interlock system. In the event of any trip detected, the RF switch is opened in approximately 120 nanoseconds for all type of trips except the Field emission probes where the switch opening is delayed based on the amount of energy deposition required to condition the source away < 1.0 Joule (RF energy times TF pulse duration).

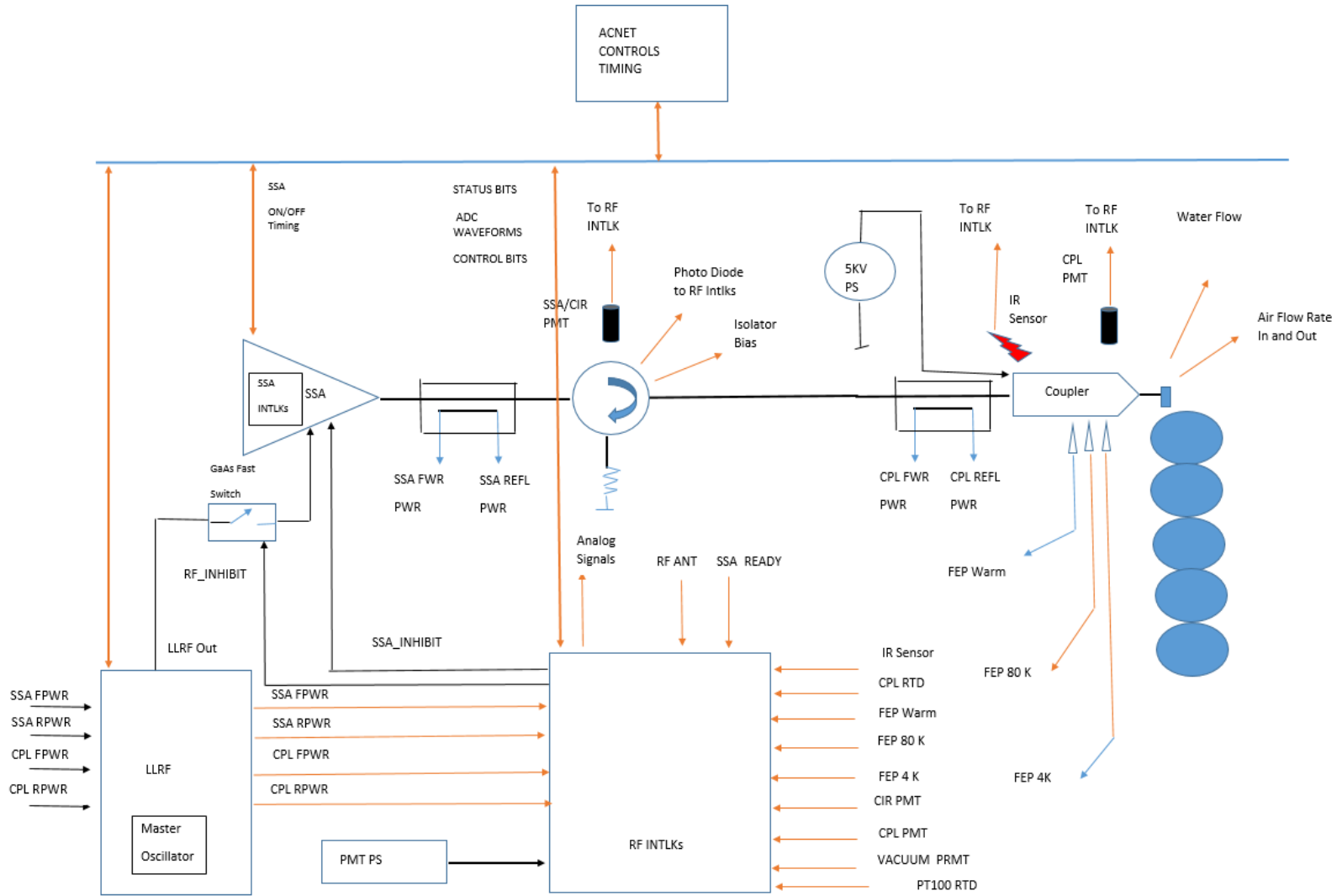

Figure 13. 1: Overview Schematic of the SSR1 interlocks

14.0 Microphonics

Isolation and damping of external sources of vibration from the SSR1 cryomodule is critical to achieve the tight resonance control specifications for PIP-II.

In PIP-II Injector Test, no active vibration control is planned. As such, passive measures are needed to ensure that the vibration environment is workable.

All hardware connecting to SSR1, and all hardware within 3m of the cryomodule shall conform to the vibration control best-practices documented in [8]. This specifies minimum qualitative requirements for system design. Further design and analysis may reveal that more stringent and quantitative requirements are needed for some systems. Specific considerations for some critical interfacing systems are listed below.

Cryogenics

Cryogenic lines should all include bellows/vibration breaks close to the cryomodule, with no hard mountings in between. This should isolate external mechanical vibrations from transmission into the module. Additionally, sharp transitions/restriction of helium flow should be avoided, reducing flow noise. These cryo lines should also be properly constrained and have their movement damped.

Fluids

RF drive lines will have water cooling, and similar best practices can be applied here as to cryo lines: no hard mountings connected to the cryomodule, avoid flow restrictions/transitions/throttling to reduce flow noise. These are less complicated because soft lines can be used, not in a vacuum jacket. These lines should also be properly constrained and have their movement damped.

Gas lines will be used to cool the cavity couplers. Given their proximity to the cavity, it will be important to avoid any flow noise in these lines. Experience with the RFQ air lines indicates that noise should not be an issue as the lines are sized. Additionally, they should be vented far from the cryomodule. Use of soft lines for supply and exhaust reduces danger of vibration transmission.

Cryomodule Footing

The cryomodule will be hard mounted to a girder. That is, it will essentially be rigid to the facility floor. As such, it is important to minimize vibration sources in nearby equipment that can couple into floor.

Beamline Connections

Bellows should be incorporated along the beamline to minimize vibration transmissions. These bellows should be in a free state during operations.

RF Connections

The coax line to the cavities (provided by AD-RF) should incorporate flexibility at the interface to the coupler. This should be implemented with a flexible section of coax near the cryomodule. Damping

should be incorporated to further minimize transmission of vibration. Air flow in the RF couplers should not excite microphonics at dangerous level. .

Signal Connections

Mostly signal wires and small RF cables, these should be all either soft or flexible lines. Some strain relief will likely be built into these wires, and they are not considered a dangerous source of vibration.

External sources and measurement devices

The PIP-II Injector Test/CMTF facility was designed with consideration for vibration isolation. For example, the cryoplant is built on a separate foundation. Hardware near the cryomodule should be designed and installed per the best practices document [8]. However, given that PIP-II Injector Test is a shared facility and a test facility, there is currently no intention to impose broad vibration-control requirements or operations constraints within the facility. Experience with PIP-II Injector Test will guide further thinking in this matter.

The PIP-II Injector Test/Facilities team shall provide environment monitoring devices close to SSR1 so that environmental vibrations can be monitored. In the case of unacceptable microphonics, this system may be used to identify and mitigate driving sources.

Internal Monitoring Devices

There are no requirements or plans to incorporate vibrating measuring devices in the cryomodule.

References

- [1] Drawing F10002433: Assembly, Cryomodule 325MHz.
- [2] Drawing F10049253: Installation, SSR1 Cryomodule.
- [3] Drawing F10051422: ENVELOPE, TRANSVERSE, PIP-II CRYOMODULES.
- [4] ED0001777: FRS, 325 MHz Coupler.
- [5] ED0000165: Specification for the SSR1 tuner.
- [6] Drawing F10042546: P&ID, PIP2IT Cryogenic Distribution System.
- [7] ED0004444: FRS, PXIE Vacuum Systems.
- [8] ED0002931: Vibration control best-practices for PXIE.

Appendix

VAT

 VAT Vakuumventile AG CH-9469 Haag, Schweiz	Product data sheet Mini UHV gate valve, Series 010, DN 40 (ID 1½") Ordering No. 01032-UE41
--	---

Description

Flange	CF-F 40 UNF
Actuator	pneumatic, single acting with closing spring – with solenoid valve – with position indicator
Feedthrough	Bellows

Technical data

Leak rate	– Valve body – Valve seat	$< 5 \cdot 10^{-10}$ mbar ls ⁻¹ $< 1 \cdot 10^{-9}$ mbar ls ⁻¹
Pressure range		$1 \cdot 10^{-10}$ mbar to 2 bar (abs)
Differential pressure on the gate		≤ 2 bar
Differential pressure at opening		≤ 30 mbar
Conductance (molecular flow)		220 ls ⁻¹
Cycles until first service		50 000
Temperature (Maximum values: depending on operating conditions and sealing materials)	– Valve Body – Actuator – Solenoid valve – Position indicator	≤ 250 °C open / ≤ 200 °C closed (bake-out max. 24h) ≤ 200 °C ≤ 50 °C ≤ 80 °C
Heating and cooling rate		≤ 50 °C h ⁻¹
Material	– Valve Body – Gate – Bellows	AISI 304 (1.4301), AISI 316L (1.4435) AISI 304 (1.4301) AISI 316L (1.4404, 1.4435)
Seal	– Bonnet – Gate – Actuator	metal FKM (Viton®), vulcanized FKM (Viton®)
Mounting position		any
Volume of pneumatic actuator		0.12 l / 0.004 ft ³
Compressed air min. – max. overpressure		5 – 7 bar / 73 – 102 psi
Compressed air connection		G ½" (½" NPT for USA)
Actuation time	– closing – opening	0.7 s 0.7 s
Weight		4.2 kg / 9.26 lbs

WEKA CRYO VALVE

WEKA AG, CH4344 Birmenswil & CH-2000 La Chaux-de-Fonds, Switzerland
 Phone +41 69 892 6400, Fax +41 69 800 4200, info@weka.ch, CH-BAW Birmenswil
 Phone +41 20 285 97 00, Fax +41 20 285 94 22, info@weka.ch, CH-2000 La Chaux-de-Fonds
 info@weka.ch - www.weka.ch

Rev. June 2010 - F160 / Page 3 of 11

Dimensions for Standard Cryogenic Valve PN25, Bellows Sealed, with Pneumatic Actuator, Type PIP-TEV DN...PNL

- Base assumption for design pressure & temperature for valve only body, spindles with bellows etc.: 25 barg @ 20°C - PN25.
- For bigger DN sizes, lower PN pressure i.e. PN10, PN16 or PN20 may be advisable considering heat load! For smaller DN same valve may be used up to PN40 or PN50 respectively.
- PN pressure is also applicable down to -273°C respectively -20°C. For higher temperature act P-T diagram as well as sealing materials!
- Dimensions are indicated for valves with pneumatic diaphragm actuator for shut-off pressure as shown.
- Control valves with digital electro-pneumatic positioner (digital pneumatic with electronic control)

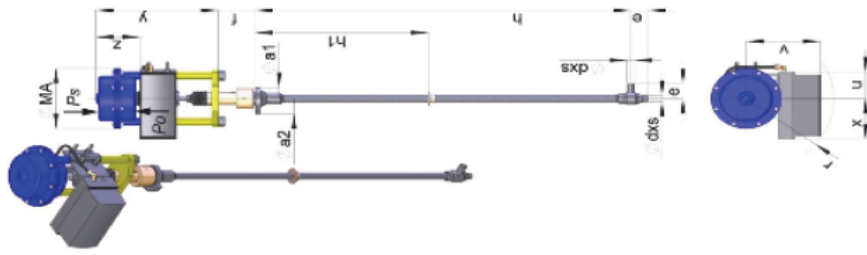

Normal Valve Size DN (= nominal size in inch)	Normal Valve Size DN PN25	Normal Valve Size DN PN15	Normal Valve Size DN PN10
Seat dia. [mm]	38	38	38
Travel [mm]	10	10	10
Rated as Control Valve (Optimal) or Control Valve (Optimal) or Shut-Off Valve (Optimal) or Control Valve (Optimal)	2.80	2.80	2.80
Rated as Digital or Shut-Off Valve (Optimal) or Control Valve (Optimal)	3.25	3.25	3.25
Rated as Digital or Shut-Off Valve (Optimal) or Control Valve (Optimal)	3.00	3.00	3.00
Rated as Digital or Shut-Off Valve (Optimal) or Control Valve (Optimal)	3.49	3.49	3.49
Valve	dia. 60.0	dia. 60.0	dia. 60.0
Vacuum weld in temp. WEKA cat. no. 19910200, 41 [mm]	17.2/1.6	17.2/1.6	17.2/1.6
Vacuum weld in temp. WEKA cat. no. 19910201, 42 [mm]	40	40	40
Ball weld end, dia. 25 [mm]	35	35	35
Chryogen length l_1 , recommended only [mm]	down to 4.2K min. h=800 / h=975, see table up to max. 1000	down to 4.2K min. h=800 / h=975, see table up to max. 1000	down to 4.2K min. h=800 / h=975, see table up to max. 1000
Heat load 300 to 4.2K @ 100K of length in [W]	down to 27K min. h=800	down to 27K min. h=800	down to 27K min. h=800
Heat load 300 to 22K @ 100K of length in [W]	down to 77K min. h=800	down to 77K min. h=800	down to 77K min. h=800
Heat load 300 to 77K @ 100K of length in [W]	h=800 $\leq 0.55W$ / h=975 $\leq 0.55W$ / h=1000 $\leq 0.55W$	h=800 $\leq 0.75W$ / h=975 $\leq 0.50W$ / h=1000 $\leq 0.45W$	h=800 $\leq 0.75W$ / h=975 $\leq 0.50W$ / h=1000 $\leq 0.45W$
Thermal conduct. in [mm]	h=800 $\leq 0.90W$	h=800 $\leq 0.90W$	h=800 $\leq 0.90W$
Pneumatic Diaphragm Actuators	see catalogue no. WEKA_19900435	see catalogue no. WEKA_19900435	see catalogue no. WEKA_19900435
Valve end of pressure bar	$\leq 10\text{bar}$	$\leq 10\text{bar}$	$\leq 10\text{bar}$
Type	MA 10A6	MA 10A6	MA 10A6
dia. MA [mm]	162	162	162
y [mm]	281	281	281
z [mm]	100	100	100
Control pressure max/max. for the actuators bar/g	3.0/0.0	3.0/0.0	3.0/0.0
Max. IN/PI or air supply act/2 and dia. of 27KVI, 0.02bar	0.40	0.40	0.40
Control pressure max/max. for the actuators bar/g	3.0/3.2	3.0/3.2	3.0/3.2
Max. IN/PI or air supply act/2 and dia. of 27KVI, 0.02bar	0.40	0.40	0.40
1-g positions, dimensions L, W, Y and X, assumed for			
AWZ/ANZE/27A/SFAH/T PS2			
SAMSON series 3732			
	h=200 / u=107 / w=172 / h=110	h=200 / u=107 / w=172 / h=110	h=200 / u=107 / w=172 / h=110
	h=180 / u=107 / w=150 / h=57	h=180 / u=107 / w=150 / h=57	h=180 / u=107 / w=150 / h=57

- Abbreviations: P=normally closed actuation / Ph=normally open actuation
- Mounting position: Valves are assumed for mounting in vertical direction, actuator on top, max. 45° from vertical. For higher angles from vertical up to min. 20° from horizontal and with liquid cryogenic service use connection table may recommended, see catalogue no. WEKA_19901008 Connection-table
- Heat load: Cryogenic length h basically possible according order specification, indicated length is recommended as standard for the respective LH2, or LNG service
- To reduce of heat load, cryogenic length "h" could be elongated up to the indicated max. length possible w/o further technical considerations.
- For further reduction of heat load an thermal contact in Cu may be added by Ag-brazing, see catalogue no. WEKA_19900435, ThermalContact
- Sealing to outside: Further reduction of heat load with modified insert as compound design in ss and G10 tube is available on request, see catalogue no. WEKA_20090801_G10Insert
- For valves with body shape in globe pattern, D- or G-design, Y-stamped or shilled inlet/outlet as called Z-pattern see catalogue no. WEKA_19900208_SpindleSealing
- For superfluid HeII in sub-atmosphere pressure He-guard space seal system to outside is available on request
- Body pattern: Metallic double sealing to outside with bellows and Helicoils for D and T application with key load.
- Relief connection: A relief connection on the warm top end of the body, directly connected to the fluid space, is available on request, see catalogue no. WEKA_19910003_BodyPatterns
- Remarks: - Bigger actuators for higher shut-off pressure or lower air supply pressure available on request
- For normally open valve, type "Ps", to mount an air supply pressure control, with or without filter, is recommended to protect the valve against overload bay air pressure.

WEKA_19902010_Dimensionen-1214-48-PN25-MA_20100801-1-48-Dimensions