

THIRD ANGLE PROJECTION

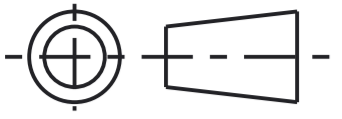

MODIFICATIONS

ISSUE	DATE	NAME	DESCRIPTION
A	Jan-21-20	G. STAVRAKIS	FIRST ISSUE

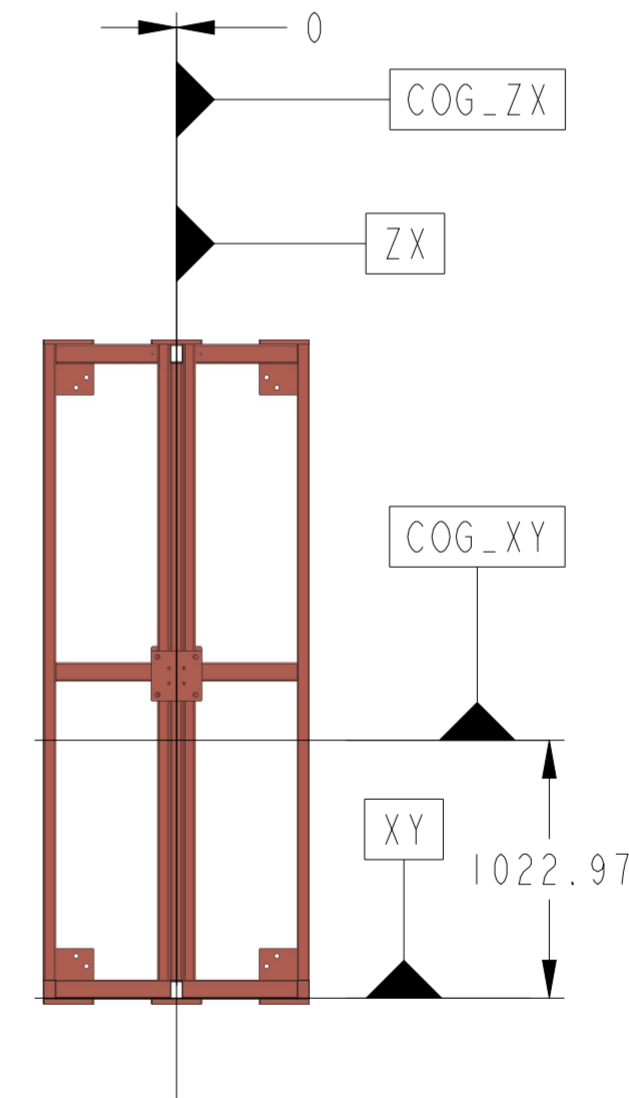
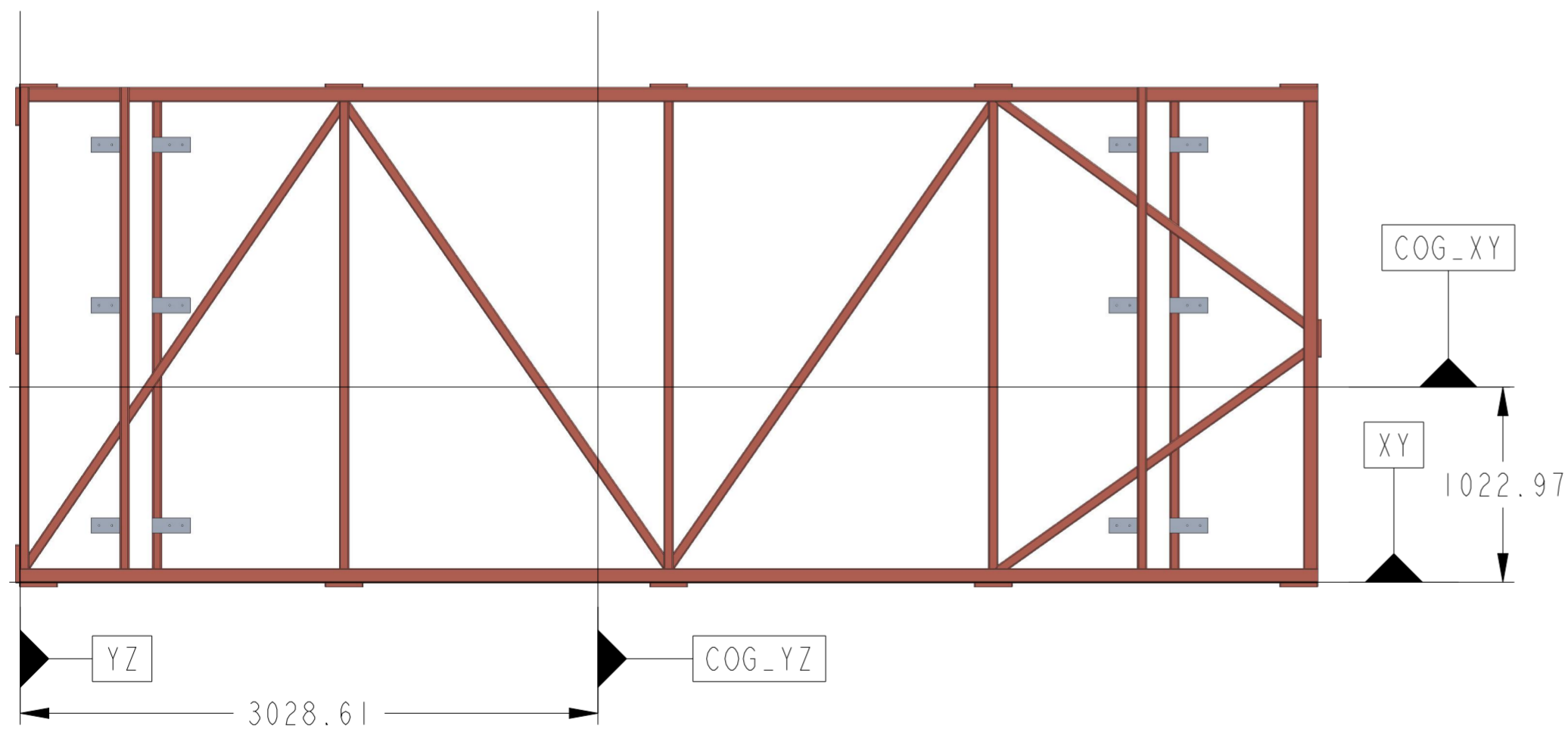
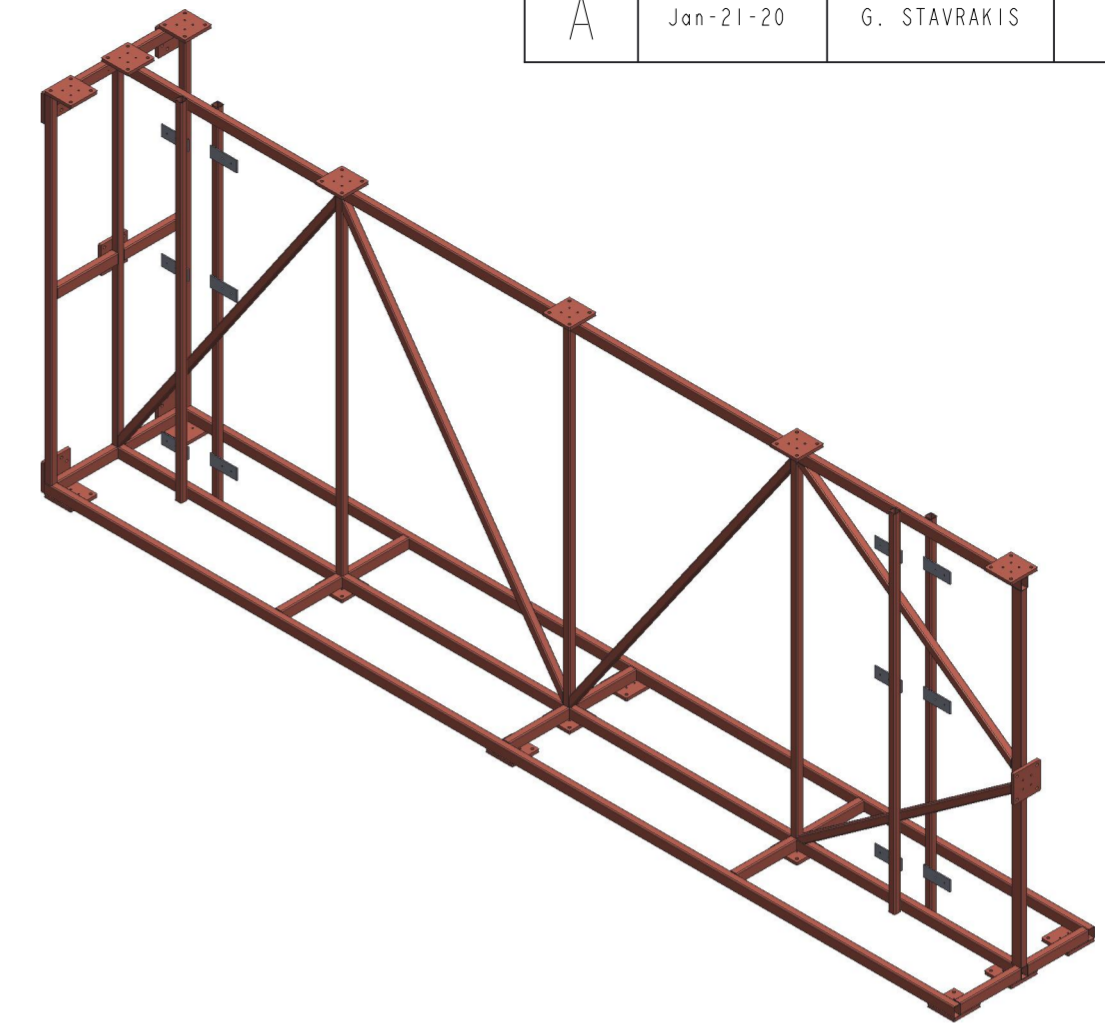
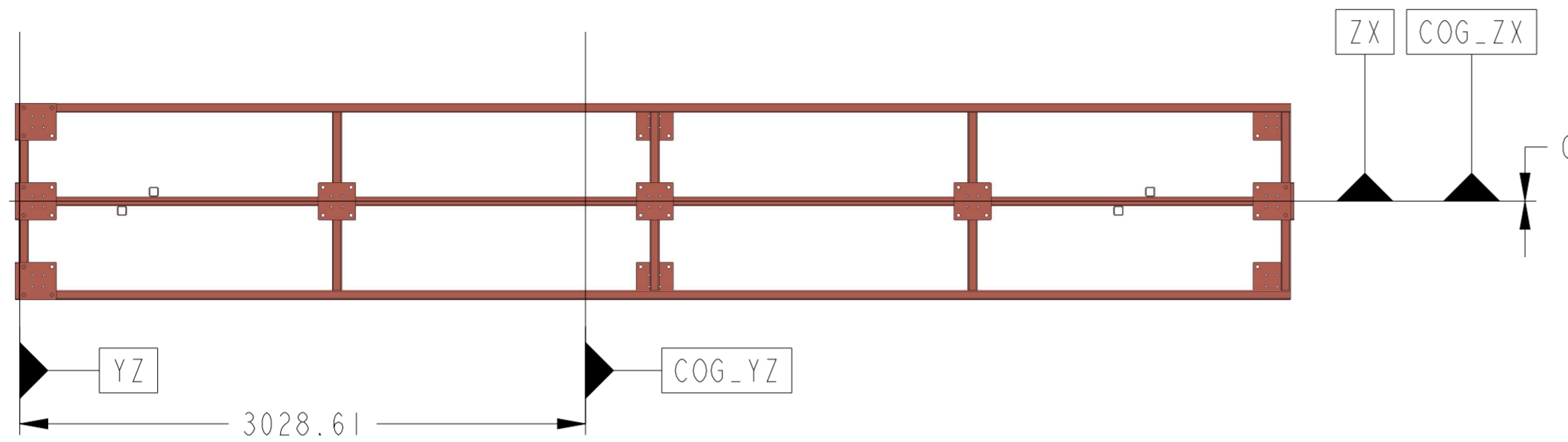

MASS CALCULATIONS	
MASS (KG)	544.453
CONTINGENCY 25% (KG)	680.566

UNLESS OTHERWISE SPECIFIED:
 ALL DIMENSIONS IN MILLIMETERS
 SURFACE TEXTURE VALUES IN MICROMETERS
 SURFACE TEXT TO BE
 MACHINE ALL OVER OR WHERE MARKED

TOLERANCES UNLESS OTHERWISE SPECIFIED		DRAWING PRACTICE AND TOLERANCE INTERPRATION TO BS 8888		WELDING SYMBOLS TO BS 2553	
MACHINED DIMS ±		MATERIAL		DRAWN	G. STAVRAKIS
ANGULAR ± °		TREATMENT		DATE	Jan-21-20
		FINISH		CHECKED	
				APPROVED	

DEPARTMENT OF PHYSICS  UNIVERSITY OF LIVERPOOL
 OLIVER LODGE BUILDING

PROJECT
 DUNE

TITLE
 FRAME ONLY WITHOUT PANELS

DRAWING NUMBER
NP79-01-40 ARRGR. DRAWING
 NP79-01

ITEM	PART/CAD No	DWG TITLE	QTY
1	NP79-01-02	CENTRAL FRAME	1

REMOVE BURRS AND BREAK SHARP EDGES	DO NOT SCALE			SHEET 1 OF 1	SCALE 1:30	A2
------------------------------------	--------------	--	--	--------------	------------	----

THIRD ANGLE PROJECTION

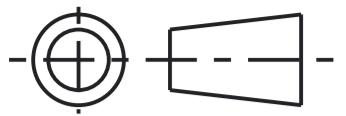

MODIFICATIONS

ISSUE	DATE	NAME	DESCRIPTION
A	Jan-21-20	G. STAVRAKIS	FIRST ISSUE

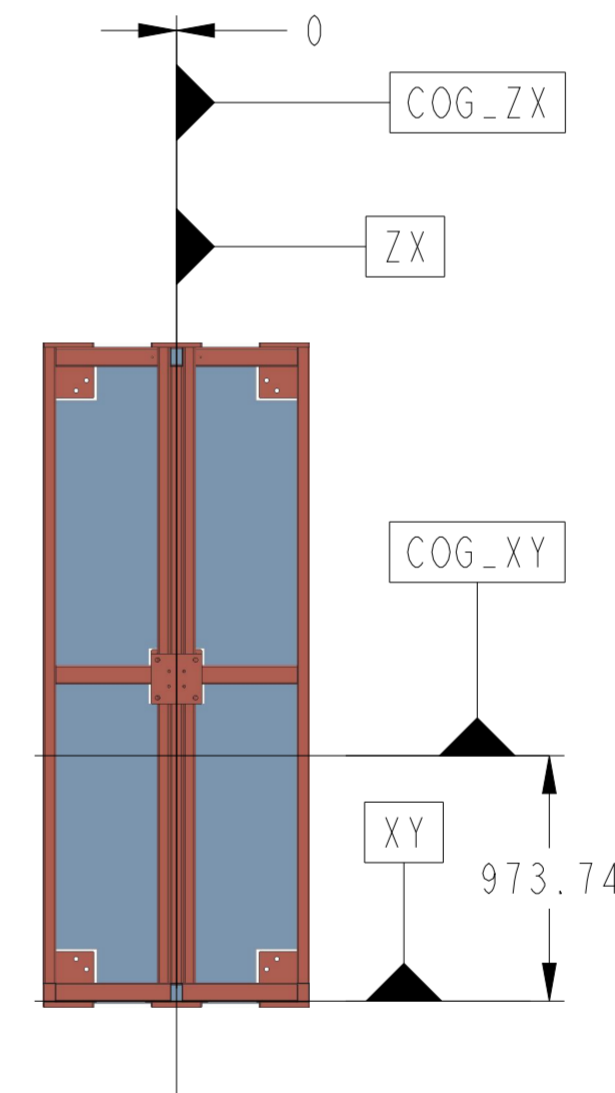
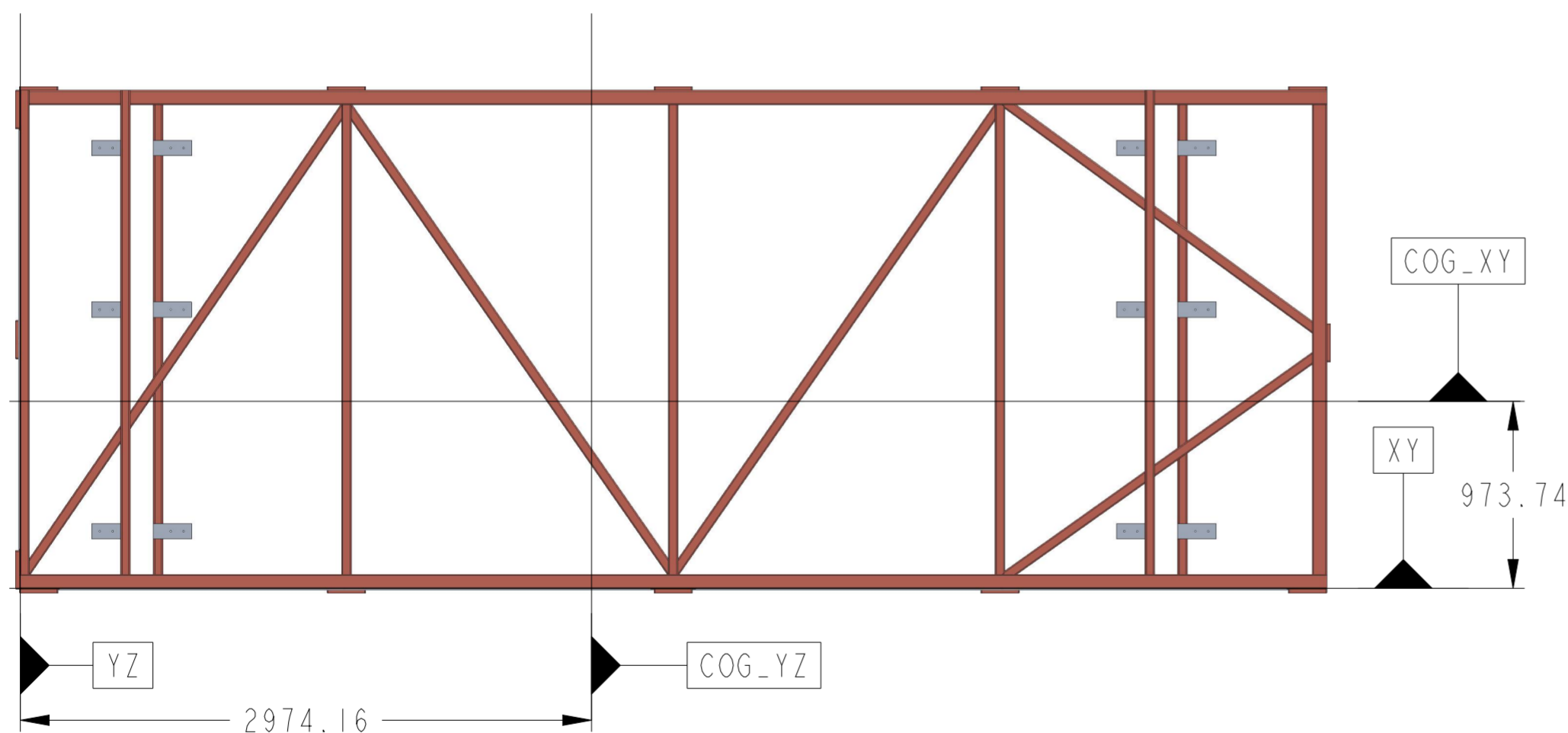
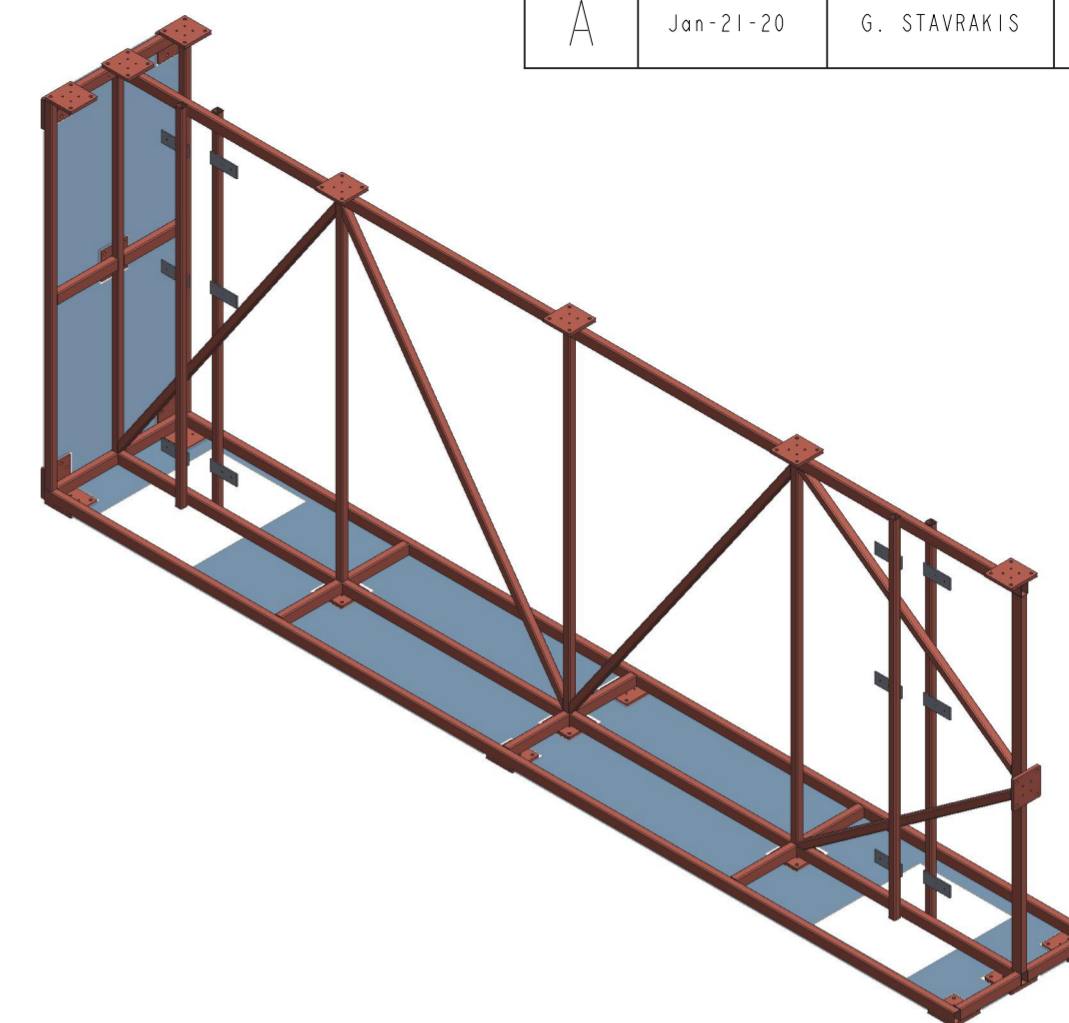
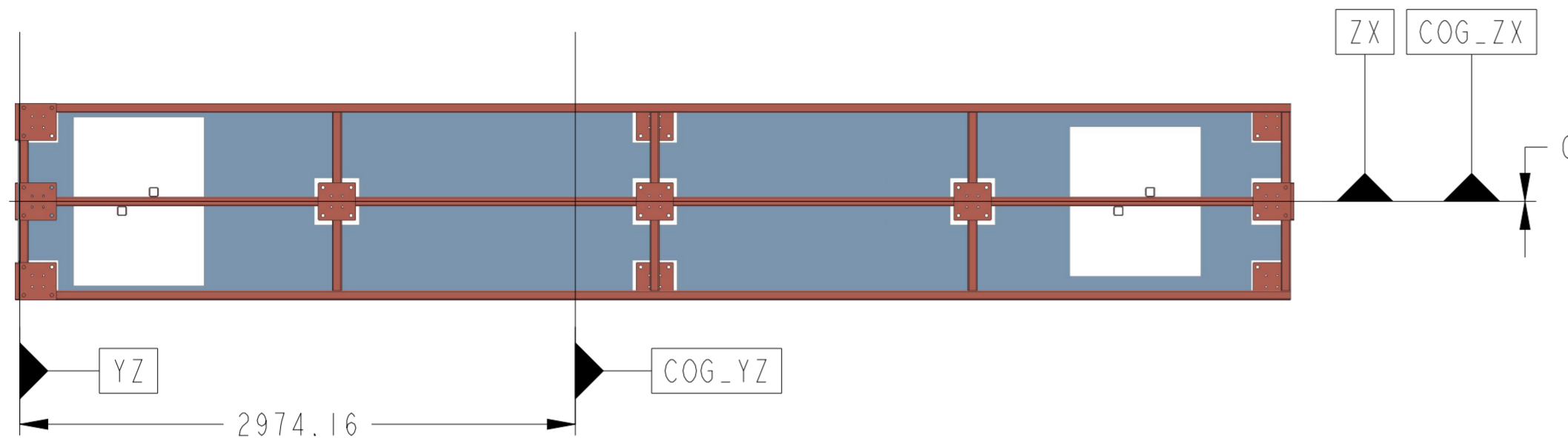

MASS CALCULATIONS	
MASS (KG)	591.655
CONTINGENCY 25% (KG)	739.569

UNLESS OTHERWISE SPECIFIED:
 ALL DIMENSIONS IN MILLIMETERS
 SURFACE TEXTURE VALUES IN MICROMETERS
 SURFACE TEXT TO BE
 MACHINE ALL OVER OR WHERE MARKED

TOLERANCES UNLESS OTHERWISE SPECIFIED		DRAWING PRACTICE AND TOLERANCE INTERPRATION TO BS 8888		WELDING SYMBOLS TO BS 2553	
MACHINED DIMS ±	SPEC	MATERIAL		DRAWN	G. STAVRAKIS
ANGULAR ± °	TREATMENT			DATE	Jan-21-20
	FINISH			CHECKED	
				APPROVED	

DEPARTMENT OF PHYSICS		UNIVERSITY OF LIVERPOOL
OLIVER LODGE BUILDING		
PROJECT		
DUNE		

TITLE		FRAME WITH PANELS
DRAWING NUMBER	NP79-01-41	ARRGR. DRAWING NP79-01
SHEET 1 OF 1	SCALE 1:30	A2

ITEM	PART/CAD No	DWG TITLE	QTY
1	NP79-01-02	CENTRAL FRAME	1

REMOVE BURRS AND BREAK SHARP EDGES

DO NOT SCALE

THIRD ANGLE PROJECTION

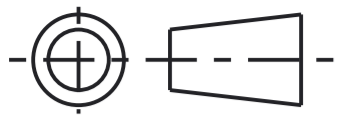

MODIFICATIONS

ISSUE	DATE	NAME	DESCRIPTION
A	Jan-21-20	G. STAVRAKIS	FIRST ISSUE

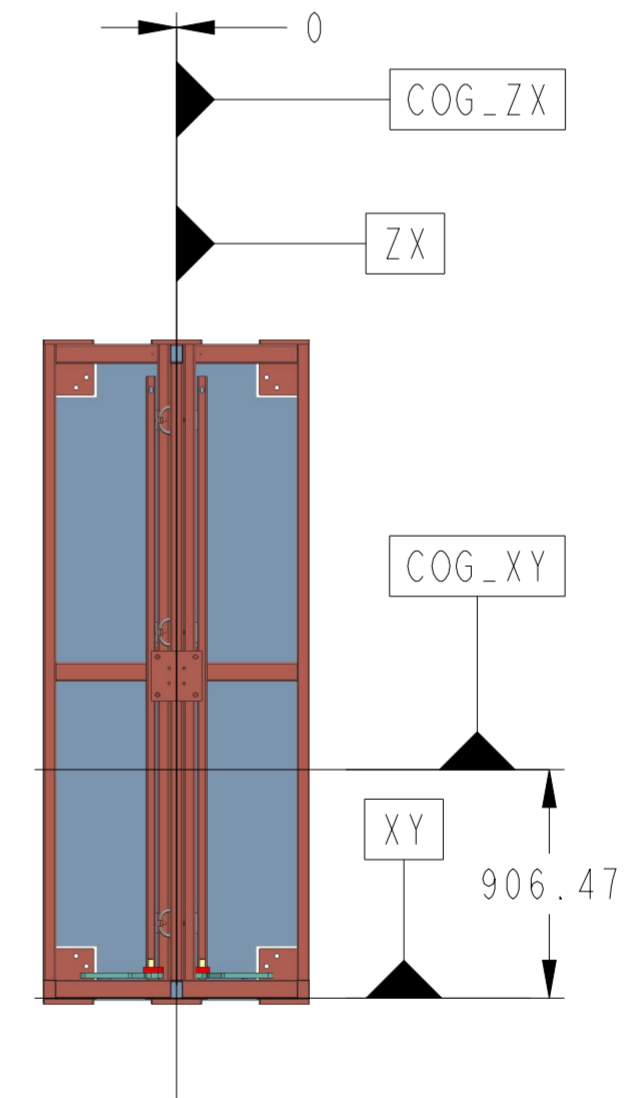
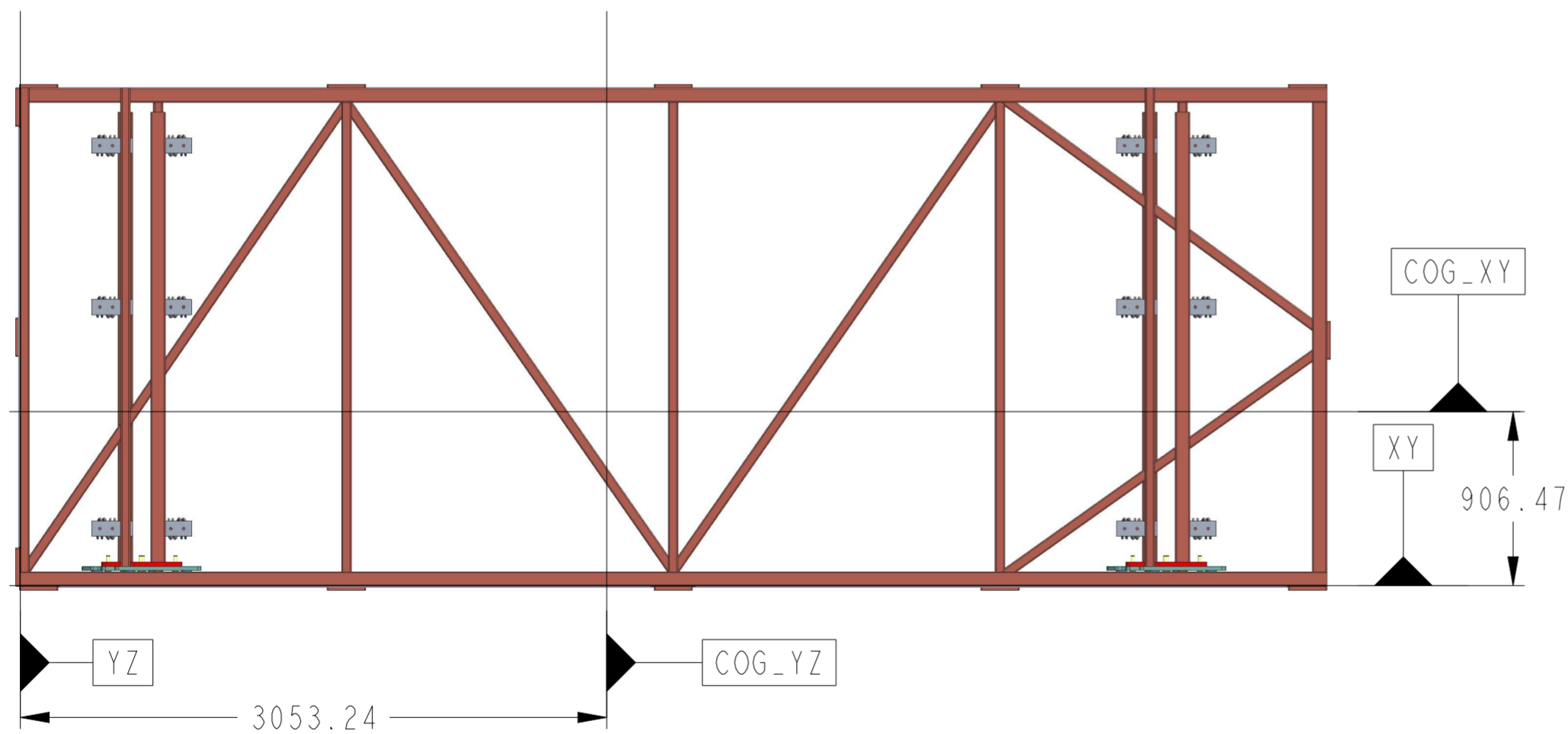
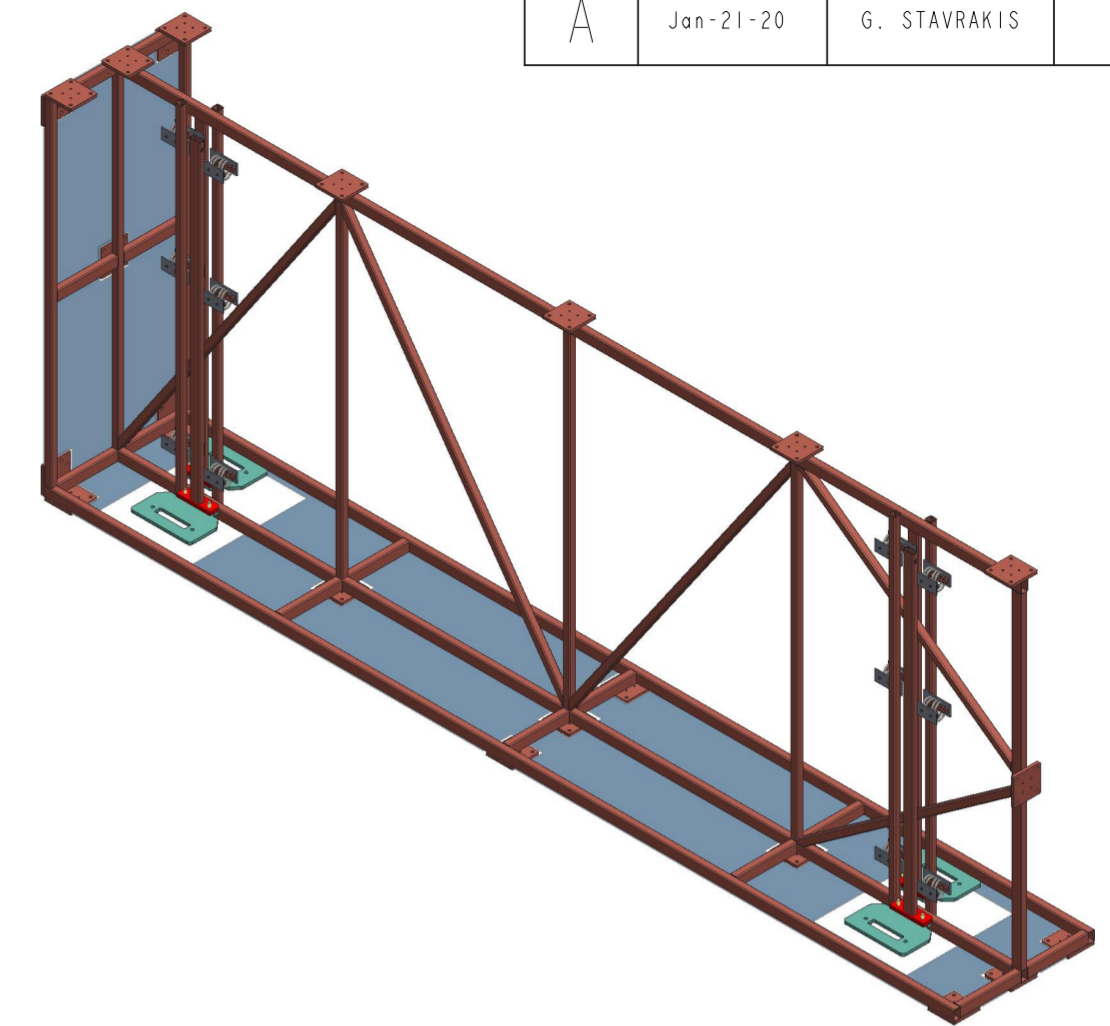
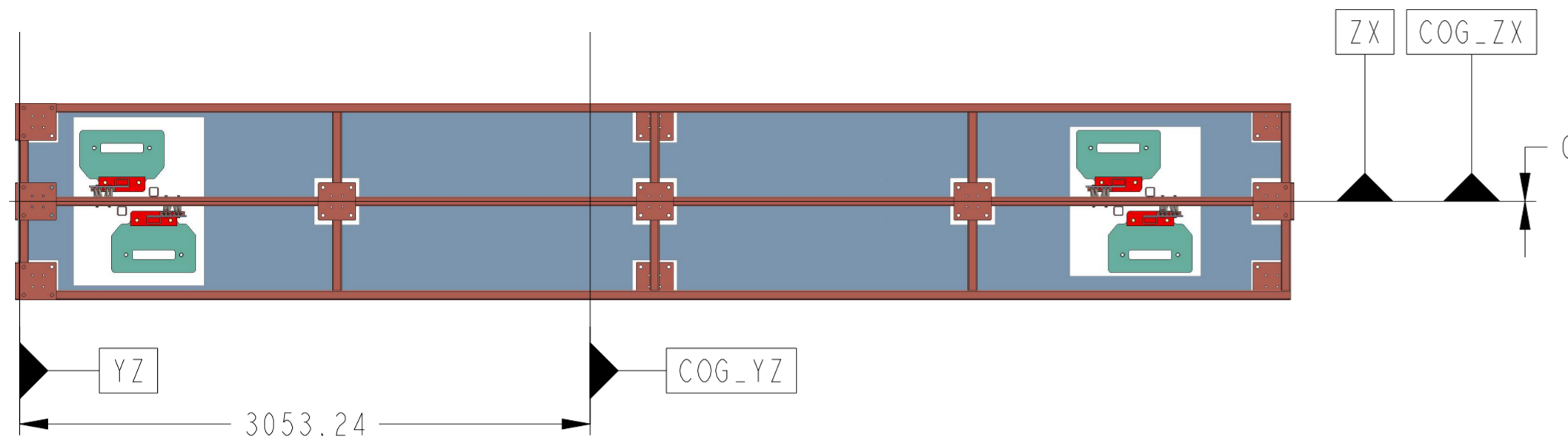

MASS CALCULATIONS	
MASS (KG)	781.245
CONTINGENCY 25% (KG)	976.556

UNLESS OTHERWISE SPECIFIED:
 ALL DIMENSIONS IN MILLIMETERS
 SURFACE TEXTURE VALUES IN MICROMETERS
 SURFACE TEXT TO BE
 MACHINE ALL OVER OR WHERE MARKED

TOLERANCES UNLESS OTHERWISE SPECIFIED		DRAWING PRACTICE AND TOLERANCE INTERPRATION TO BS 8888		WELDING SYMBOLS TO BS 2553	
MACHINED DIMS ±		MATERIAL		DRAWN	G. STAVRAKIS
ANGULAR ± °		TREATMENT		DATE	Jan-21-20
REMOVE BURRS AND BREAK SHARP EDGES	DO NOT SCALE	FINISH		CHECKED	
				APPROVED	

DEPARTMENT OF PHYSICS
 OLIVER LODGE BUILDING



PROJECT
 DUNE

TITLE
 FRAME WITH PANELS AND ATTACHMENT

DRAWING NUMBER
NP79-01-42

SHEET 1 OF 1
 SCALE 1:30
 ARRGR. DRAWING
 NP79-01
 A2

ITEM	PART/CAD No	DWG TITLE	QTY
1	NP79-01-02	CENTRAL FRAME	1

THIRD ANGLE PROJECTION

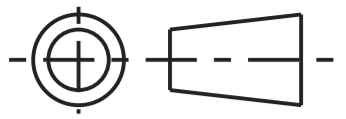

MODIFICATIONS

ISSUE	DATE	NAME	DESCRIPTION
A	Jan-21-20	G. STAVRAKIS	FIRST ISSUE

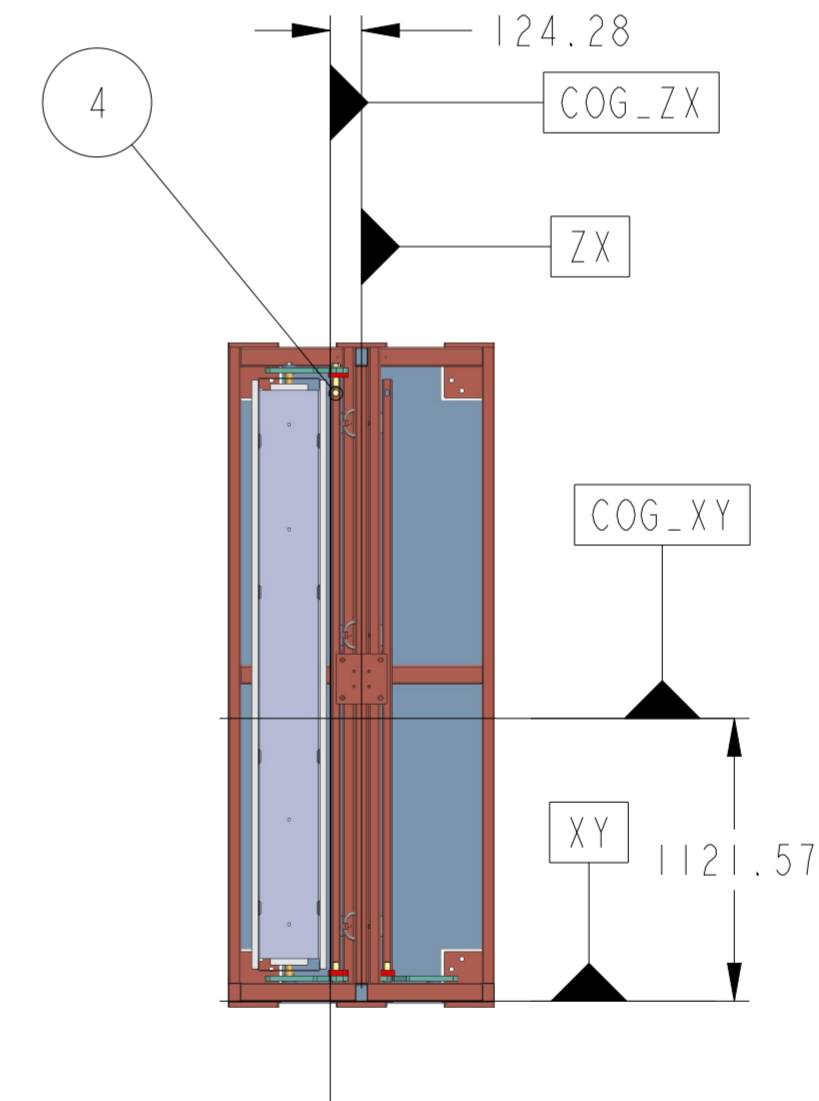
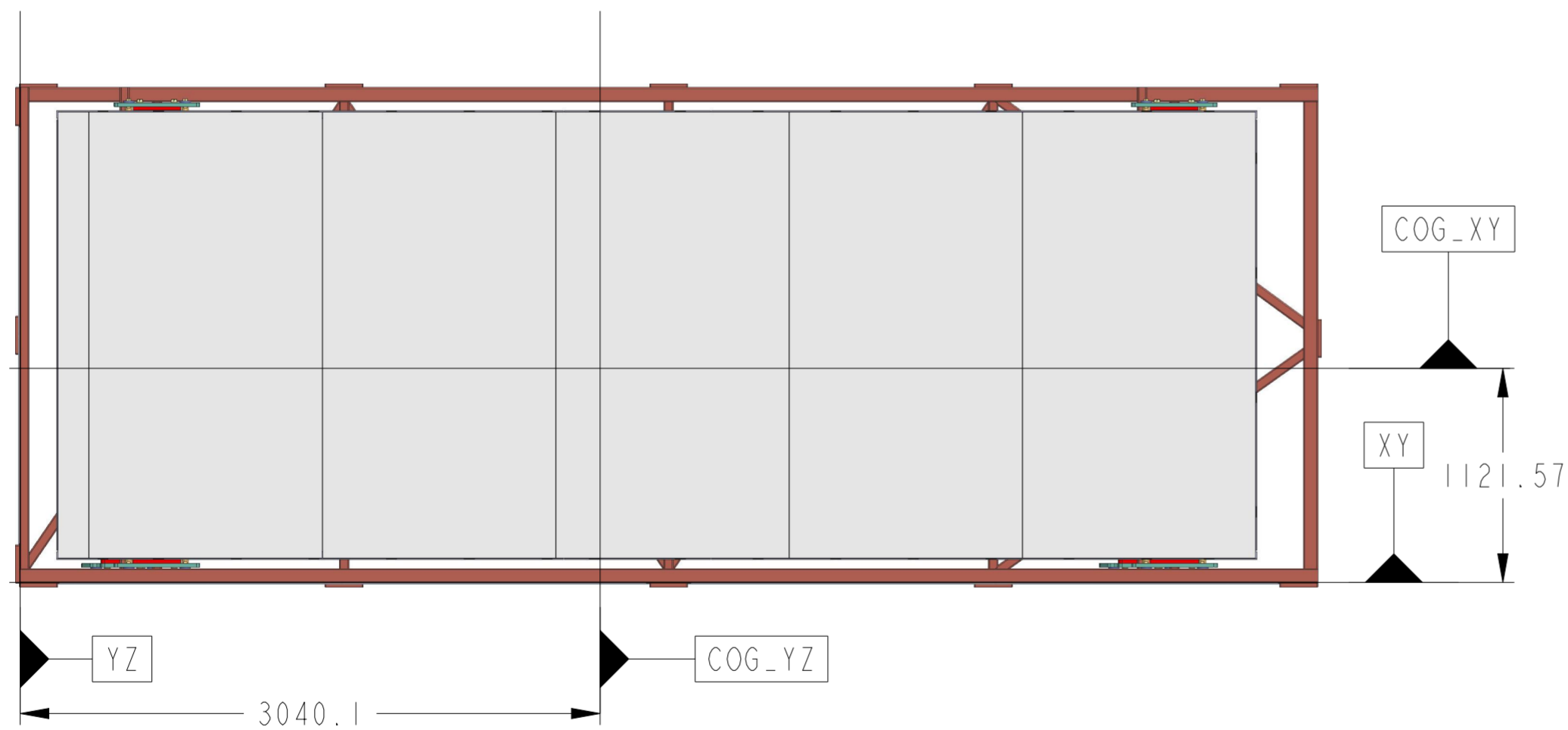
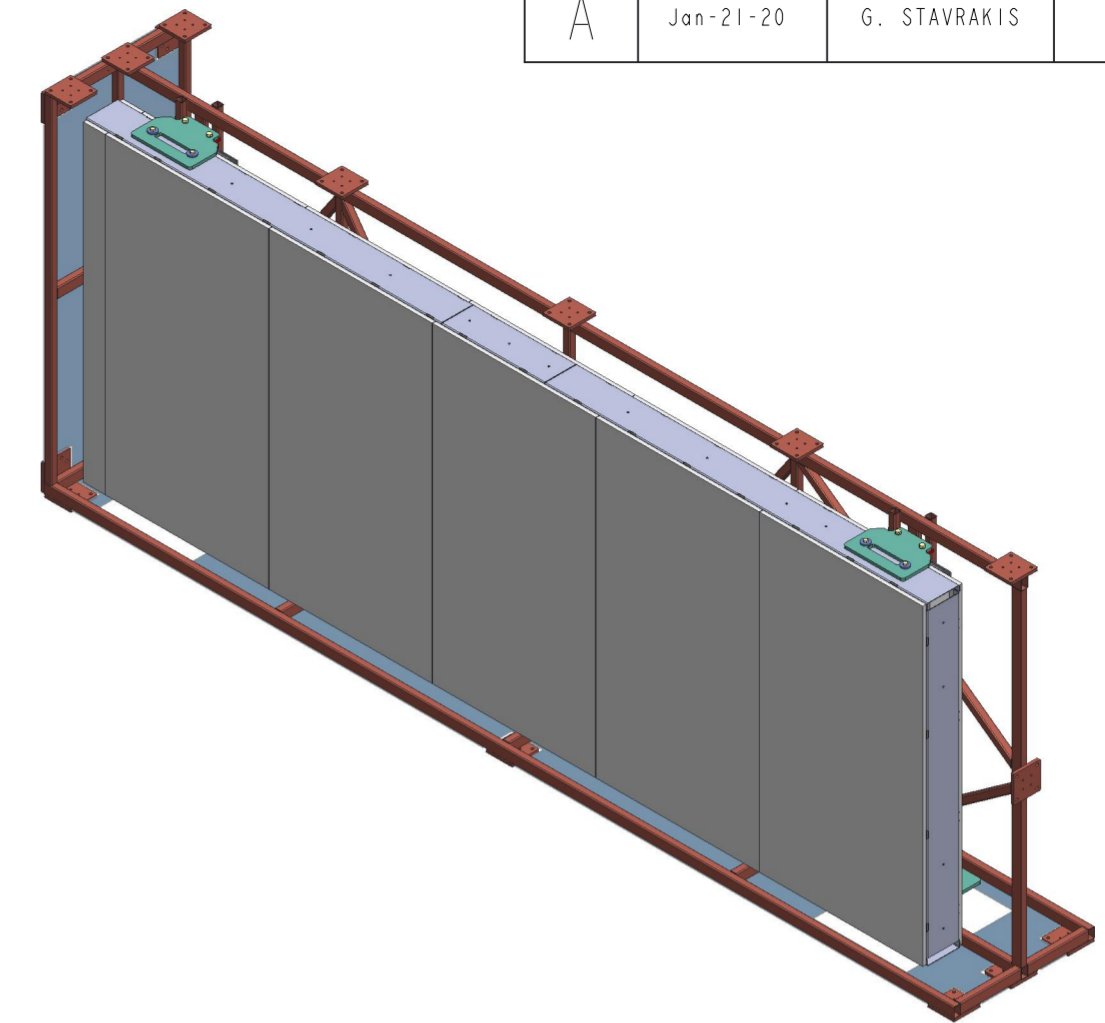
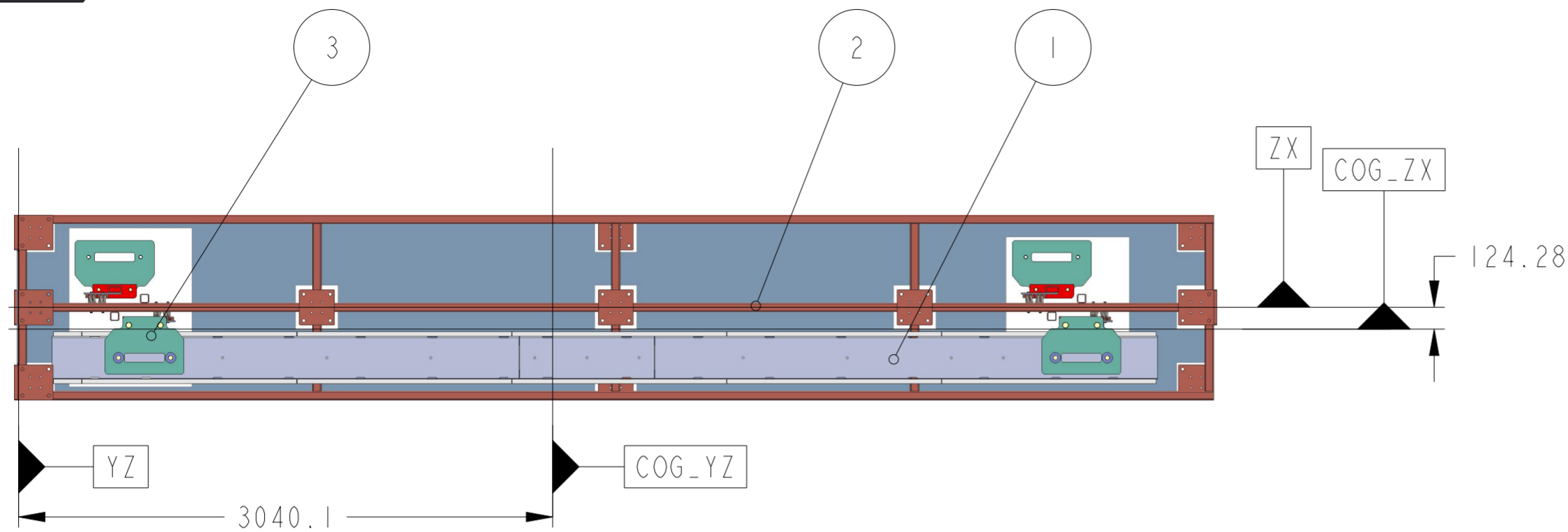

MASS CALCULATIONS	
MASS (KG)	1405.970
CONTINGENCY 25% (KG)	1757.463

ITEM	PART/CAD No	DWG TITLE	QTY
1	NP79-01-97	BOTTOM APA	1
2	NP79-01-02	CENTRAL FRAME	1
3	NP79-01-04	TOP ATTACHMENT ASSEMBLY	2
4	M16_SET		2

UNLESS OTHERWISE SPECIFIED: ALL DIMENSIONS IN MILLIMETERS SURFACE TEXTURE VALUES IN MICROMETERS SURFACE TEXT TO BE MACHINE ALL OVER OR WHERE MARKED ✓	METRIC SCREW THREADS TO BS3643 CLASS 6H/6g	DRAWING PRACTICE AND TOLERANCE INTERPRATION TO BS 8888	WELDING SYMBOLS TO BS 2553	
	TOLERANCES UNLESS OTHERWISE SPECIFIED	MATERIAL	DRAWN	G. STAVRAKIS
	MACHINED DIMS ±	SPEC	DATE	Jan-21-20
	ANGULAR ± °	TREATMENT	CHECKED	
REMOVE BURRS AND BREAK SHARP EDGES	DO NOT SCALE	FINISH	APPROVED	

DEPARTMENT OF PHYSICS		UNIVERSITY OF LIVERPOOL	
OLIVER LODGE BUILDING			
PROJECT			
DUNE			
TITLE			
FRAME WITH ONE APA INSTALLED			
DRAWING NUMBER		ARRGR. DRAWING	
NP79-01-43		NP79-01	
SHEET 1 OF 1		SCALE 1:30	
		A2	

THIRD ANGLE PROJECTION

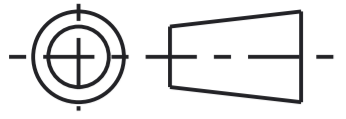

MODIFICATIONS

ISSUE	DATE	NAME	DESCRIPTION
A	Jan-21-20	G. STAVRAKIS	FIRST ISSUE

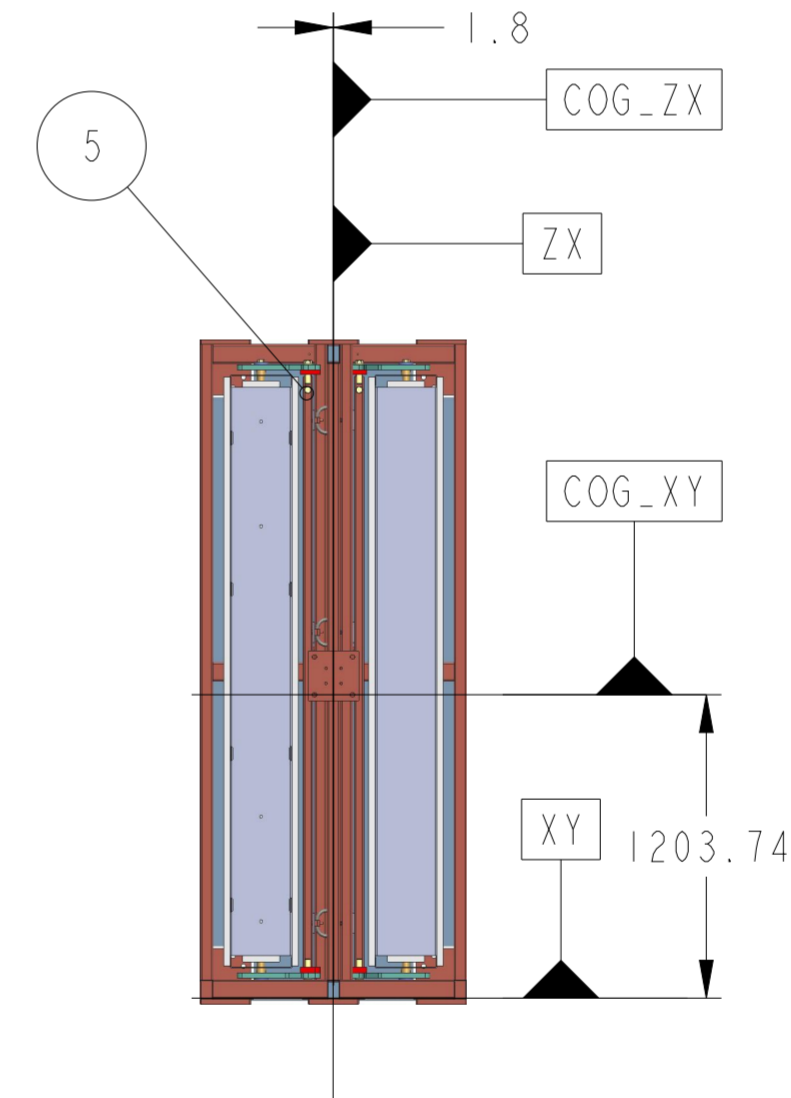
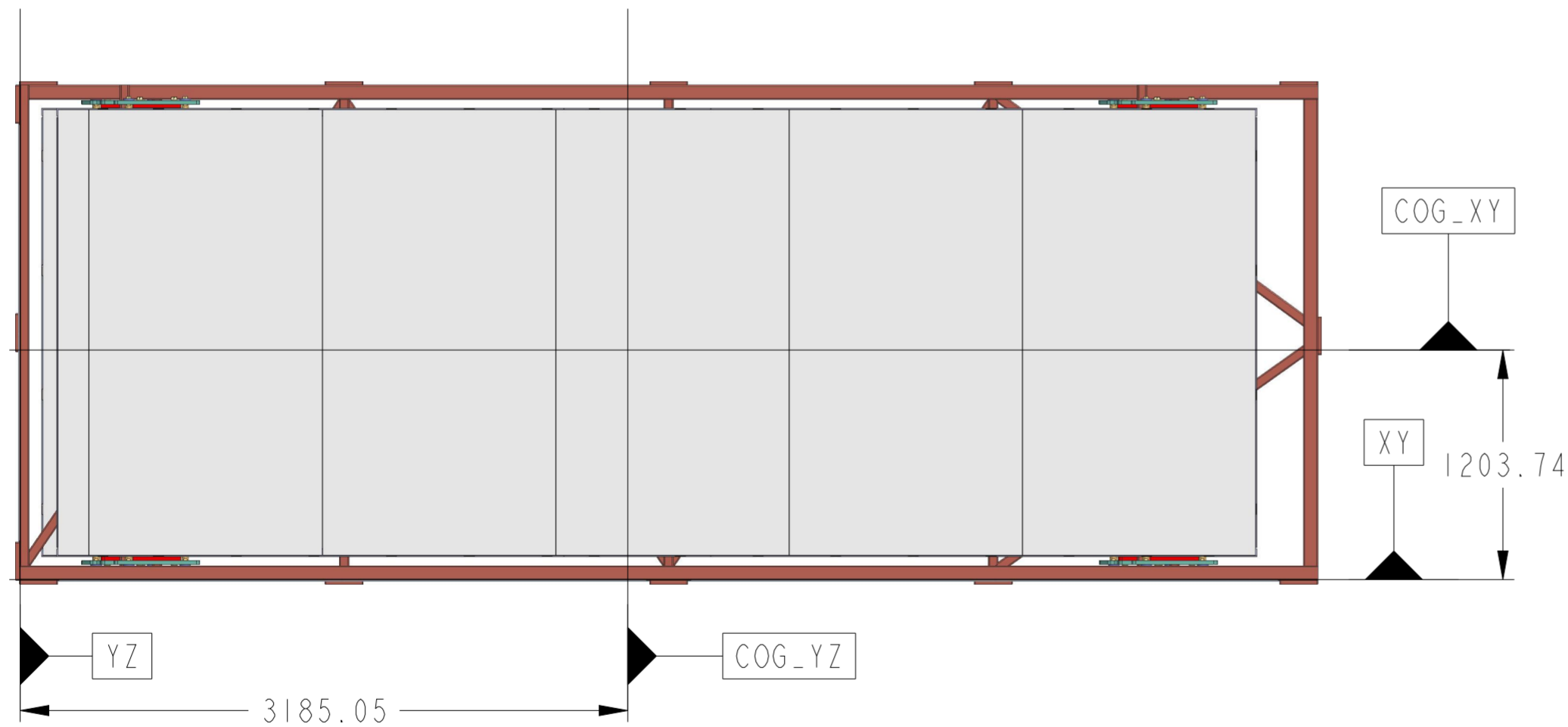
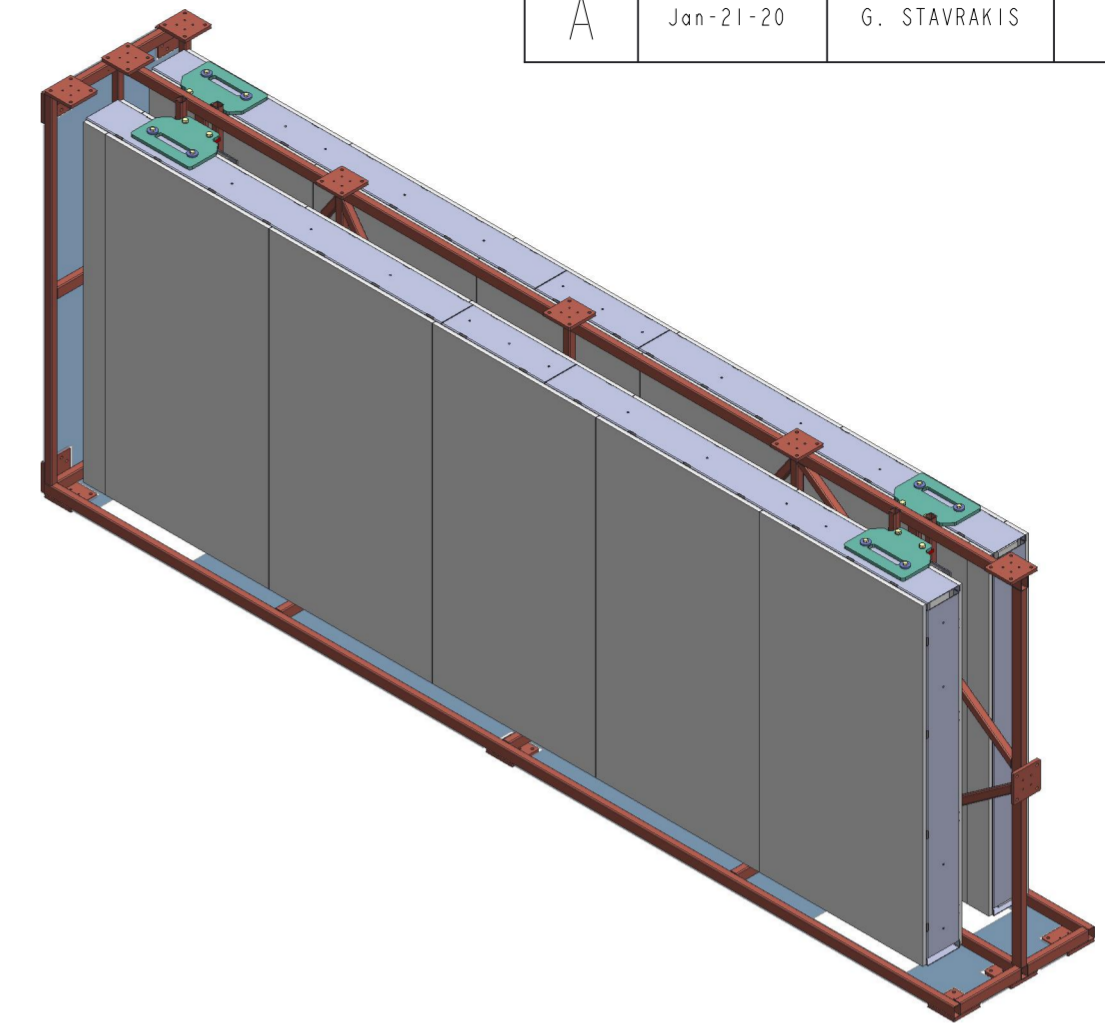
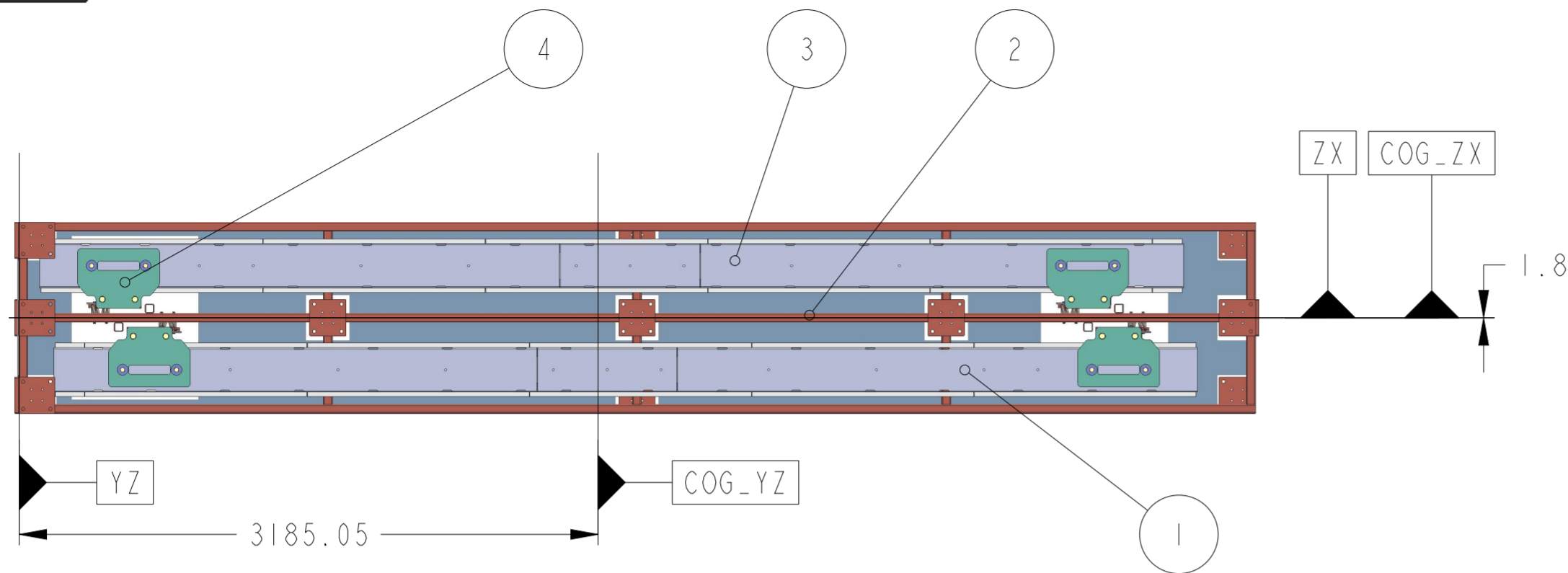

MASS CALCULATIONS	
MASS (KG)	2018.001
CONTINGENCY 25% (KG)	2522.501

ITEM	PART/CAD No	DWG TITLE	QTY
1	NP79-01-97	BOTTOM APA	1
2	NP79-01-02	CENTRAL FRAME	1
3	NP79-01-98	TOP APA	1
4	NP79-01-04	TOP ATTACHMENT ASSEMBLY	4
5	M16_SET		4

UNLESS OTHERWISE SPECIFIED: _	METRIC SCREW THREADS TO BS3643 CLASS 6H/6g	DRAWING PRACTICE AND TOLERANCE INTERPRATION TO BS 8888	WELDING SYMBOLS TO BS 2553
ALL DIMENSIONS IN MILLIMETERS	TOLERANCES UNLESS OTHERWISE SPECIFIED	MATERIAL	DRAWN G. STAVRAKIS
SURFACE TEXTURE VALUES IN MICROMETERS	MACHINED DIMS ±	SPEC	DATE Jan-21-20
SURFACE TEXT TO BE MACHINE ALL OVER OR WHERE MARKED ✓	ANGULAR ± °	TREATMENT	CHECKED
REMOVE BURRS AND BREAK SHARP EDGES	DO NOT SCALE	FINISH	APPROVED

DEPARTMENT OF PHYSICS		UNIVERSITY OF LIVERPOOL
OLIVER LODGE BUILDING		PROJECT
DUNE		
TITLE		
FRAME WITH BOTH APAs INSTALLED		
DRAWING NUMBER		ARRGR. DRAWING
NP79-01-44		NP79-01
SHEET 1 OF 1	SCALE 1:30	A2

THIRD ANGLE PROJECTION

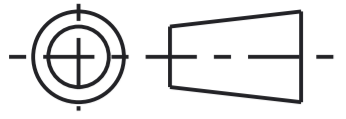

MODIFICATIONS

ISSUE	DATE	NAME	DESCRIPTION
A	Jan-21-20	G. STAVRAKIS	FIRST ISSUE

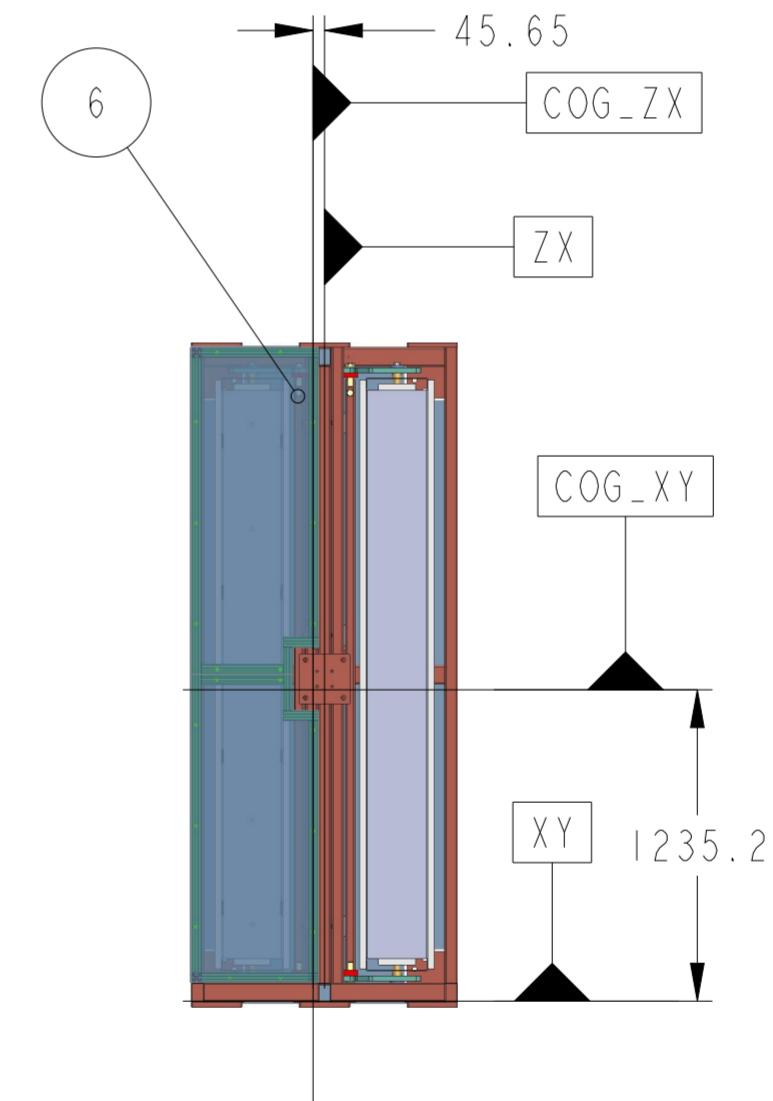
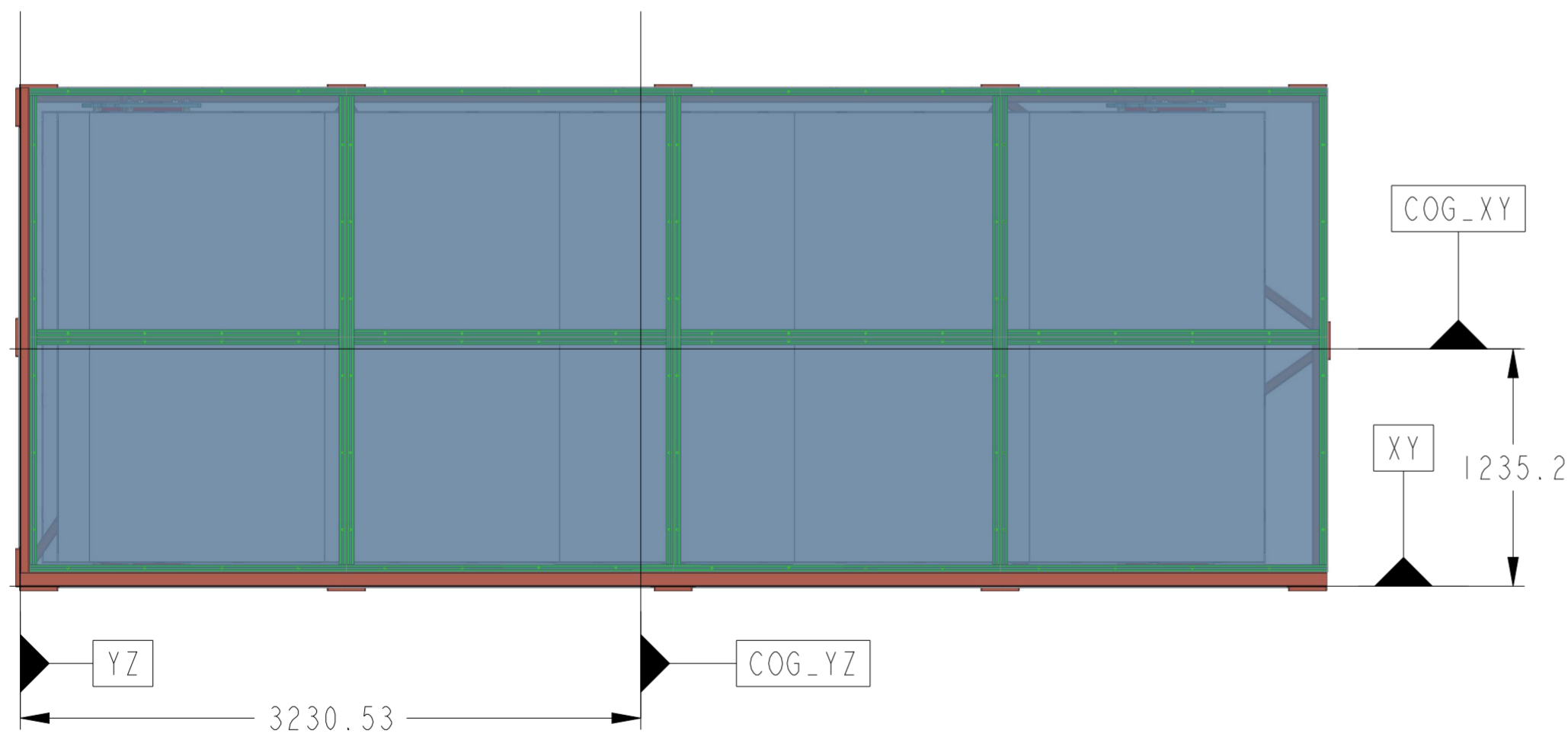
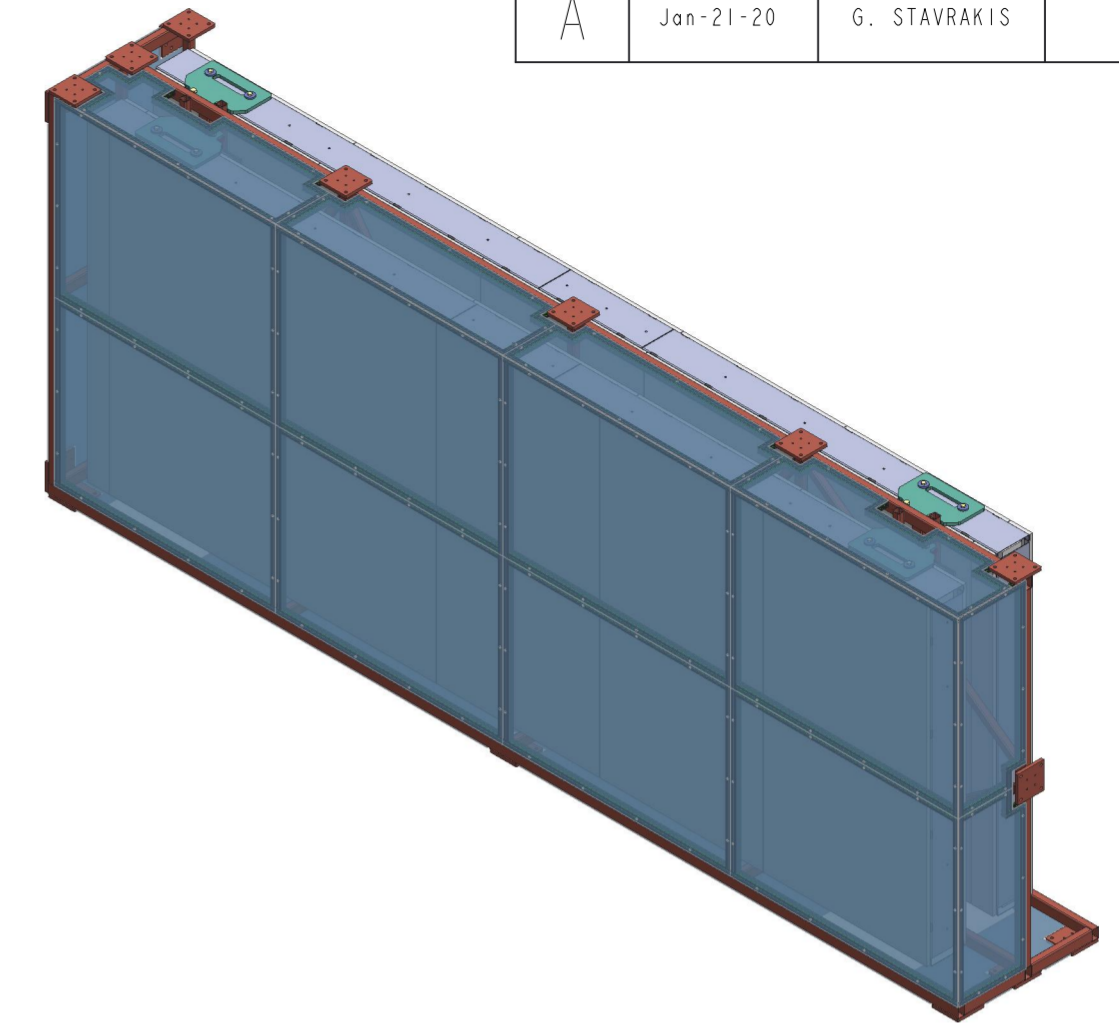
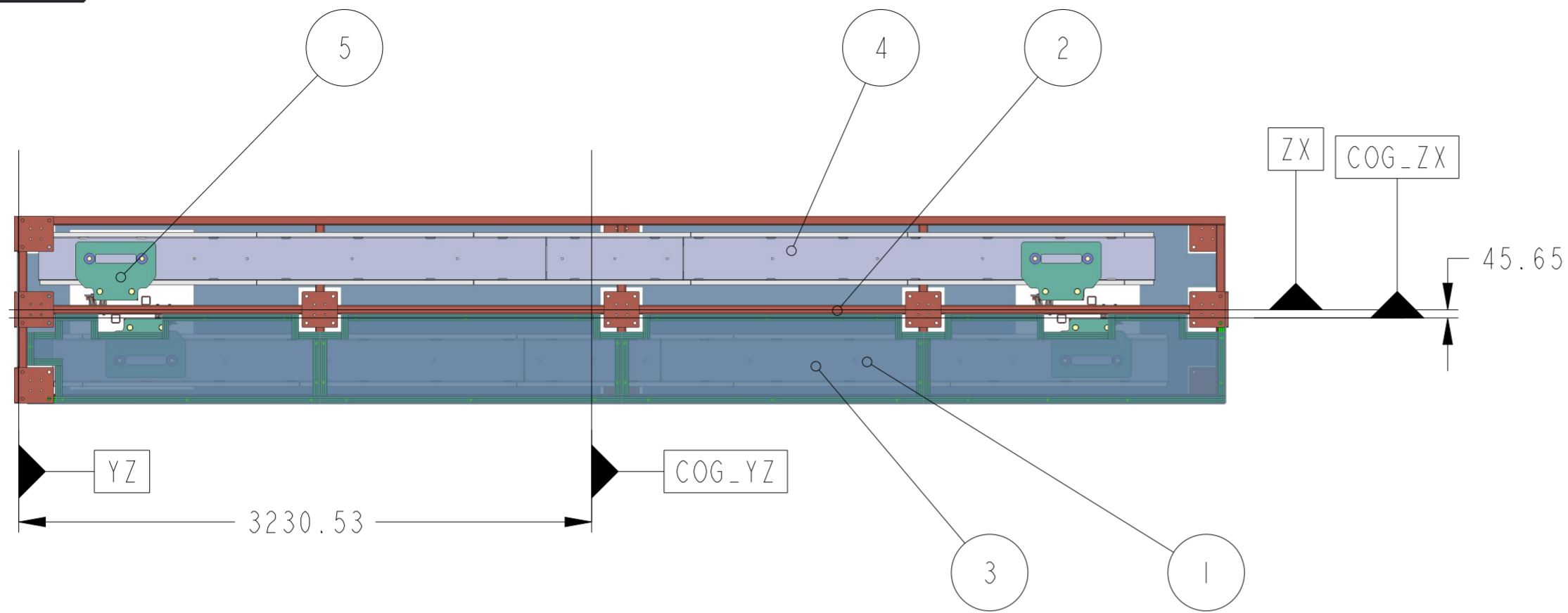

ITEM	PART/CAD No	DWG TITLE	QTY
1	NP79-01-97	BOTTOM APA	1
2	NP79-01-02	CENTRAL FRAME	1
3	NP79-01-07	SIDE FRAME	1
4	NP79-01-98	TOP APA	1
5	NP79-01-04	TOP ATTACHMENT ASSEMBLY	4
6	M16_SET		4

MASS CALCULATIONS	
MASS (KG)	2237.678
CONTINGENCY 25% (KG)	2797.098

UNLESS OTHERWISE SPECIFIED:
 ALL DIMENSIONS IN MILLIMETERS
 SURFACE TEXTURE VALUES IN MICROMETERS
 SURFACE TEXT TO BE
 MACHINE ALL OVER OR WHERE MARKED

TOLERANCES UNLESS OTHERWISE SPECIFIED	MATERIAL	DRAWING PRACTICE AND TOLERANCE INTERPRATION TO BS 8888	WELDING SYMBOLS TO BS 2553
MACHINED DIMS ±	SPEC		DRAWN G. STAVRAKIS
ANGULAR ± °	TREATMENT		DATE Jan-21-20
REMOVE BURRS AND BREAK SHARP EDGES	FINISH		CHECKED
DO NOT SCALE			APPROVED

DEPARTMENT OF PHYSICS		UNIVERSITY OF LIVERPOOL	
OLIVER LODGE BUILDING			
PROJECT DUNE			
TITLE BOTH APAs INSTALLED ONE SIDE FRAME			
DRAWING NUMBER		ARRGR. DRAWING	
NP79-01-45		NP79-01	
SHEET 1 OF 1		SCALE 1:30	
		A2	

THIRD ANGLE PROJECTION

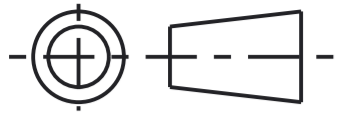

MODIFICATIONS			
ISSUE	DATE	NAME	DESCRIPTION
A	Jan-21-20	G. STAVRAKIS	FIRST ISSUE

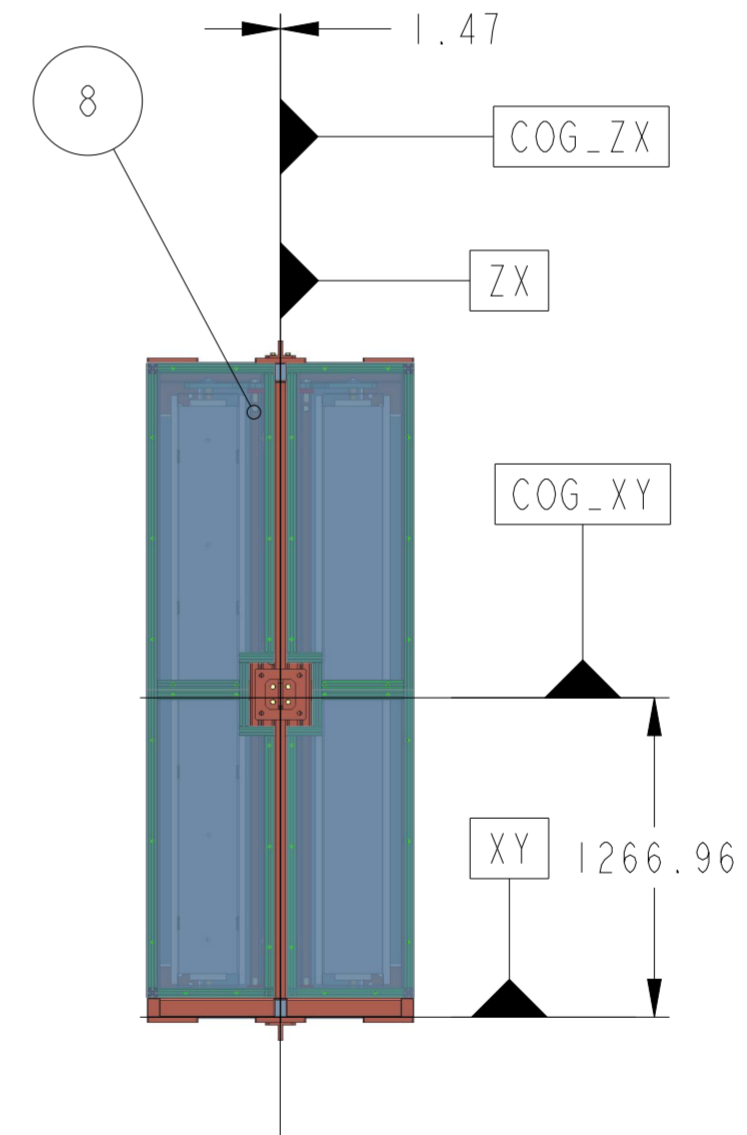
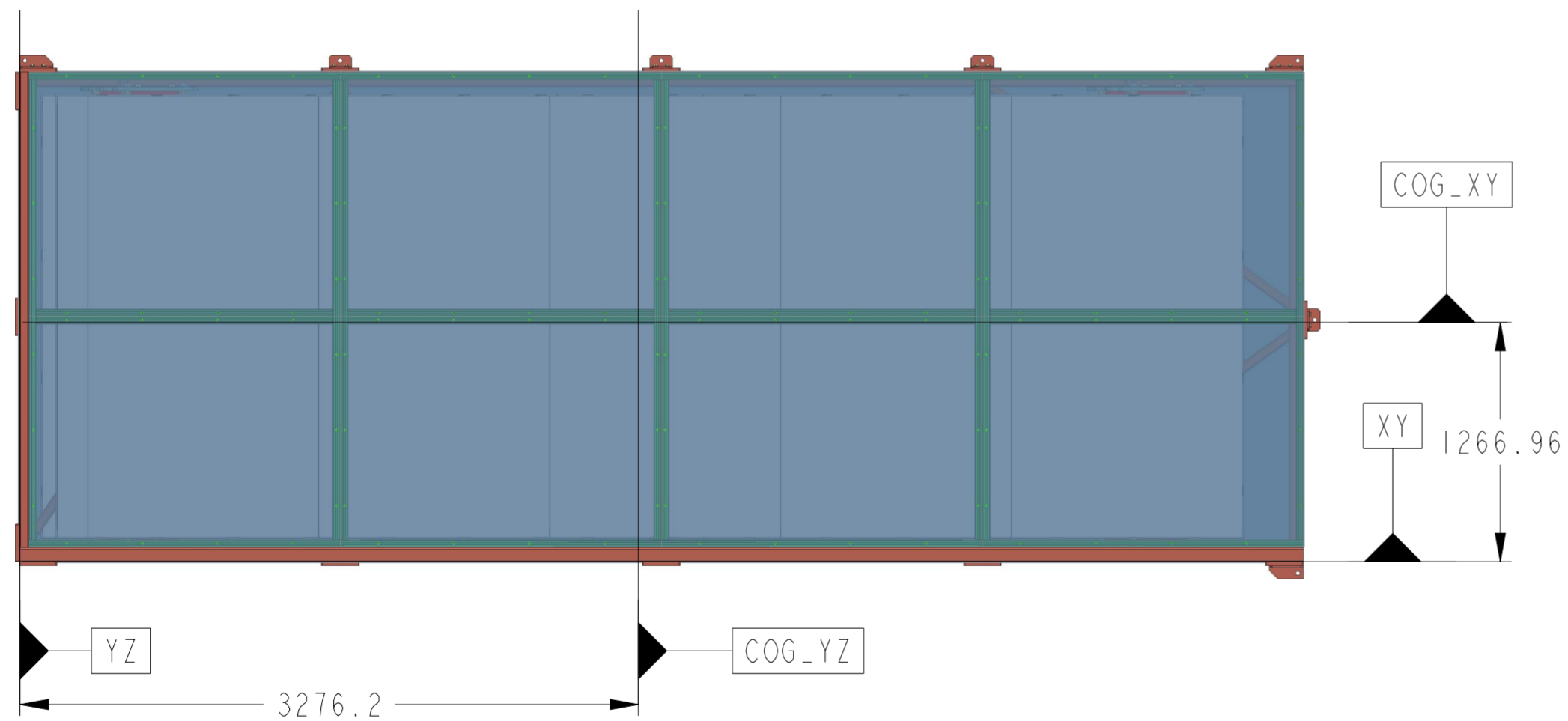
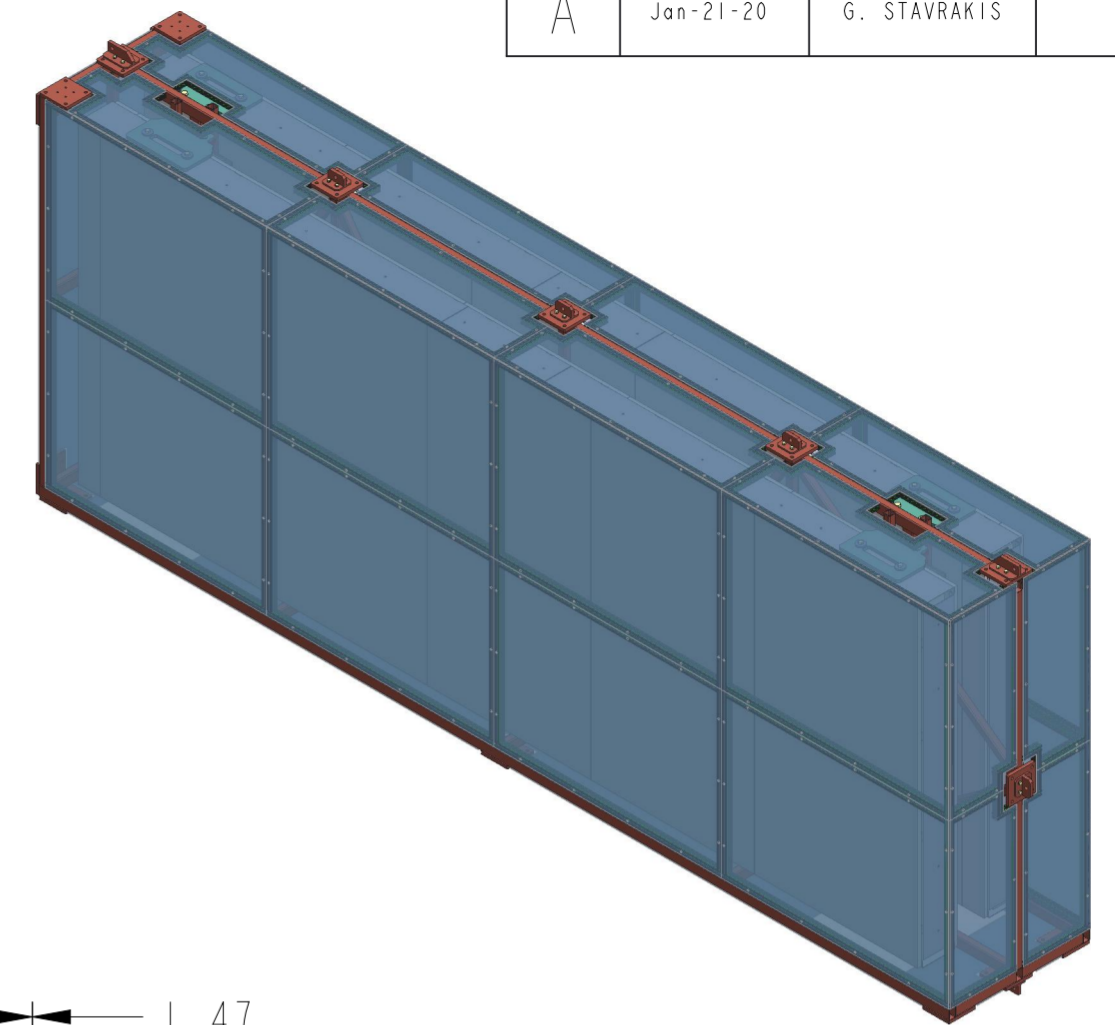
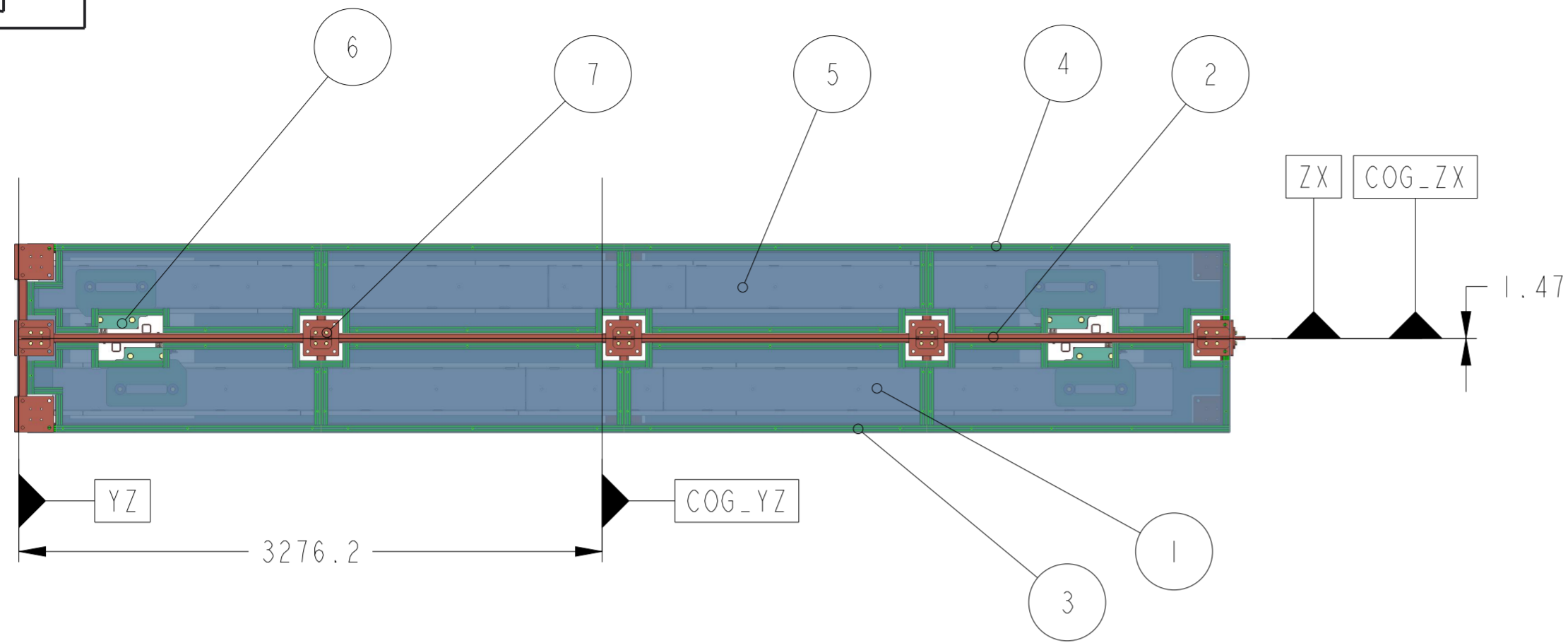

ITEM	PART/CAD No	DWG TITLE	QTY
1	NP79-01-97	BOTTOM APA	1
2	NP79-01-02	CENTRAL FRAME	1
3	NP79-01-07	SIDE FRAME	1
4	NP79-01-08	SIDE FRAME	1
5	NP79-01-98	TOP APA	1
6	NP79-01-04	TOP ATTACHMENT ASSEMBLY	4
7	MI2_SET		24
8	MI6_SET		4

MASS CALCULATIONS	
MASS (KG)	2476.326
CONTINGENCY 25% (KG)	3095.408

UNLESS OTHERWISE SPECIFIED: .	METRIC SCREW THREADS TO BS3643 CLASS 6H/6g	DRAWING PRACTICE AND TOLERANCE INTERPRATION TO BS 8888	WELDING SYMBOLS TO BS 2553
ALL DIMENSIONS IN MILLIMETERS	TOLERANCES UNLESS OTHERWISE SPECIFIED	MATERIAL	DRAWN G. STAVRAKIS
SURFACE TEXTURE VALUES IN MICROMETERS	MACHINED DIMS ±	SPEC	DATE Jan-21-20
SURFACE TEXT TO BE MACHINE ALL OVER OR WHERE MARKED ✓	ANGULAR ± °	TREATMENT	CHECKED
REMOVE BURRS AND BREAK SHARP EDGES	DO NOT SCALE	FINISH	APPROVED

DEPARTMENT OF PHYSICS		UNIVERSITY OF LIVERPOOL	
OLIVER LODGE BUILDING			
PROJECT DUNE			
TITLE BOTH APAs INSTALLED BOTH SIDE FRAMES			
DRAWING NUMBER NP79-01-46		ARRGR. DRAWING NP79-01	
SHEET 1 OF 1		SCALE 1:30	

THIRD ANGLE PROJECTION

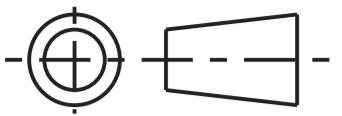

MODIFICATIONS

ISSUE	DATE	NAME	DESCRIPTION
A	Jan-21-20	G. STAVRAKIS	FIRST ISSUE

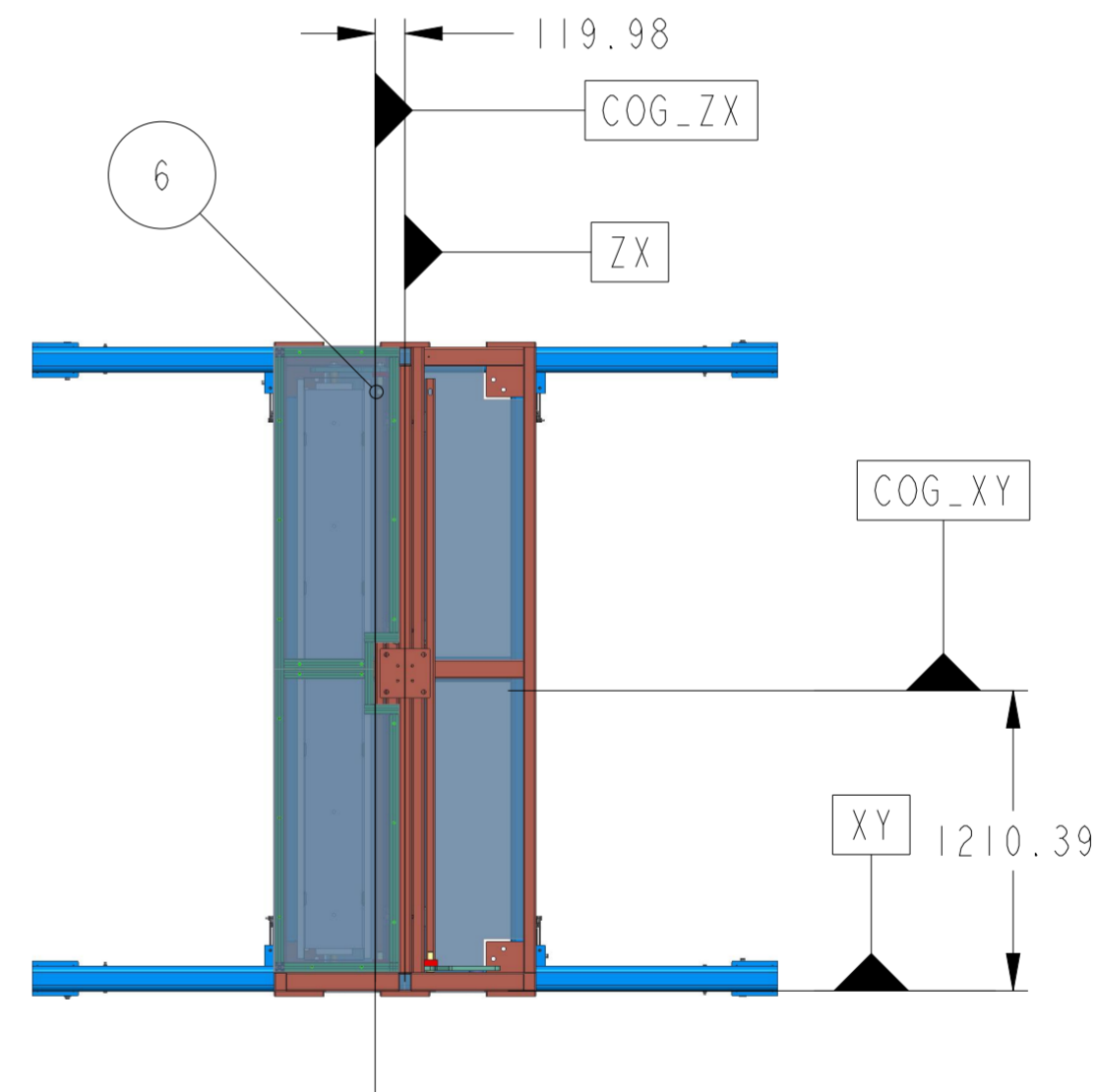
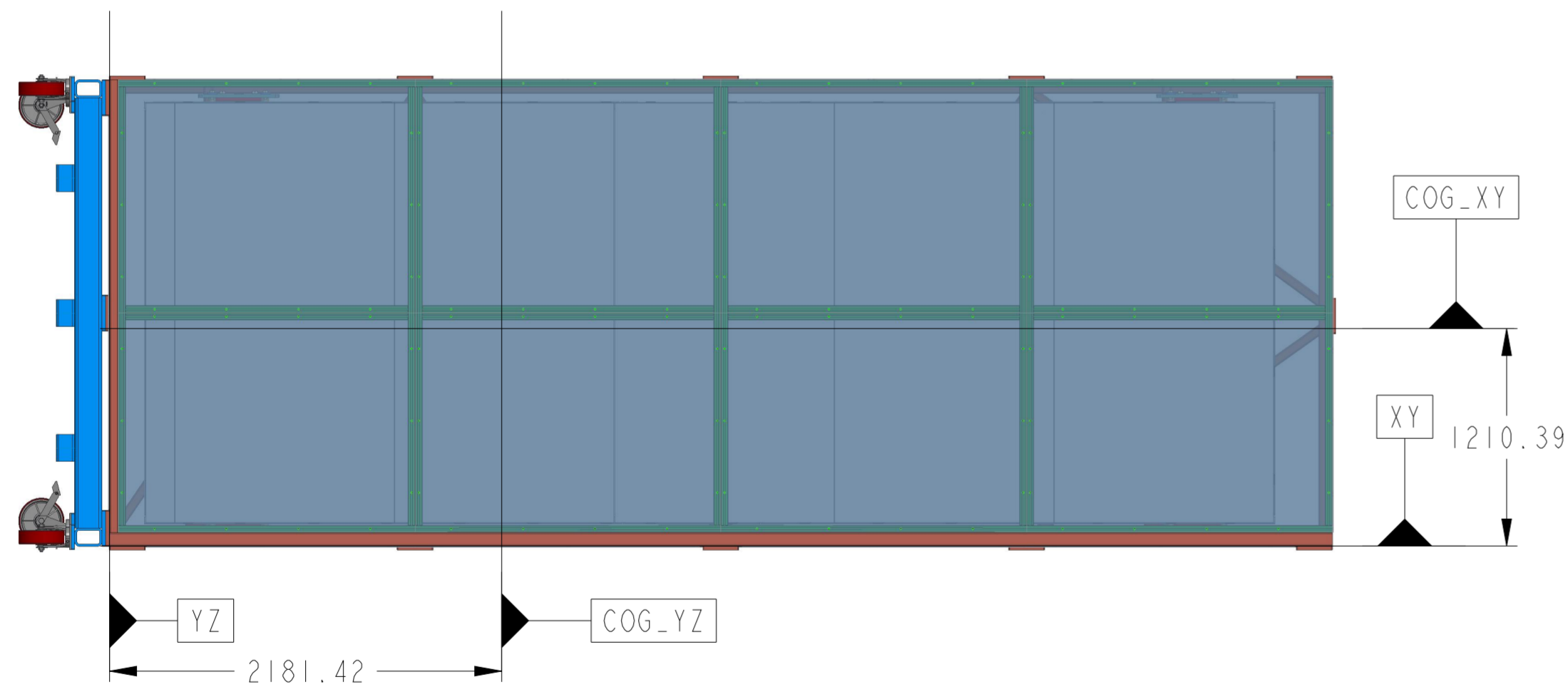
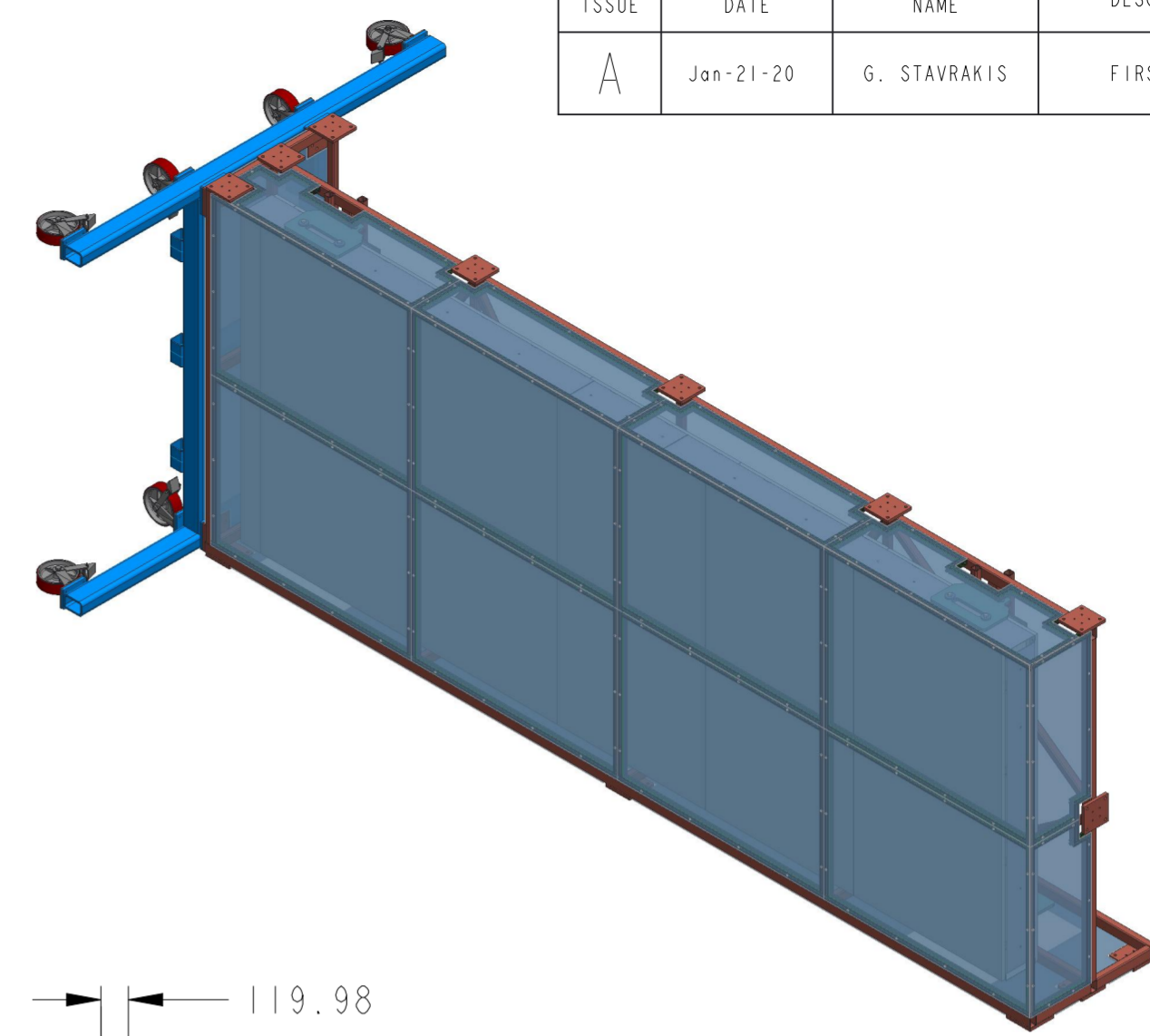
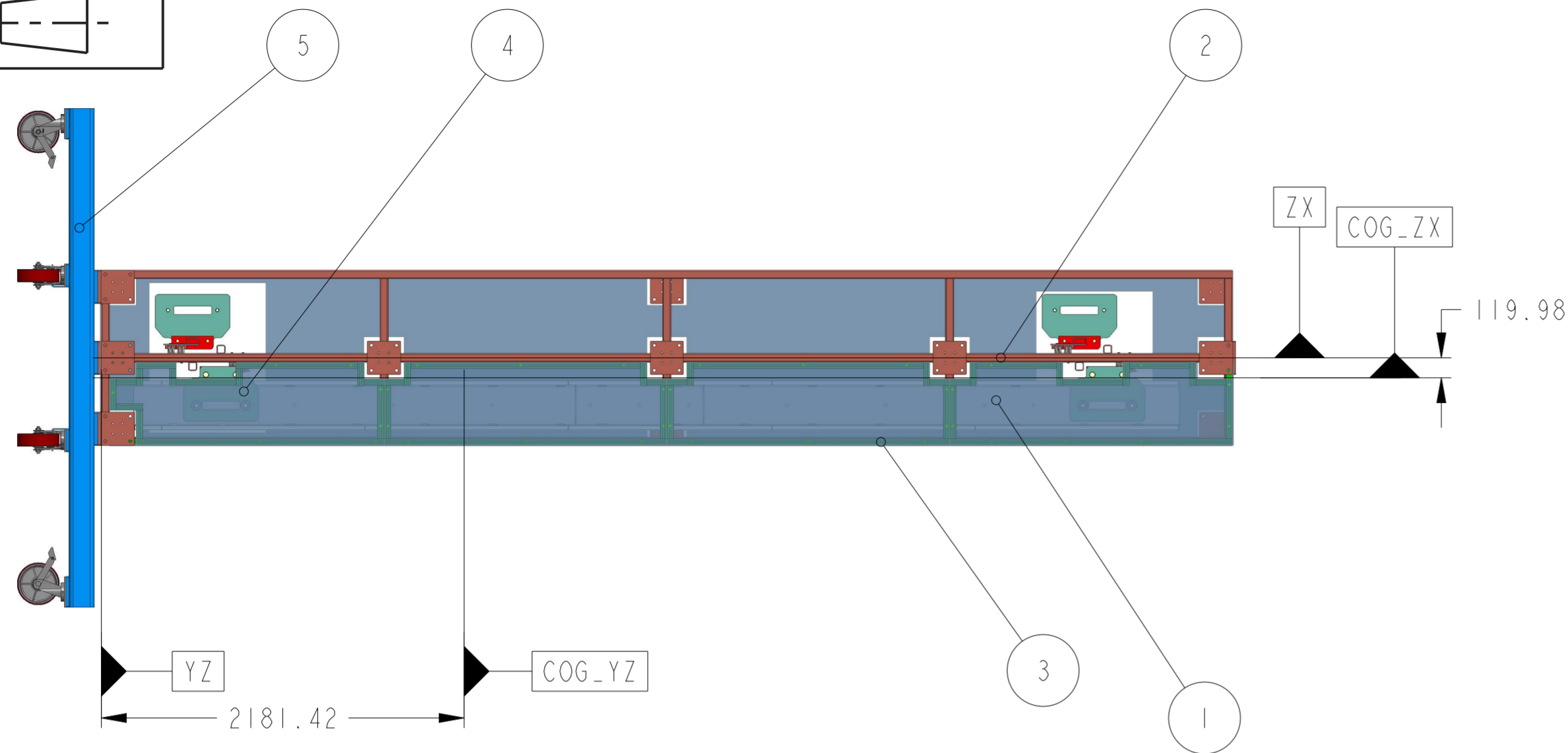

MASS CALCULATIONS

ITEM	PART/CAD No	DWG TITLE	QTY	MASS (KG)	CONTINGENCY 25% (KG)
1	NP79-01-97	BOTTOM APA	1	2277.516	2846.895
2	NP79-01-02	CENTRAL FRAME	1	UNLESS OTHERWISE SPECIFIED: ALL DIMENSIONS IN MILLIMETERS SURFACE TEXTURE VALUES IN MICROMETERS SURFACE TEXT TO BE MACHINED ALL OVER OR WHERE MARKED ✓ REMOVE BURRS AND BREAK SHARP EDGES	
3	NP79-01-07	SIDE FRAME	1		
4	NP79-01-04	TOP ATTACHMENT ASSEMBLY	2		
5	NP79-02-03	VERTICAL TROLLEY	1		
6	M16_SET		2		

TOLERANCES UNLESS OTHERWISE SPECIFIED		DRAWING PRACTICE AND TOLERANCE INTERPRATION TO BS 8888		WELDING SYMBOLS TO BS 2553	
MACHINED DIMS ±		MATERIAL		DRAWN	G. STAVRAKIS
ANGULAR ± °		TREATMENT		DATE	Jan-21-20
DO NOT SCALE		FINISH		CHECKED	
				APPROVED	

DEPARTMENT OF PHYSICS
OLIVER LODGE BUILDING

UNIVERSITY OF LIVERPOOL

PROJECT: DUNE

TITLE: ONE APA INSTALLED ONE SIDE VERT CART

DRAWING NUMBER: NP79-01-47

ARRGR. DRAWING: NP79-01

SHEET 1 OF 1

SCALE 1:30

A2

THIRD ANGLE PROJECTION

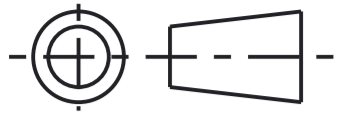

MODIFICATIONS			
ISSUE	DATE	NAME	DESCRIPTION
A	Jan-21-20	G. STAVRAKIS	FIRST ISSUE

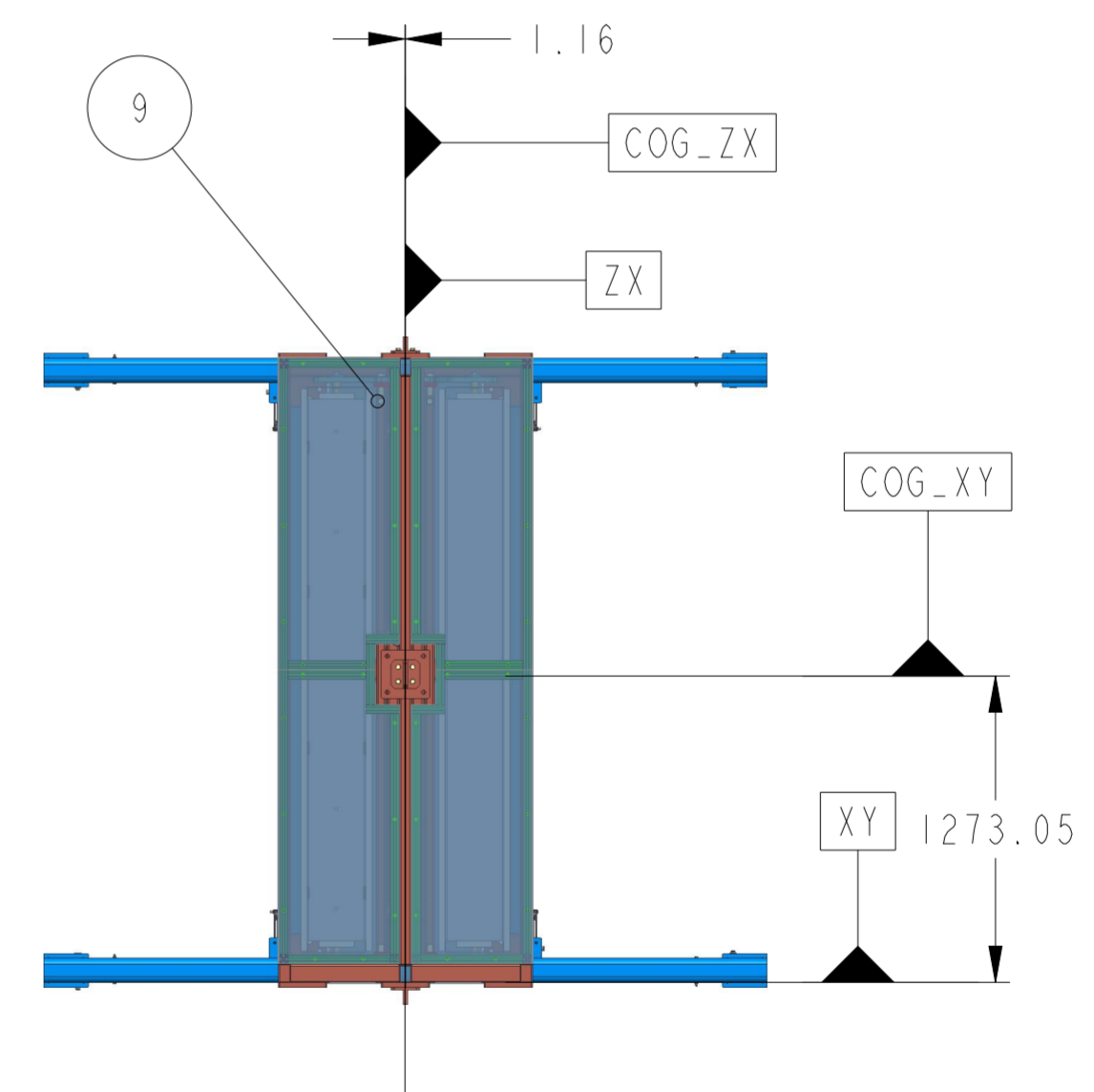
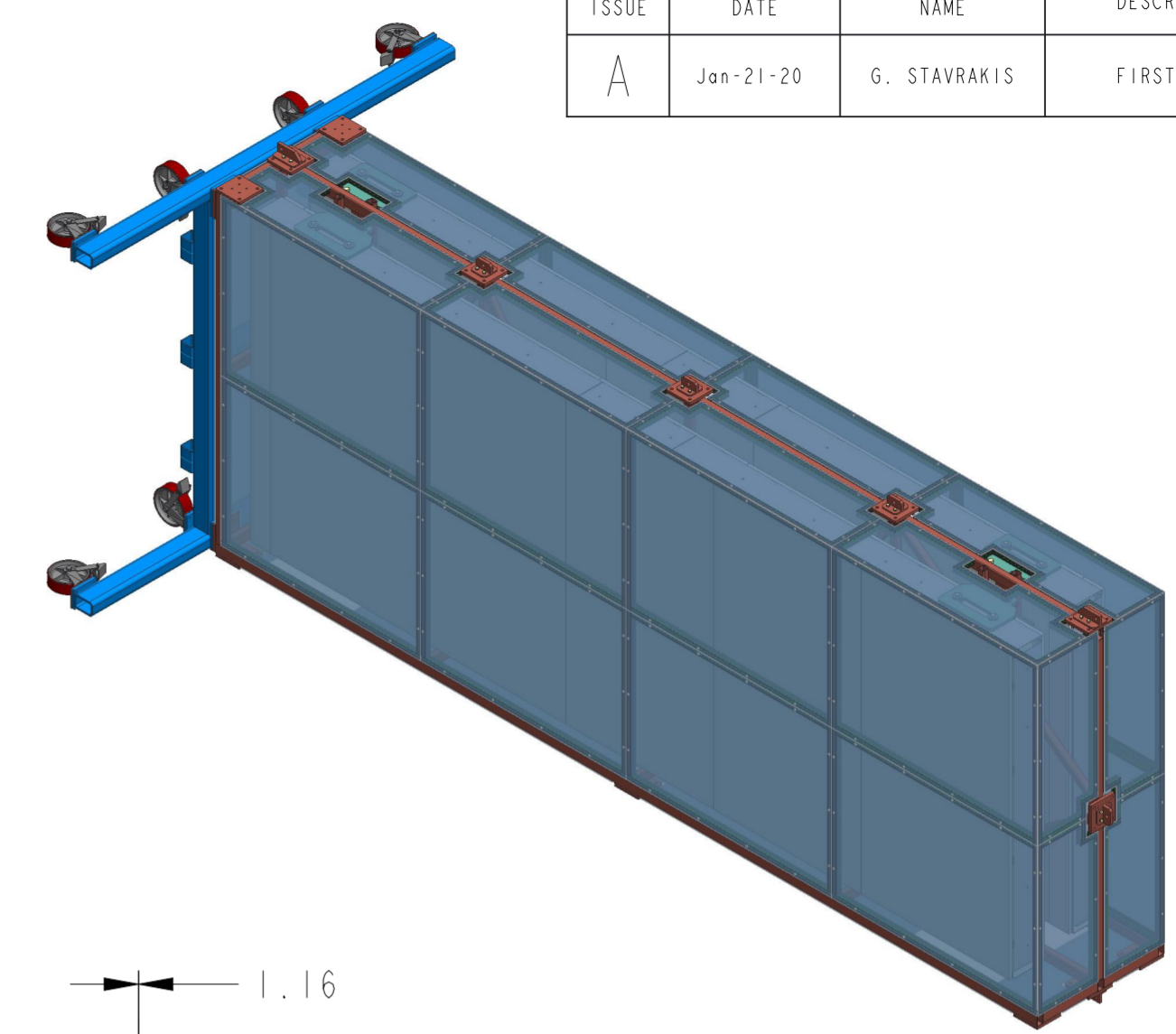
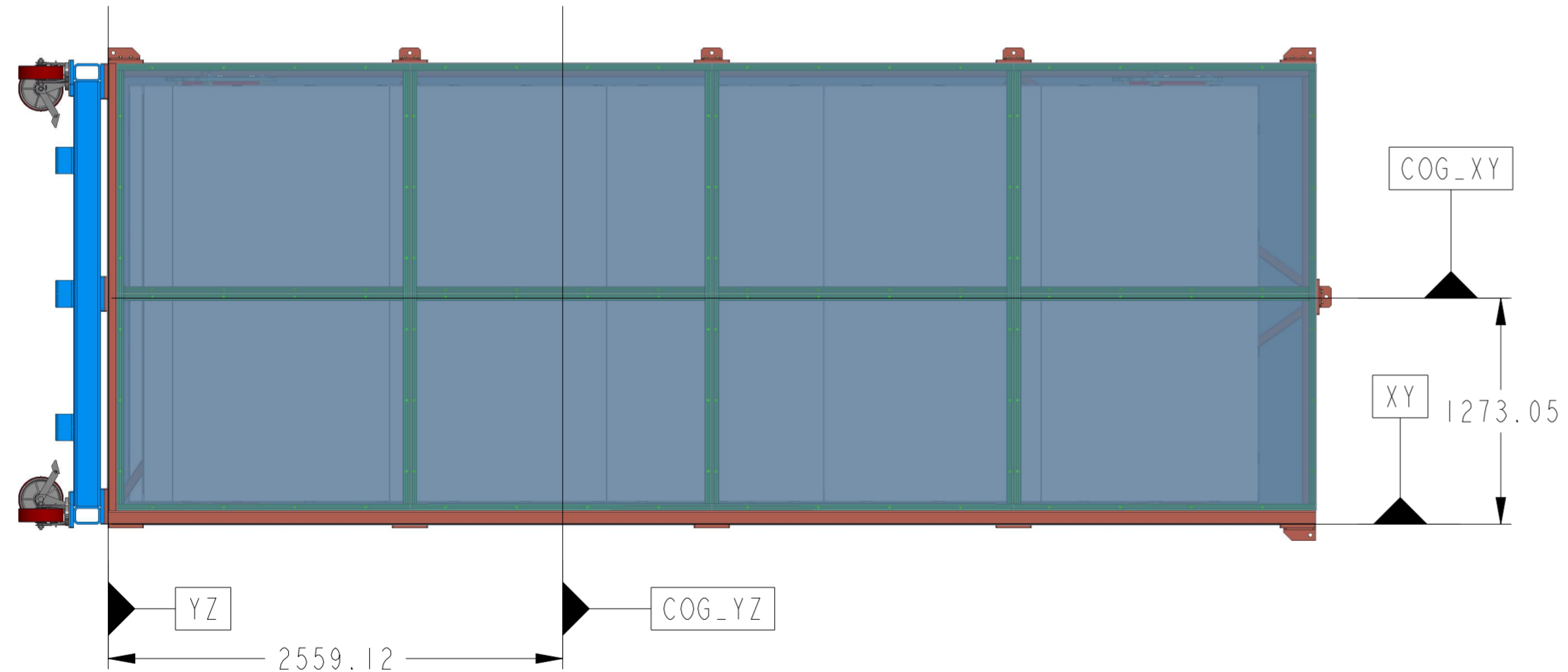
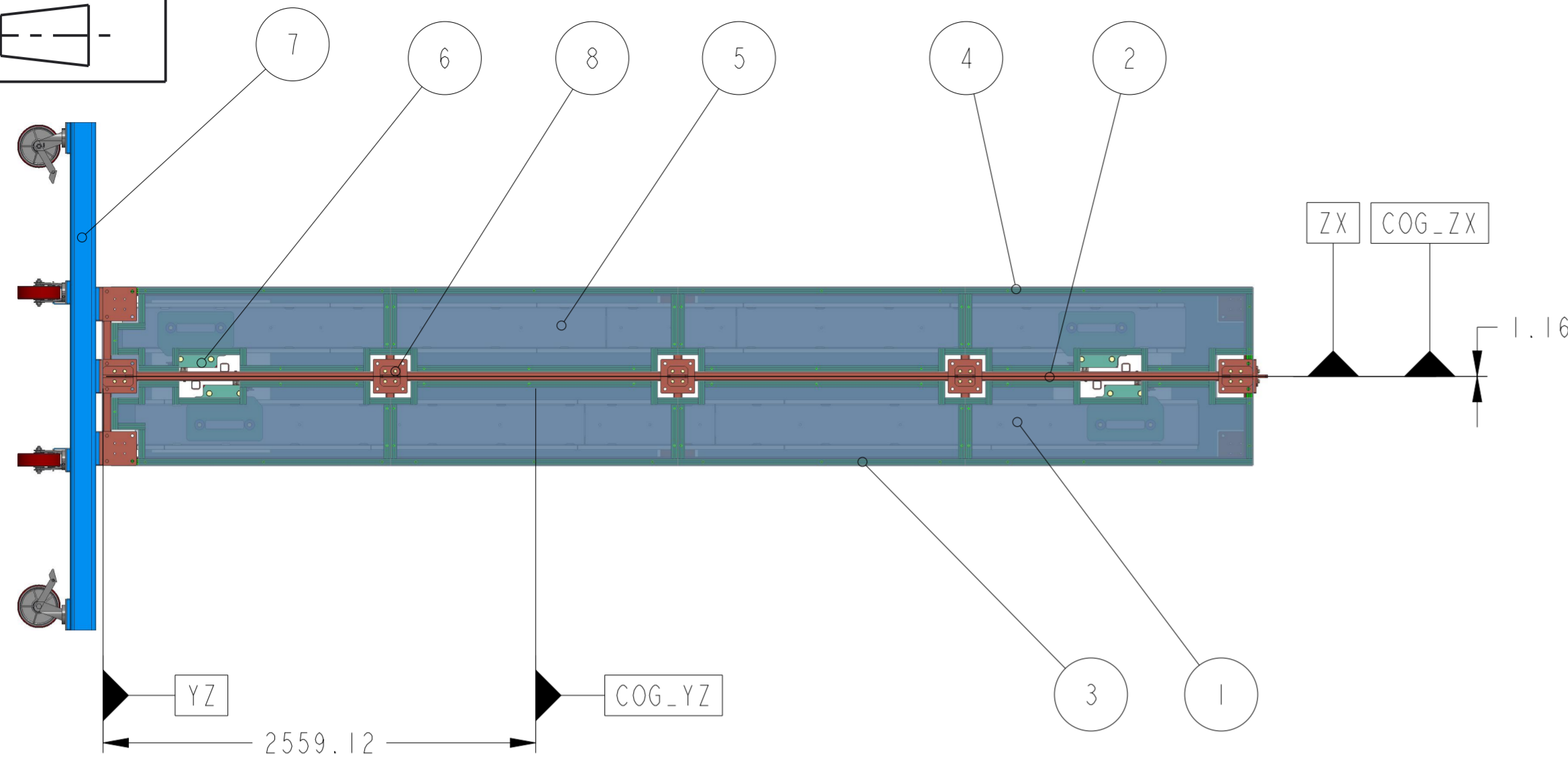

ITEM	PART/CAD No	DWG TITLE	QTY
1	NP79-01-97	BOTTOM APA	1
2	NP79-01-02	CENTRAL FRAME	1
3	NP79-01-07	SIDE FRAME	1
4	NP79-01-08	SIDE FRAME	1
5	NP79-01-98	TOP APA	1
6	NP79-01-04	TOP ATTACHMENT ASSEMBLY	4
7	NP79-02-03	VERTICAL TROLLEY	1
8	MI2_SET		24
9	MI6_SET		4

MASS CALCULATIONS	
MASS (KG)	3128.194
CONTINGENCY 25% (KG)	3910.243

UNLESS OTHERWISE SPECIFIED:
 ALL DIMENSIONS IN MILLIMETERS
 SURFACE TEXTURE VALUES IN MICROMETERS
 SURFACE TEXT TO BE MACHINE ALL OVER OR WHERE MARKED
 REMOVE BURRS AND BREAK SHARP EDGES

METRIC SCREW THREADS TO BS3643 CLASS 6H/6g	DRAWING PRACTICE AND TOLERANCE INTERPRATION TO BS 8888	WELDING SYMBOLS TO BS 2553
TOLERANCES UNLESS OTHERWISE SPECIFIED	MATERIAL	DRAWN G. STAVRAKIS
MACHINED DIMS ±	SPEC	DATE Jan-21-20
ANGULAR ± °	TREATMENT	CHECKED
DO NOT SCALE	FINISH	APPROVED

DEPARTMENT OF PHYSICS OLIVER LODGE BUILDING	UNIVERSITY OF LIVERPOOL
PROJECT DUNE	
TITLE TWO APAs INSTALLED BOTH SIDE VERT CART	
DRAWING NUMBER NP79-01-48	ARRGR. DRAWING NP79-01
SHEET 1 OF 1	SCALE 1:30
	A2