



MQXFA MAGNET INTERFACE SPECIFICATION

US-HiLumi-doc-1674
EDMS# 2031177
Date: 9/30/2019
Page 1 of 7



US HL-LHC Accelerator Upgrade Project

MQXFA MAGNET INTERFACE SPECIFICATION

Prepared by:

Giorgio Ambrosio, US HL-LHC AUP MQXFA L2 Manager, FNAL
Maria Baldini, US HL-LHC AUP MQXFA L2 Manager deputy, FNAL
Dan Cheng, US HL-LHC AUP Magnet Assembly L3 Manager deputy, LBNL
Joe Muratore, US HL-LHC AUP Magnet Vertical Test L3 Manager, BNL
Paolo Ferracin, HL-LHC WP3 Lead Engineer, CERN

Reviewed by:

Giorgio Ambrosio, US HL-LHC AUP MQXFA L2 Manager, FNAL
Sandor Feher, US HL-LHC AUP Cryo-assembly L2 Manager, FNAL
Tom Page, US HL-LHC AUP System Integration Manager, FNAL
Ezio Todesco, HL-LHC WP3 Leader, CERN

Approved by:

Soren Prestemon, US HL-LHC AUP Magnet Assembly L3 Manager, LBNL
Giorgio Ambrosio, US HL-LHC AUP MQXFA L2 Manager, FNAL
Sandor Feher, US HL-LHC AUP Cryo-assembly L2 Manager, FNAL
Tom Page, US HL-LHC AUP System Integration Manager, FNAL
Ruben Carcagno, US HL-LHC AUP Deputy Project Manager, FNAL
Giorgio Apollinari, US HL-LHC AUP Project Manager, FNAL



MQXFA MAGNET INTERFACE SPECIFICATION

US-HiLumi-doc-1674
EDMS# 2031177
Date: 9/30/2019
Page 2 of 7

Revision History

Revision	Date	Section No.	Revision Description
V0	10/2/18	All	Initial Release
V0.1	11/26/18	All	Updated magnet bore, wire length and references
V0.2	1/18/19	2.3	Current lead lengths, wires not twisted
V0.3	4/8/19	2.3	Asymmetric current leads, added sentence about splice order
V0.4	5/1/19	2.3	Added CLIQ cable info to Table 1, updated reference [6]
V0.5	5/7/19	2.3	Changed length of instrumentation wires to 4.5 m.
V1	5/31/19	2.3	Changed length of power lead A from 0.5 m to 445 mm, and of power lead B from 2.1 m to 2040 mm.
V1a	8/13/19	Header	Added EDMS#
V9	9/30/19	2.3	Changed Figure 2: CLIQ leads and their exits



MQXFA MAGNET INTERFACE SPECIFICATION

US-HiLumi-doc-1674
EDMS# 2031177
Date: 9/30/2019
Page 3 of 7

TABLE OF CONTENTS

1. INTRODUCTION	4
2. MQXFA INTERFACES	4
2.1. MECHANICAL INTERFACES	4
2.2. COLD MASS WELDING	5
2.3. ELECTRICAL INTERFACES	5
3. REFERENCES	7

1. Introduction

MQXFA magnets [1,2] are the quadrupole magnetic components of the HL-LHC Q1 and Q3 inner triplet optical elements in front of the interaction points 1 (ATLAS) and 5 (CMS). Two MQXFA magnets are installed in each Q1 or Q3. Since these magnets are identical whether installed in Q1 or Q3, the interface specifications are identical for all MQXFA magnets.

This specification defines the mechanical and electrical interfaces of the MQXFA magnets, which are relevant for the incorporation of these elements into the LMQXFA cold mass assembly, and subsequently into the cryostat which completes the LQXFA/B cryo-assembly.

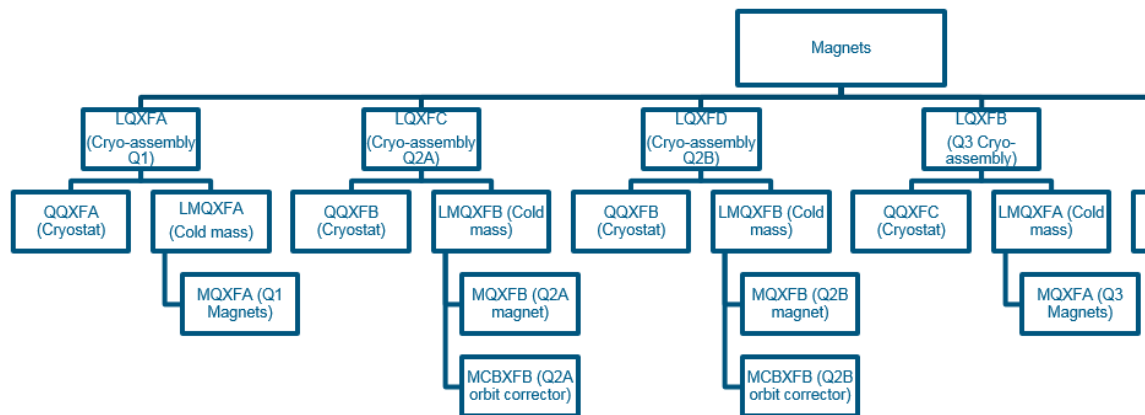

Figure 1: CERN Naming Conventions for HL-LHC Inner Triplets

2. MQXFA interfaces

2.1. Mechanical interfaces

The MQXFA Magnet mechanical interfaces are defined in [3]. This drawing defines:

- The diameter, length and weight of the magnet.
- The longitudinal position of the magnetic center relative to the return end of the yoke.
- The position and aperture of the holes for heat exchangers.
- The position of the slots for tack blocks.
- The features of the slots where the tack blocks will be inserted.
- The positions and features of the alignment slots.
- The envelope of the lead connection block (“pizza box”).
- The orientation of the leads when magnet is in horizontal position.

The bore of the MQXFA magnet has a 146.7 mm inside diameter at room temperature after insertion of coil-bumpers and magnet pre-load, allowing for the insertion of an insulated beam tube.

The OD of the beam tube is 144.7 +0.7/-0.0 mm at room temperature. The beam tube insulation thickness is 0.2 mm.



MQXFA MAGNET INTERFACE SPECIFICATION

US-HiLumi-doc-1674

EDMS# 2031177

Date: 9/30/2019

Page 5 of 7

The iron yoke of the MQXFA magnet has four cooling channels. The two upper channels (wrt. to the orientation shown in Fig 2) will be used for the heat exchangers of the LMQXFA cold mass. The minimum diameter of the MQXFA yoke cooling channels is 77 mm at room temperature.

2.2. Cold Mass Welding

When the two half shells of the LMQXFA cold mass are welded together the weld shrinkage may increase the coil pre-load. This pre-load increase may cause excessive conductor strain if the interference between magnet and cold mass is not limited. Therefore, this interference shall be kept under control and the coil pre-load increase shall not exceed 15 MPa at room temperature.

2.3. Electrical Interfaces

The MQXFA magnet has two 18 kA leads extending from the lead end of the assembly. Each lead is made of two NbTi cables [2]. The leads will be labelled A and B according with the CERN standard [4]. Looking from the lead end, the "A" lead is the lower exiting lead and the "B" lead is the upper exiting lead with the magnet oriented as shown in Figure 2. The splice order (e1i – i4e – i2e – e3i) gives a positive gradient as defined by CERN document "LHC Magnet Polarities" [4] if the current enters lead "A".

The minimum length of Current Lead "B" is 2040 mm from the splice-connection block ("pizza box"). The minimum length of Current Lead "A" is 445 mm long from the splice-connection block ("pizza box").

The MQXFA magnet has two CLIQ leads [5] extending from the lead end of the assembly. The leads will be labelled "A" and "B", based on how close they are in the electrical circuit to the A/B current leads. Looking from the lead end, with the magnet oriented as shown in Figure 2, the CLIQ "A" lead is one the left, and the CLIQ "B" lead is on the top. The CLIQ leads exiting the splice-connection block ("pizza box") are 2 m long, such that further routing and splicing can be completed.

CLIQ "A": 1-4 splice; CLIQ "B": 2-3 splice

Quadrant Splice Order: "A" e1i - i4e - i2e - e3i "B"

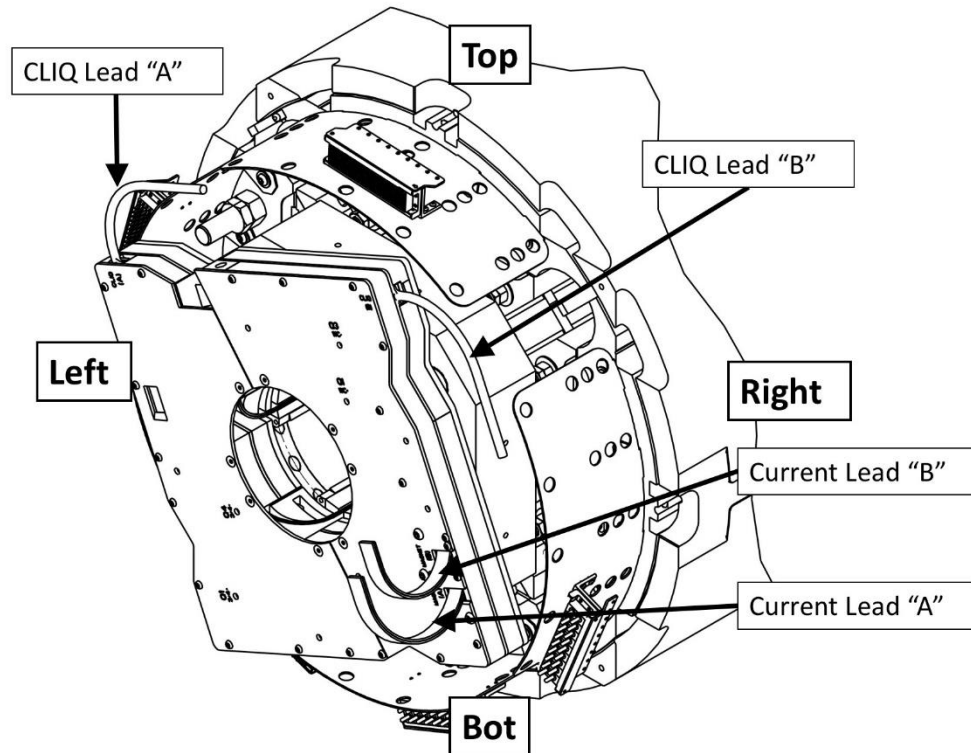

Figure 2: Power leads and CLIQ leads on a completed MQXFA magnet.

The instrumentation wires required for the MQXFA magnet are listed in Table 1. All wires shall not be twisted because they must go through a capillary tube in the cold mass. Each wire will be labelled indicating functionality and location according to [6]. All voltage tap and quench heater wires exit from the lead end of the magnet.

The MQXFA magnet has 2 voltage taps for each internal Nb₃Sn-NbTi splice resulting in 16 wires. The voltage tap wires are AWG 26 gauge in accordance with [6], and each wire is 4.5 m long from the connection box ("pizza box").

The MQXFA magnet has three quench detection voltage taps located on each magnet lead and at the electrical midpoint of the magnet circuit. According to MQXFA Magnets Functional Requirements Specification [1] each voltage tap used for quench detection must have a redundant voltage tap. Redundancy of the voltage taps located on magnet leads is provided by the voltage taps on internal Nb₃Sn-NbTi splices to magnet leads. Therefore, the total number of wires for quench protection is 4. The quench protection wires are AWG 26 gauge and are 4.5 m long from the connection box ("pizza box").

The MQXFA magnet has four outer layer heater strips per coil (one high-field and one low-field strip on each coil side). Pairs of heater strips are connected in series according to [6]. The heater-heater connections are done at magnet return end. Therefore, there is a total of 16 heater wires exiting from the lead end. The heater wires are AWG 18 gauge and are 4.5 m long from the connection box ("pizza box").



MQXFA MAGNET INTERFACE SPECIFICATION

US-HiLumi-doc-1674
EDMS# 2031177
Date: 9/30/2019
Page 7 of 7

MQXFA heaters and CLIQ leads are compatible with the HL-LHC Inner Triplet quench protection system [7].

Table I. Instrumentation wires, heater wires and CLIQ cables. Length is measured from the magnet splice-connection box (“pizza box”).

Wire	Number	Gauge/OD	Length	Description	Twisted/Not
Quench detection	4	26 AWG	4.5 m	AXON HH2619 - LH [8]	Not twisted
Voltage tap	16	26 AWG	4.5 m	AXON HH2619 - LH [8]	Not twisted
Heater wire	16	18 AWG	4.5 m	AXON HH1819 - LH [9]	Not twisted
CLIQ cable	2	8.6 mm OD	2 m	Habia Cable 700061251 [5]	Not twisted

3. References

1. MQXFA Magnets Functional Requirements Specification, EDMS#1535430; US-HiLumi-doc-36
2. MQXFA Final Design Report, US-HiLumi-doc-948
3. MQXFA Structure & Mechanical Interface Specification Drawing US-HiLumi-doc-1885
4. LHC MAGNET POLARITIES, CERN Specification LHC-DC-ES-0001 rev 3.2, 2005-08-09, EDMS# 90041
5. CLIQ leads drawing, US-HiLumi-doc-998; EDMS#2214983
6. HL-LHC Triplet Electrical Scheme, US-HiLumi-doc-1097; EDMS#2002347
7. HL-LHC Decision management: WP3 - Q1/Q2/Q3 protection baseline, EDMS# 1972818
8. Drawing: S515769BB-ENG_DWG; US-HiLumi-doc-1603, FC0067203
9. Drawing: S563483AA_DWG; US-HiLumi-doc-1603, FC0067205