

# Operational Experience of a Cryomodule Test Stand for LCLS-II (& HE) Cryomodules

---



Brian Hartsell, Fermilab – [hartsell@fnal.gov](mailto:hartsell@fnal.gov)

16 APR 2024

FERMILAB-SLIDES-24-0089-AD

This manuscript has been authored by Fermi Research Alliance, LLC under Contract No. DE-AC02-07CH11359 with the U.S. Department of Energy, Office of Science, Office of High Energy Physics.

# About Me

---

- ~20 years of experience, 10 'in industry' in a range of mechanical engineering roles and nearly 12 at Fermilab
- Lead installation/removal activities and vacuum systems at CMTS since the first test in 2016
- Project engineer for LCLS-II-HE at Fermilab

# CMTS1 Introduction

CryoModule Test Stand 1 was built specifically for the purpose of testing Tesla type cryomodules at Fermilab, including cryomodules for LCLS-II and LCLS-II-HE.

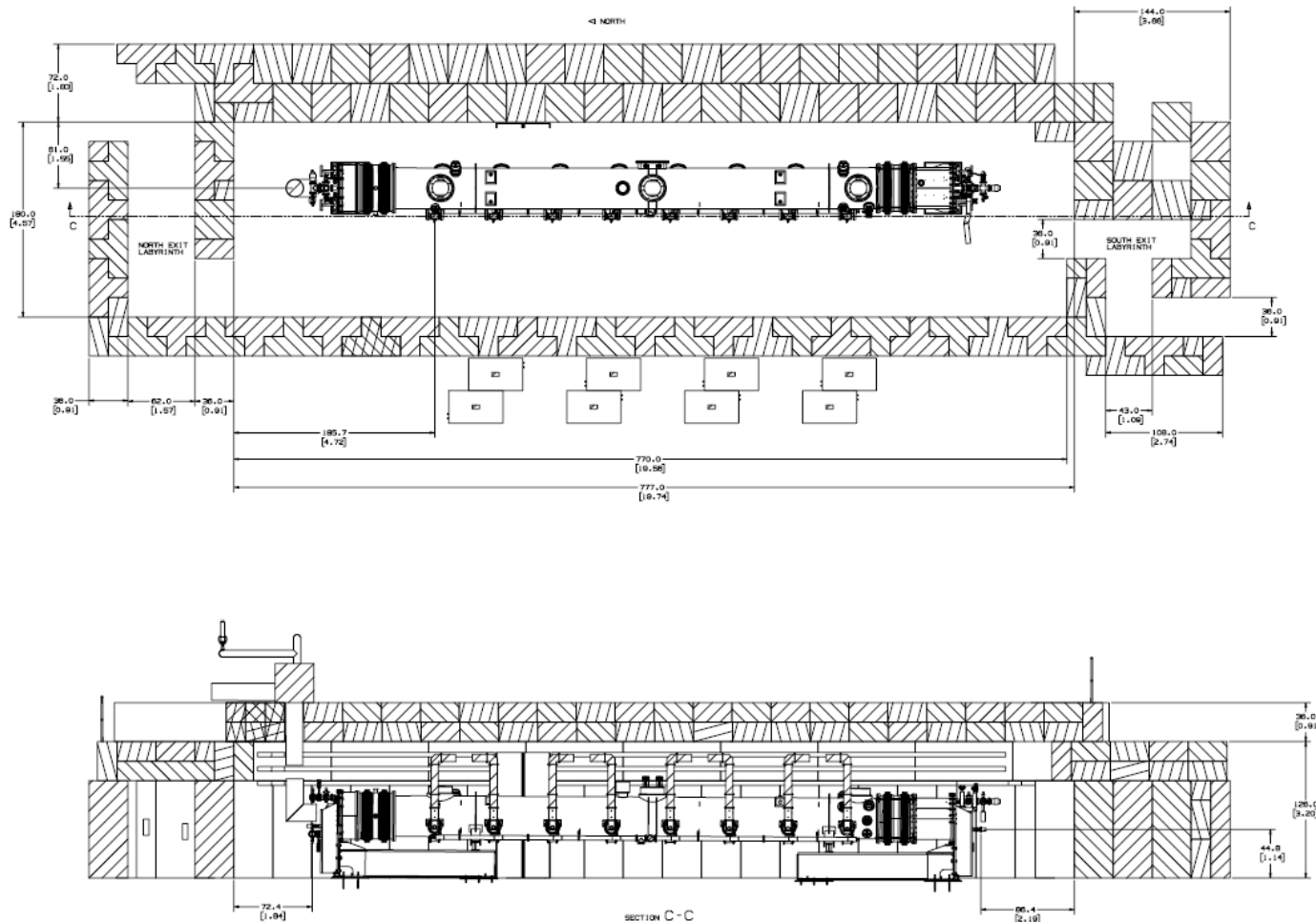

# CMTS1 Current Status

We have completed over 35 cryomodule tests of varying style cryomodules (1.3 LCLS-II and LCLS-II-HE and 3.9 GHz LCLS-II) over 8 years.





# LCLS-II and HE cryomodule vacuum systems

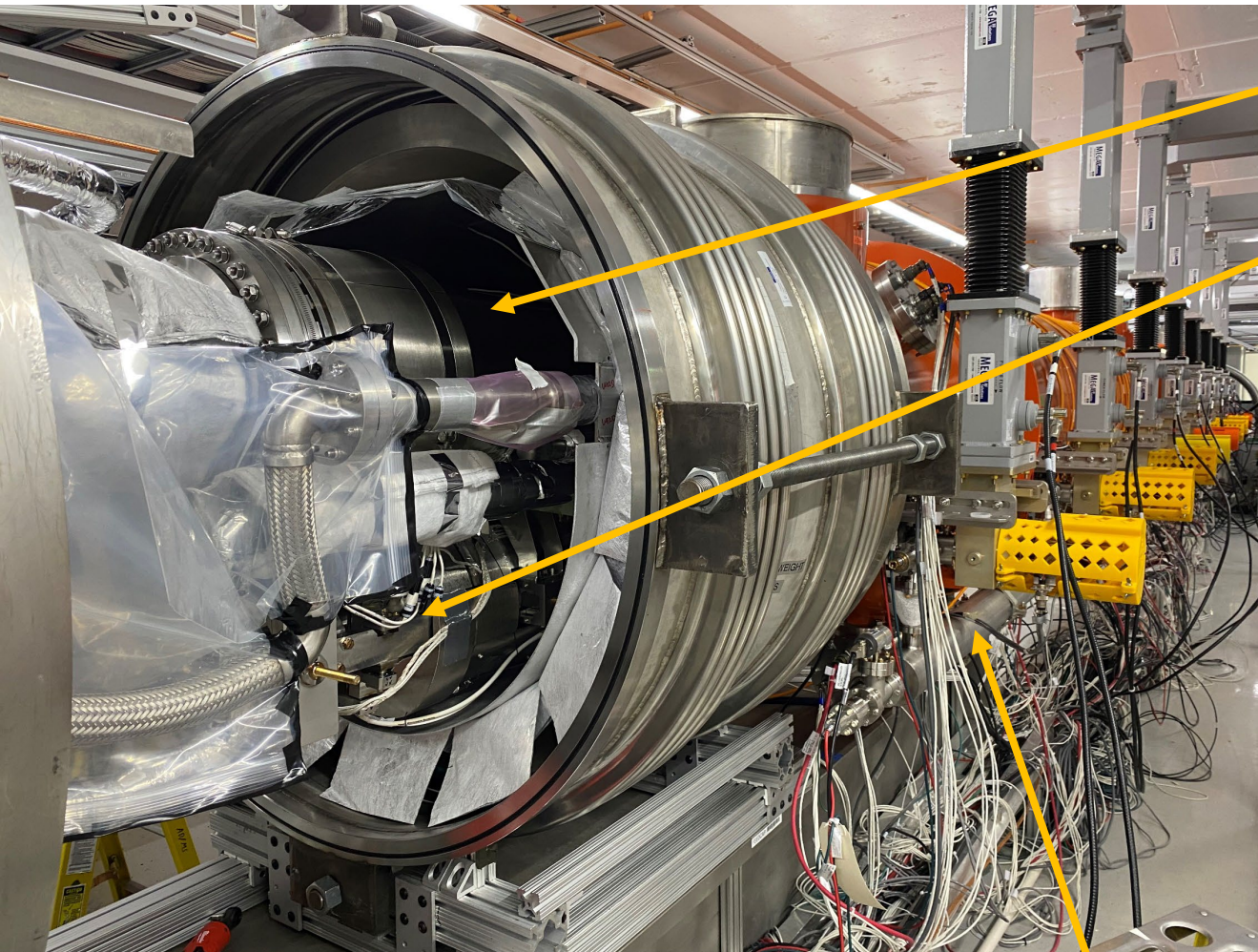

Insulating

Beamline

Coupler

This connection not typically made and replaced with a window

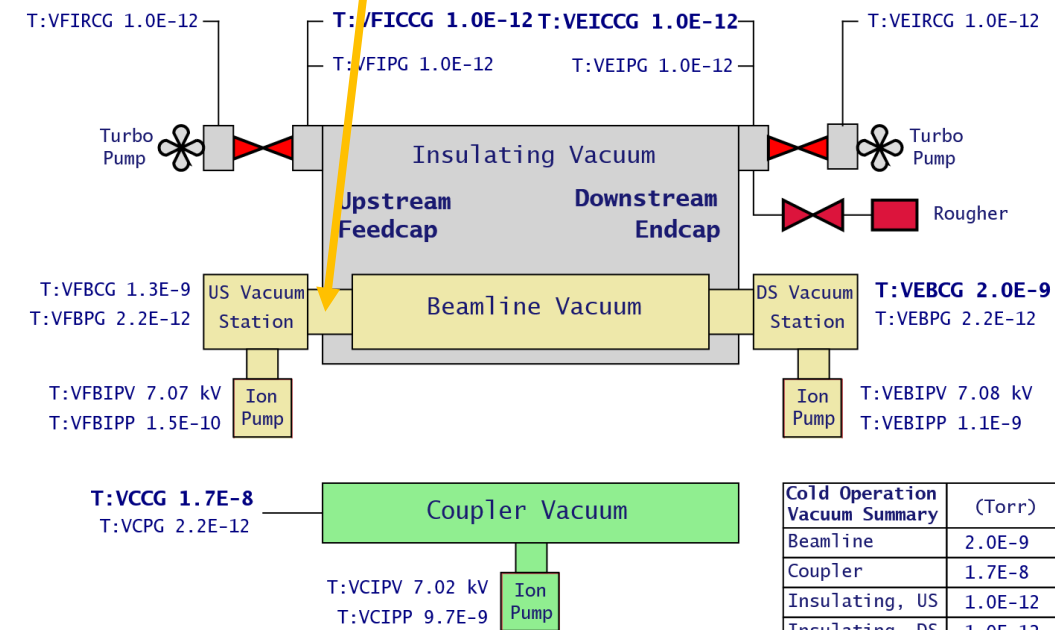

data acquisition:09:56:49

Cold Operation Vacuum Summary	(Torr)
Beamline	2.0E-9
Coupler	1.7E-8
Insulating, US	1.0E-12
Insulating, DS	1.0E-12

# Vacuum system acceptance criteria

---

Various vacuum systems have different acceptance criteria both warm and cold.

Cryomodule beamline vacuum prior to cooldown	$1 \times 10^{-8}$	Torr
Cryomodule insulating vacuum prior to cooldown	$1 \times 10^{-4}$	Torr
Cryomodule warm coupler vacuum prior to cooldown	$1 \times 10^{-7}$	Torr
Cryomodule beamline vacuum at 2 K	$1 \times 10^{-9}$	Torr
Cryomodule insulating vacuum at 2 K	$1 \times 10^{-6}$	Torr
Cryomodule warm coupler vacuum at 2 K	$5 \times 10^{-8}$	Torr

# Insulating vacuum

Prevents heat transfer through convection and allows MLI to serve its function to prevent radiative heat transfer. Vacuum space needs to be  $<1\text{E-}4$  torr for MLI. Typical values at CMTS are  $5\text{E-}8$  to  $1\text{E-}7$  torr when cold and  $5\text{E-}5$  torr warm.

Rough pumping:  $600\text{ m}^3/\text{s}$

Pumping: Two  $\sim 150\text{ L/s}$  turbopumps, one at each end

Typical leak check sensitivity:  $\sim 1\text{E-}7$  torr-liter/sec

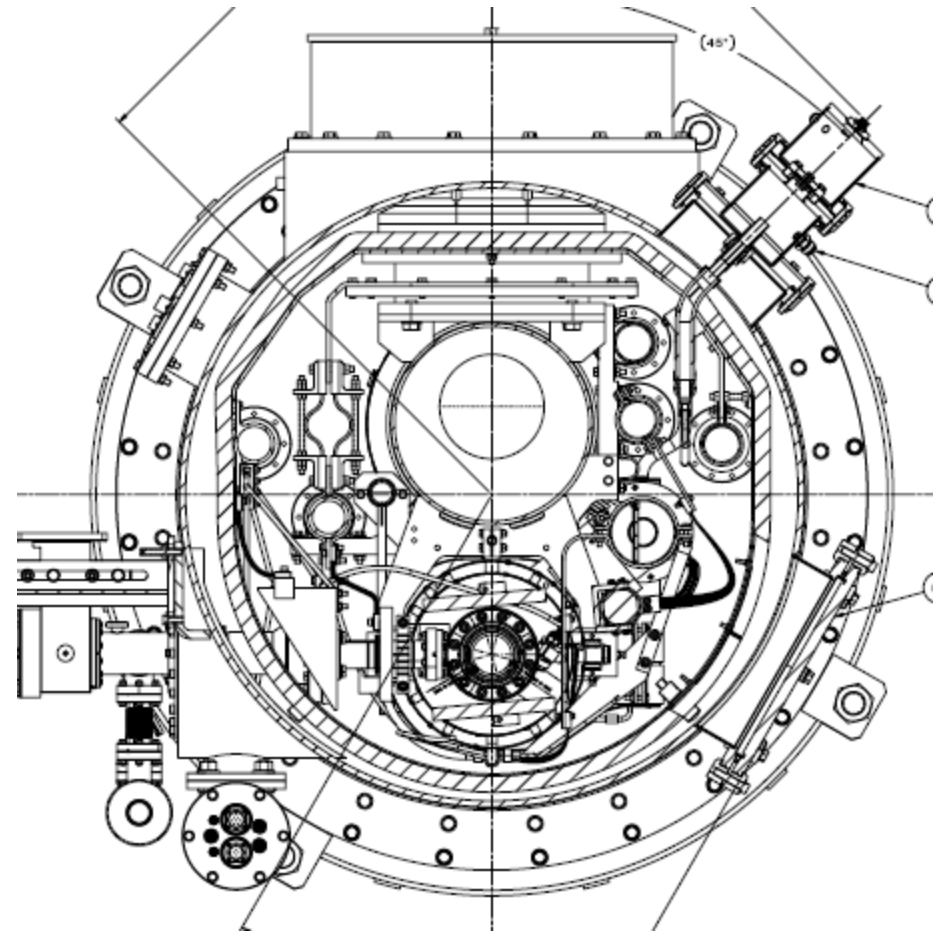



# Insulating vacuum pumping stations

Nearly identical pumping stations at each end of the CM.

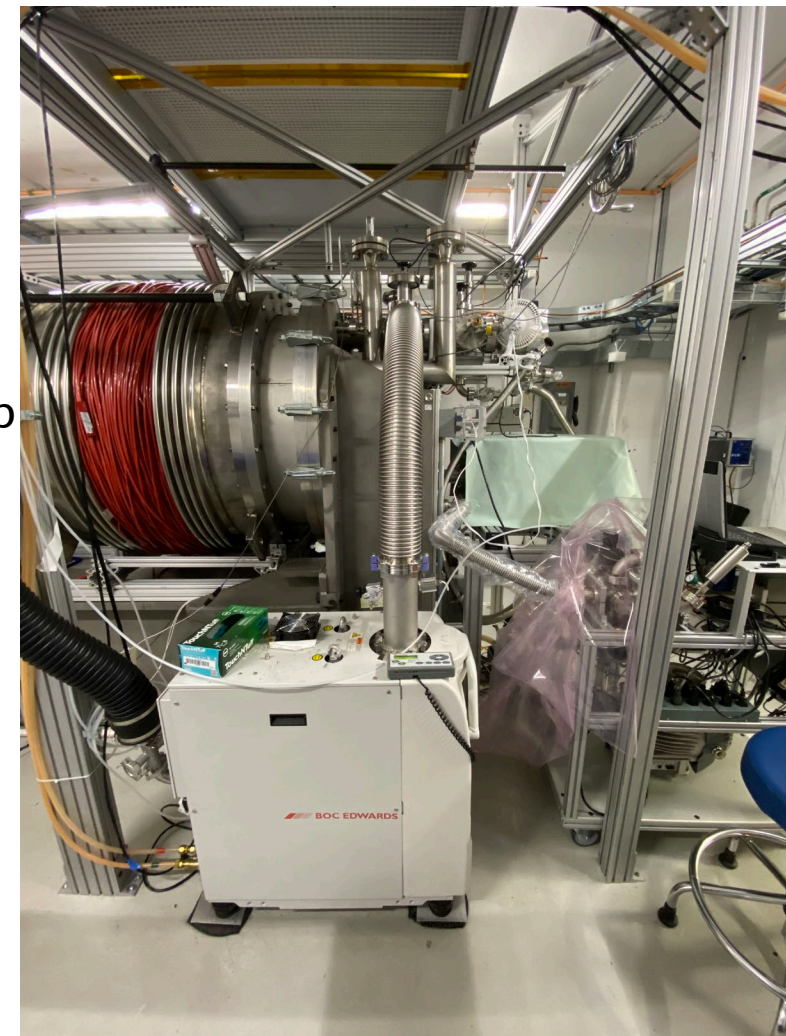
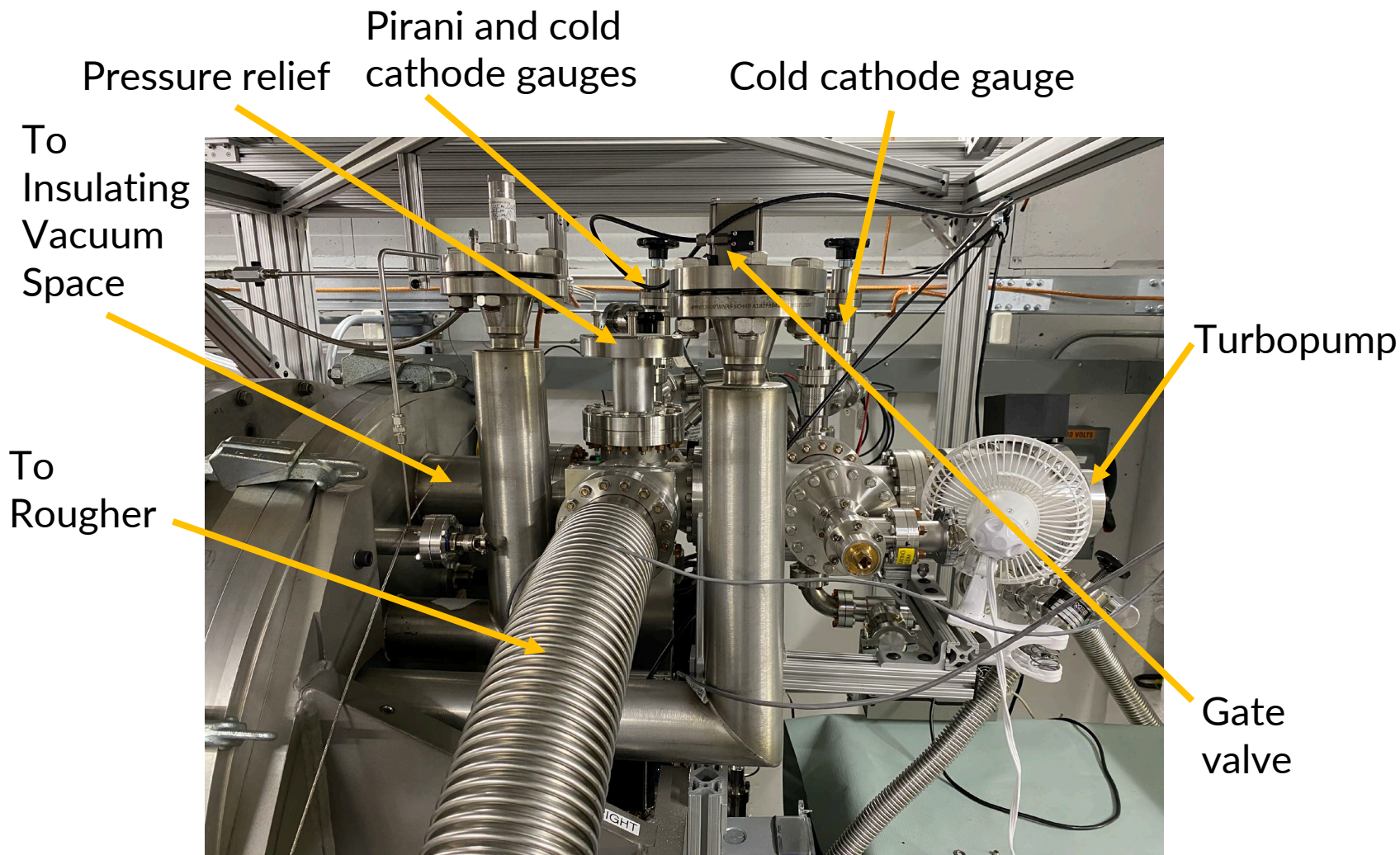



# Beamline vacuum

8 cavities, a BPM, and two gate valves are assembled in a cleanroom to minimize particulate contamination. Typical vacuum levels are  $\sim 5E-10$  torr when cold at the vacuum station, lower in the cryomodule and  $3E-9$  torr warm.

Pumping: Fermilab built mass flow control pumping carts

Two 150 L/s ion pumps, one at each end. Typically 1 connected to CM.

Typical leak check sensitivity:  $\sim 1E-11$  torr-liter/sec

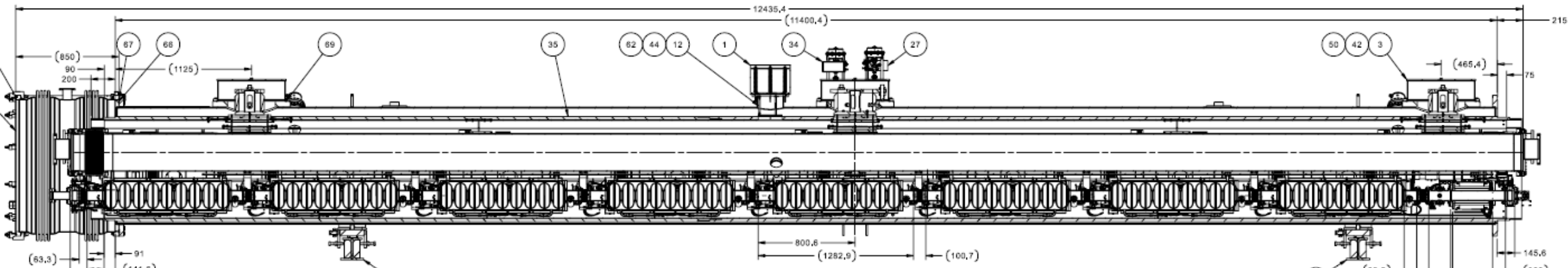

# Beamline vacuum pumping stations

Mass flow cart (MFC) setup

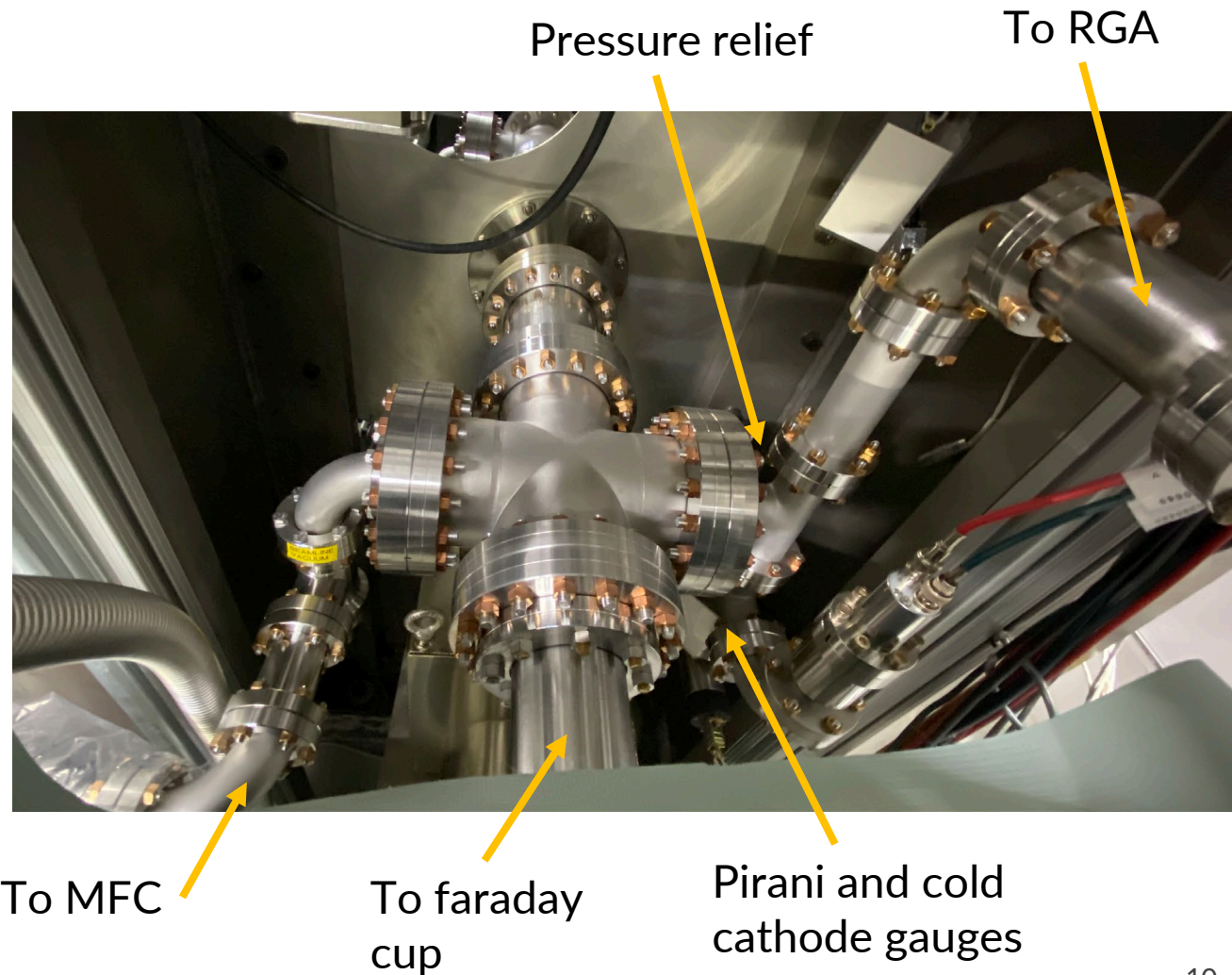
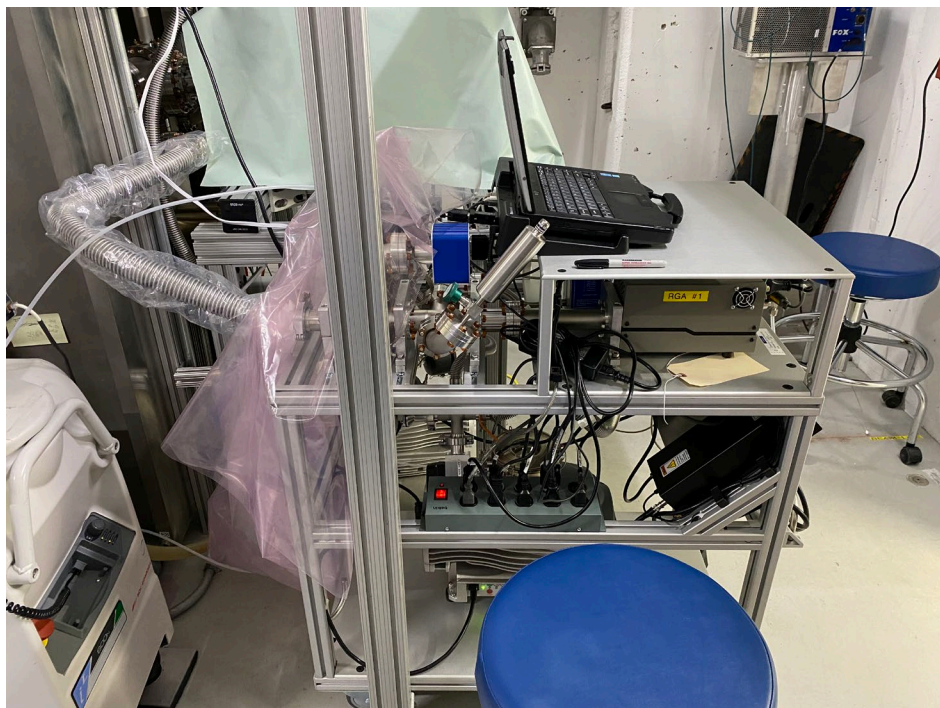



# Coupler vacuum

A UHV 'coupler pumping line' runs the length of the cryomodule and provides electrical isolation for the coupler system providing power to the cavities. Pressure typically  $\sim 5\text{E-}8$  torr warm,  $\sim 5\text{E-}9$  torr cold.

Pumping: Initial pumpdown with a turbo cart

75 L/s ion pump with TSP (not activated at CMTS) installed on CM

Typical leak check sensitivity:  $\sim 1\text{E-}11$  torr-liter/sec

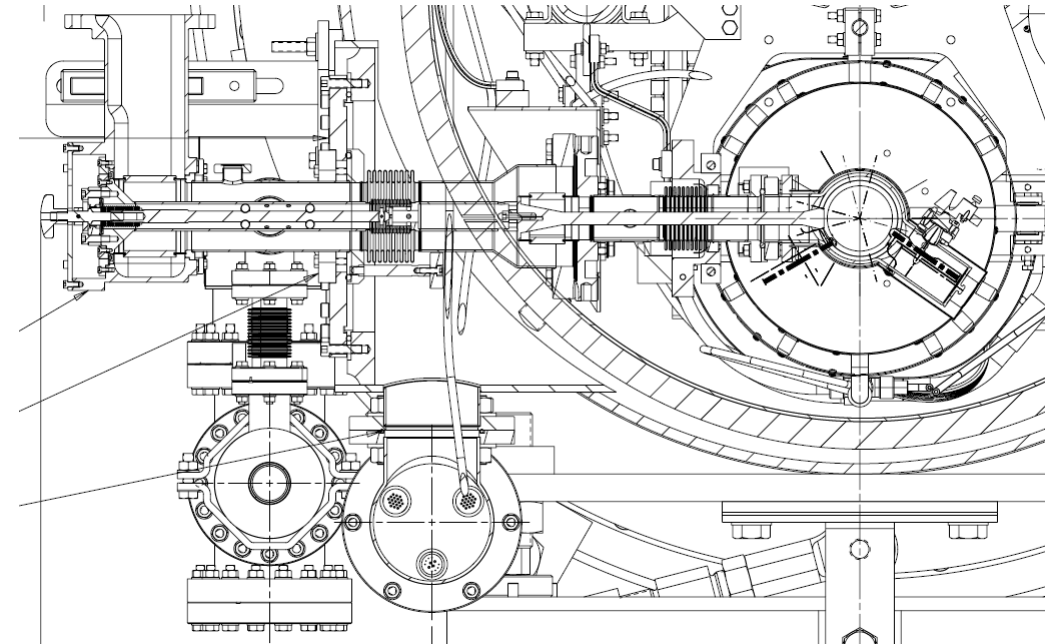



# Vacuum installation procedure

- Temporary cleanroom set up and downstream beamline vacuum connected to the pumping station. Leak check connection and RGA scan, open gate valve to CM to pump down.
- Cryogenic interconnect work
- Coupler vacuum pumped down via turbo cart and ion pump turned on.
- Close insulating vacuum bellows and establish vacuum.
  - During pump and backfill cycle, backfill with 5 torr helium to leak check beamline vacuum.
- Outside air leak checks to insulating vacuum, cryo interconnect leak checks

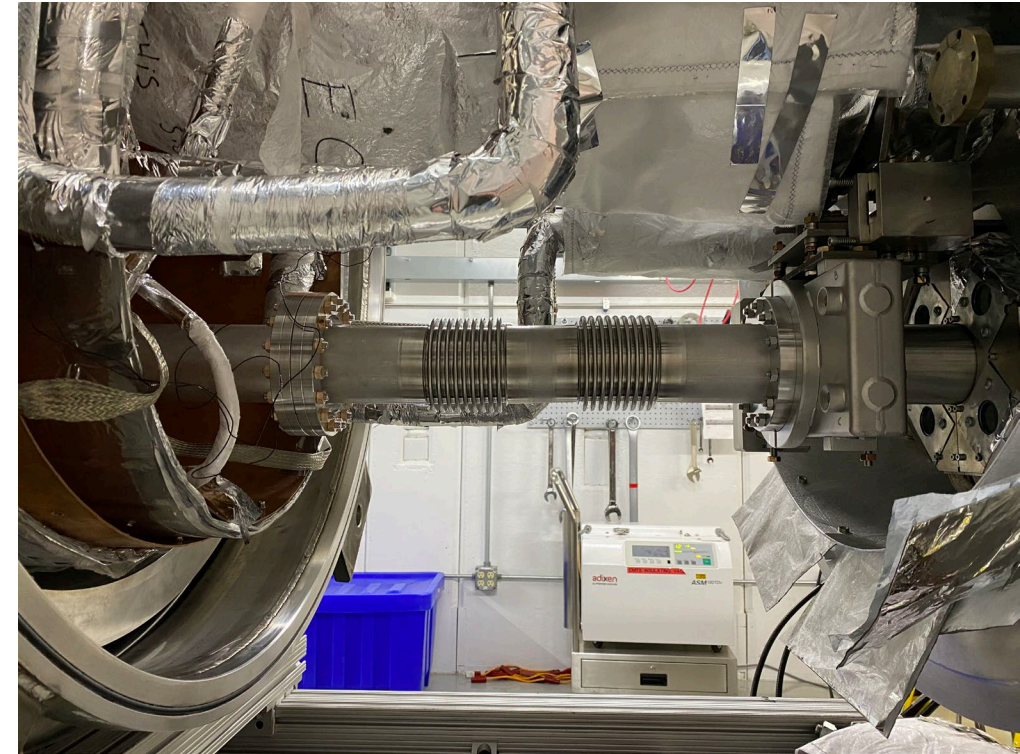

# Lessons learned – Insulating vacuum is **dirty**

Blue is warm and gate valve open to CM, Orange is a base scan of the chamber with the RGA (gate valve closed), grey is with CM cold (cryo pumping). No updated RGAs available after Loctite was implemented on many fasteners.

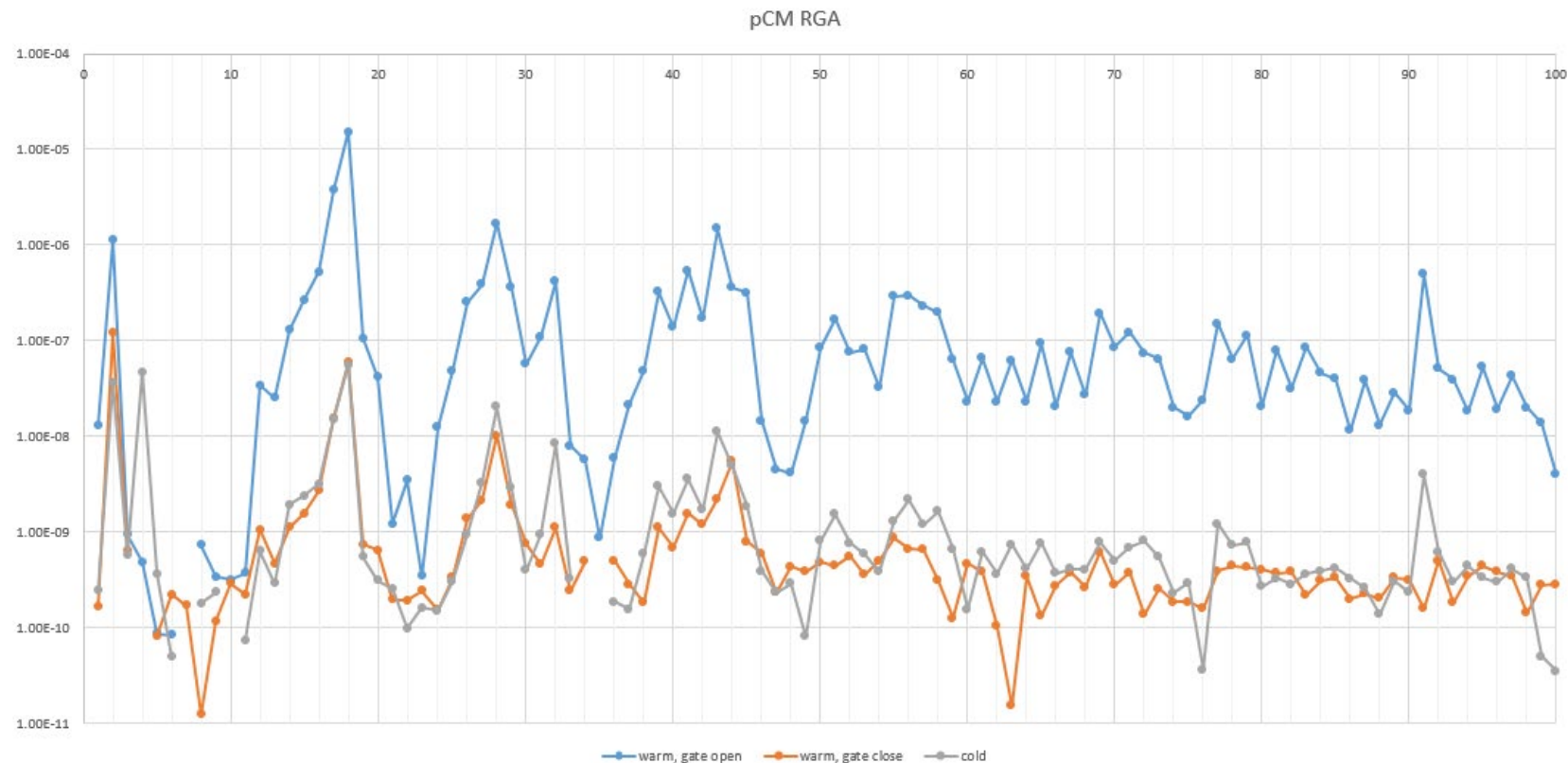

# Lessons learned – Insulating vacuum is **dirty**

Cold cathode gauges are lasting about two cryomodule tests on average (~two months of operation).

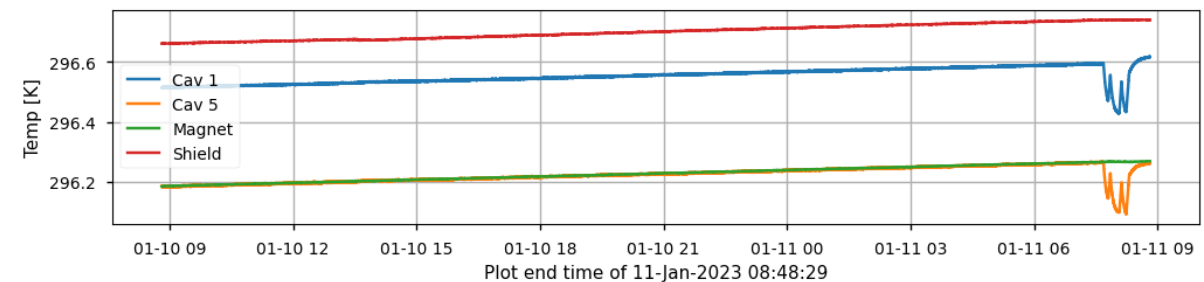
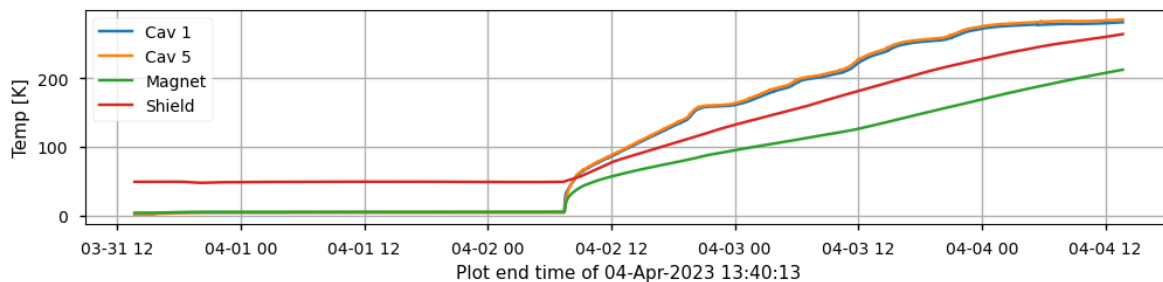
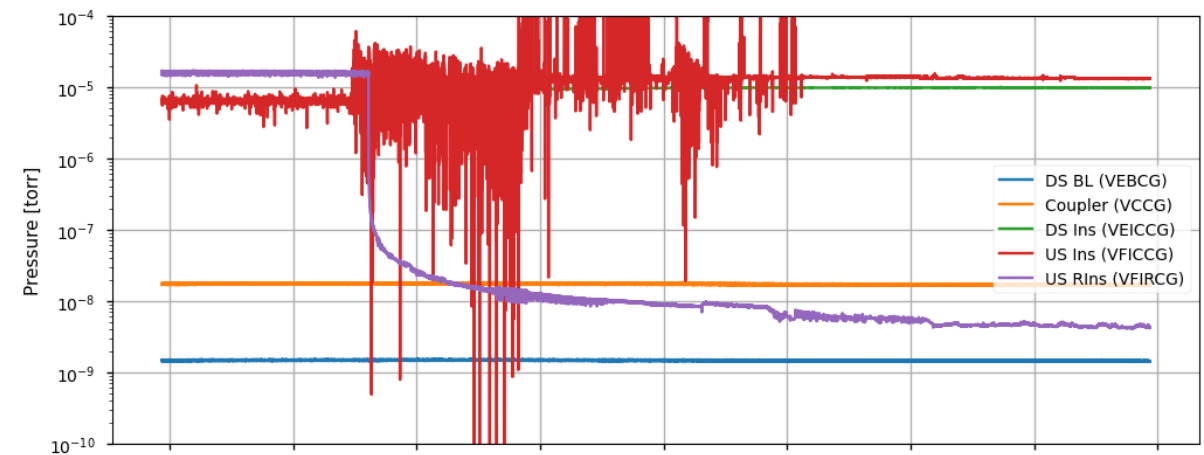
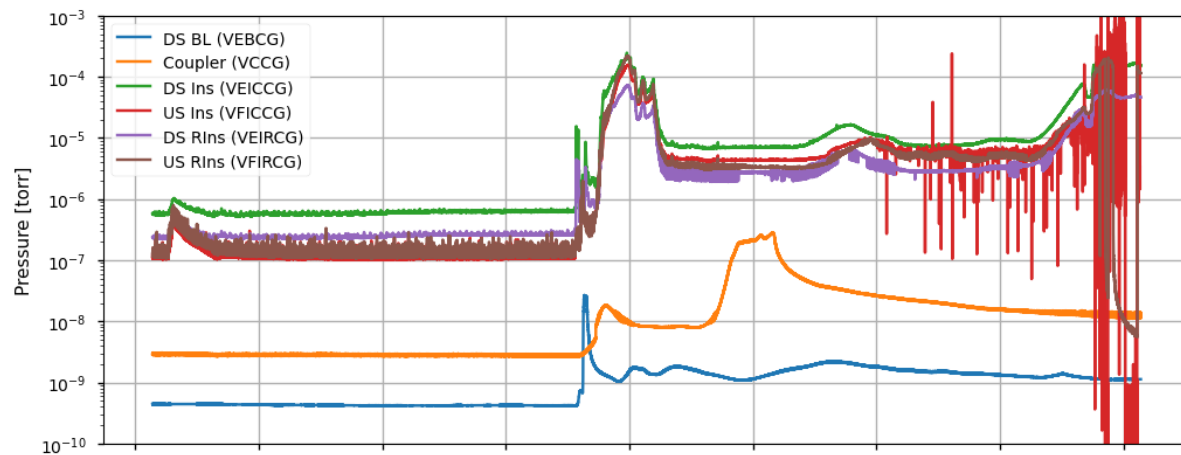



# Lessons learned – Insulating vacuum is dirty

Modified connection points to use two right angle valves to allow for easy swap and leak check during cold testing.

Typical contamination is shown below left.

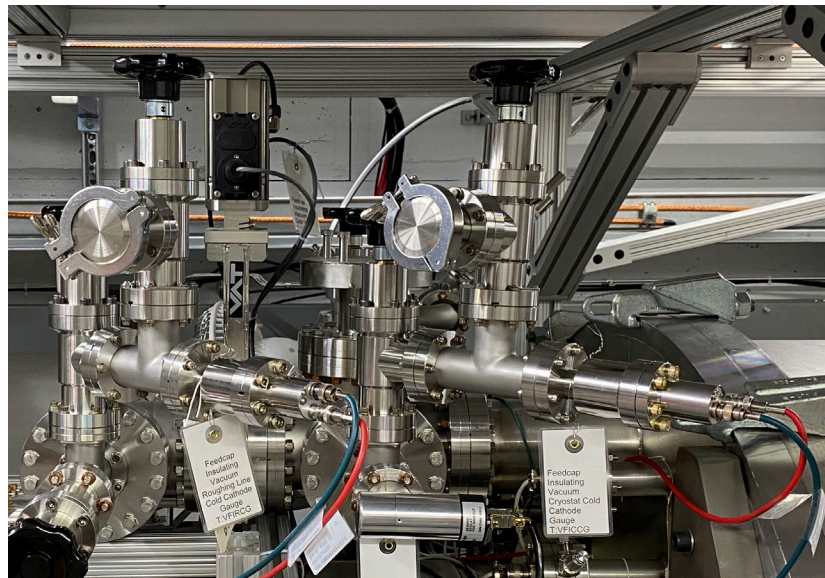
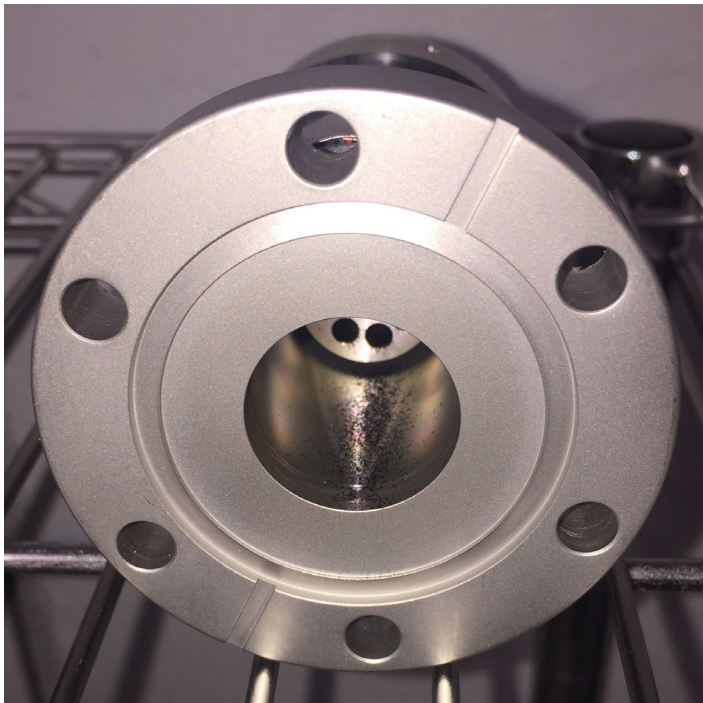

# Lessons learned – Insulating vacuum is **dirty**

---

Other concerns:

- Scroll pumps backing turbo pumps have reduced tip seal lifetime and in general look dirty when servicing.
- Any pump with a vent must be vented outdoors and not into the cave

# Lessons learned – Alignment is critical

---

While not directly related to vacuum, the more closely aligned cryogenic interconnect points are, the easier they are to make up and less likelihood of leaks.

Alignment team now helps set all cryomodules accurately by aligning HGRP and rolling slightly to align beamline connection.





# Lessons learned – F1.3-03 leak

While warming up F1.3-03, the last step is to backfill insulating vacuum (red) with dry nitrogen. A leak on the beamline vacuum (green) system was discovered by pressure following the trend of insulating vacuum.

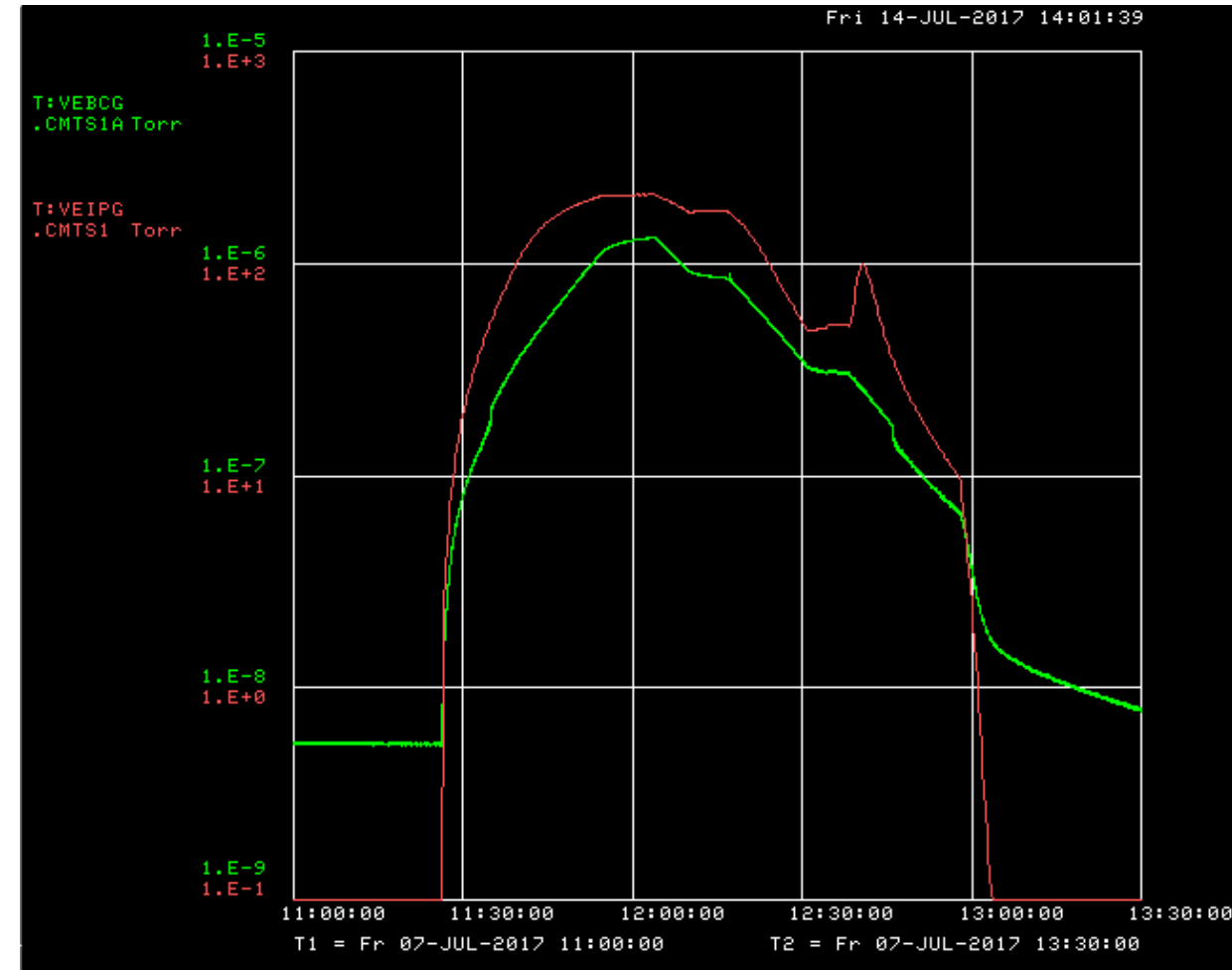

# Lessons learned – F1.3-03 leak

Base RGA scan from earlier in the morning (left) compared to peak pressure (right).

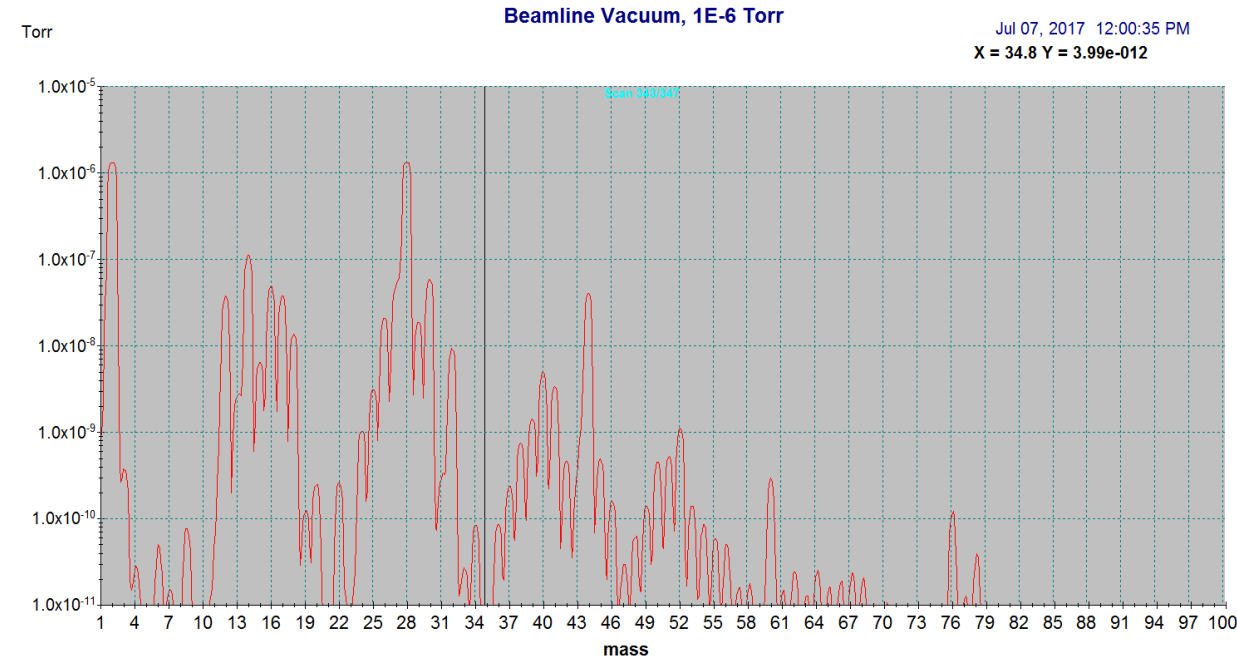
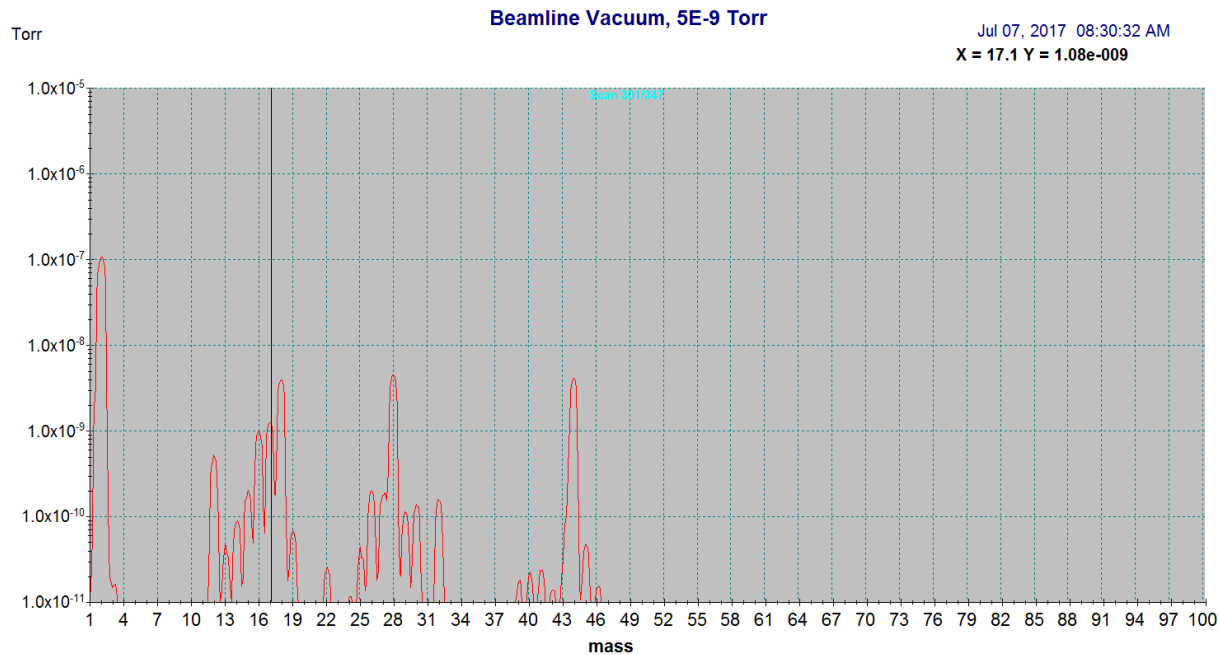

# Lessons learned – F1.3-03 leak

---

Eventually found a  $\sim 1\text{E-}6$  torr-liter/sec leak on the beamline vacuum system in the BPM area.

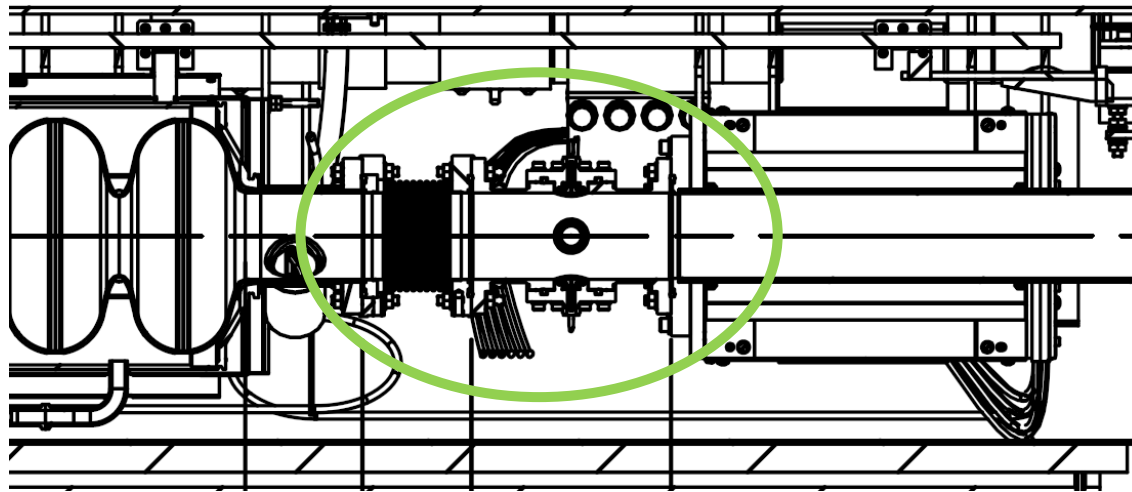

Implemented a check to introduce 5 torr helium at the start of insulating vacuum backfill with RGA running in leak detection mode on beamline vacuum.



# Lessons learned – Coupler vacuum manifold not cleaned

- A supplier switch for LCLS-II-HE meant the coupler pumping manifold came in uncleaned from the vendor whereas with the previous vendor they were ready for UHV assembly.
- Discovered at CMTS when we could not pump down past the mid E-5 torr range with temperature warnings on the ion pump.
- Contamination **does** migrate!

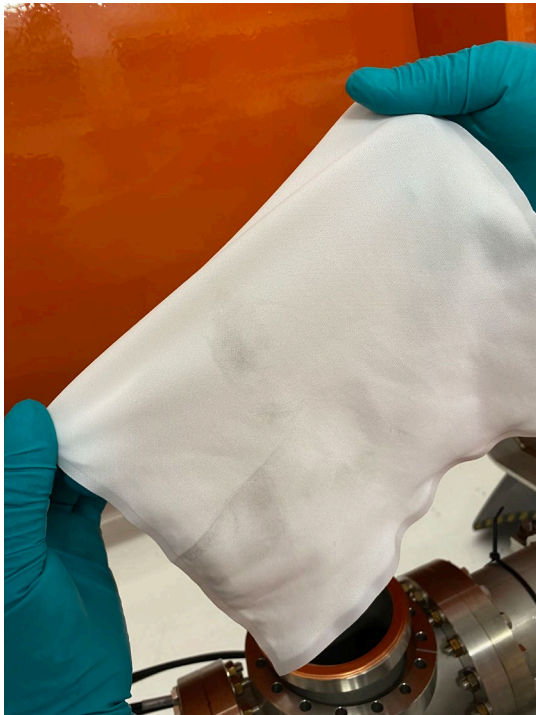

Hartsell | 16 APR 2024 | OLAV VI



# Lessons learned – NEG pump on beamline vacuum

New for LCLS-II-HE, a ZAO alloy NEG pump is installed during the beamline assembly and activated before the string is rolled out of the cleanroom.

- Pressure monitored throughout assembly using the combination ion pump.
- No increase in field emission attributed to pump use and related installation/removal processes.

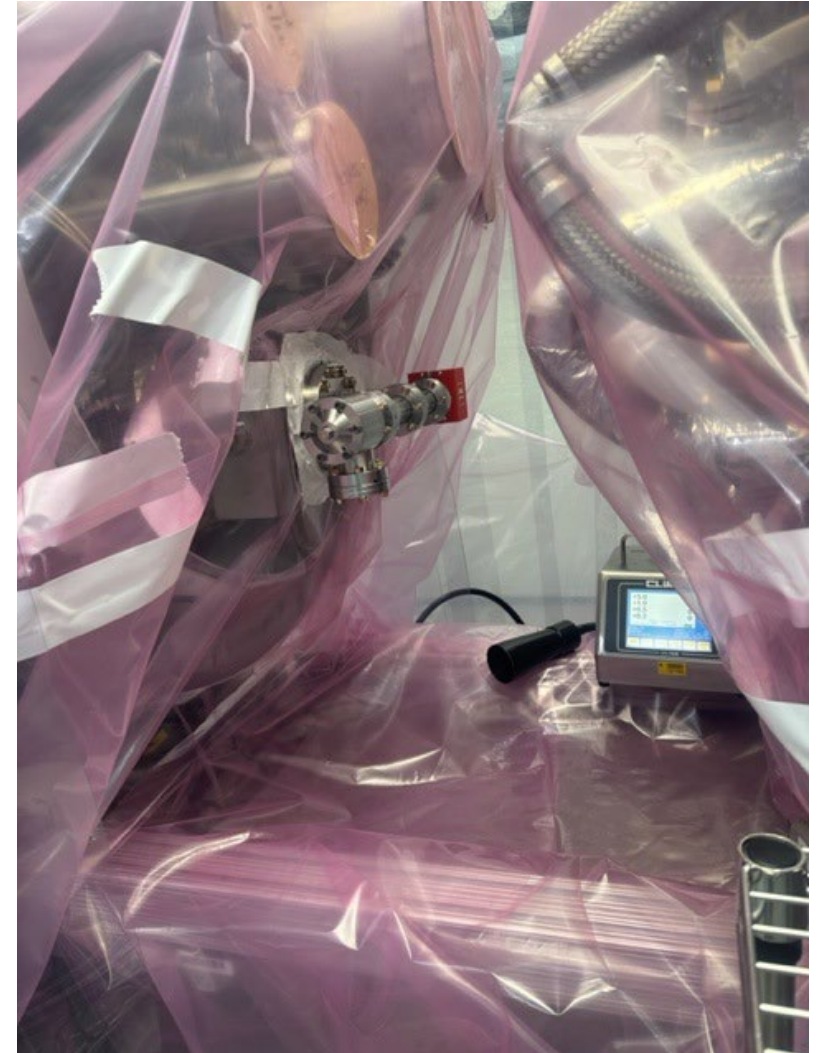

# Wrapping up

---

- We have been testing cryomodules for a while now. For the most part things have gone well, but that doesn't make for a fun presentation.
- A handful of vacuum specific problems have come up over the years.
  - In general, keep it clean and leak check any time you can.
- NEG pumps using ZAO alloy have been working well on beamline vacuum with no field emission attributed to the pump.





# Thank you