

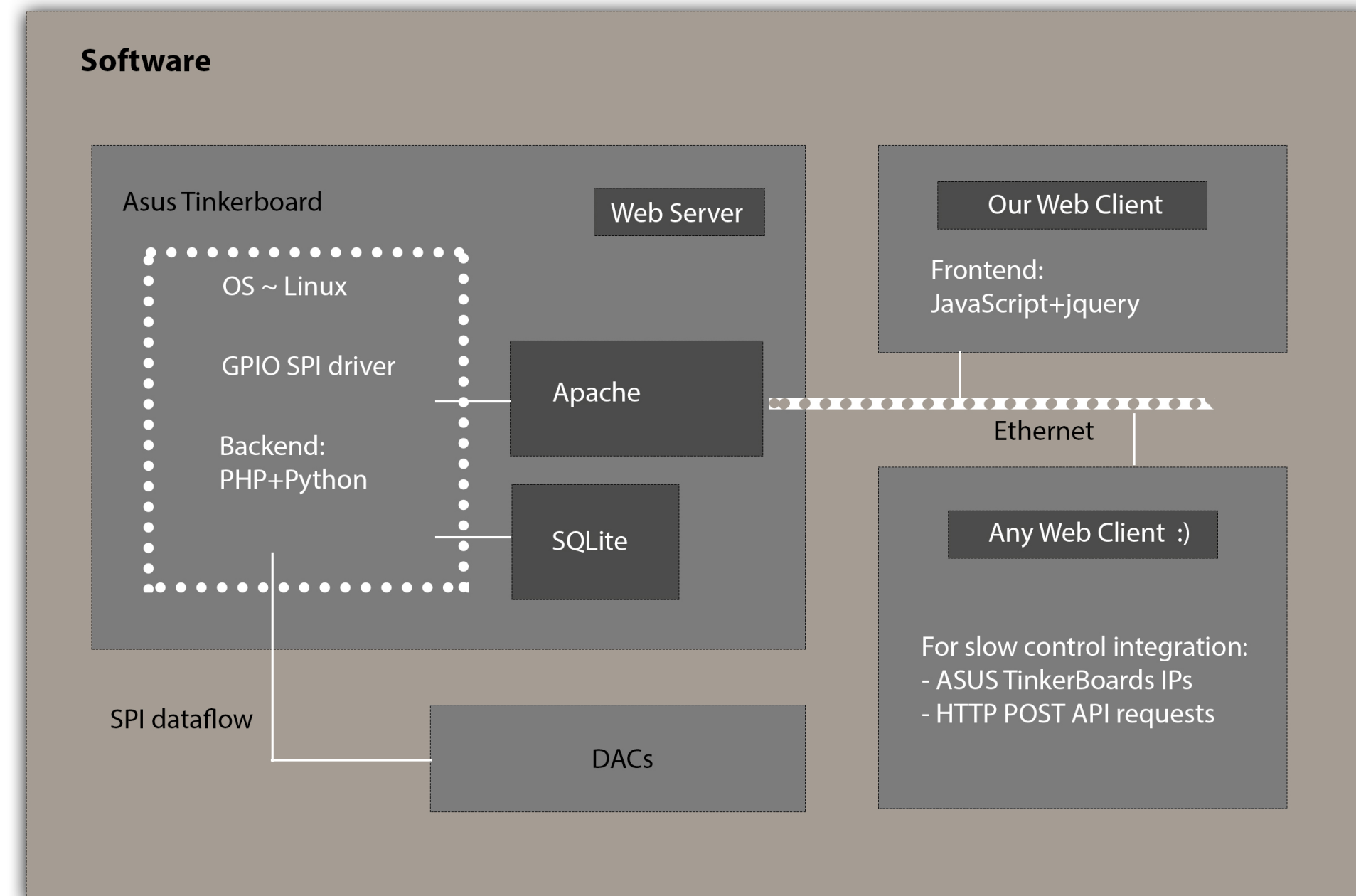

Light Readout system for 2x2

Alexandr Selyunin

Slow control system

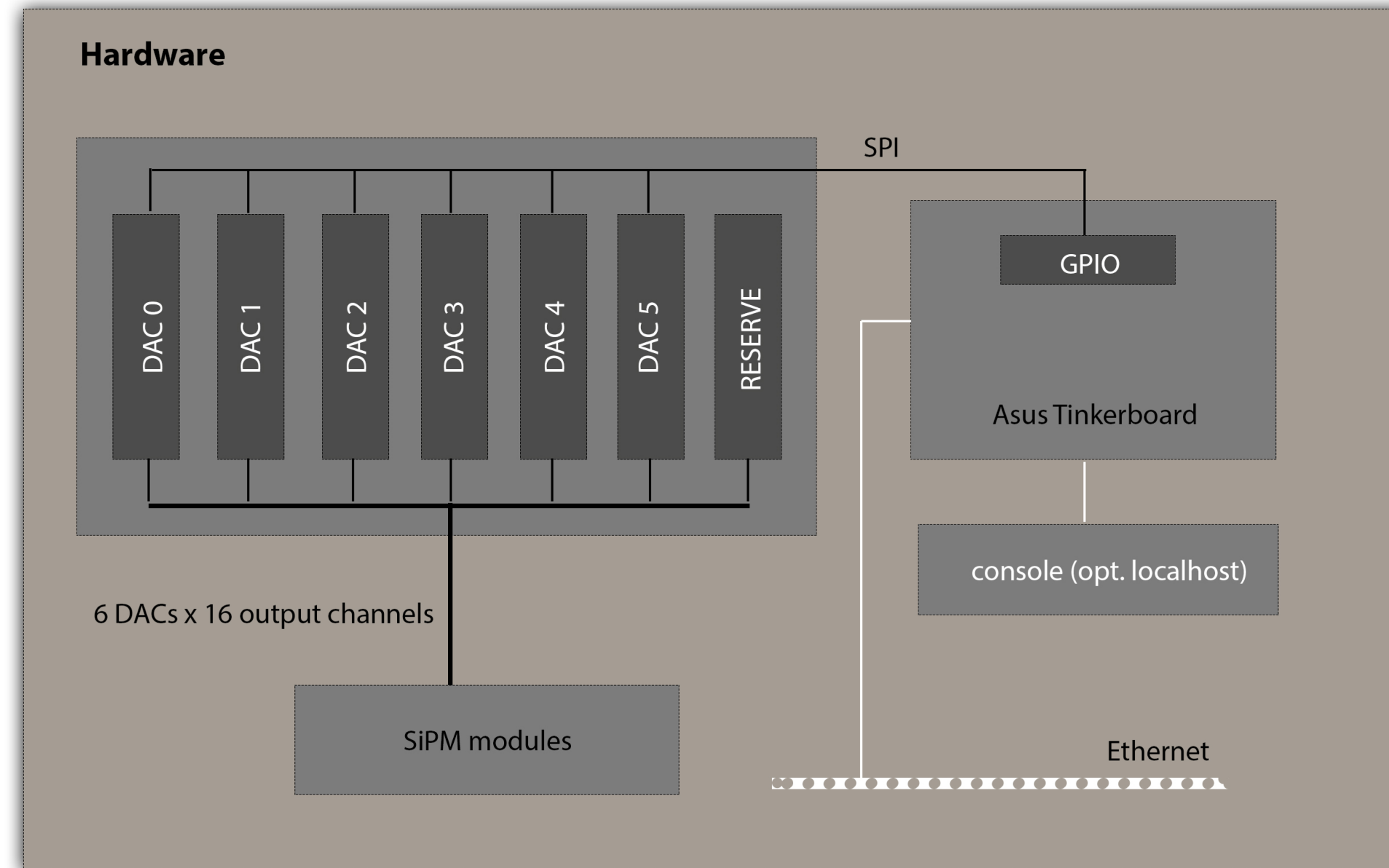

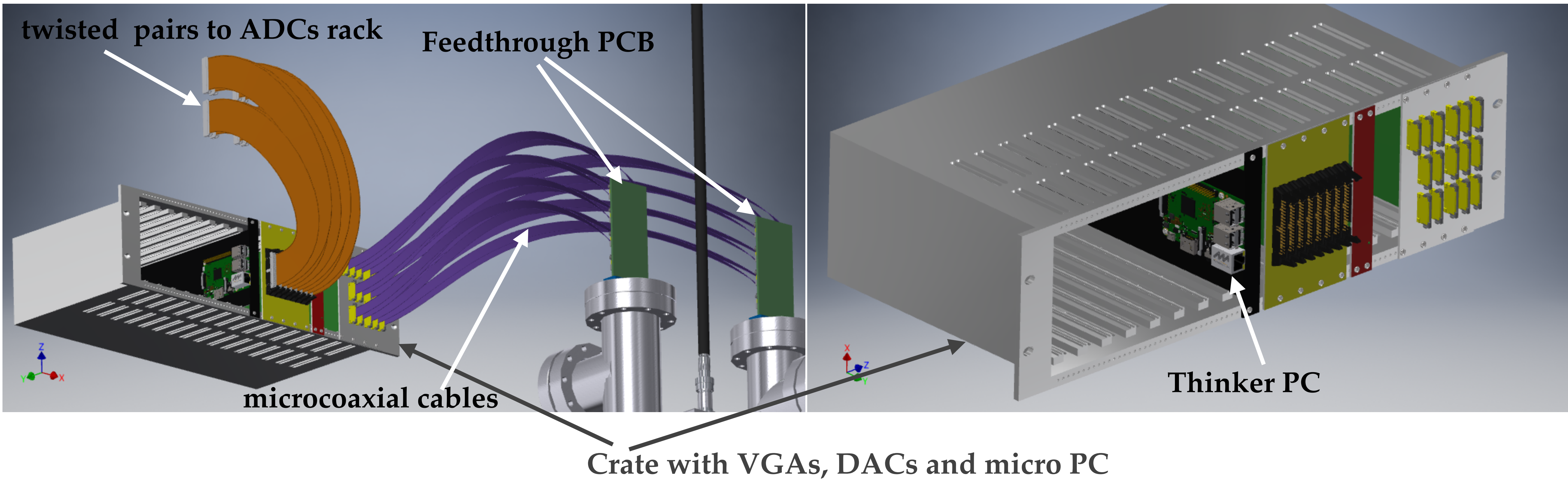

- For 2x2 there are 4 of such the crate. Each has the Thinker board micro PC.
- Thinker PC is connected to switch by means of an optical cable ??? (We have not checked yet an adapter from copper ETH to Optical line (COVID-19))

System distribution

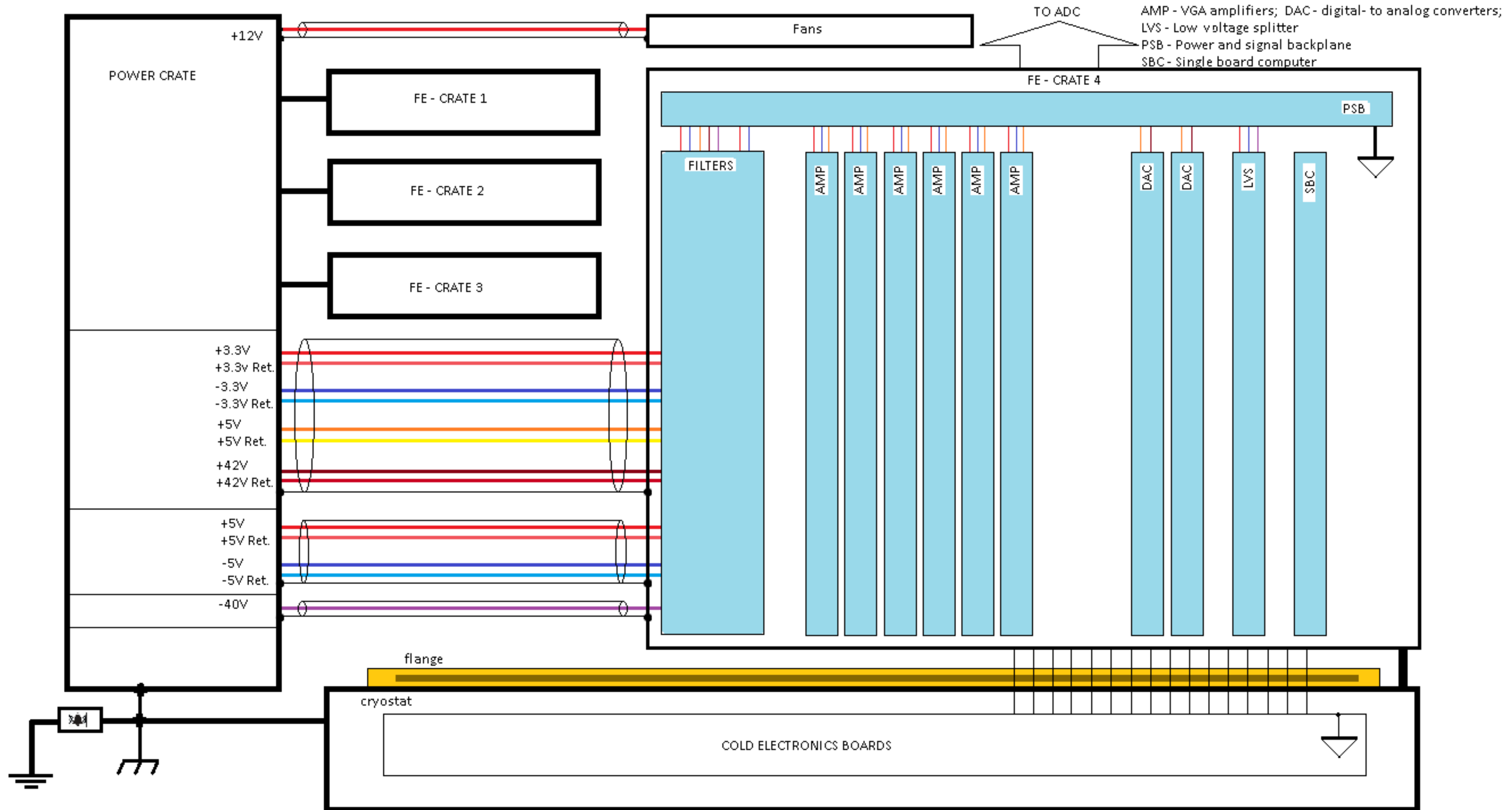

DAC module

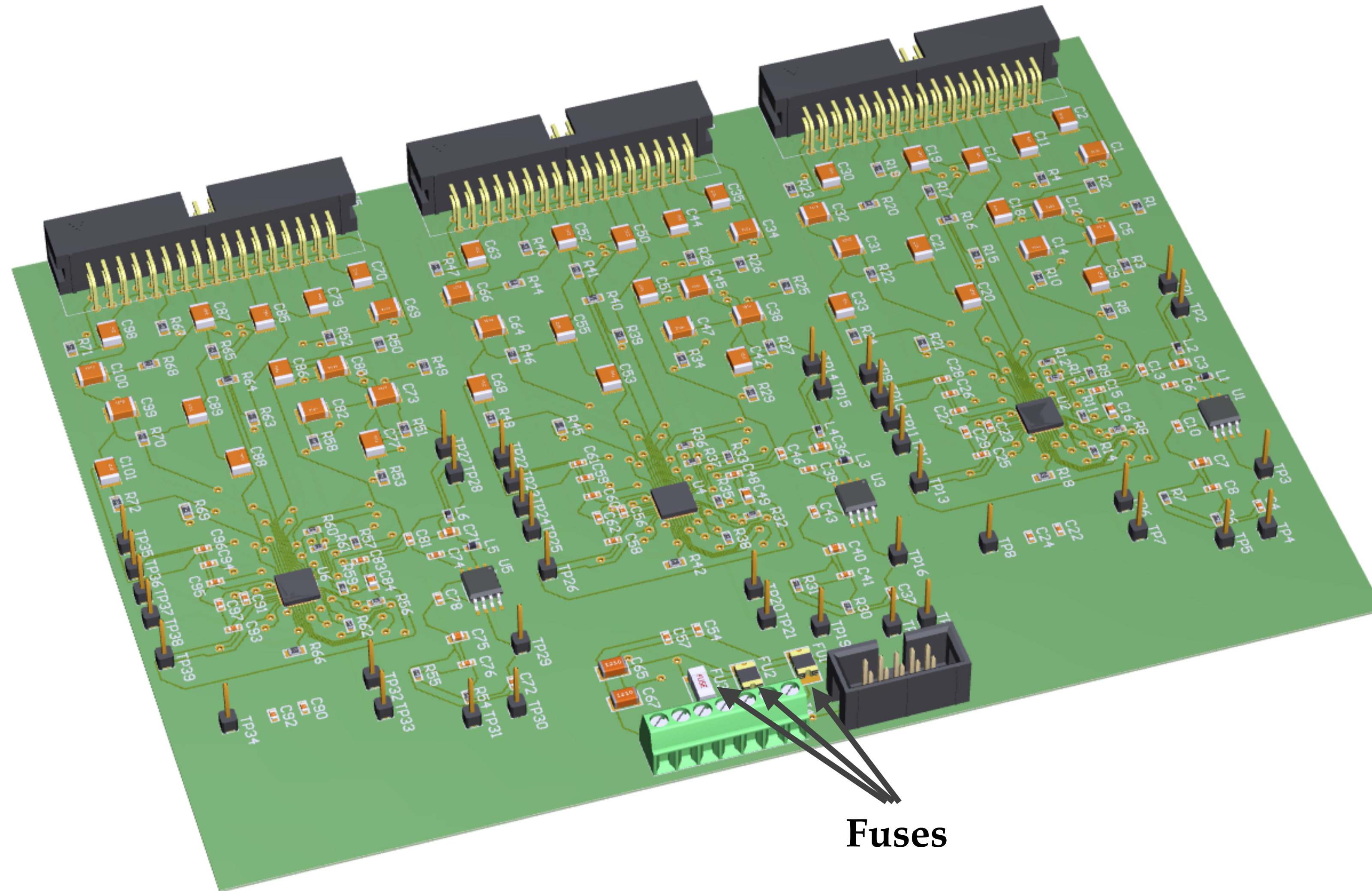

- DAC module (48 CH) based on DAC81416 (16 CH) from Texas Instruments.
3 DAC81416 per module.