

MCP-PMTs FOR DIRC COUNTERS

PANDA AND THE EIC DETECTOR

SNIC 2006

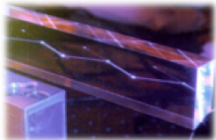
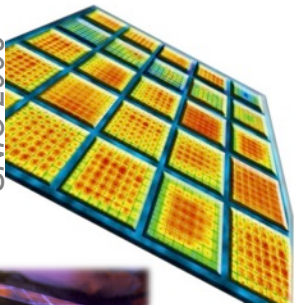

Jochen Schwiening

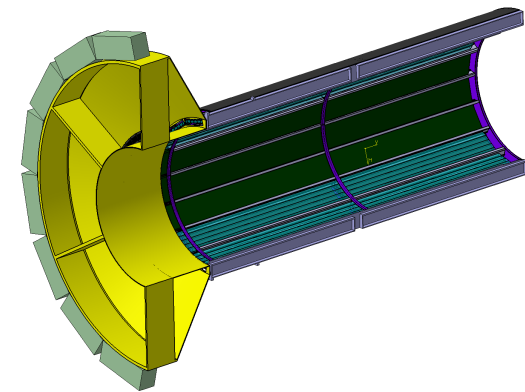
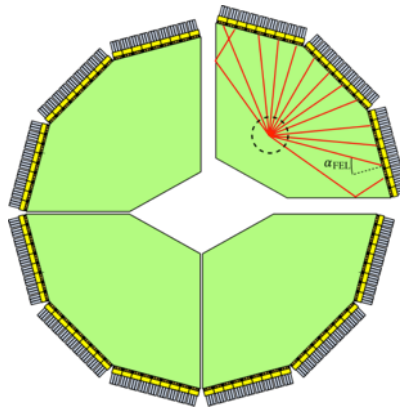
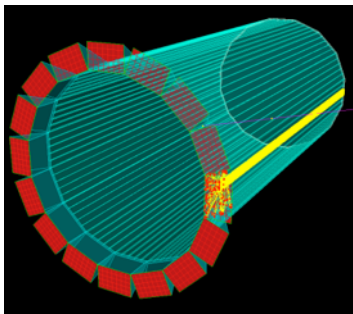
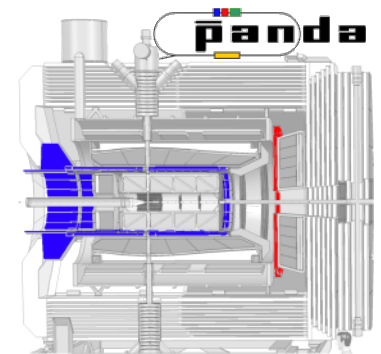

*MCP-PMTs for DIRCs in Belle II, LHCb, and GlueX:
see talks by K. Matsuoka, P. Kapetanopoulos, and C. Zorn*



OUTLINE



DIRC INTRODUCTION

EXPERIENCE WITH DIRCs: BABAR

R&D FOR FUTURE DIRCs

PANDA BARREL DIRC

PANDA DISC DIRC

DIRC FOR EIC CENTRAL DETECTOR

MCP-PMT REQUIREMENTS FOR DIRCs

LIFETIME

OTHER DIRC-SPECIFIC CHALLENGES

*If you've downloaded the file before the talk:
no worries, I will not show all slides...*

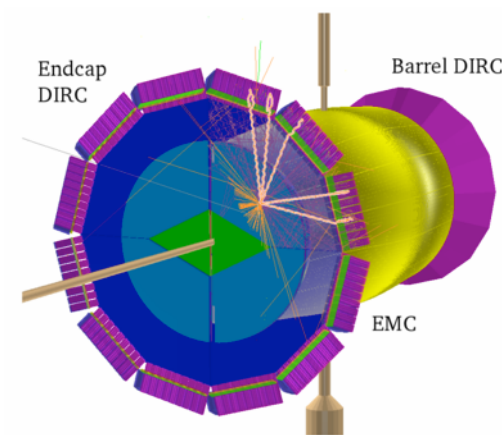
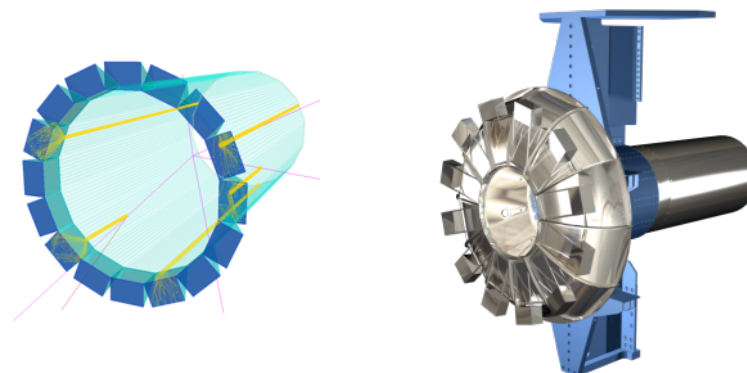
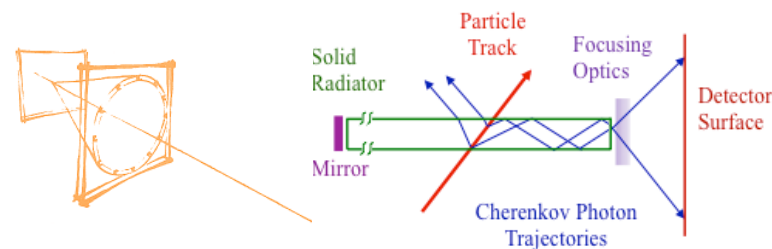



DIRC CONCEPT



- **Charged particle** traversing radiator with refractive index n with $\beta = v/c > 1/n$ emits **Cherenkov photons** on cone with half opening angle $\cos \theta_c = 1/\beta n(\lambda)$.
- For $n > \sqrt{2}$ some photons are always **totally internally reflected** for $\beta \approx 1$ tracks.
- **Radiator and light guide**: bar, plate, or disk made from **Synthetic Fused Silica** (“Quartz”) or fused quartz or acrylic glass or ...
- Magnitude of Cherenkov angle conserved during internal reflections (provided optical surfaces are square, parallel, highly polished)
- Mirror attached to one bar end, reflects photon back to readout end.

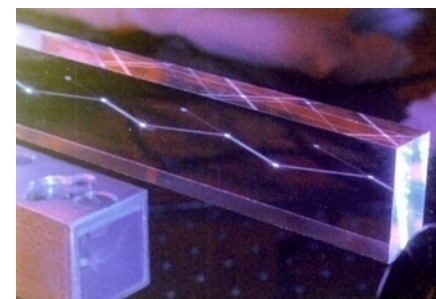
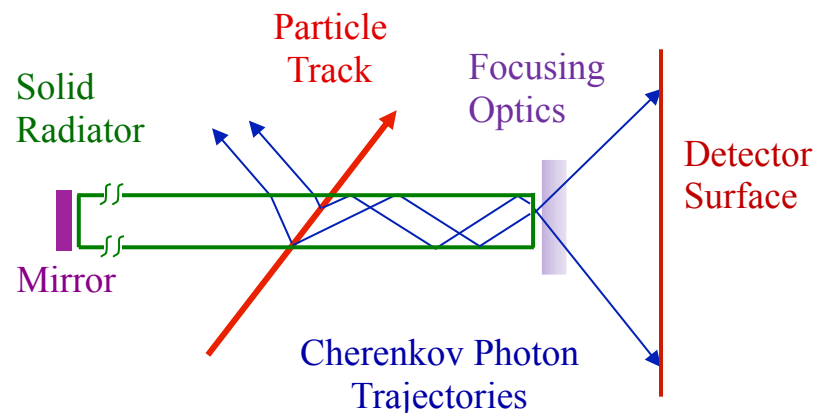



DIRC CONCEPT



- Photons exit radiator via optional **focusing optics** into **expansion region**, detected on **photon detector array**.

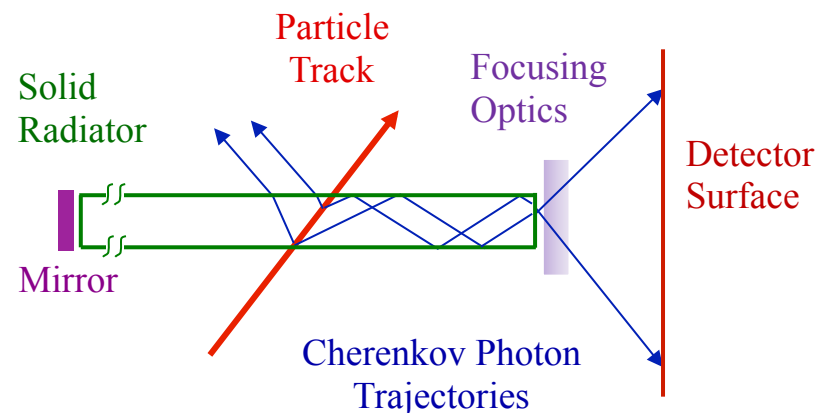

- DIRC is intrinsically a **3-D device**, measuring: **x, y, and time** of Cherenkov photons, defining θ_c , ϕ_c , $t_{\text{propagation}}$.

- **Ultimate deliverable for DIRC: PID likelihoods.**

Calculate likelihood for observed hit pattern
(in detector space or in Cherenkov space)
to be produced by $e/\mu/\pi/K/p$
plus event/track background.



BABAR DIRC PMT Plane



BABAR DIRC TIME LINE



- **1992**: first publication of DIRC concept (Blair Ratcliff).
- 1993-1996: progression of prototypes and DIRC R&D.
- **Nov 1994**: decision in favor of DIRC for hadronic PID for BABAR.
- **Nov 1998**: installed part of DIRC; start of cosmic ray run, commissioning run.
- **April 1999**: BABAR moves into beam line, added 4 more bar boxes.
- **Nov 1999**: all 12 bar boxes installed, start of first physics run.
- **April 2008**: last event recorded with BABAR.

PEP-II peak luminosity: $12.07 \times 10^{33} \text{ cm}^{-2} \text{ sec}^{-1}$ ($4 \times$ design)

BABAR total recorded: $\sim 467\text{M } B\bar{B}$ pairs.

BABAR DIRC ran in factory mode for **8+ years**.

*Detailed review of the BABAR DIRC:
Nucl. Instr. Methods A 538 (2005) 281-357*



BABAR DIRC RECONSTRUCTION



For BABAR DIRC time information provided powerful tool to reject accelerator and event related background.

Calculate expected arrival time of Cherenkov photon based on

- track TOF
- photon propagation in radiator bar and in water

Δt : difference between measured and expected arrival time

± 300 nsec trigger window
(~500-1300 background hits/event)



± 8 nsec Δt window
(1-2 background hits/sector/event)

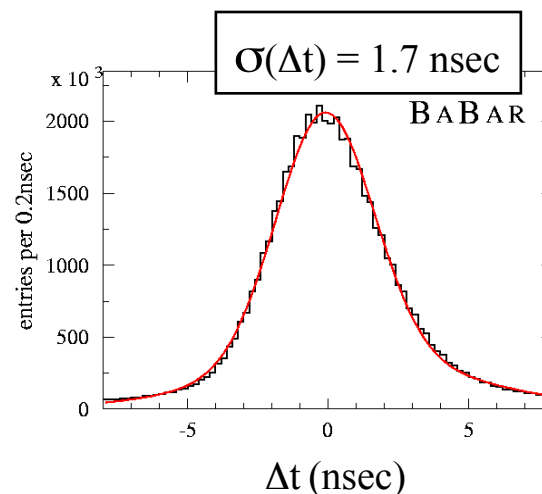
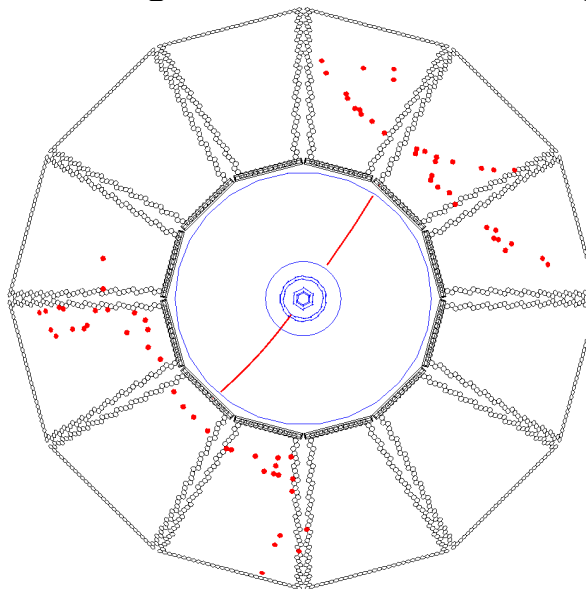
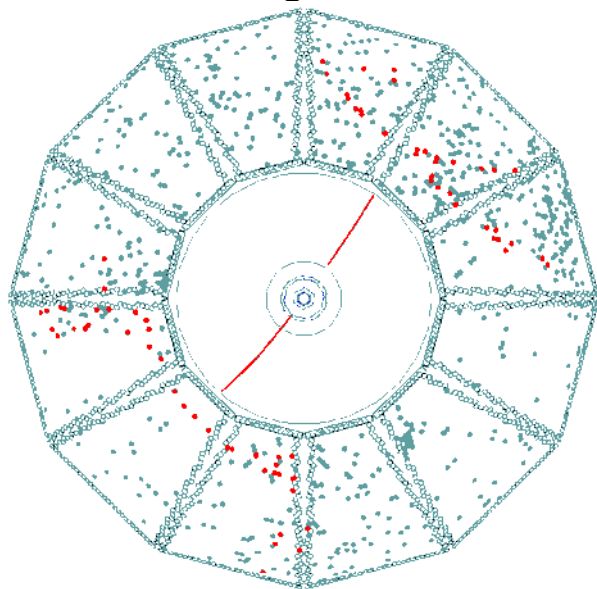

Δt also used to determine event time for “self-triggering” of DIRC.



BABAR DIRC PERFORMANCE



Single photon timing resolution	1.7ns
Single photon Cherenkov angle resolution	~10mrad
Photon yield	20-60 photons per track
Track Cherenkov angle resolution	2.4mrad (di-muons)
π/K separation power	4.3σ @ 3GeV/c, $\sim 3\sigma$ @ 4GeV/c

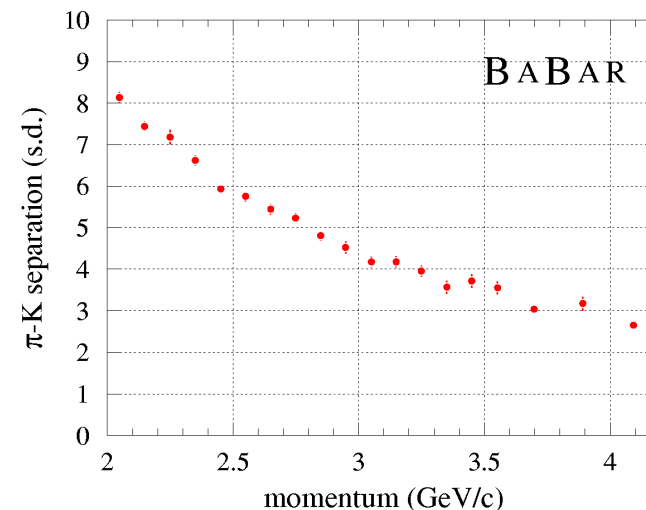
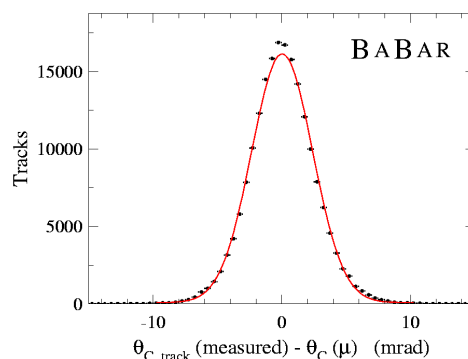
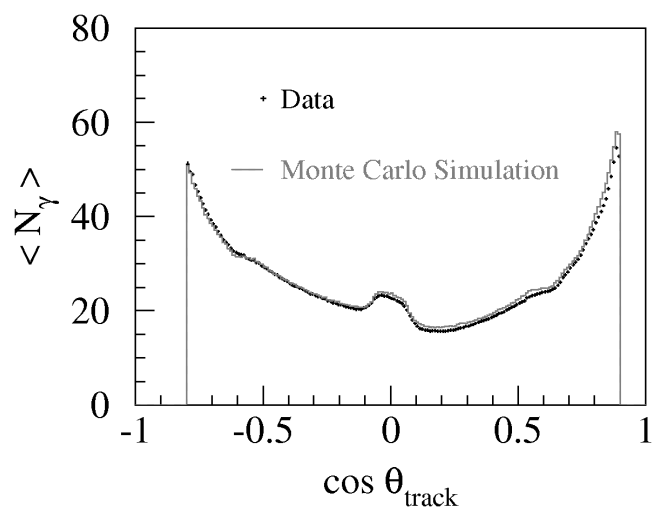

Excellent performance: reliable, robust, easy to operate,
 significant impact on almost all BABAR physics results.
 Fused silica bars in great shape after 15+ years (GlueX, TORCH).



IMPROVING ON BABAR DIRC



The DIRC approach was very successful in BABAR.

As early as 2000 R&D efforts underway to improve future DIRCs.

- Make DIRC less sensitive to background
 - decrease size of expansion volume;
 - use photon detectors with smaller pixels and faster timing;
 - place photon detector inside magnetic field.
- Investigate alternative radiator shapes (plates, disks)
- Push DIRC π/K separation by improving single-photon θ_C resolution
 - focusing optics to reduce bar size contribution;
 - smaller pixels to reduce pixel size contribution;
 - mitigate effect of dispersion using fast timing, filters, etc.

→ R&D for SuperB – Belle II – PANDA (and beyond...)



DIRC LIMITS



$$N_{\sigma} \approx \frac{(m_1^2 - m_2^2)}{(2p^2 \sqrt{n^2 - 1} \sigma[\theta_c(\text{tot})])}. \quad (\text{For momenta well above threshold.})$$

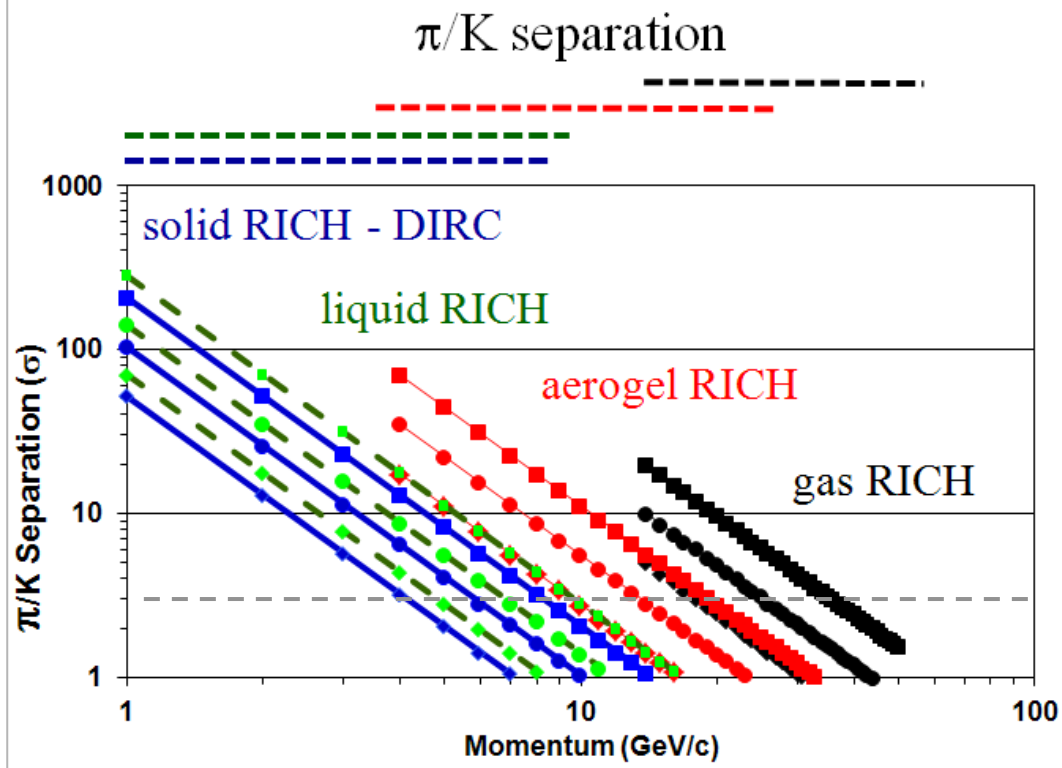

Refractive Indices

- $n=1.473$ (Fused Silica)
- $n=1.27$ (C_6F_{14} CRID)
- $n=1.02$ (Typical Silica Aerogel)
- $n=1.001665$ (C_5F_{12}/N_2 CRID Mix)

← radiator materials

$\sigma[\theta_c(\text{tot})]$

- ◆ 2 mrad
- 1 mrad
- 0.5 mrad

← angular error per track



DIRC provides good π/K separation potential significantly beyond 4 GeV/c.
 Large refractive index limits effective momentum range to below 10 GeV/c.

based on
 B. Ratcliff
 RICH2002



IMPROVING DIRC RESOLUTION

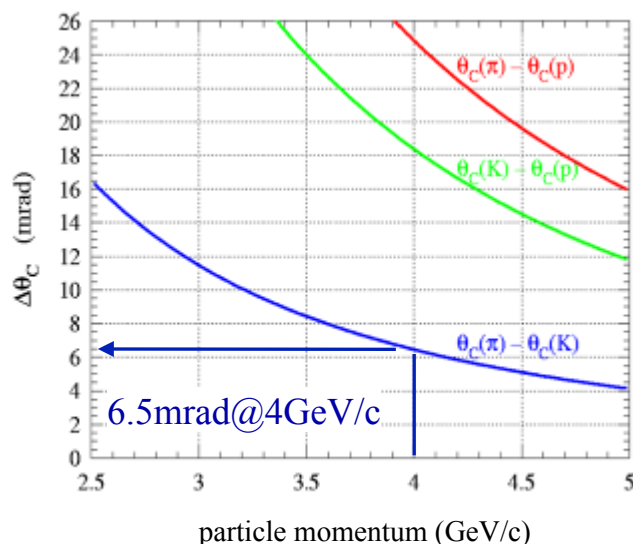

PID performance driven by Cherenkov angle (θ_C) resolution.
Required resolution defined by refractive index of radiator.

Example: π/K separation in synthetic fused silica $\langle n \rangle \approx 1.473$
 \rightarrow 6.5 mrad π/K difference in θ_C at 4 GeV/c;
 \rightarrow need ~ 2.2 mrad resolution for 3 s.d. separation.

Cherenkov angle resolution determined by single photon resolution (scales with $1/\sqrt{N_\gamma}$) and correlated terms (mult. scattering, etc).

R&D ideas to push DIRC 3 s.d. π/K separation limit to higher momenta than BABAR.

BABAR-DIRC Cherenkov angle resolution:

9.6 mrad per photon \rightarrow 2.4 mrad per track

Limited in BABAR by:

- size of bar image ~ 4.1 mrad \dashrightarrow
- size of PMT pixel ~ 5.5 mrad \dashrightarrow
- chromaticity ($n=n(\lambda)$) ~ 5.4 mrad \dashrightarrow

Could be improved for future DIRCs via:

- focusing optics
- smaller pixel size
- better time resolution

BELLE II,
 PANDA & EIC
 DIRC Designs

9.6 mrad \dashrightarrow

4-5 mrad per photon \rightarrow $< 1.5-2$ mrad per track



BABAR DIRC UPGRADE



- In 2000 plans existed for a “Super B-Factory” at SLAC.
 - Super-PEP-II upgrade of accelerator and IR for 100x higher luminosity.
 - Super-BABAR upgrade: improve physics performance, allow safe operation at high luminosity.
- BABAR DIRC SLAC group started R&D to push DIRC π/K separation power to higher momentum and reduce sensitivity to backgrounds.
- DIRC R&D effort at SLAC (led by J. Va’vra) concentrated on:
 - using **focusing mirror** to reduce contribution of bar size to θ_c resolution;
 - mitigating effect of **chromatic dispersion** using **fast photon timing**.
 - **decreasing volume of stand-off box** by factor 10;
- Started with R&D on compact multi-pixel photon detectors (Hamamatsu MaPMTs and Burle MCP-PMTs), progressed with multi-bar prototypes in cosmic ray telescope facility and test beams, including complex readout electronics R&D.
- Resulted in FDIRC design for SuperB in Italy.

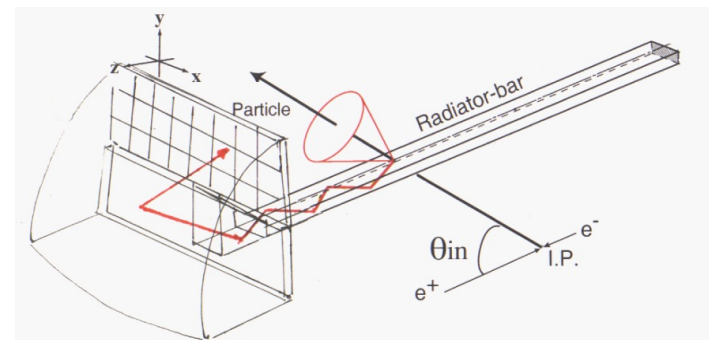

*New comprehensive overview of Super FDIRC R&D
J. Va’vra et al., SLAC-PUB-16112 (Oct. 2014), submitted to NIM A*

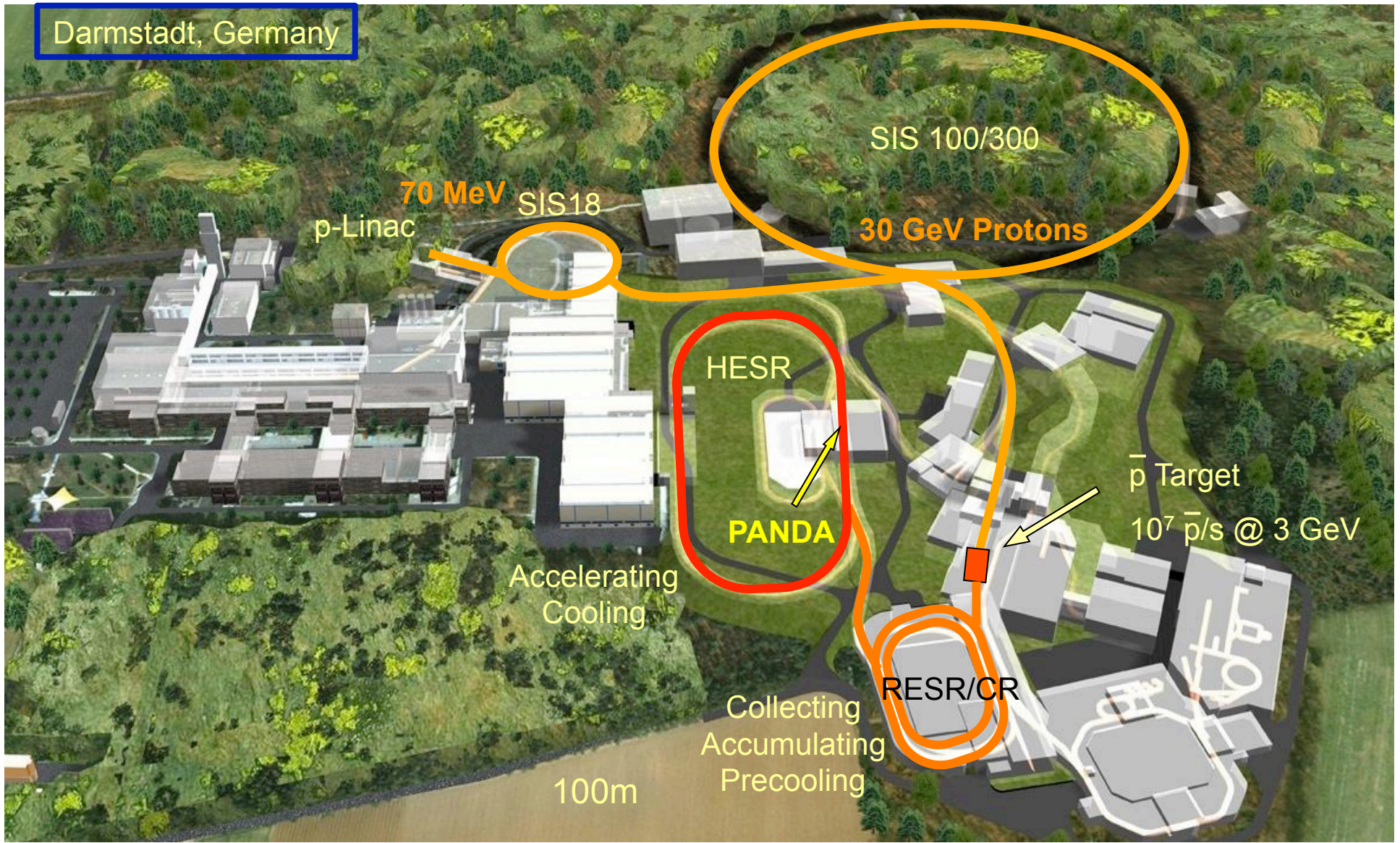

Darmstadt, Germany



Site webcam (from today)

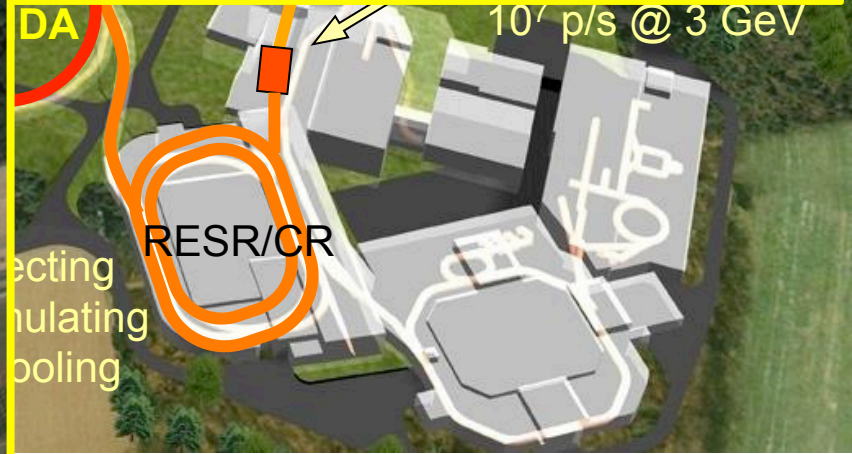

Google Maps view
(aerial photo taken Dec 2013)

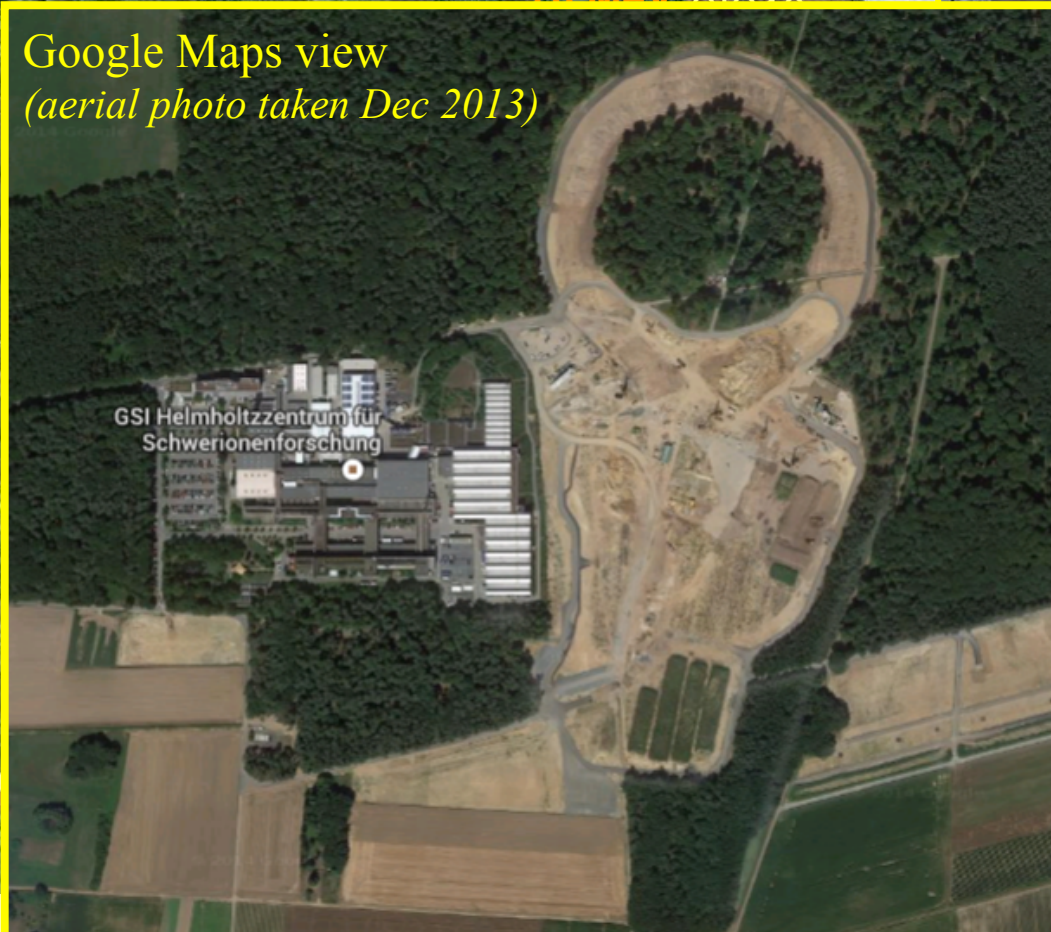

Study of QCD with Antiprotons

- **Charmonium Spectroscopy**
 - Precision Spectroscopy
 - Study of Confinement Potential
 - Access to all these puzzling X, Y and Z
- **Search for Exotics**
 - Look for Glueballs and Hybrids
 - Gluon rich environment → high discovery potential
 - Disentangle Mixing via PWA
- **Hadrons in Medium**
 - Study in-medium modification of Hadrons
- **Nucleon Structure**
 - Generalized Parton Distribution
 - Timelike Form Factor of the Proton
 - Drell-Yan Process
- **Hypernuclear Physics ... and more**

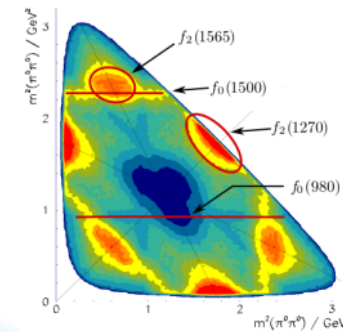

K. Götzen
TROIA '09

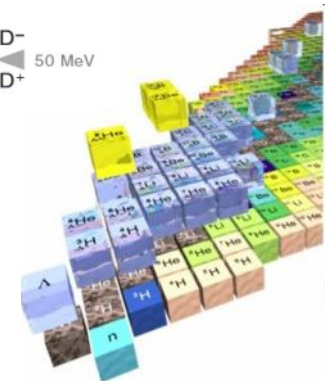
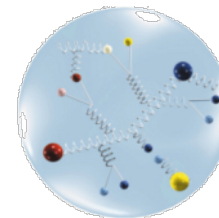
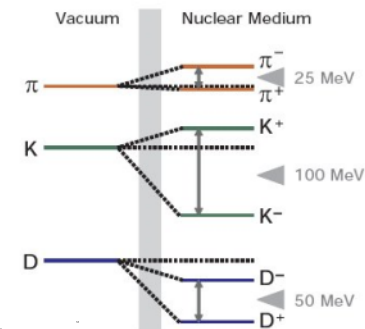
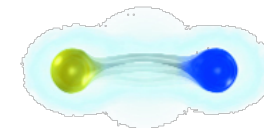

Excellent particle identification required.

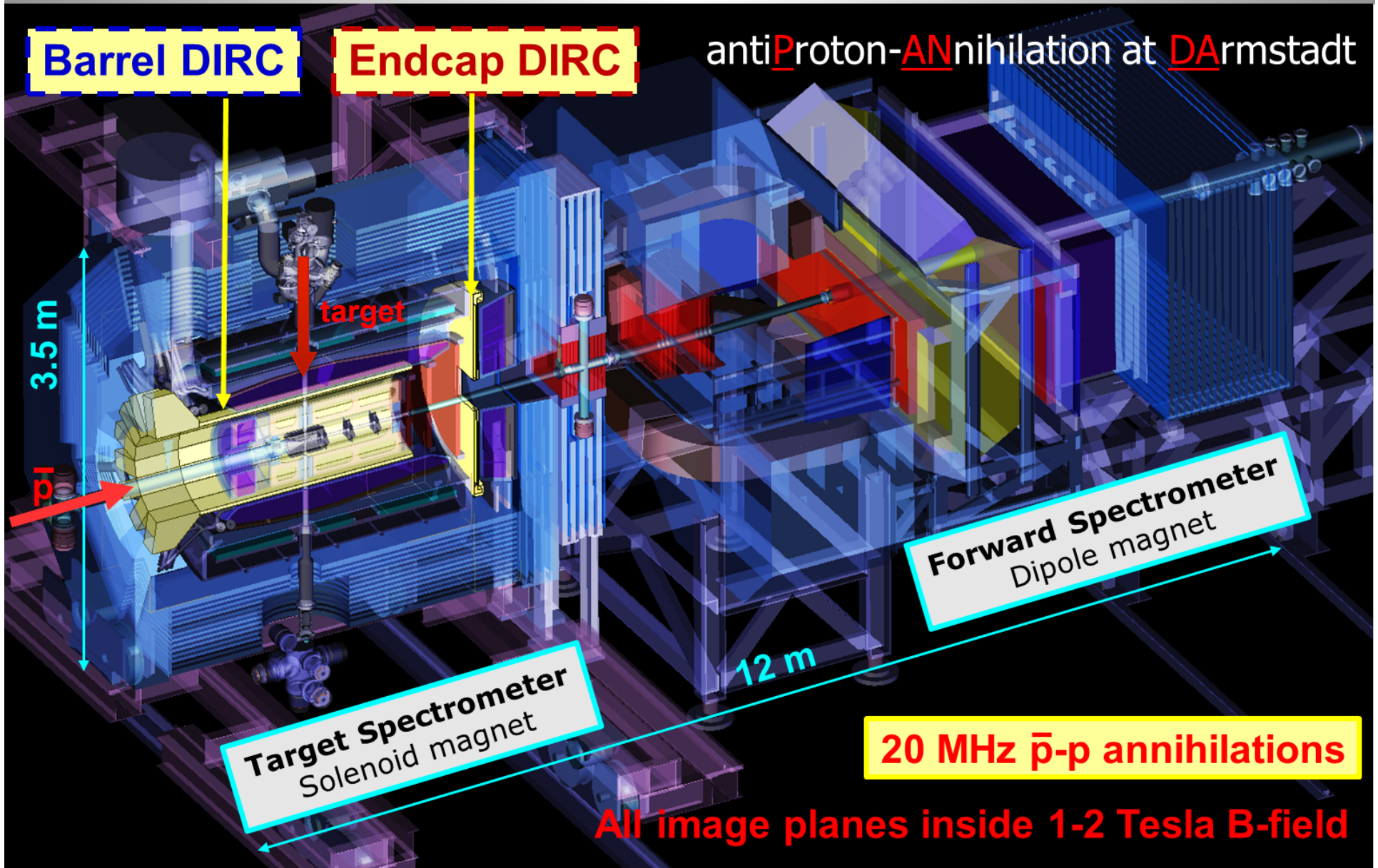

PANDA: two DIRC detectors

- Barrel DIRC

German in-kind contribution to PANDA

PID goal: 3σ π/K separation for $p < 3.5$ GeV/c.

- Endcap Disc DIRC

PID goal: 3σ π/K separation for $p < 4$ GeV/c.

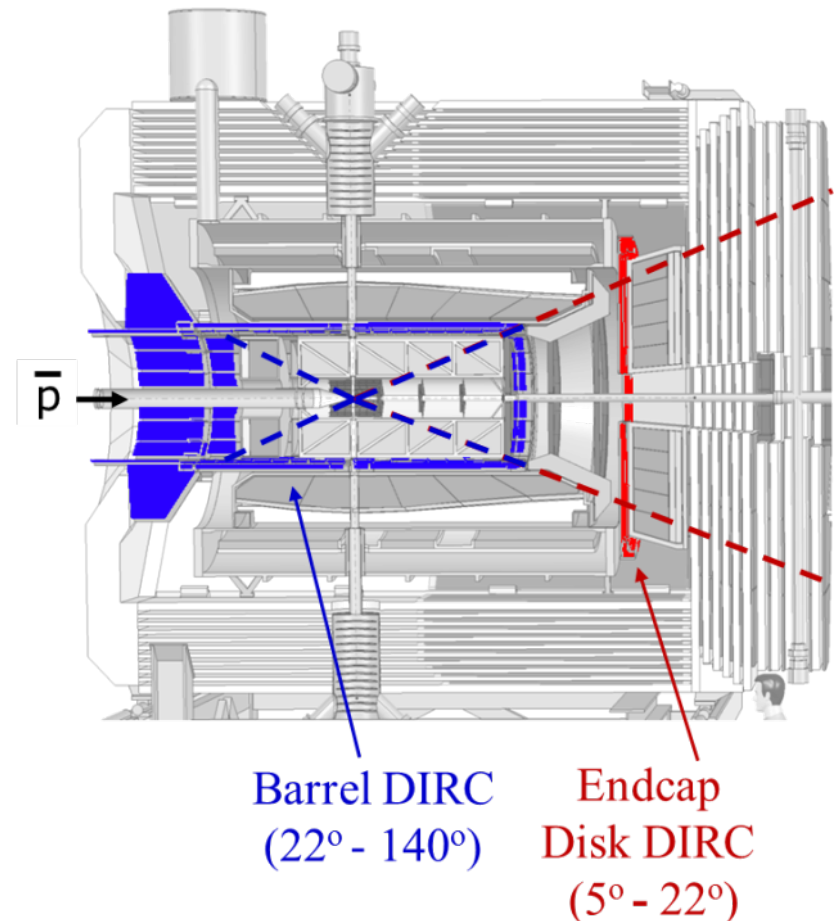

PANDA Cherenkov Group:

JINR Dubna, FAU Erlangen-Nürnberg, JLU Gießen, U. Glasgow,
GSI Darmstadt, HIM and JGU Mainz, SMI OeAW Vienna.

Thanks for the material provided for this talk.

PANDA: two DIRC detectors

- Barrel DIRC

German in-kind contribution to PANDA

PID goal: 3σ π/K separation for $p < 3.5$ GeV

- Endcap Disc DIRC

PID goal: 3σ π/K separation for $p < 4$ GeV/c.

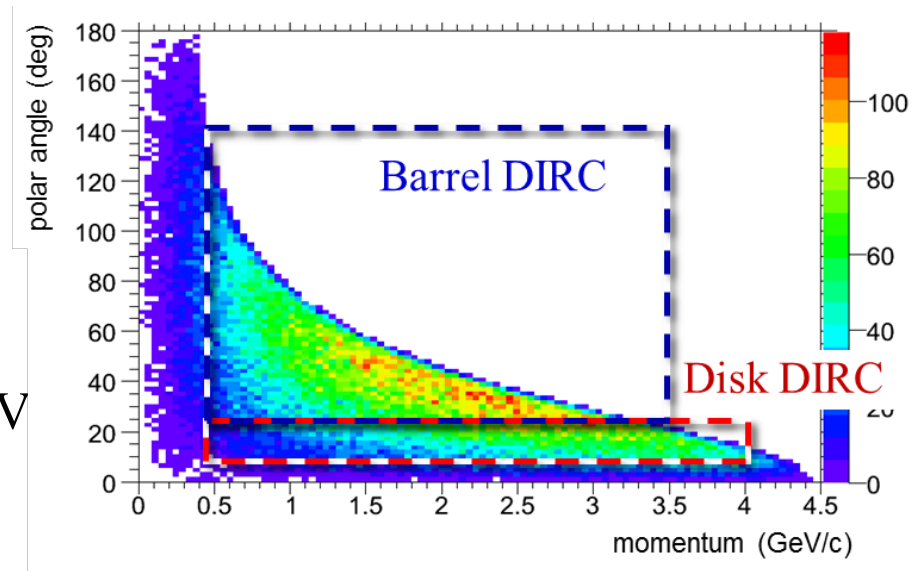

Kaon distribution of the radiative decay

$J/\psi \rightarrow K^+K^-\gamma$
(search of glue balls)

Best barrel DIRC performance required at steep forward angles
(highest momenta for most physics channels of interest).

Good match to DIRC technology:

larger photon yield at steep angles (longer path in fused silica).

Highest momentum particles and about half the tracks per event seen by Disc DIRC.

Baseline design: based on BABAR DIRC with key improvements

- Barrel radius ~ 48 cm; expansion volume depth: 30 cm.
- 80 narrow radiator bars, synthetic fused silica
17mm (T) \times 32mm (W) \times 2400mm (L).
- **Focusing optics:** lens system.
- **Compact photon detector:**
30 cm oil-filled expansion volume
 $\sim 15,000$ channels of MCP-PMTs
in ~ 1 T B field.
- **Fast photon detection:**
fast TDC plus ADC (or ToT) electronics.
- **Expected performance:**
Single photon Cherenkov angle resolution: 8-10 mrad.
Number of photoelectrons for $\beta \approx 1$ track: at least 20.

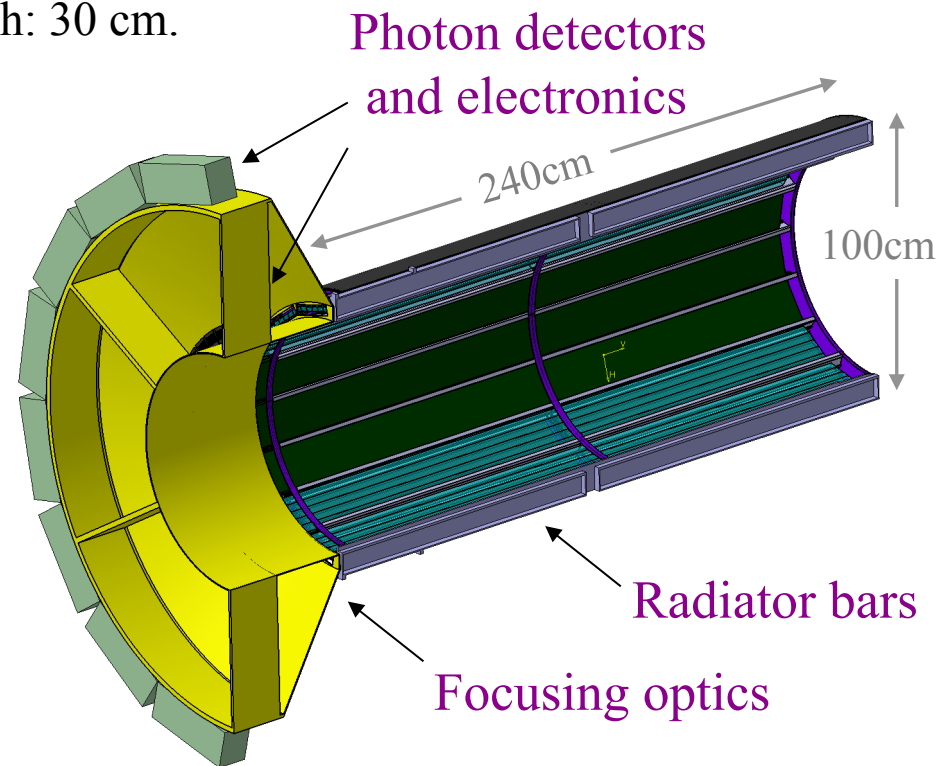

*Validate design/options in 2015,
TDR by mid-2016.*

Investigating several **design options**:

Use of one **wide fused silica plate** (16cm) per sector instead of 5 narrow (3.2cm) bars

Belle II iTOP is leading the way with plate fabrication, prototyping, and software development.

Smaller number of pieces would **drastically reduce the radiator fabrication cost** (1.5M€+ savings possible).

Our Barrel DIRC would still be keep large number of pixels, more robust operation, timing less critical.

Segmented optical expansion volume: **“camera”**

one solid **fused silica prism** per sector instead of oil tank

→ **better optical and operational properties**, good match to wide plates.

But: reflections in prism complicate reconstruction for narrow bars, add background.

Design also **reduces the number of required MCP-PMTs**.

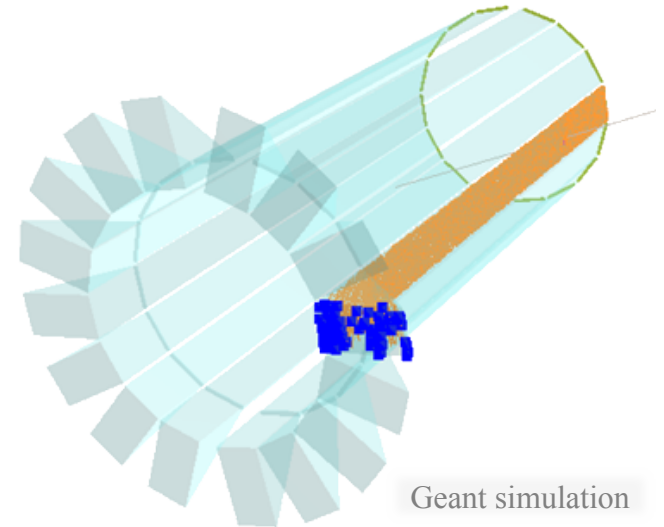

Emphasis on validating sensors and optics

Detailed simulation to define requirements, optimize reconstruction (bars/plates).

- Radiator prototype program with industry partners in Europe, USA, Japan;
~30 bars/plates produced by 6 companies using different materials and techniques.
- Two solid fused silica prism prototypes (30° and 45° top angle) built by industry.
- Designed several spherical and cylindrical lenses, with and without air gap, built by industry.
- Optical lab and particle beams to test performance.
- Tested DIRC sensor properties, including lifetime.

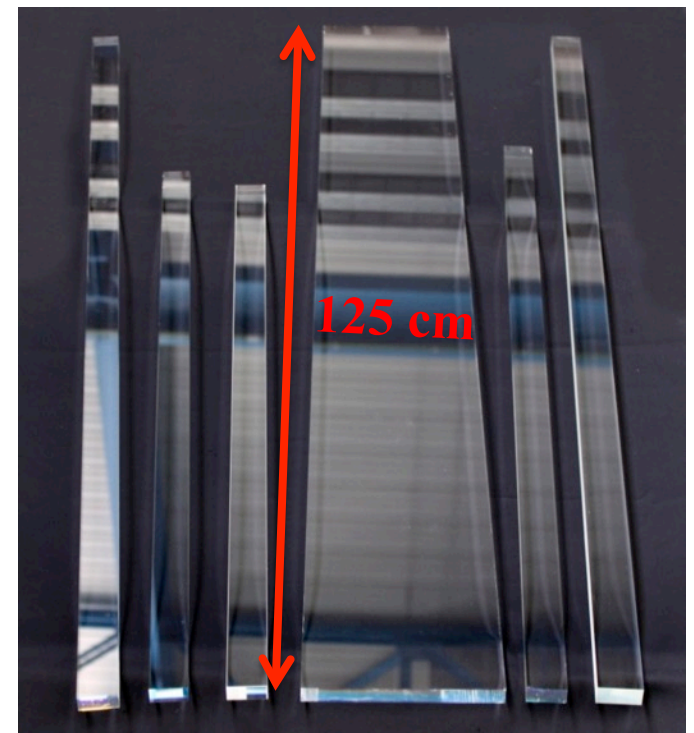
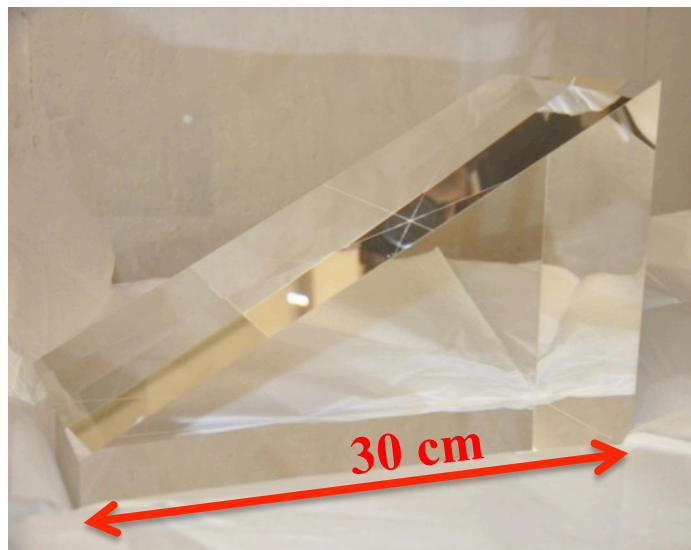
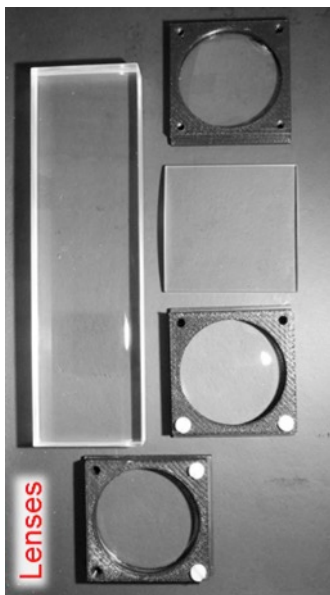

Increasingly complex prototypes tested with particle beams in 2008, 2009, 2011, 2012, 2014

2012

Prototype with **narrow bars**
 CERN PS
 mixed hadron beam 1 – 10 GeV/c

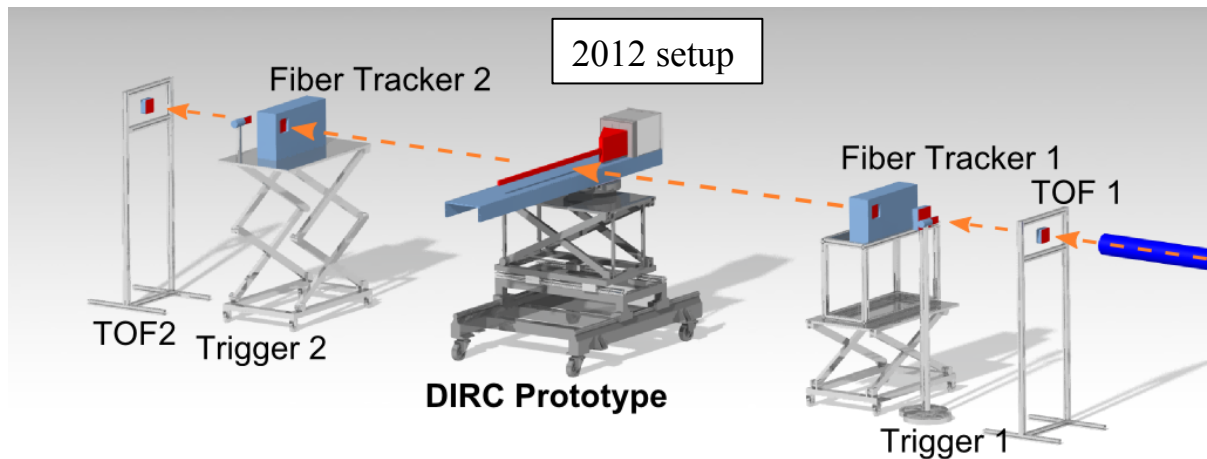

Determined **photon yield** and **single photon Cherenkov angle resolution** for different bars and focusing optics over wide angular range.

First tests with **fused silica prism** and **wide plate**.

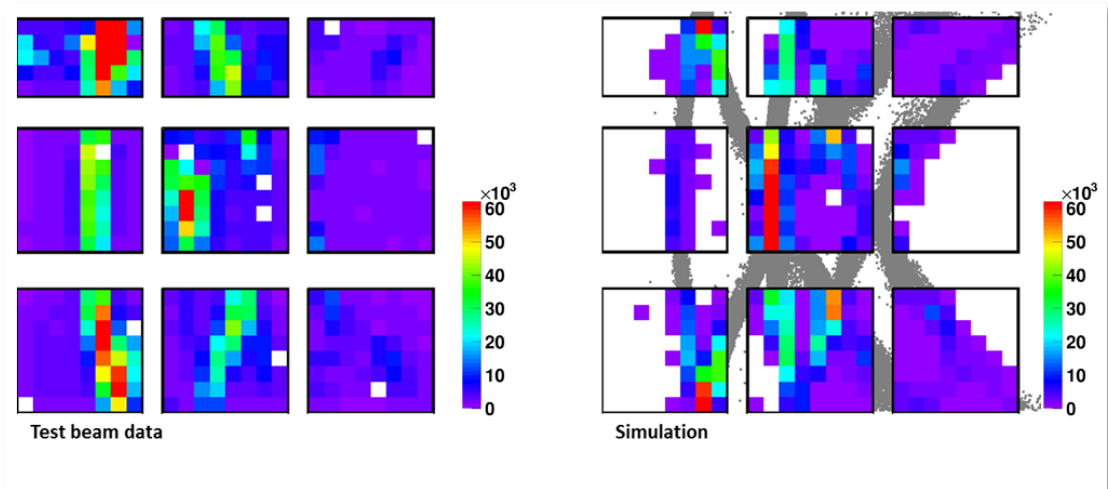

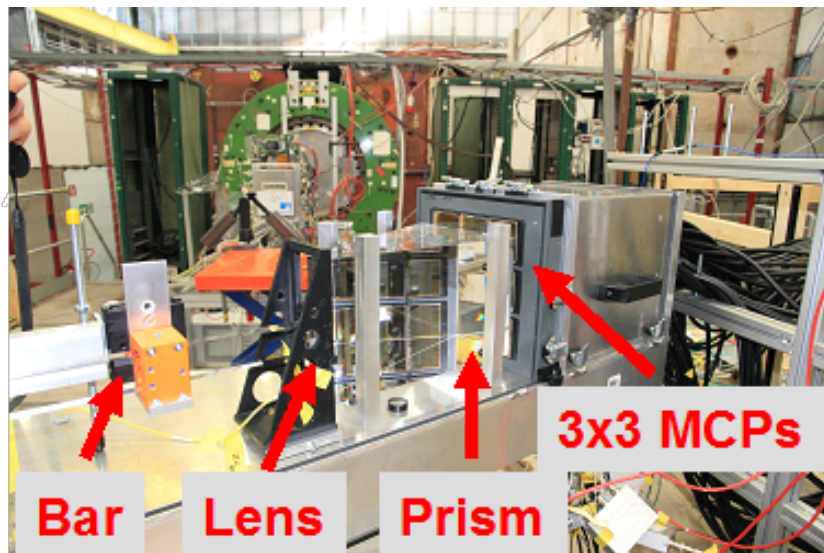
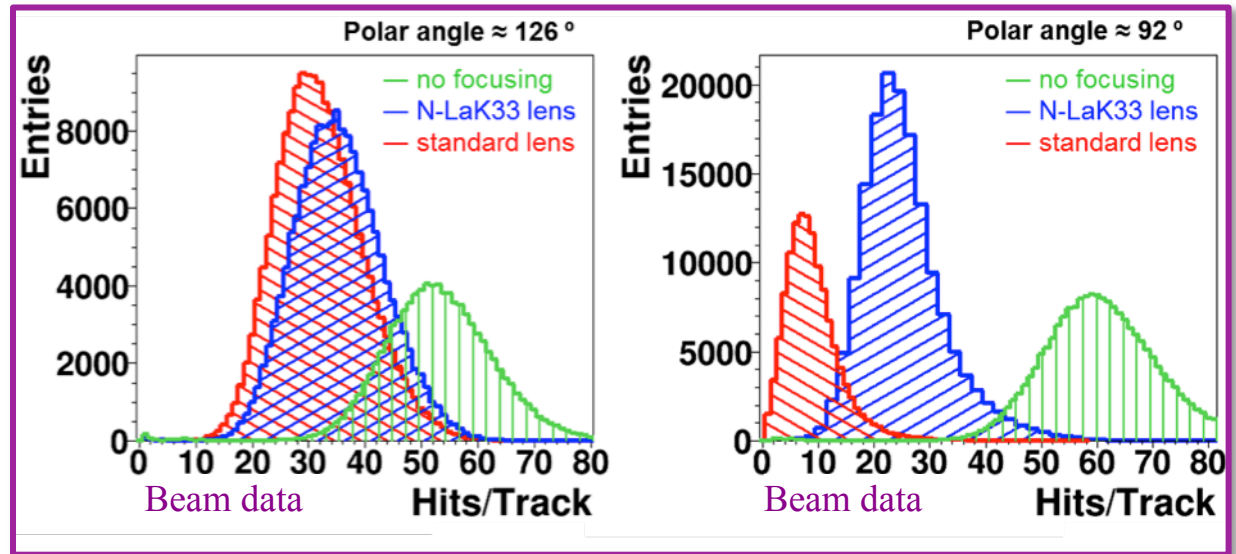
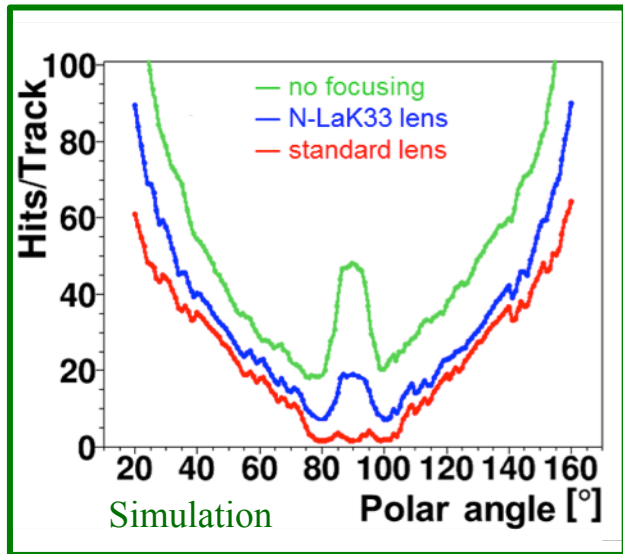

2012

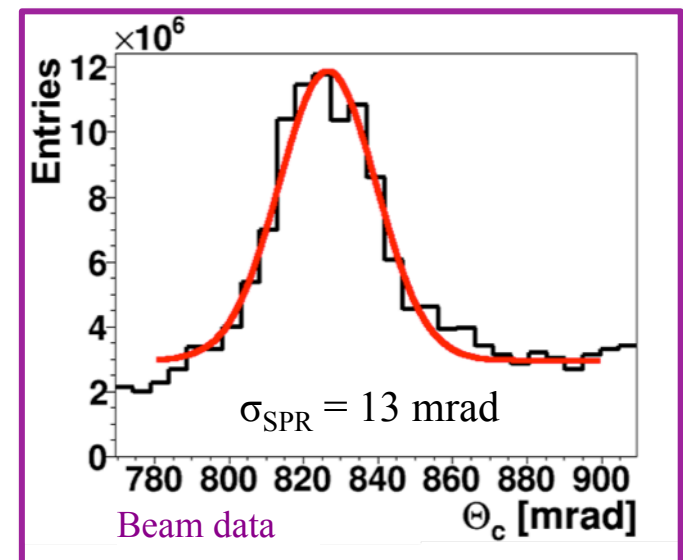

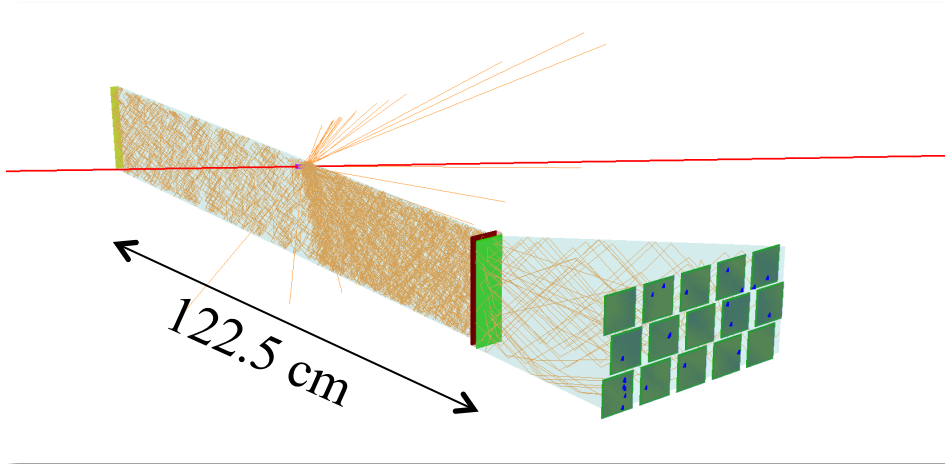

Beam time at GSI; 5 weeks in summer 2014

- 2014 prototype is similar to a module of the final detector
- 5 x 3 array PHOTONIS Planacon MCP-PMT
- 960 pixels (in total >1200 readout channels)
- Wide plate w/ and w/o focusing lens
- Narrow bar with different lenses
- Run ended in September
- Calibration/simulation/analysis ongoing

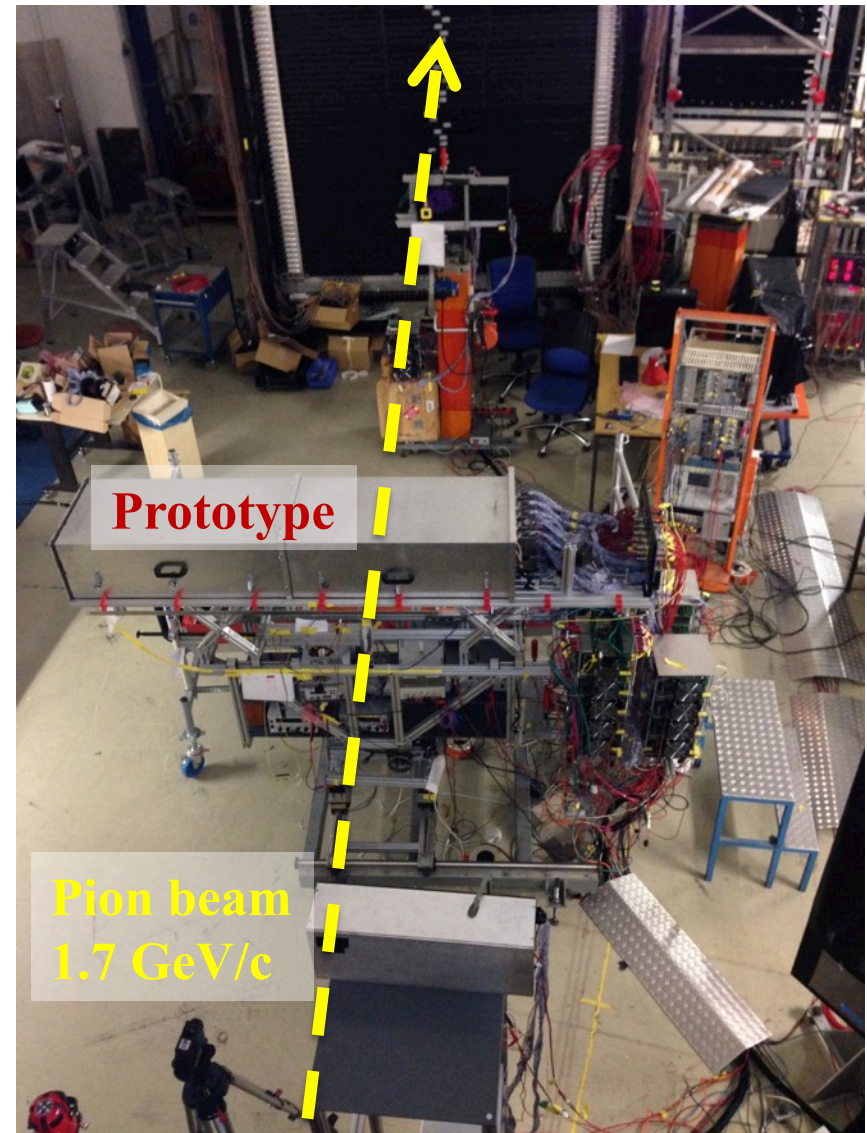

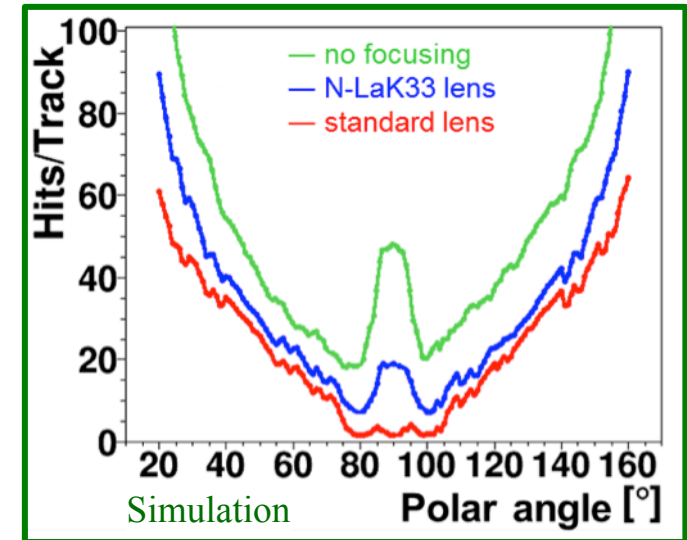
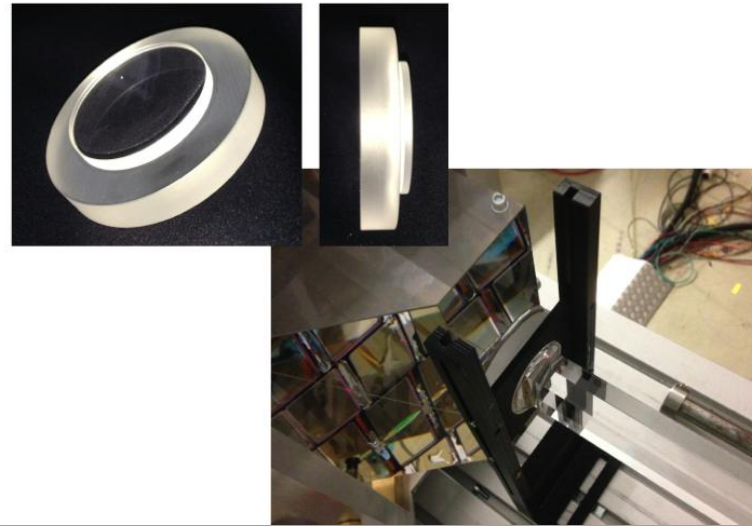
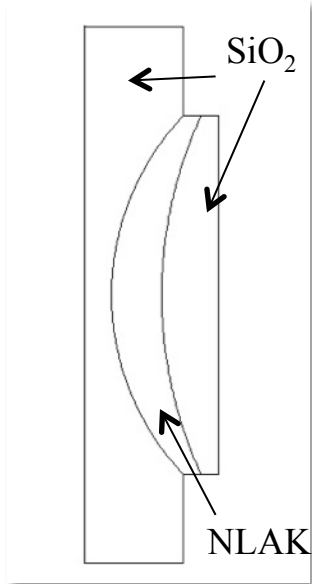

Narrow Bar Data (36mm width)

New **3-component lens** with better focusing and no air gap to reduce photon loss (**synergy with DIRC@EIC**)

No comparison with simulation yet but data show typical folded DIRC “ring” structure.

Beam data, 125 deg:

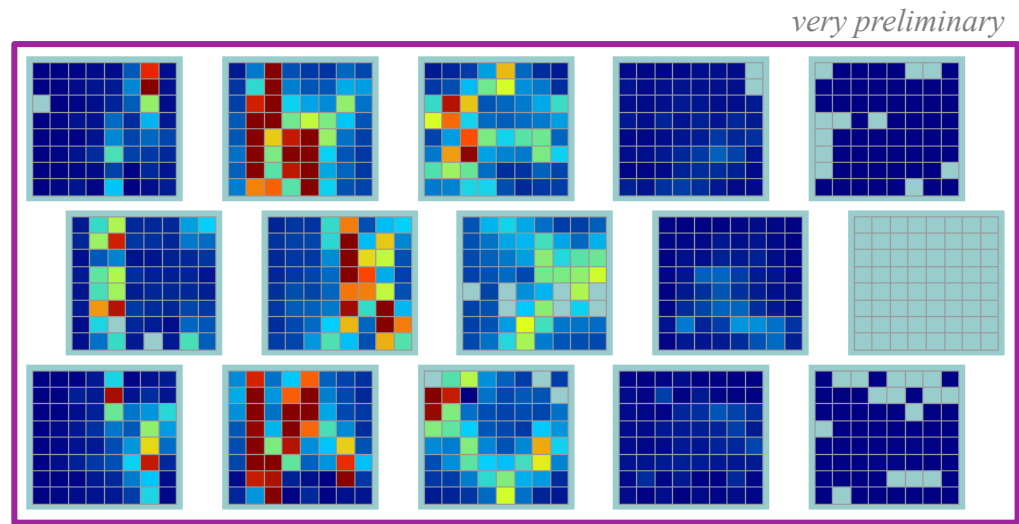

Wide Plate Simulation (175mm width)

Geant 4

pixelated:

Radiator plate
Cylindrical lens (no air gap)
Prism EV (45° top angle)

120° polar angle
1.7 GeV/c pions

true locations:

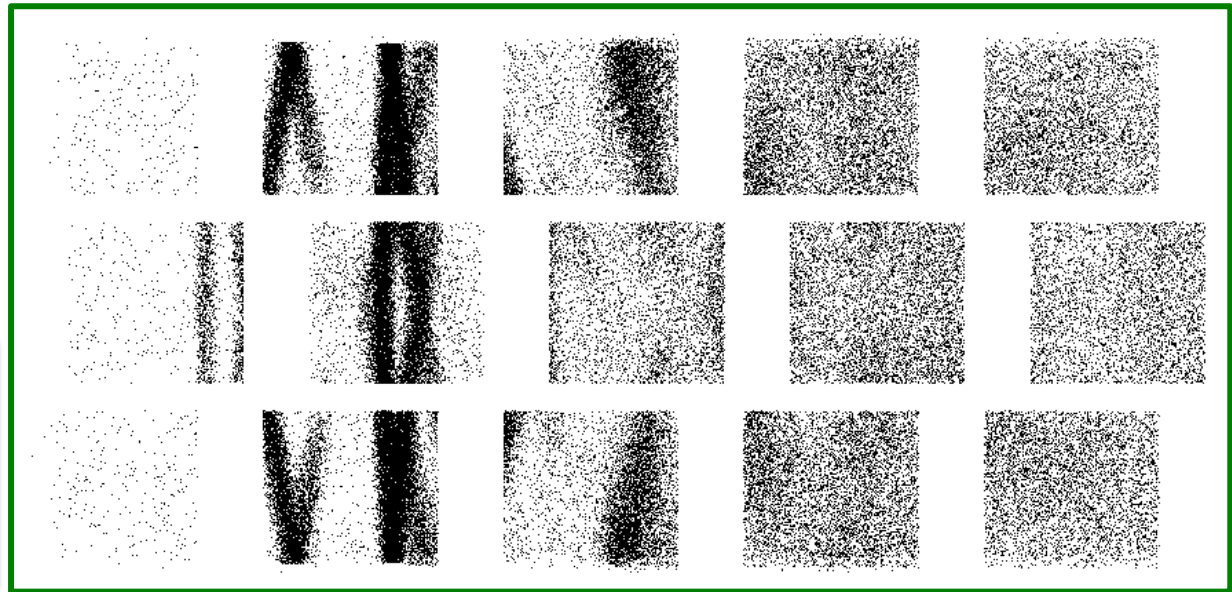
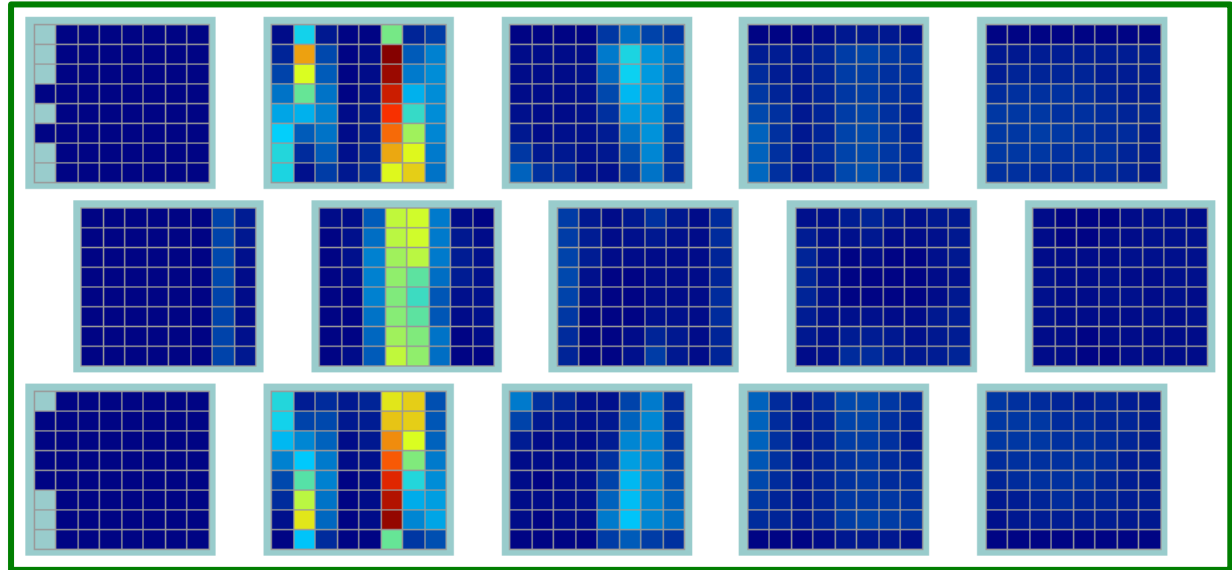
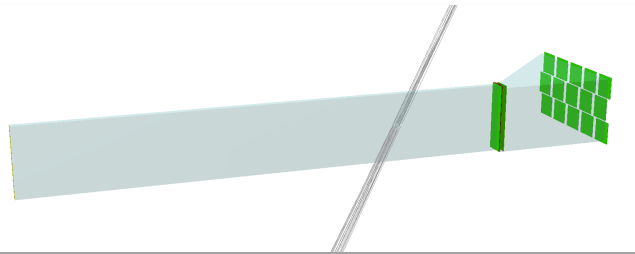

Wide Plate Data:

First glimpse on occupancies with raw cuts on timing and event multiplicity

Simulation predicts
~20 hits/track

No results yet, stay tuned.

Simulation:

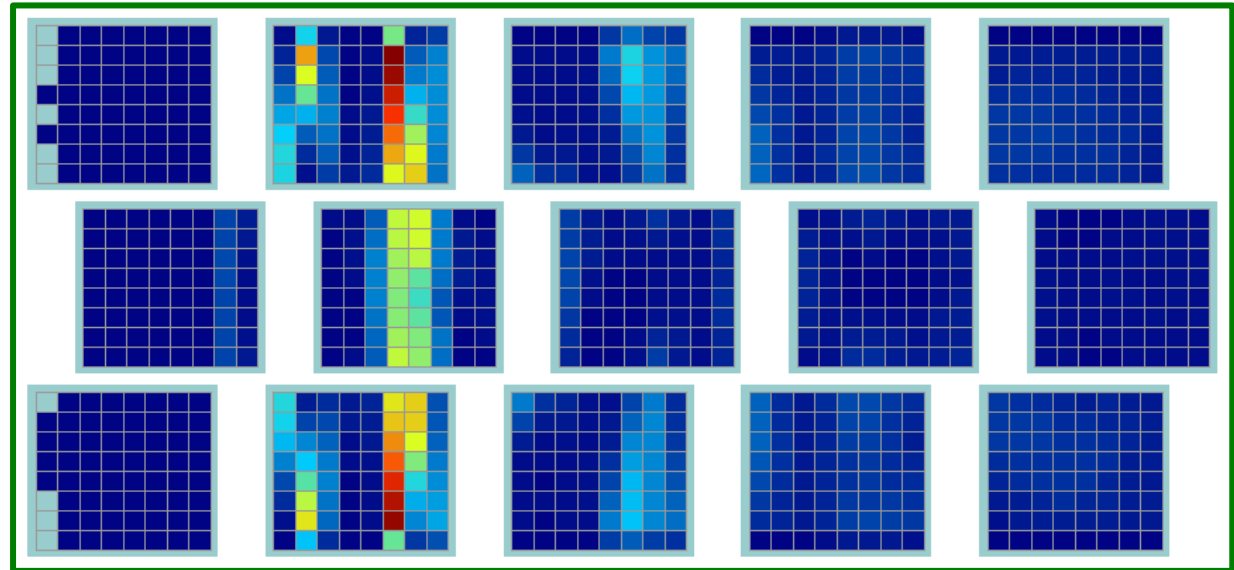

very preliminary

Beam data:

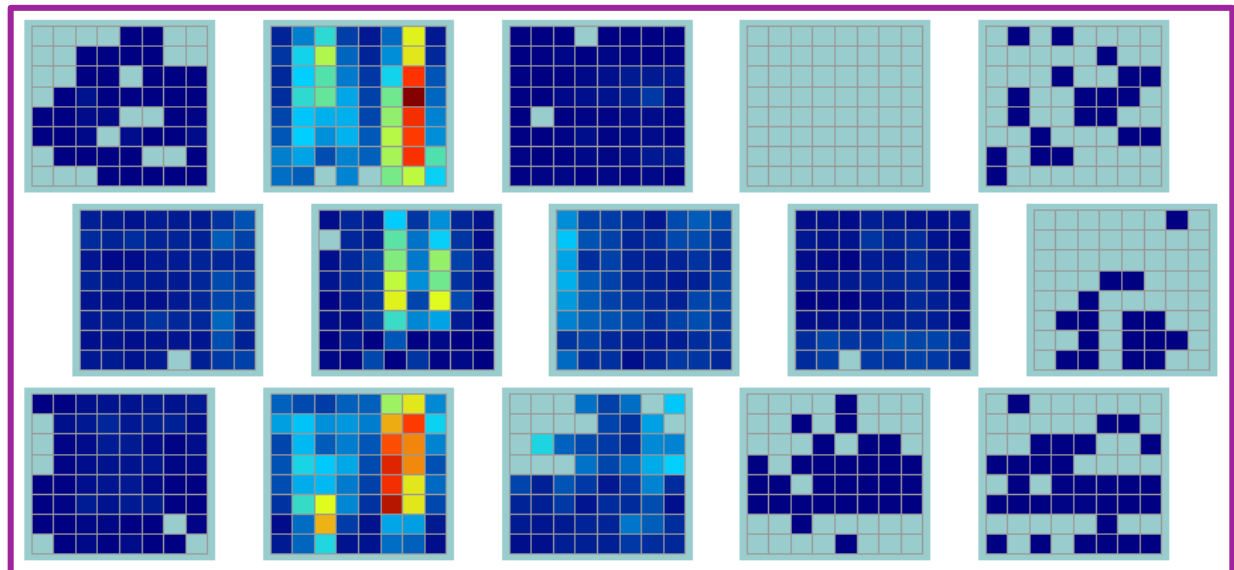
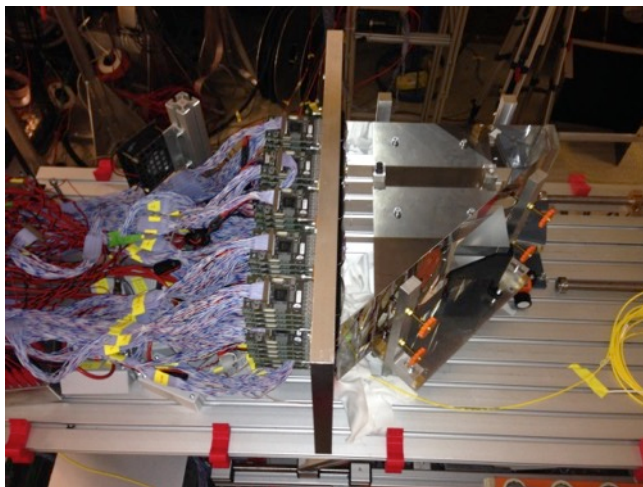

PANDA Endcap Disc DIRC, PID goal: 3σ π/K separation for $p < 4$ GeV/c.

First DIRC system for small angle forward PID. Four independent quarter segments.

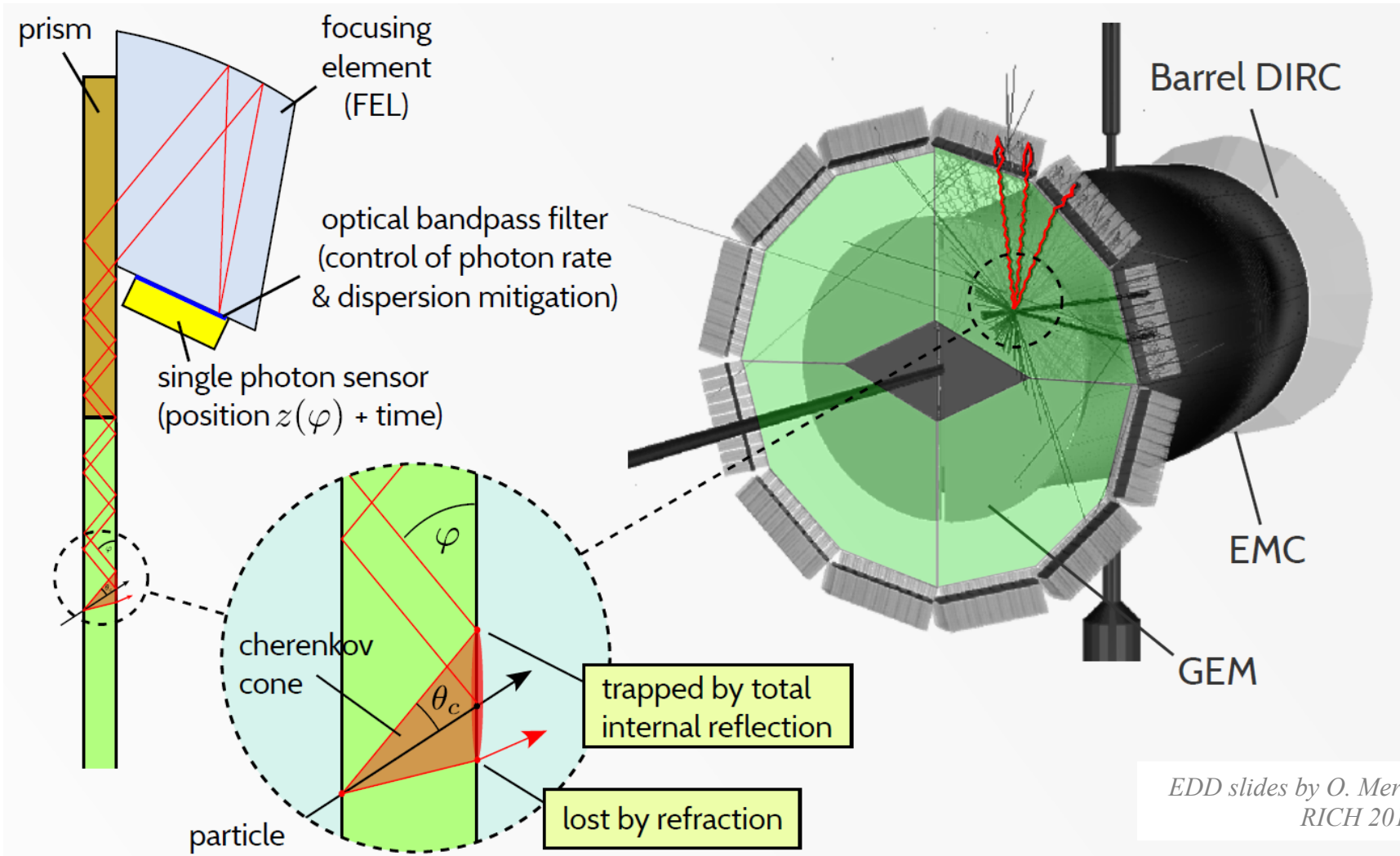

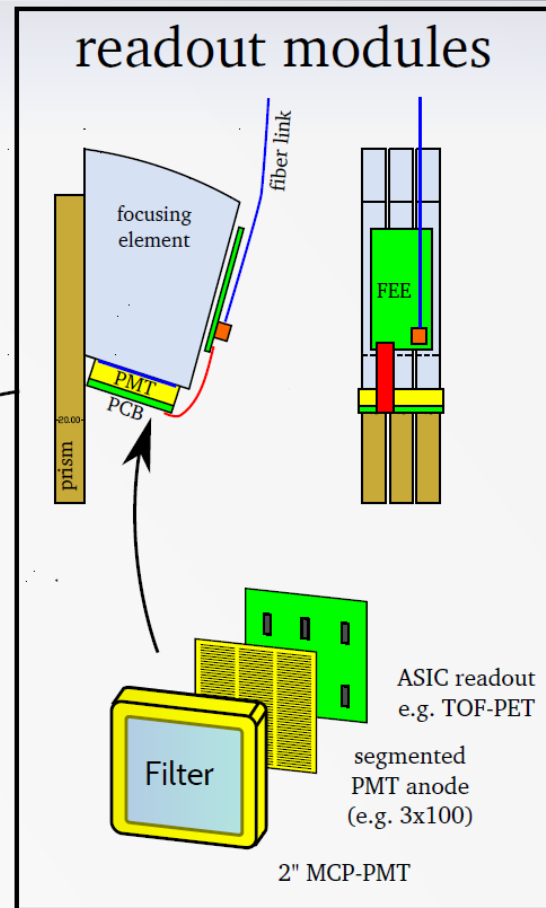
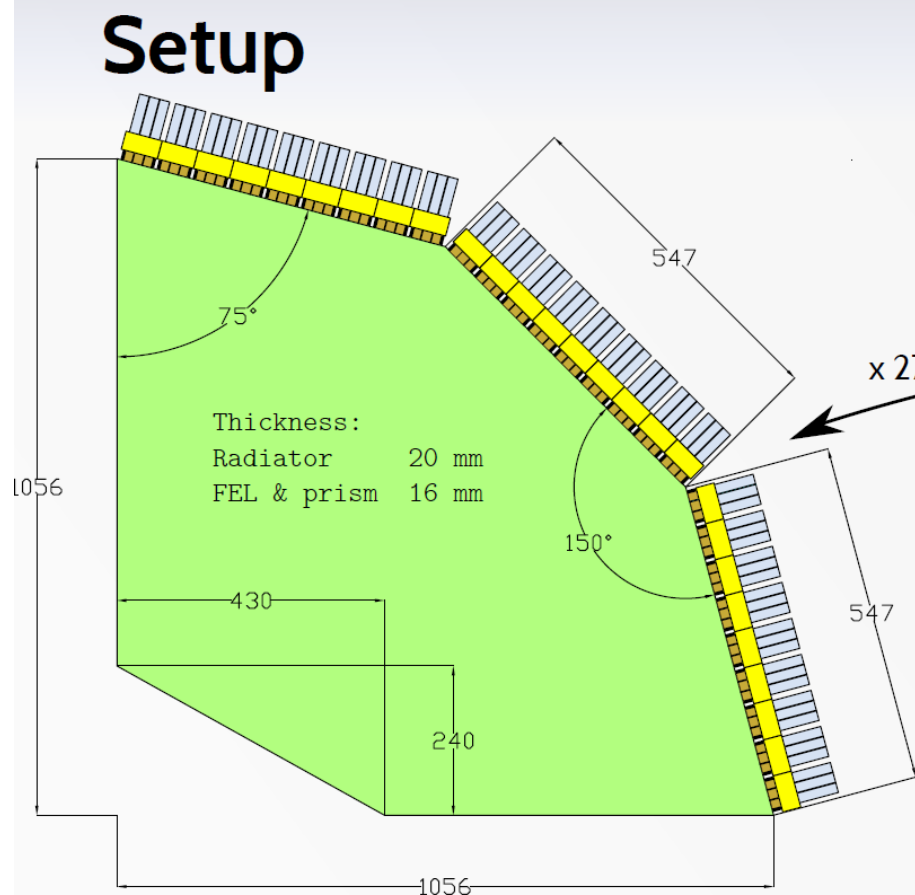

Filter band: 385 nm - 460 nm => $N_{ph} \approx 16$

Integrated anode charge: $Q \approx 5.6 \text{ C/cm}^2$
Avg. rate: 225 kHz/cm² (19 kHz/ch)
Peak data rate per module: ~0.6 GBit/s

ASIC candidate: TOF-PET (64 ch/die, 100 kHz/ch, ~6 mW/ch, 50 ps time-bin, 40 ns dead time)

Latest enhanced-lifetime MCP-PMT would be OK (with bandwidth filter to restrict rate)
but need fine segmentation in radius (0.5mm anode pitch) – similar to TORCH

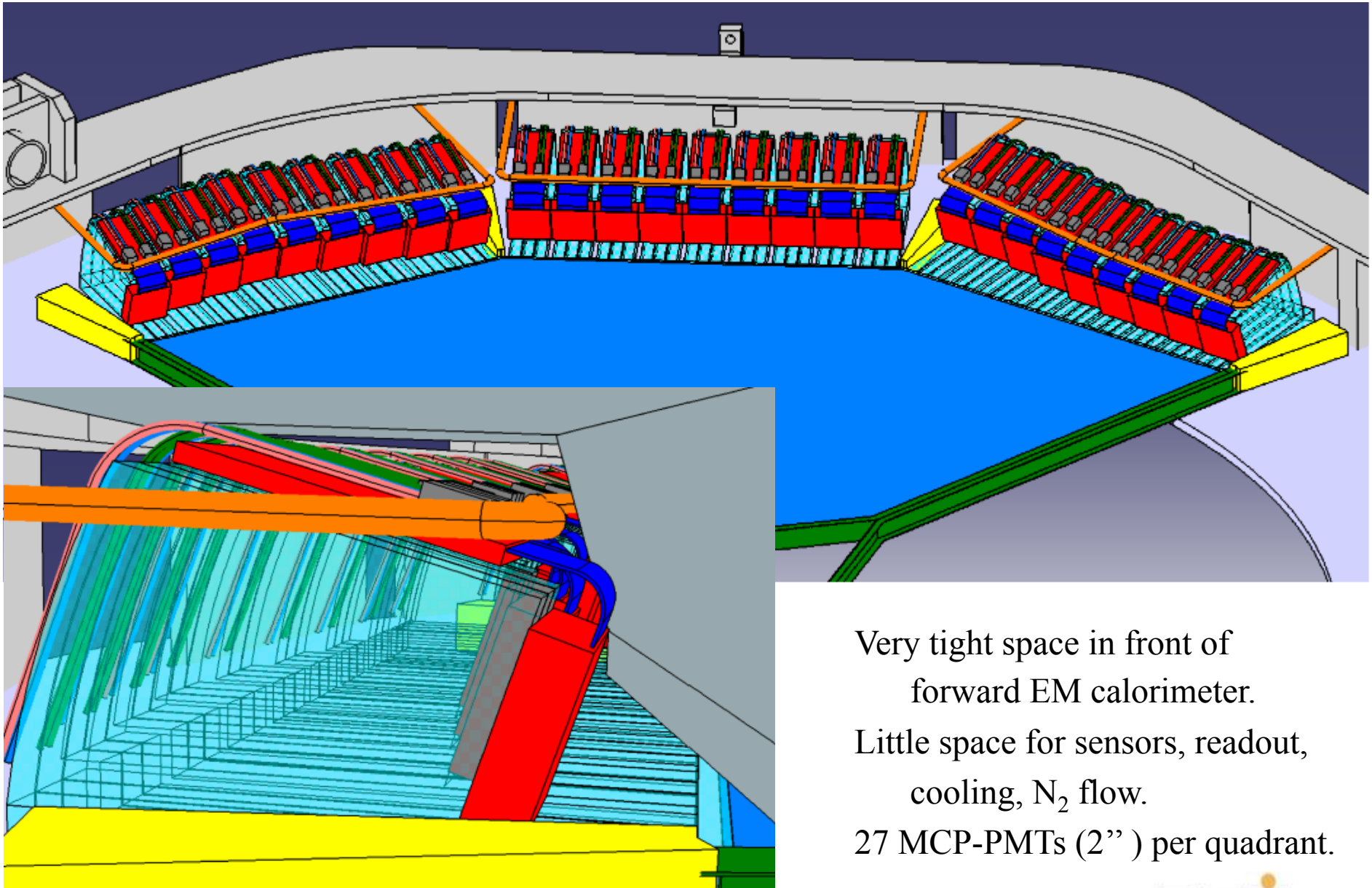

Very tight space in front of
forward EM calorimeter.
Little space for sensors, readout,
cooling, N₂ flow.
27 MCP-PMTs (2'') per quadrant.

π/K separation at 4 GeV/c for different number of FELs (SiO₂ prism)

2 x 10k tracks/marker, no exp. background
 1 mrad smearing of particle track in θ and φ
 0.5 mm pixel size, passband: 385 - 460 nm

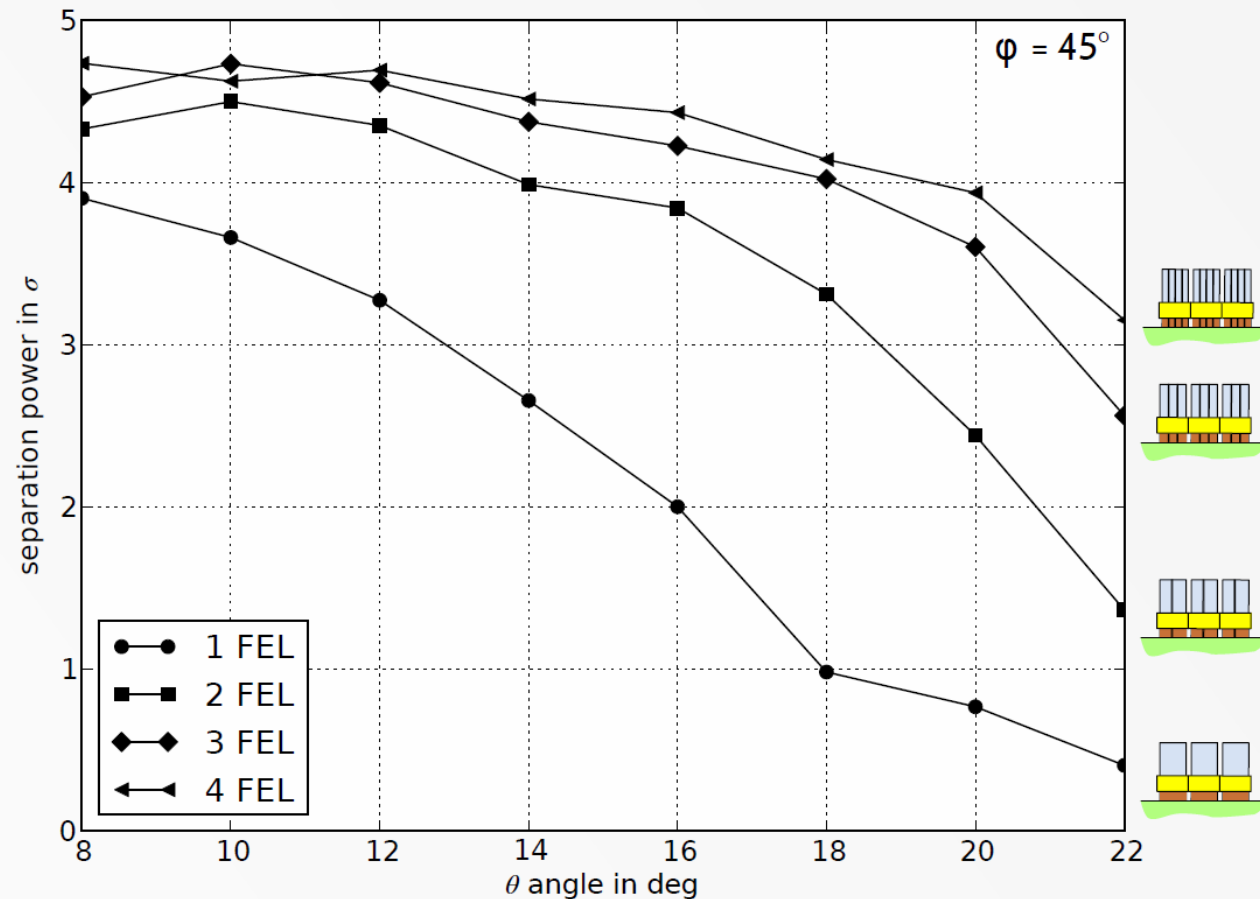

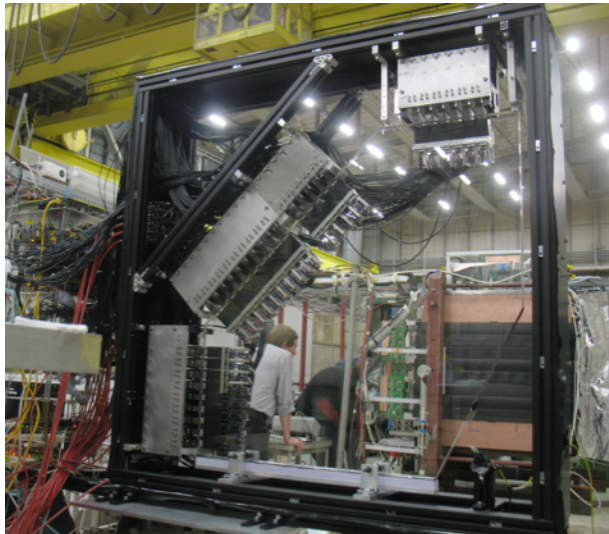

Quarter-disk prototype in testbeam
at CERN and DESY

Track-by-track PID demonstrated.

*Low-cost R&D prototype:
borosilicate disk,
PMMA lightguides,
limited number of channels.*

Results

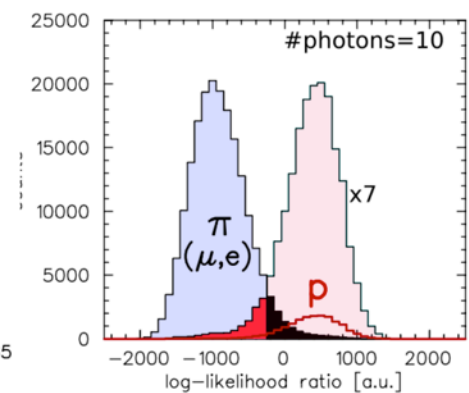
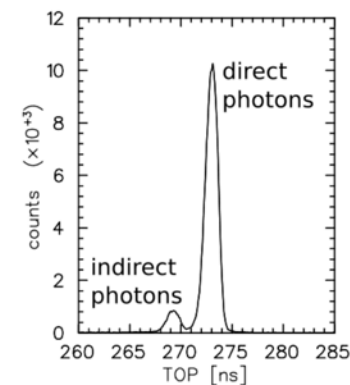
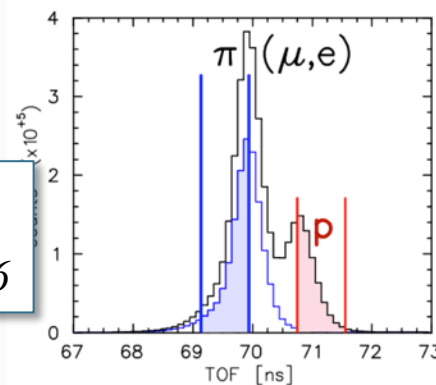
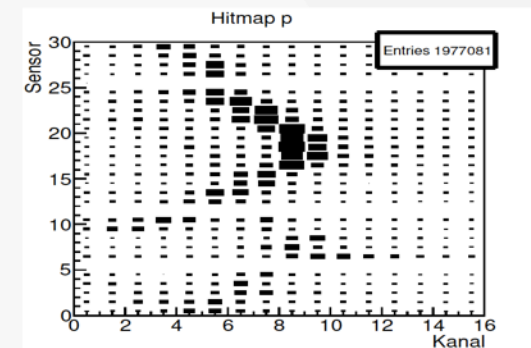
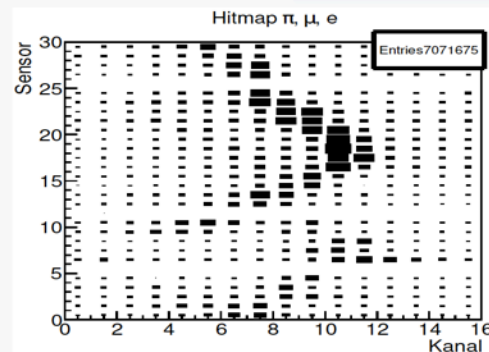

*Next step: validate design with
high-resolution prototype in 2015/6*

Search for the right MCP-PMT:

New prototype MCP-PMT with fine anode pitch

PHOTONIS XP85132-Q-MD2

3 x 100 anode layout

59mm x 59mm size, 50mm x 50mm active area

Pedestal window (small P.C.-MCP gap)

View of anode strips

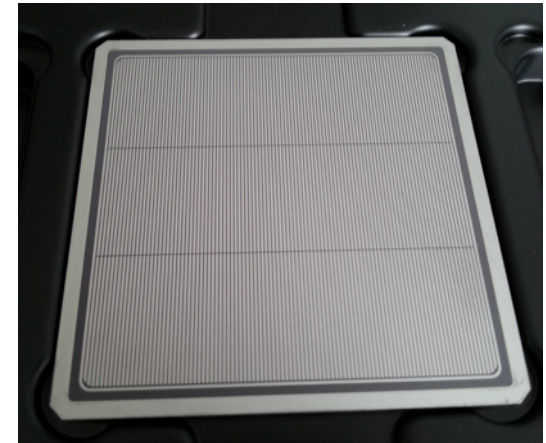

Front view in holder

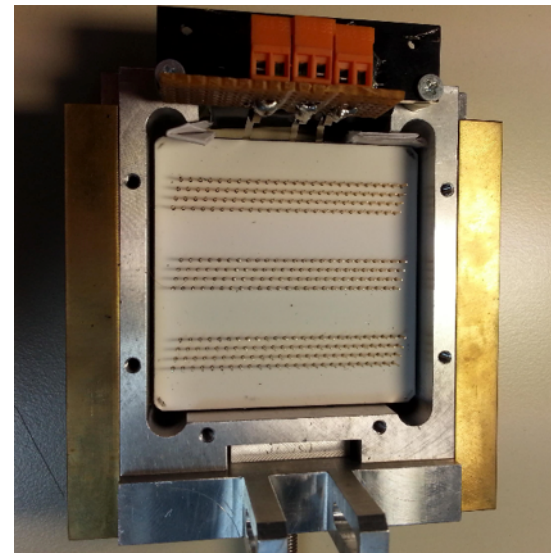
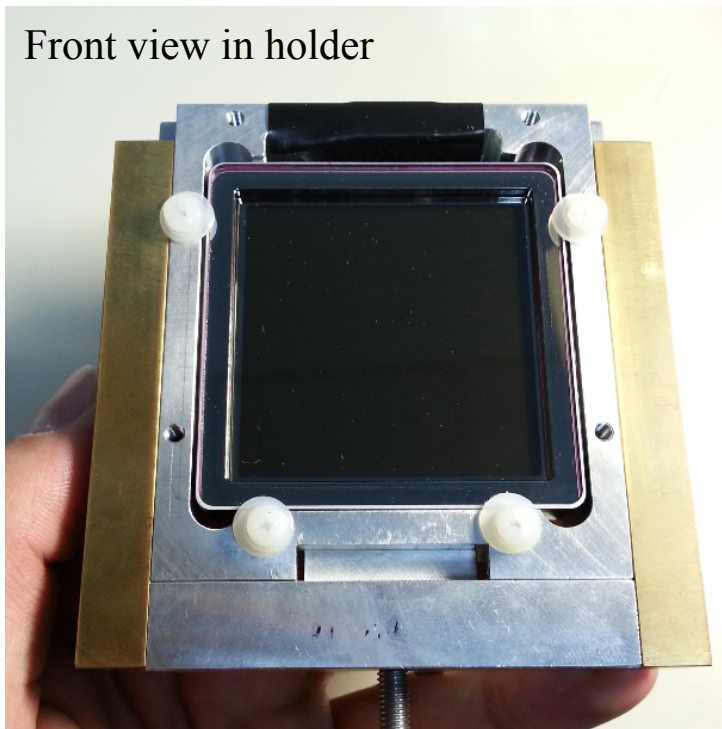

Rear view (anode pin array) in holder

J. Rieke, IEEE 2014

Some initial and very preliminary tests of the new 3 x 100 Planacon (Giessen group)

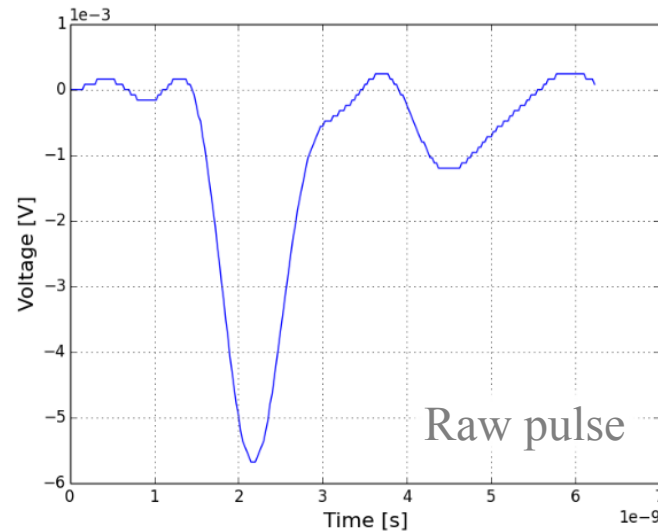

PHOTONIS XP85132-Q-MD2

J. Rieke, IEEE 2014

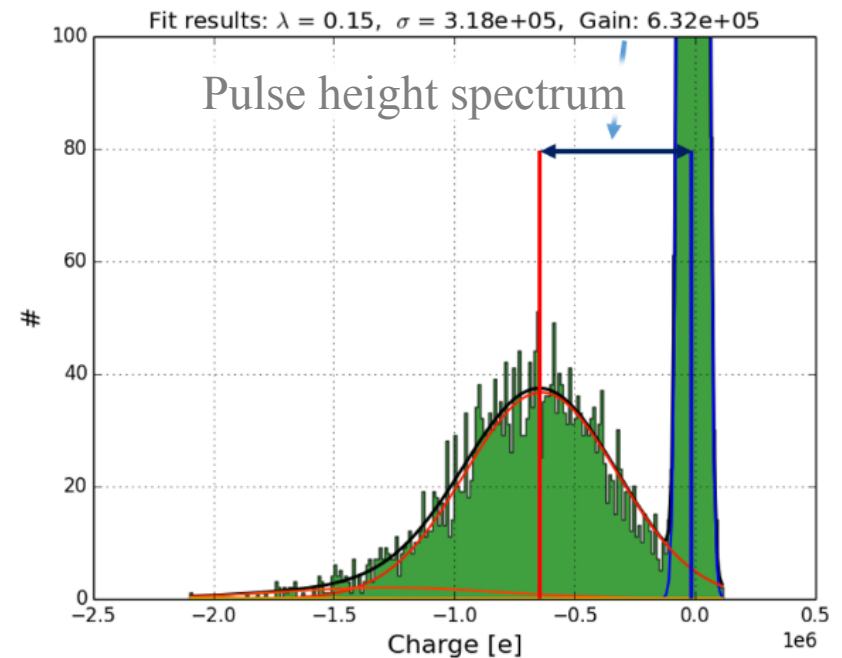
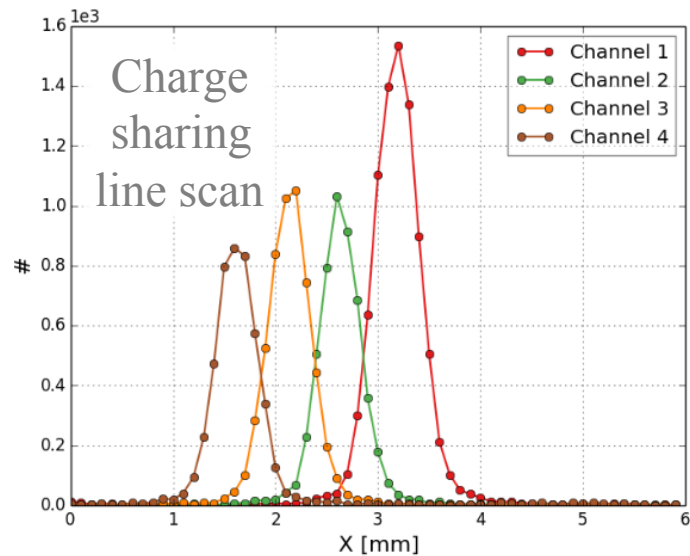

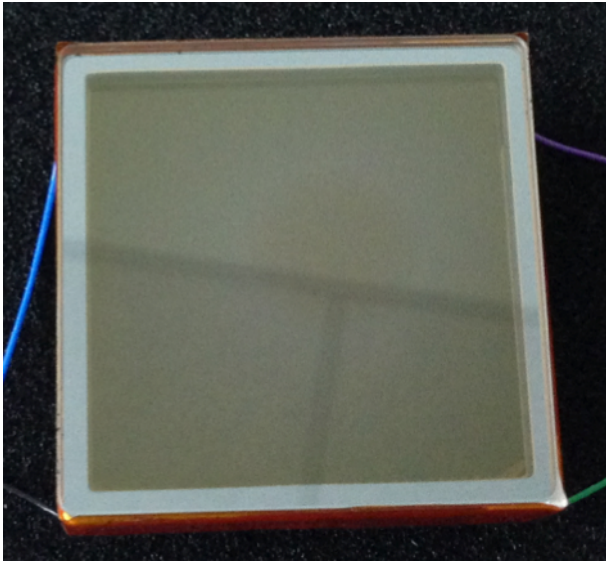

Just received:

New prototype [Hamamatsu](#) MCP-PMT with fine anode pitch

6 x 128 anode layout

60mm x 60mm size, 53mm x 53mm active area

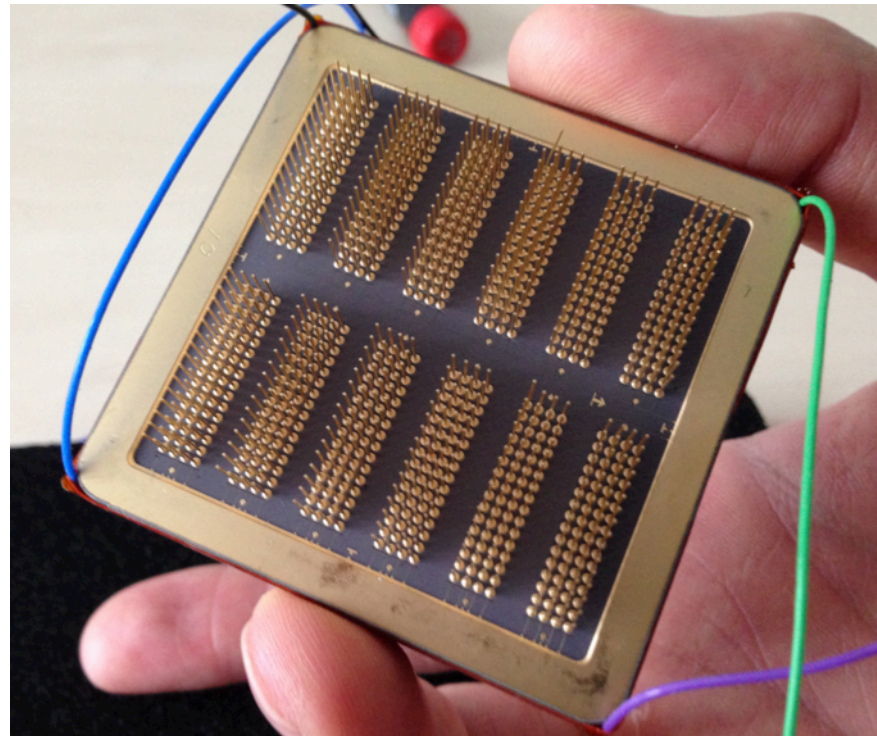

J. Rieke, IEEE 2014

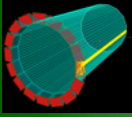

DIRC-based PID for the EIC

— Progress Report and Renewal Proposal

T. Cao¹, R. Dzhygadlo², T. Horn³, C. Hyde⁴, Y. Ilieva¹, G. Kalicy⁴,
P. Nadel-Turonski^{5,*}, K. Park⁴, K. Peters², C. Schwarz², J. Schwiening²,
W. Xi⁵, N. Zachariou¹, C. Zorn⁵.

- 1) University of South Carolina, Columbia, SC 29208
- 2) GSI Helmholtzzentrum für Schwerionenforschung GmbH, 64291 Darmstadt, Germany
- 3) The Catholic University of America, Washington, DC 20064
- 4) Old Dominion University, Norfolk, VA 23529
- 5) Jefferson Lab, Newport News, VA 23606

Generic Detector R&D for an Electron Ion Collider.

DOE Funding since 2011.

Thanks for the material provided for this talk.

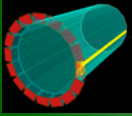

DIRC@EIC R&D GOAL

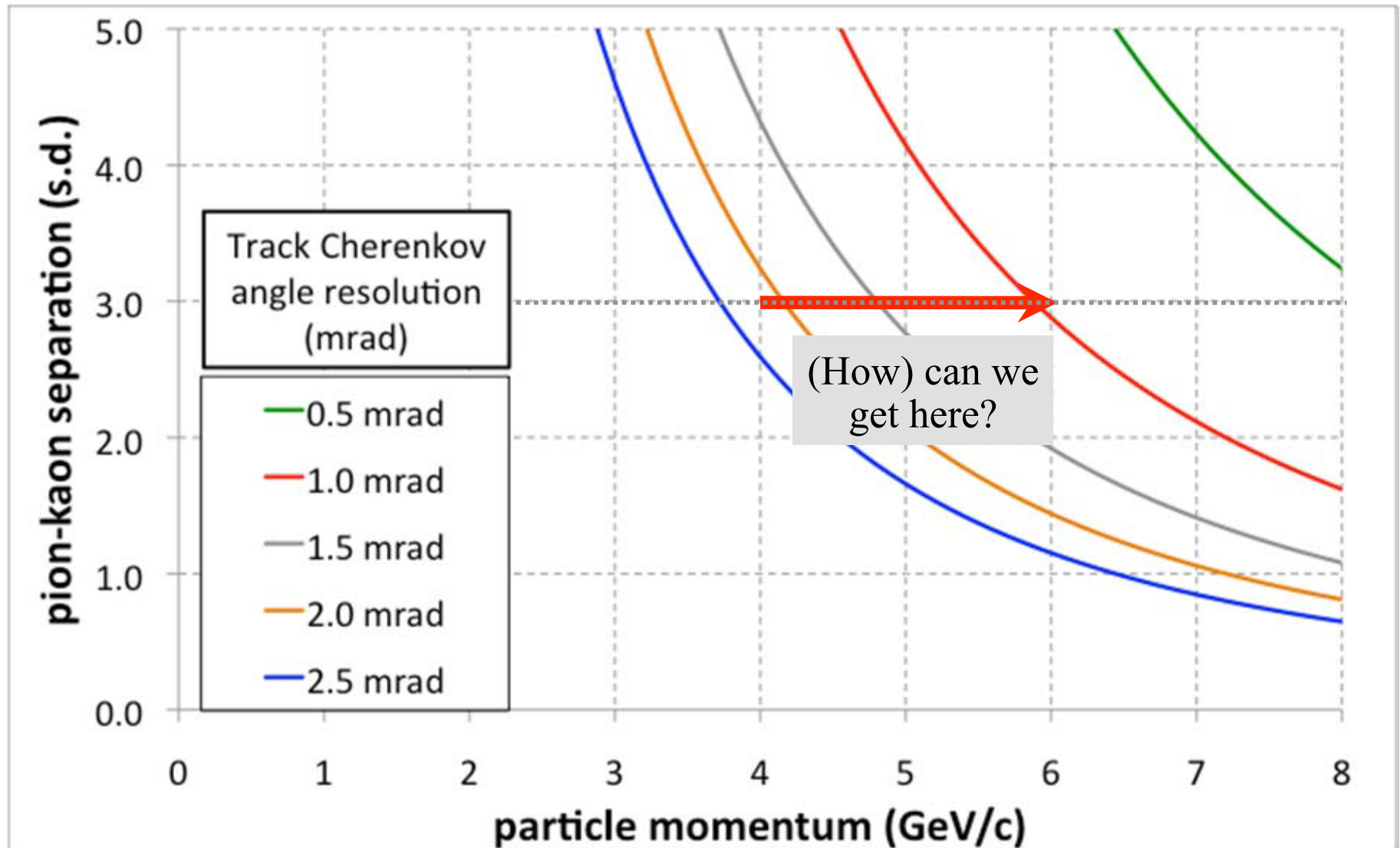

- Proof-of-concept simulations suggest possible to reach 6 GeV/c at forward angles

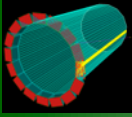

1. Investigate possibility of pushing state-of-the-art performance

- Extend 3σ π/K separation beyond 4 GeV/c, maybe as high as 6 GeV/c
 - also improves e/π and K/p separation

2. Demonstrate feasibility of using a DIRC in the EIC detector

- Compact readout “camera” (focusing + expansion volume (EV) + sensors)
 - simulations, lens and EV design, prototyping, test beams
- Operation in high magnetic fields (up to 3 T)
 - sensor tests up to 5T

Our current R&D focus.

3. Study integration of the DIRC with other detector systems

- Supplementary Cherenkov? Internal or external readout? Bars or plates?
- Impact on endcap design and barrel calorimeter? New configurations?

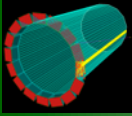

DIRC@EIC R&D ROADMAP

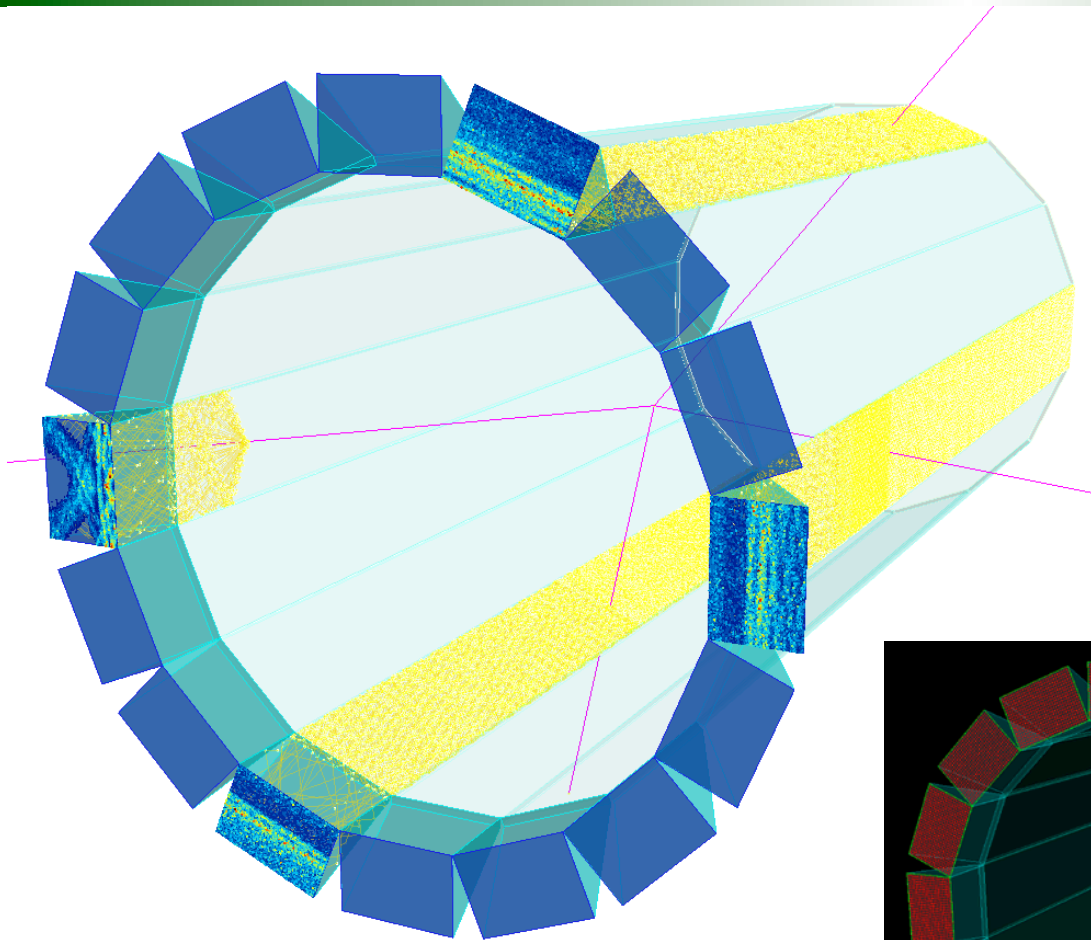

Geant4

Wide plate geometry

Size of EV/prism readout end:

256mm x 390mm

Simulation w/o B field: straight tracks, symmetric patterns.

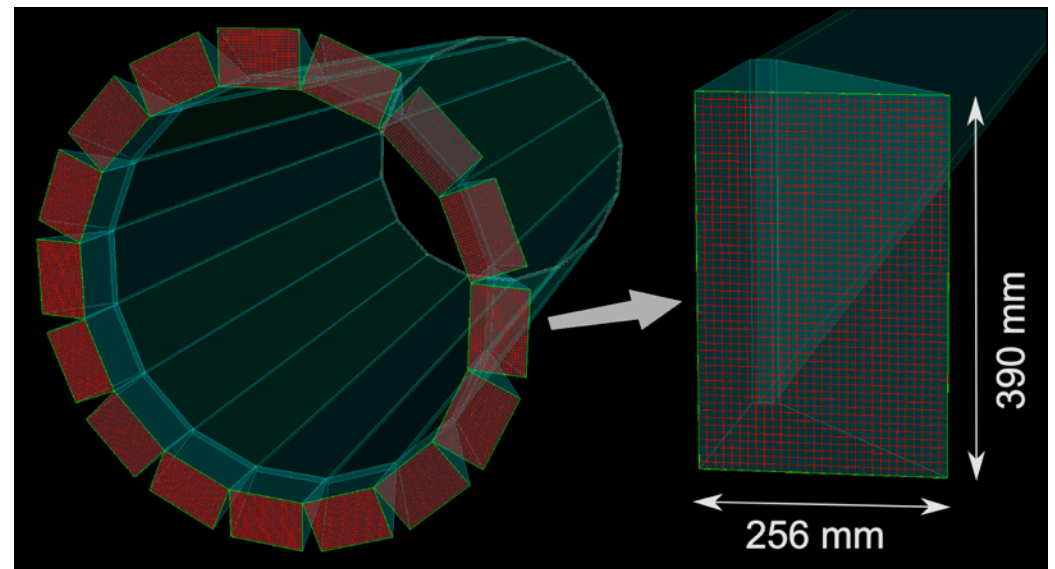

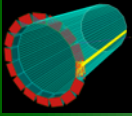

DIRC@EIC R&D ROADMAP

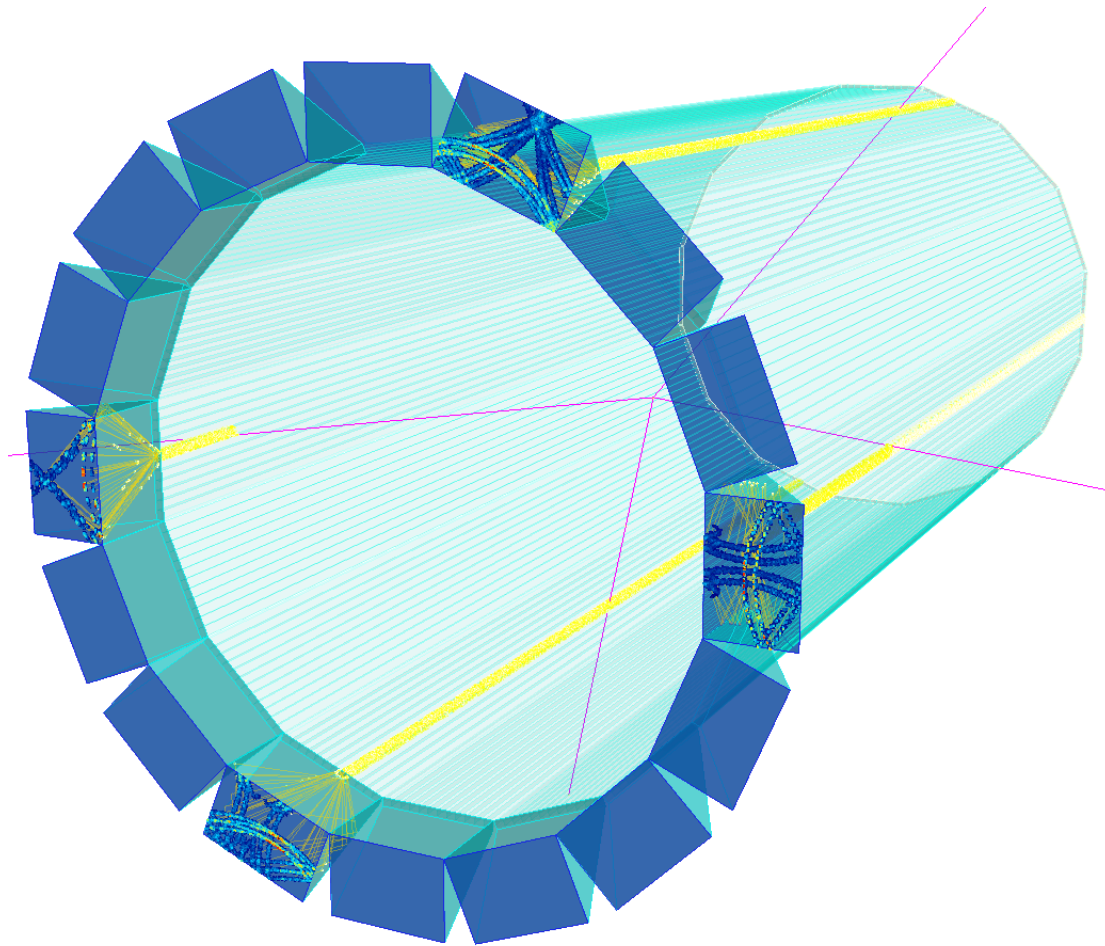

Geant4
Narrow bar geometry
Spherical lens w/o air gap.
(Remember: synergy with
PANDA Barrel DIRC R&D)

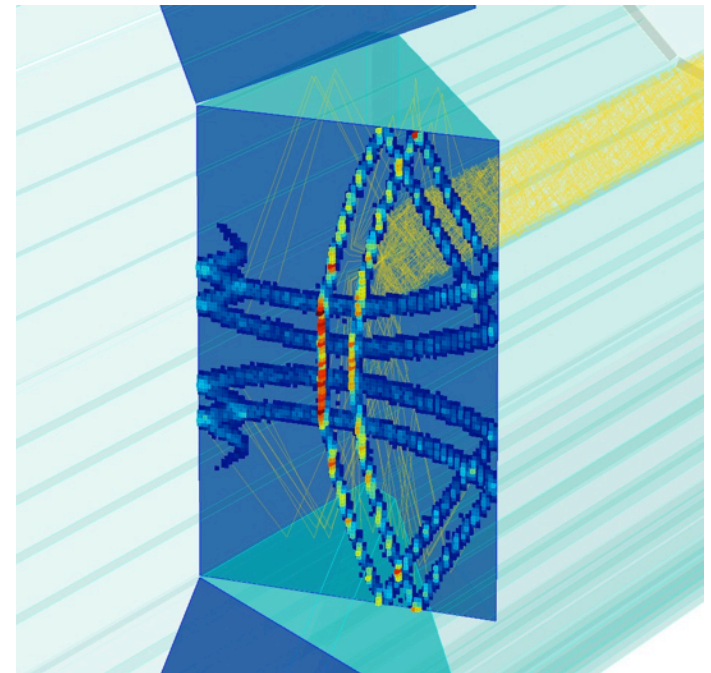

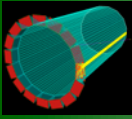

Possible layouts with internal and external EV

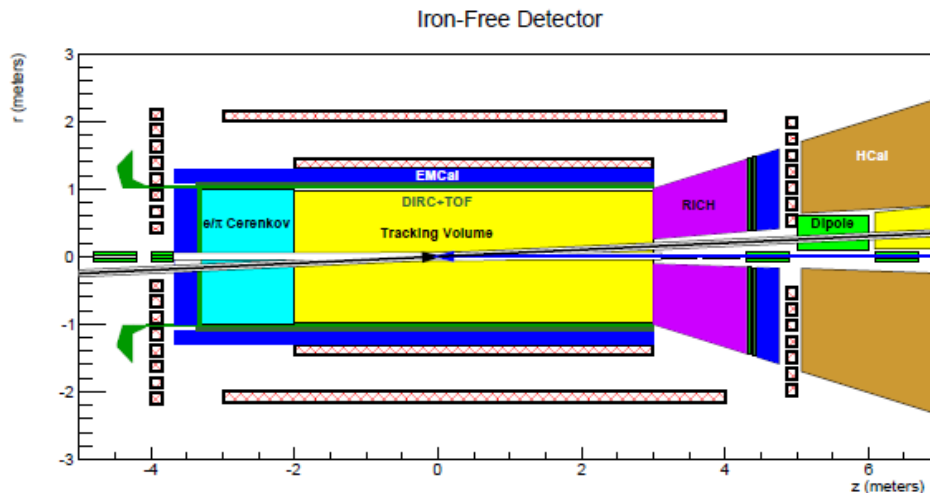
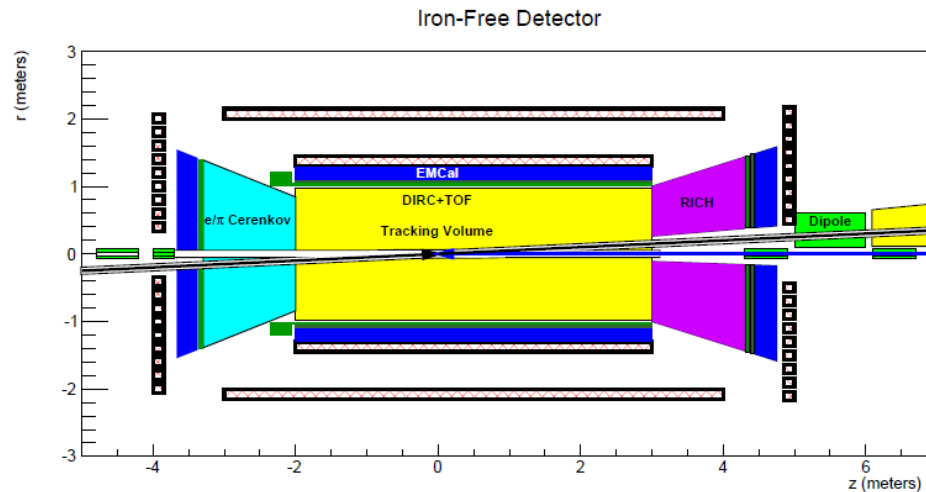

- A DIRC-based PID solution for the central detector can have the EV placed inside or outside of the detector.
- An internal solution requires a compact EV
- The DIRC bars/plates would be quite long if the EV was outside.
- Need to evaluate the impact of long bars/plates on endcap design
- Caveat: flux return using endcap coil walls instead of iron could offer variations on the theme

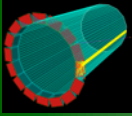

Possible layouts with internal and external EV

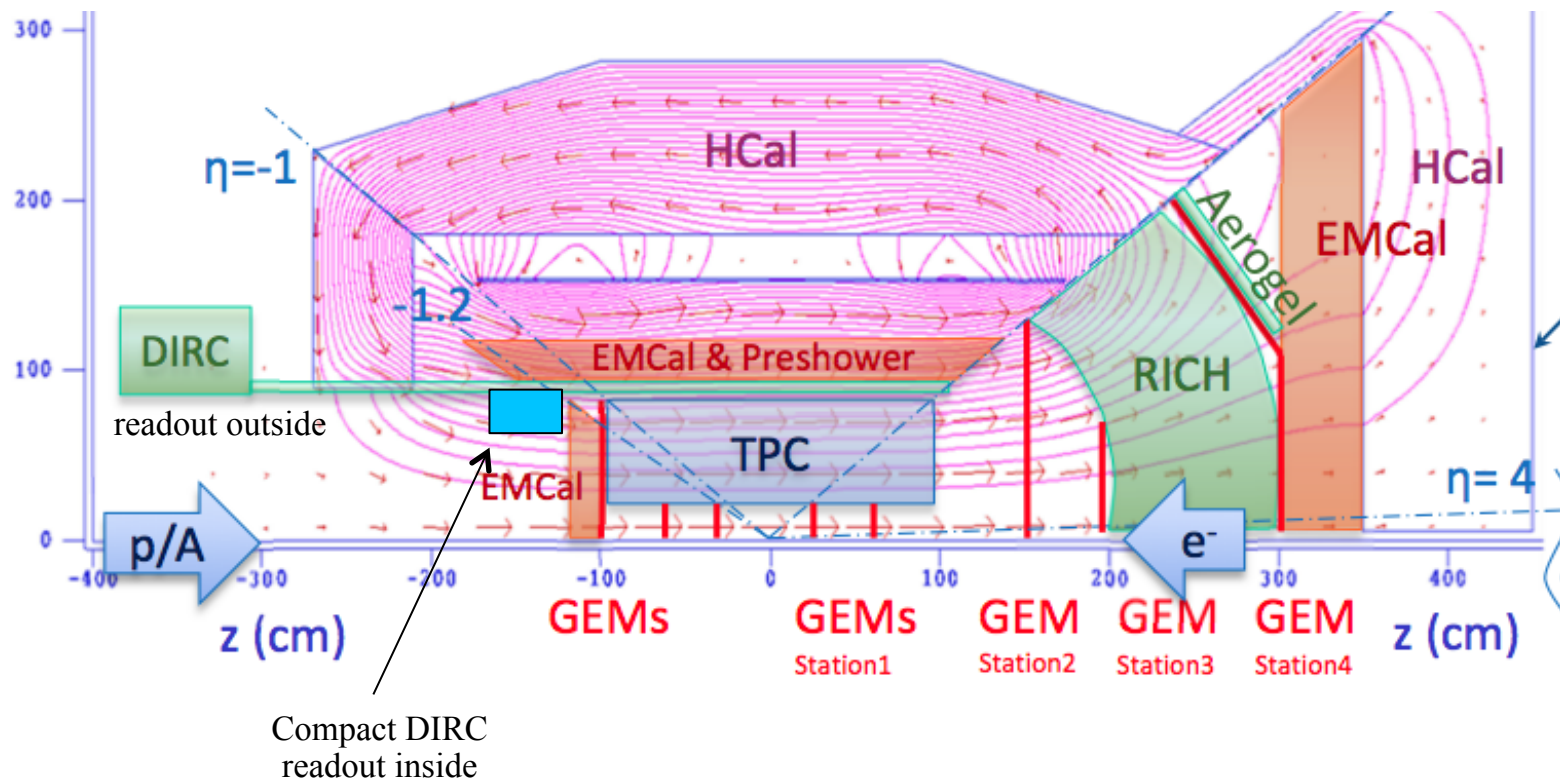

- An EIC detector evolved from a new PHENIX, based on the BABAR solenoid, would provide a lot of semi-internal space for the DIRC readout



DIRC R&D DIRECTIONS



$$\sigma_{\theta_c}^{track} = \frac{\sigma_{\theta_c}^{photon}}{\sqrt{N_{p.e.}}} \otimes \sigma^{correlated}$$

Correlated term:
tracking detectors, multiple scattering, etc

$$\sigma_{\theta_c}^{photon} = \sqrt{\sigma_{bar-size}^2 + \sigma_{pixel-size}^2 + \sigma_{chromatic}^2 + \sigma_{bar-imperfection}^2}$$

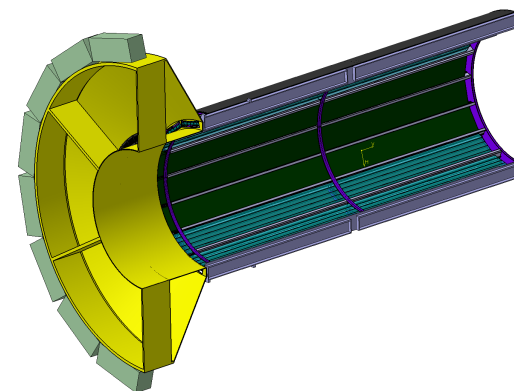

To repeat success of the BABAR DIRC with smaller expansion volume or to improve DIRC performance:

Minimize single photon Cherenkov angle resolution and/or maximize photon yield.

Barrel DIRCs: improve focusing using complex multi-component lens systems, fast timing to mitigate chromatic dispersion and as equally important 3rd dimension in reconstruction.

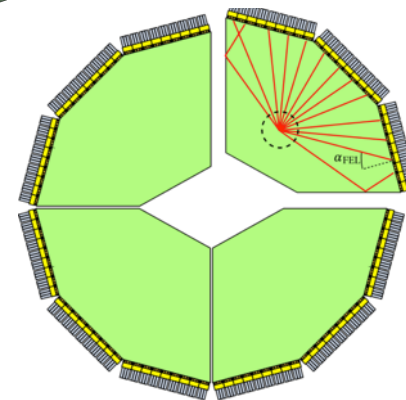

Disc DIRC: pioneered focusing light guides, now looking for MCP-PMTs with finely segmented anodes (like TORCH).

New MCP-PMTs are clearly the preferred sensors; what properties matter most to future DIRCs?

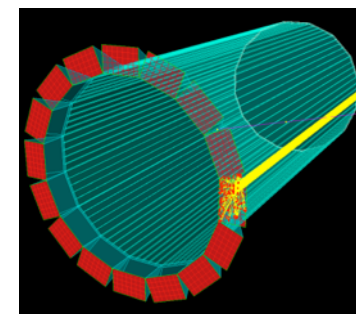

PANDA DIRCs require compact, fast multi-pixel sensor with single photon sensitivity in strong magnetic field with trigger-less DAQ and 20MHz average interaction rate.

- Good geometrical resolution over a large surface
 - multi-pixel sensors** with $\sim 5 \times 5$ mm anodes for Barrel DIRC, ~ 0.5 mm anode pitch in radial direction for Disc DIRC.
- Single photon detection inside B-field
 - high gain** ($> 5 \times 10^5$) at 1-2 Tesla
- Time resolution for photon time of propagation and/or dispersion correction
 - very good time resolution** of < 100 ps for single photons
- Few photons per track
 - high detection efficiency** $PDE = QE * CE * GE$
 - low dark count rate**
- Photon rates in the MHz regime
 - high rate capability** with rates up to MHz/cm²
 - long lifetime** with integrated anode charge of 0.5 to 2 C/cm²/y
 - multi-hit capability** with 10-15 photons per 60x60mm unit

Hamamatsu 6x128 PHOTONIS 3x100

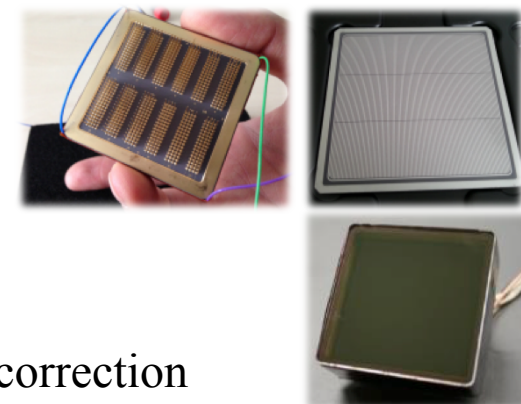

PHOTONIS 8x8

PANDA Barrel DIRC Prototype

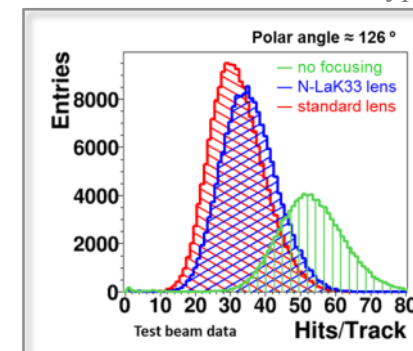



DIRC SENSOR CANDIDATES



- **Multi-anode Photomultipliers (MaPMTs)**

used successfully in DIRC prototypes,
was sensor of choice for SuperB FDIRC
ruled out by 1T magnetic field

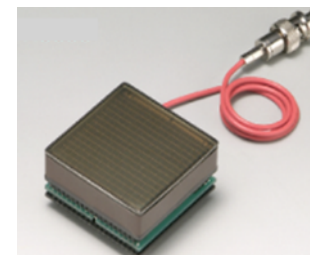

- **Geiger-mode Avalanche Photo Diodes (SiPMs)**

high dark count rate problematic for reconstruction (trigger-less DAQ)
radiation hardness an issue in PANDA environment

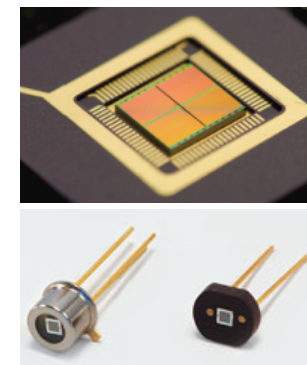

- **Micro-channel Plate Photomultipliers (MCP-PMTs)**

good PDE, excellent timing and magnetic field performance
issues with rate capability and aging

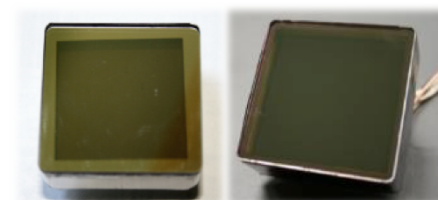



MCP-PMT PERFORMANCE EXAMPLES

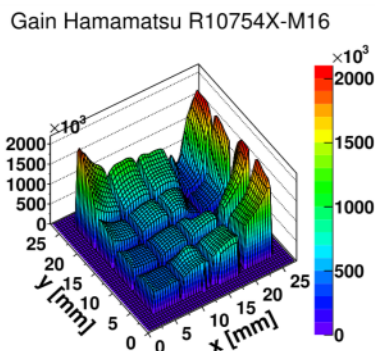
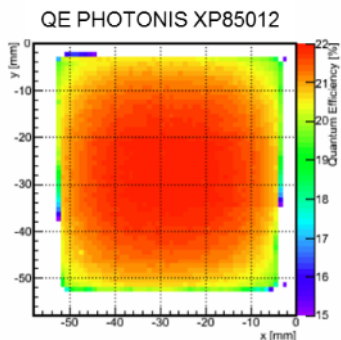
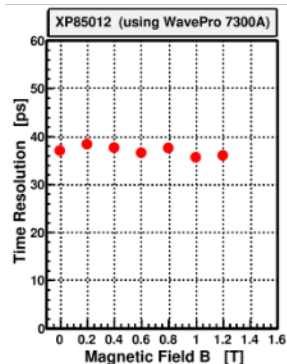
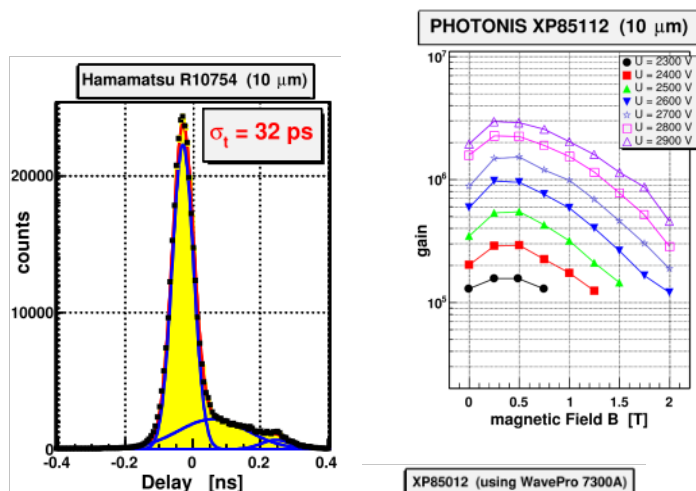

Detailed study of MCP-PMT performance:

- prototypes from BINP, PHOTONIS, Hamamatsu
- single photon time resolution
- gain and quantum efficiency scans
- charge sharing/cross-talk
- rate capability
- tests with and without magnetic field

MCP-PMTs meet *most* PANDA DIRC goals.

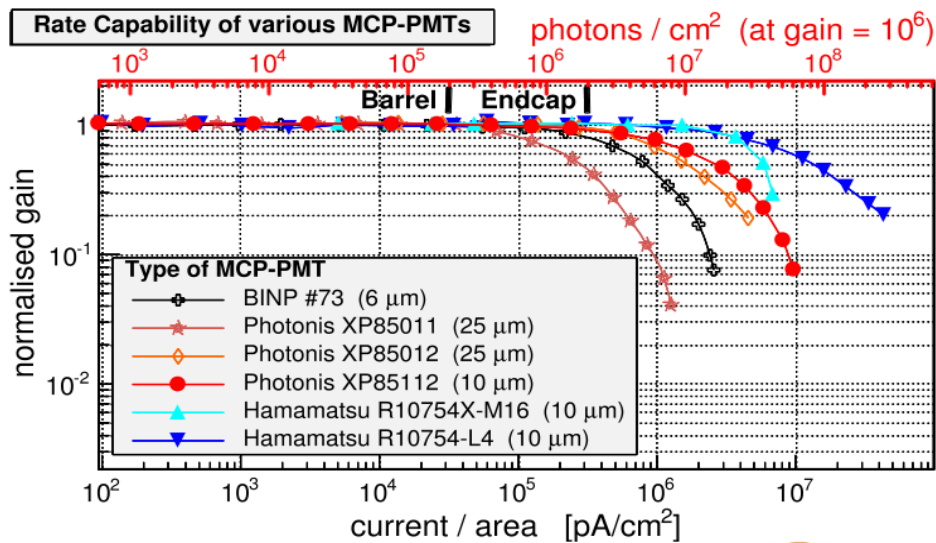

All results from Erlangen group.
For a more complete review:
A. Lehmann's talks at
RICH 2013 and at LIGHT14



MCP-PMT LIFETIME IN 2011



The main issue with using MCP-PMTs for PANDA DIRCs:
aging of photocathode

Status of our MCP-PMT lifetime measurements in 2011

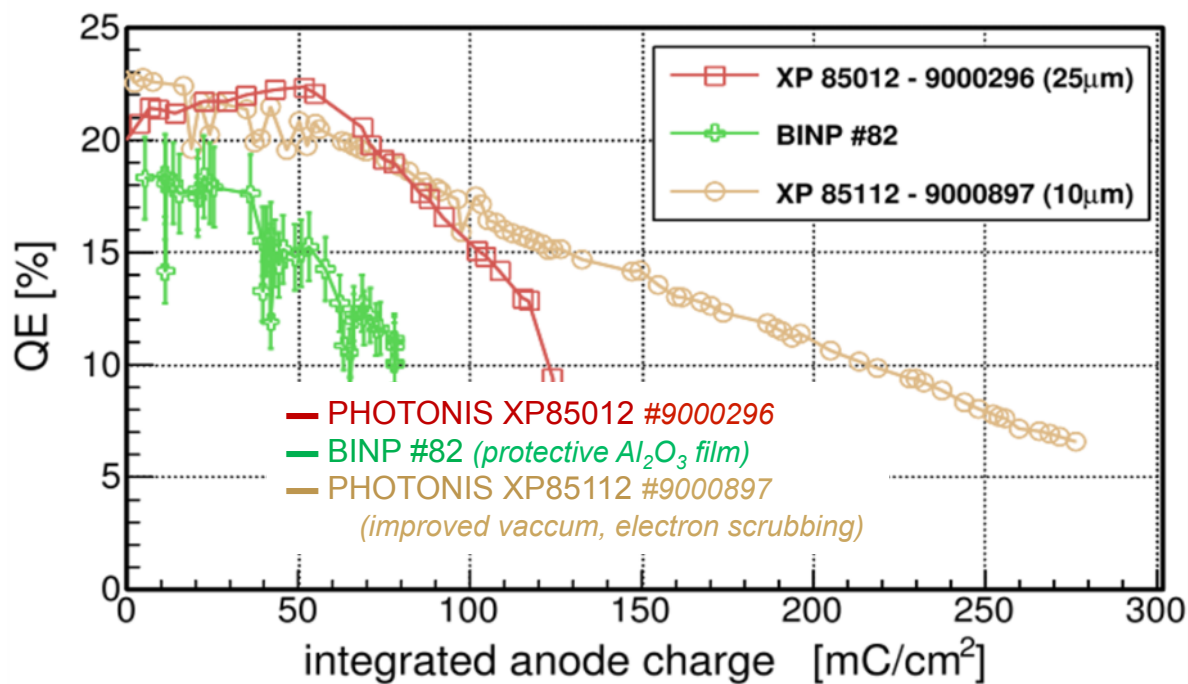

Quantum efficiency reduced by 50% or more at only <200 mC/cm²

But: PANDA DIRCs require lifetime of 5-10 C/cm²



MCP-PMT LIFETIME IN 2011



The main issue with using MCP-PMTs for PANDA DIRCs:
aging of photocathode

Status of our MCP-PMT lifetime measurements in 2011

PANDA Barrel DIRC time [years]

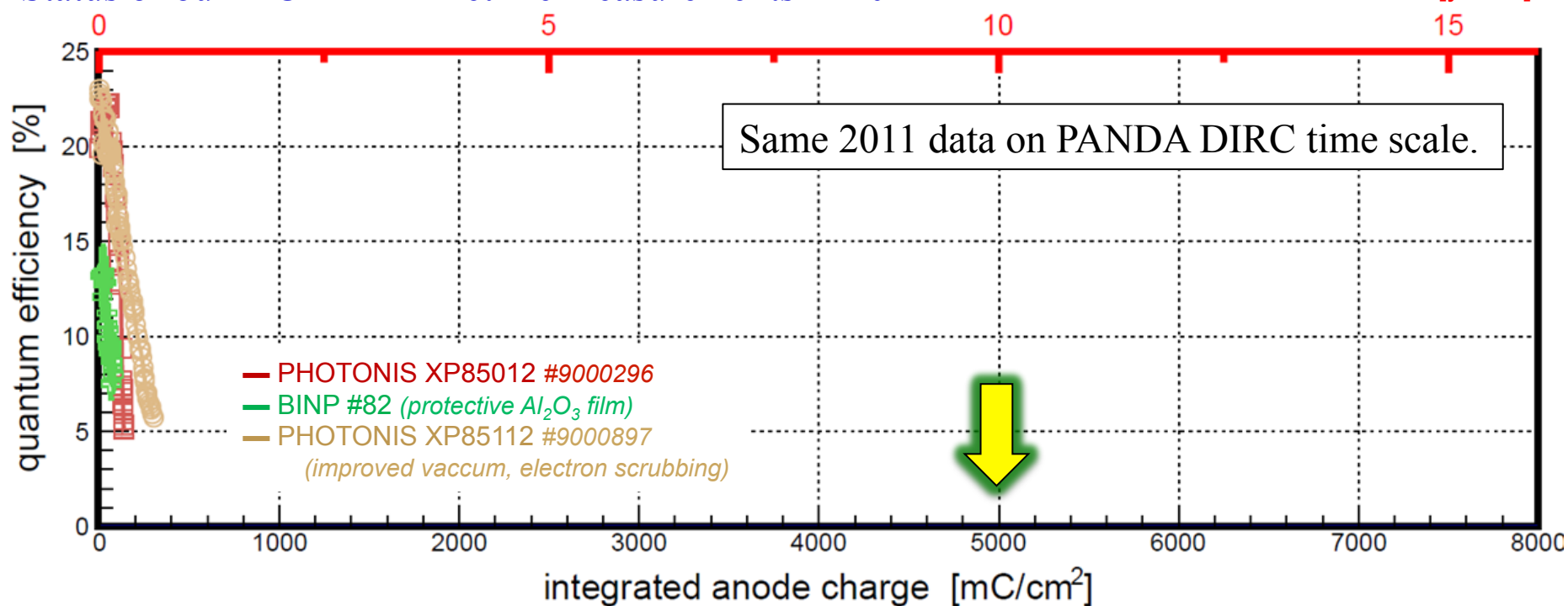

None of the MCP-PMTs in 2011 would have survived for more than 2 months in PANDA.
→ needed factor ~50 (“breakthrough”) improvement in MCP-PMT lifetime



MCP-PMT AGING MEASUREMENTS



Simultaneously age all MCP-PMTs **at rates comparable to PANDA DIRC environment**

- common systematics, results easy to compare and interpret
- continuous illumination (460nm LED, 0.25-1MHz rate, single photon level)
- permanent monitoring (MCP pulse heights, LED intensity)
- frequent QE measurements (250-700nm, monochromator)
- setup in operation for more than three years

started with standard MCP-PMTs

lifetime-improved MCP-PMTs ~3 years ago

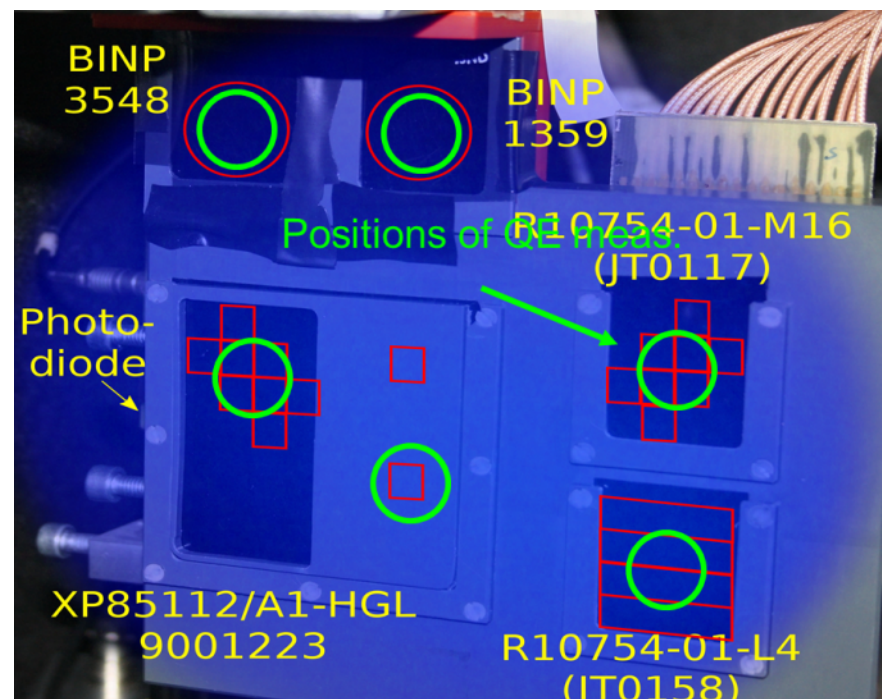
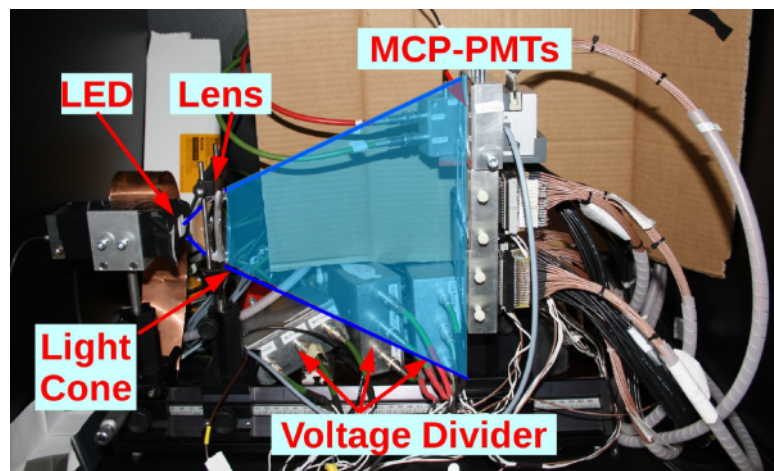



MCP-PMT AGING MEASUREMENTS

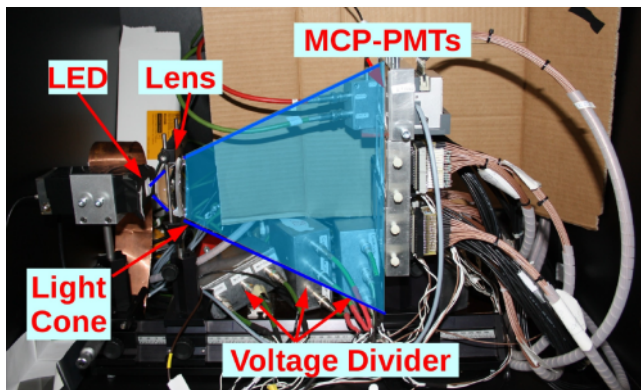

Summary of MCP-PMTs measured in setup

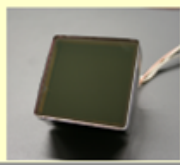

	BINP		PHOTONIS			Hamamatsu	
			XP85012	XP85112	XP85112	R10754X-01-M16	R10754X-07-M16M
pore size (μm)	6	7	25	10	10	10	10
number of pixels	1	1	8x8	8x8	8x8	4x4	4x4
active area (mm^2)	$9^2 \pi$	$9^2 \pi$	53x53	53x53	53x53	22x22	22x22
total area (mm^2)	$15.5^2 \pi$	$15.5^2 \pi$	59x59	59x59	59x59	27.5x27.5	27.5x27.5
geom. efficiency (%)	36	36	81	81	81	61	61
photo cathode	multi-alkali		bi-alkali			multi-alkali	
peak Q.E.	21% @ 495 nm	21% @ 495 nm	20% @ 380 nm	23% @ 380 nm	22% @ 380 nm	21% @ 375 nm	22% @ 415 nm
comments	better vacuum, new cathode		better vacuum, polished surfaces	better vacuum, polished surfaces	better vacuum, ALD surfaces	protection layer between MCPs	further improved lifetime (ALD)
# of tubes measured	1	2	1	1	3	1 (+1 L4)	2
							



MCP-PMT AGING MEASUREMENTS

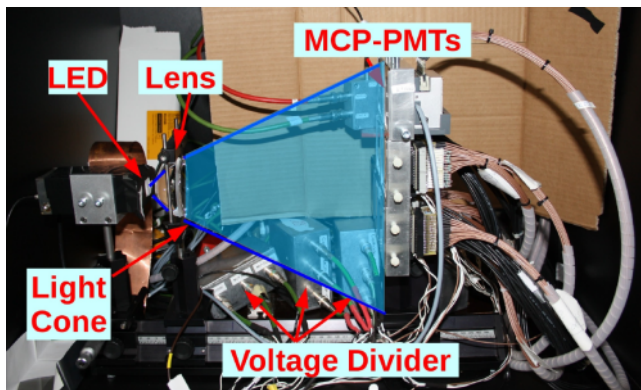

Summary of MCP-PMTs measured in setup



	Sensor ID	Integrated charge (as of Oct. 1, 2014) [mC/cm ²]	Diff. charge (maximum) [mC/cm ² /d]	# of measurements	# of QE scans	Comments
PHOTONIS XP85112	9001223	7852	13.5	151	14	Start: 23 Aug. 11 ongoing
	9001332	4948	21.8	55	7	Start: 12 Dec. 12 ongoing
	9001393	1879	11	19	3	Start: 23 Jan. 14 ongoing
Hamamatsu R10754X	JT0117 (M16)	2086	14.1	86	7	Start: 23 Aug. 11 Stop: 24 Jul. 12
	KT0001 (M16M)	4331	30.1	31	5	Start: 20 Aug. 13 ongoing
	KT0002 (M16M)	2312	20.1	26	6	Start: 21 Oct. 13 ongoing
BINP	1359	3616	10.6	90	8	Start: 21 Oct. 11 Stop: 06 May 13
	3548	5925	11.8	128	11	Start: 21 Oct. 11 ongoing



MCP-PMT LIFETIME RESULTS



Summary of lifetime-improved MCP-PMTs

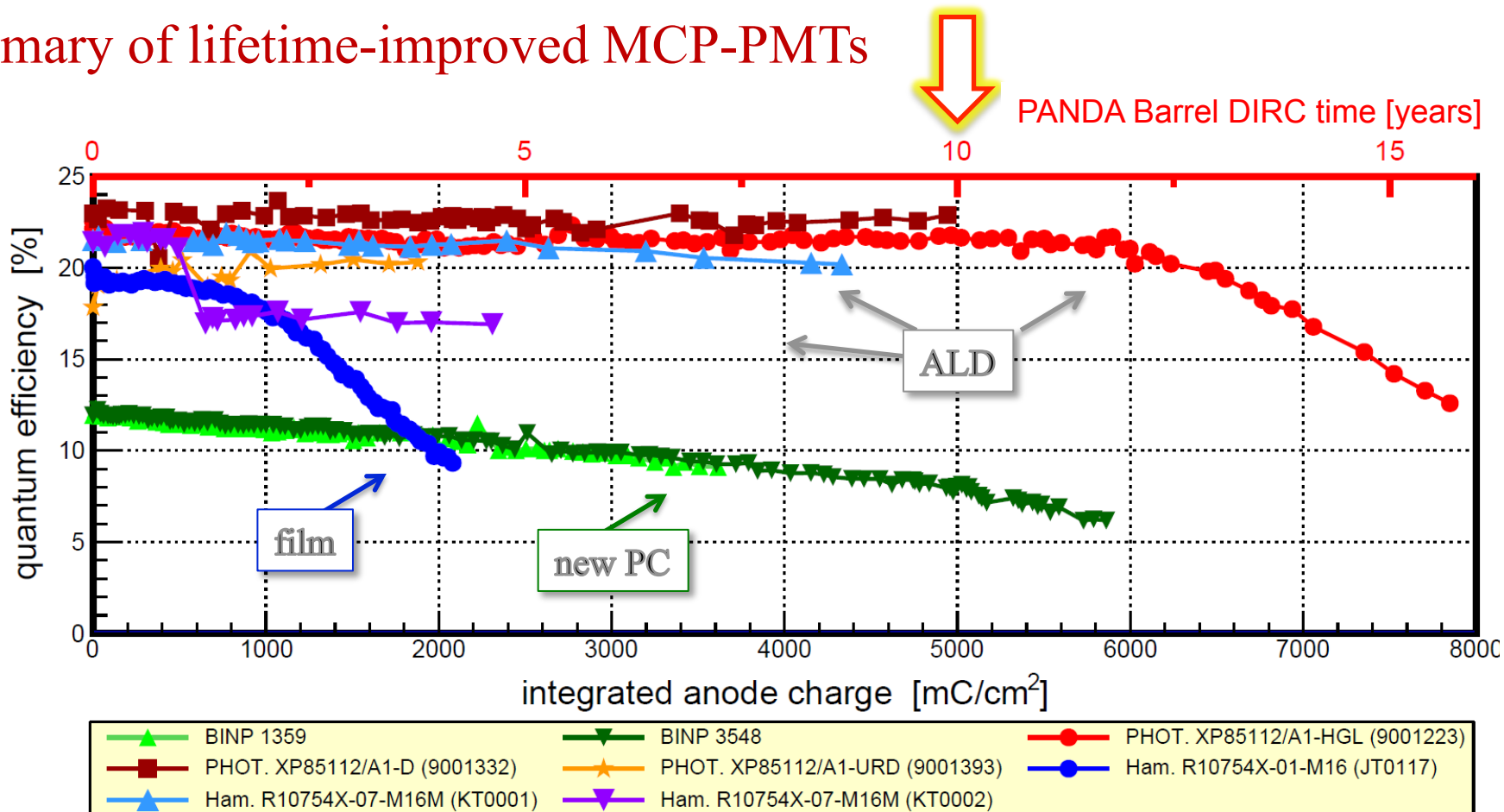

Latest MCP-PMTs with ALD technique meet all requirements for the PANDA Barrel DIRC.



MCP-PMT LIFETIME RESULTS



Impossible to describe all our results (3+ years) or the excellent MCP-PMT lifetime studies by Belle II and TORCH groups in this talk.

In the remaining time: a few highlights

Gain vs. integrated anode charge

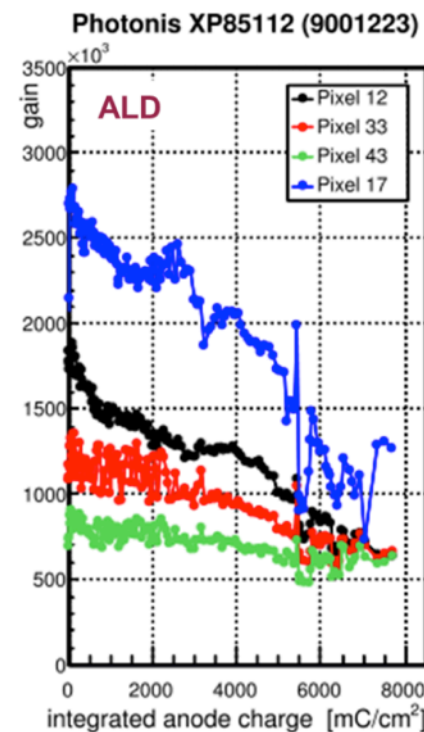
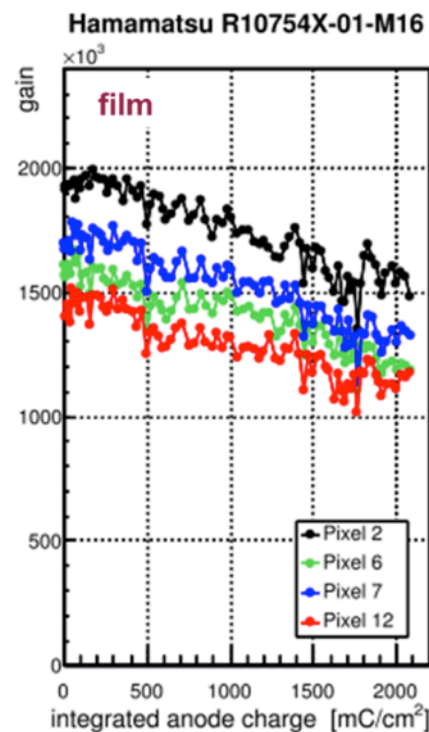
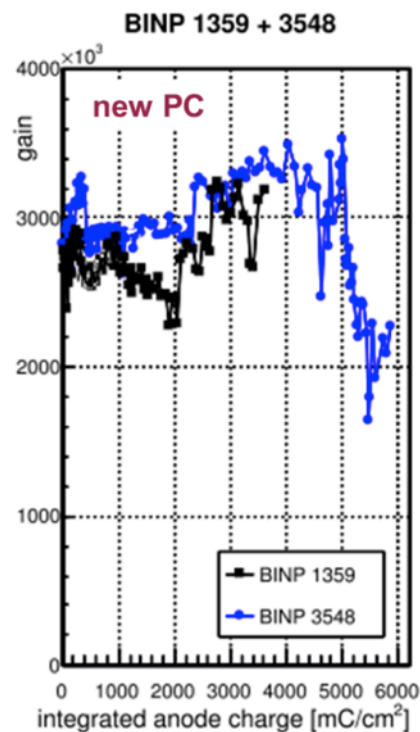

→ Only moderate gain changes, can be recovered by raising HV



MCP-PMT LIFETIME RESULTS



Quantum efficiency for different wavelengths vs. integrated charge

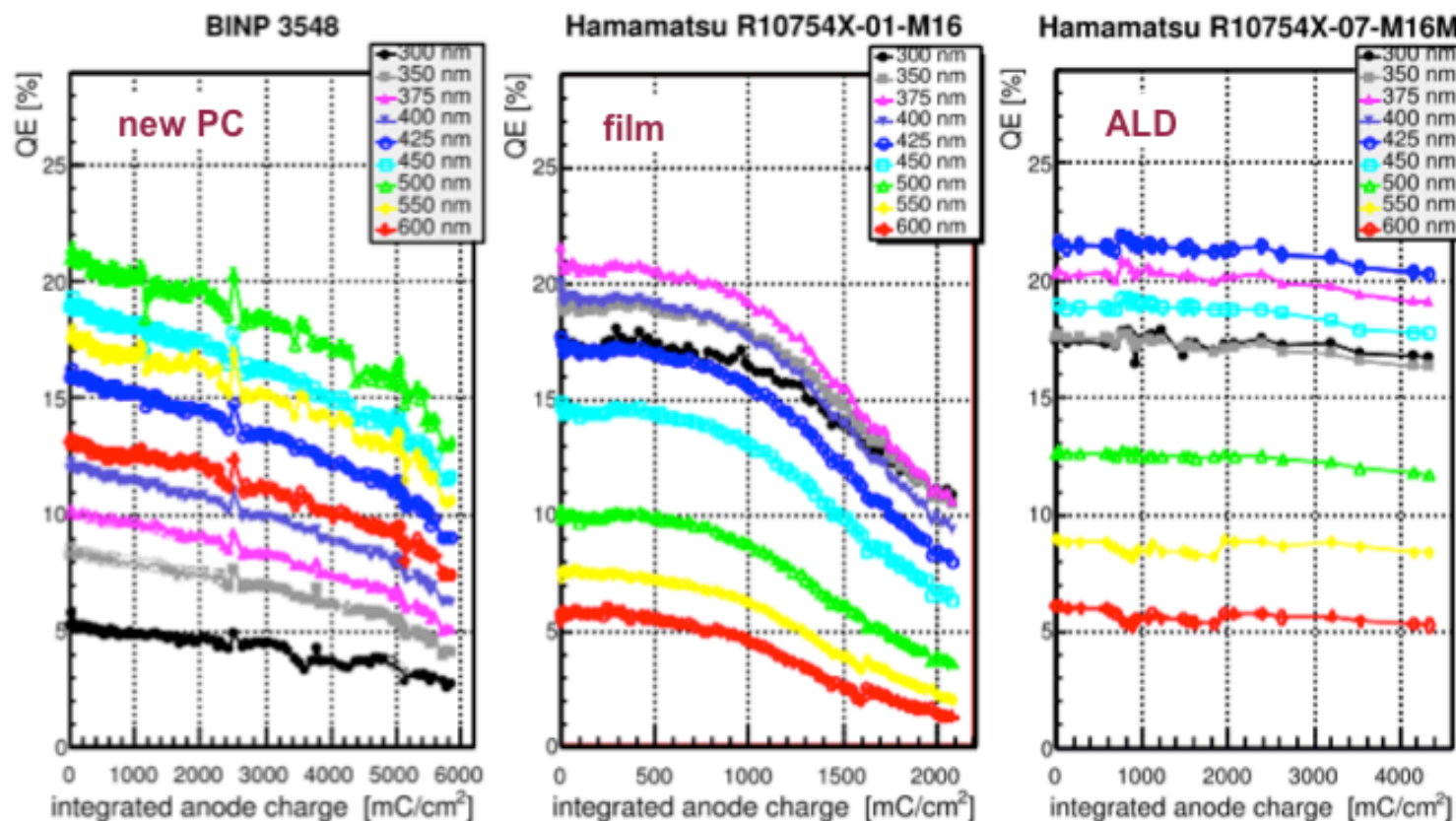

- BINP new PC: continuous QE degradation
- Hamamatsu film: QE drops significantly after $\sim 1 \text{ C/cm}^2$
- Hamamatsu ALD: only minor QE degradation at $>4 \text{ C/cm}^2$



MCP-PMT LIFETIME RESULTS



Quantum efficiency for different wavelengths vs. integrated charge

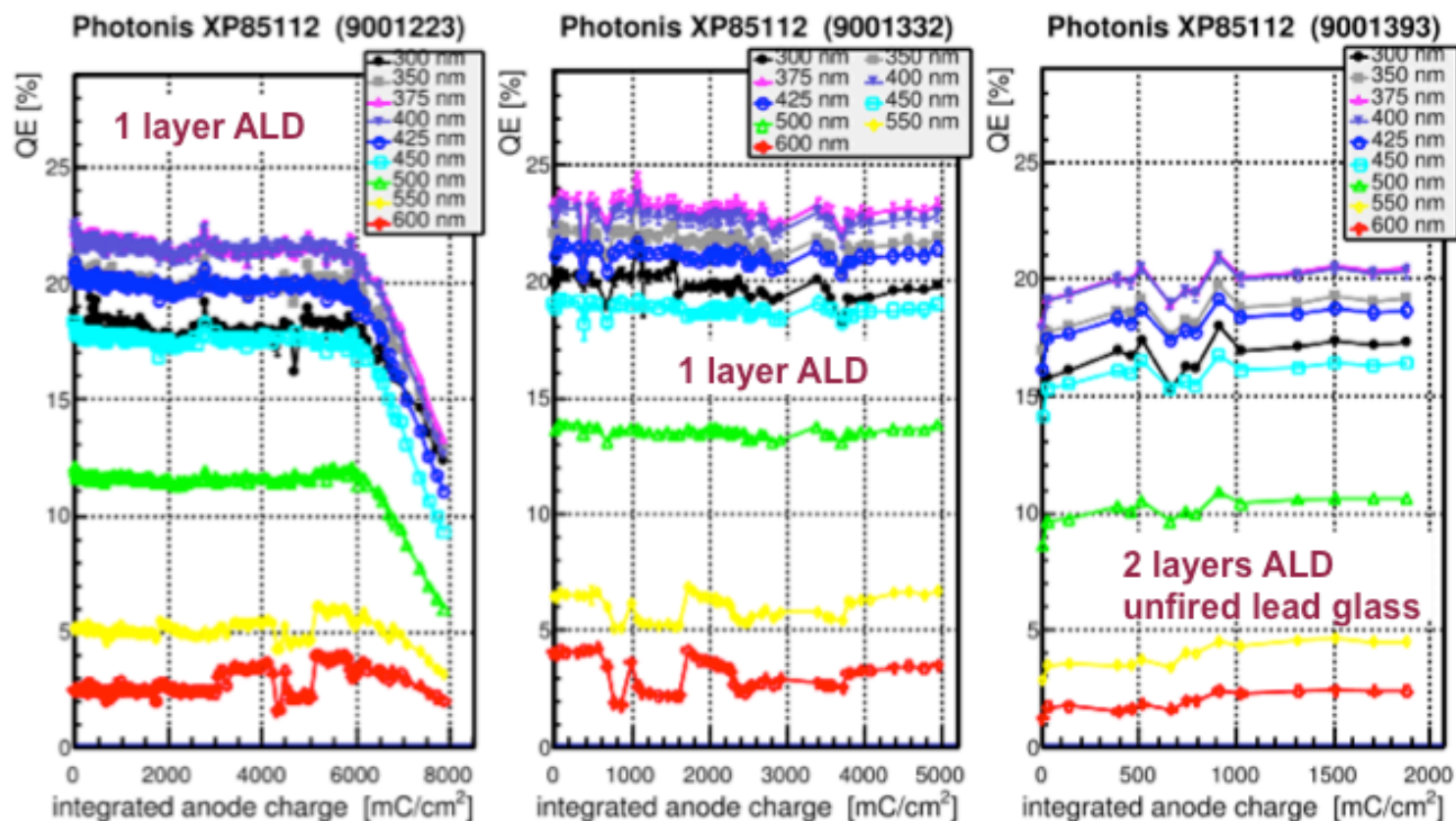

PHOTONIS Planacon with 1 layer ALD: no QE loss up to 5 C/cm²

#9001223: steep QE drop after 6 C/cm²

Latest Planacon with unfired lead glass, 2-layer ALD process: no QE loss yet at 2 C/cm².



Quantum efficiency scans (372nm) for different integrated charges

film **Hamamatsu R10754X-M16**

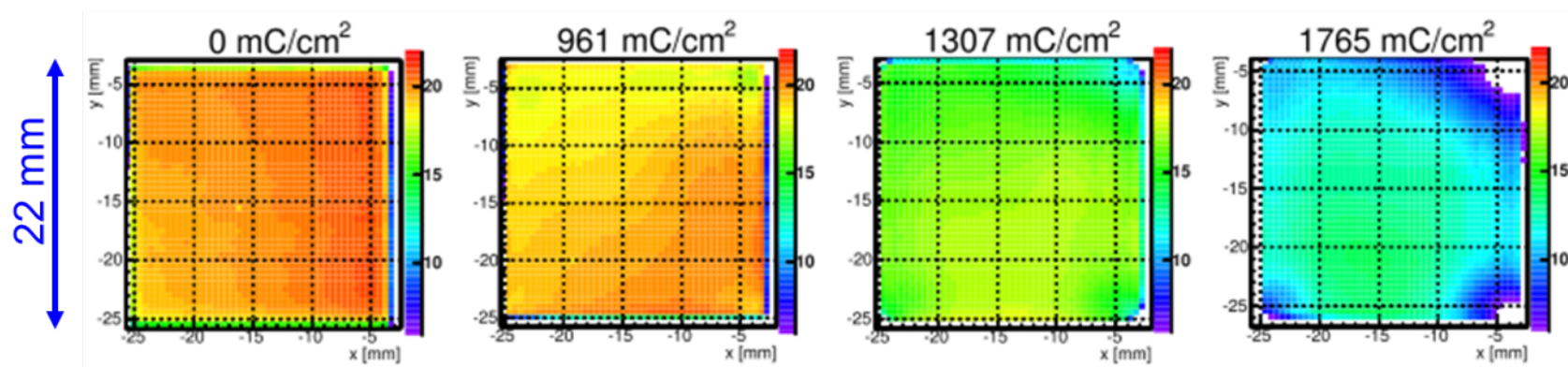

new PC **BINP 3548**

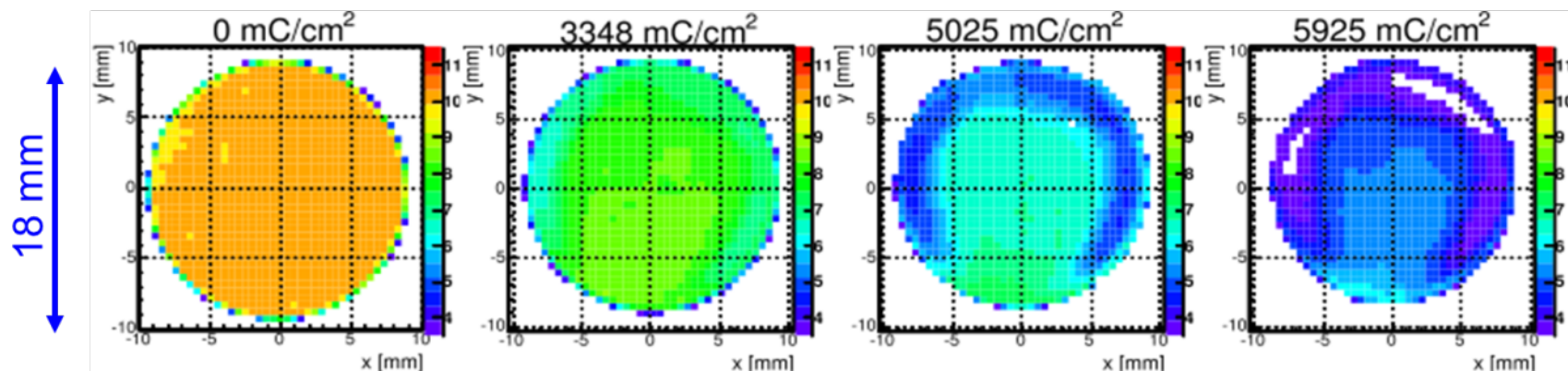

→ QE degradation evolves from rims and corners, both film and new PC fail.

MCP-PMT LIFETIME RESULTS



Quantum efficiency scans (372nm) for different integrated charges

ALD PHOTONIS XP85112 (9001223)

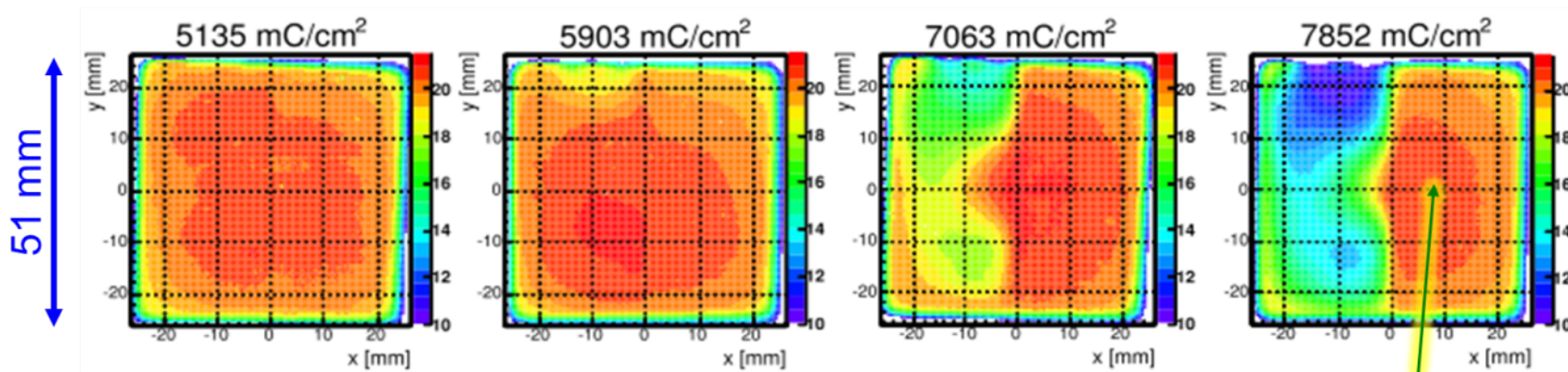

right half of tube
not illuminated

ALD PHOTONIS XP85112 (9001332)

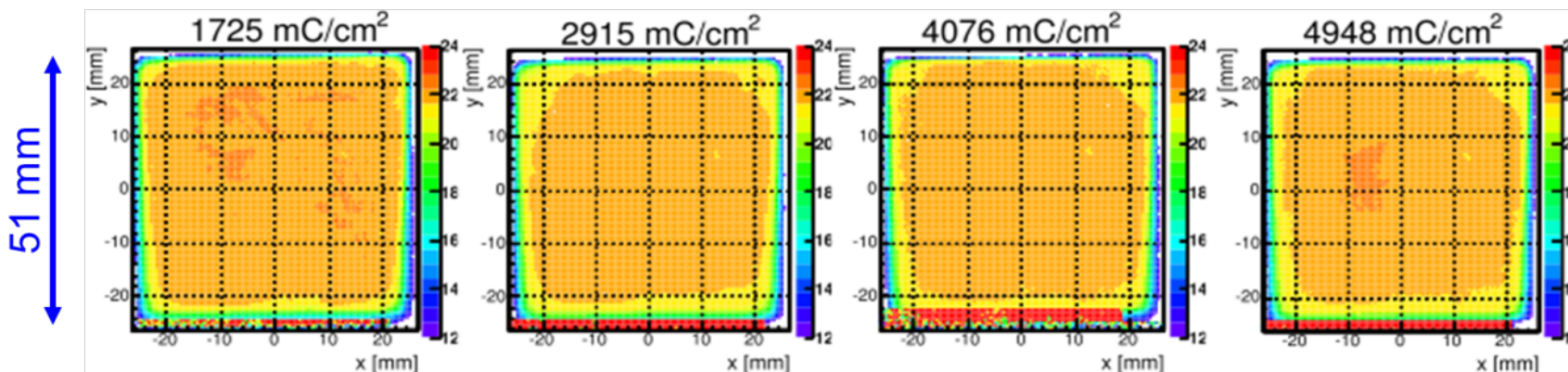

→ no visible QE degradation up to 6C/cm², loss limited to illuminated half.



MCP-PMT LIFETIME RESULTS



Relative quantum efficiency for different wavelengths vs. integrated charge

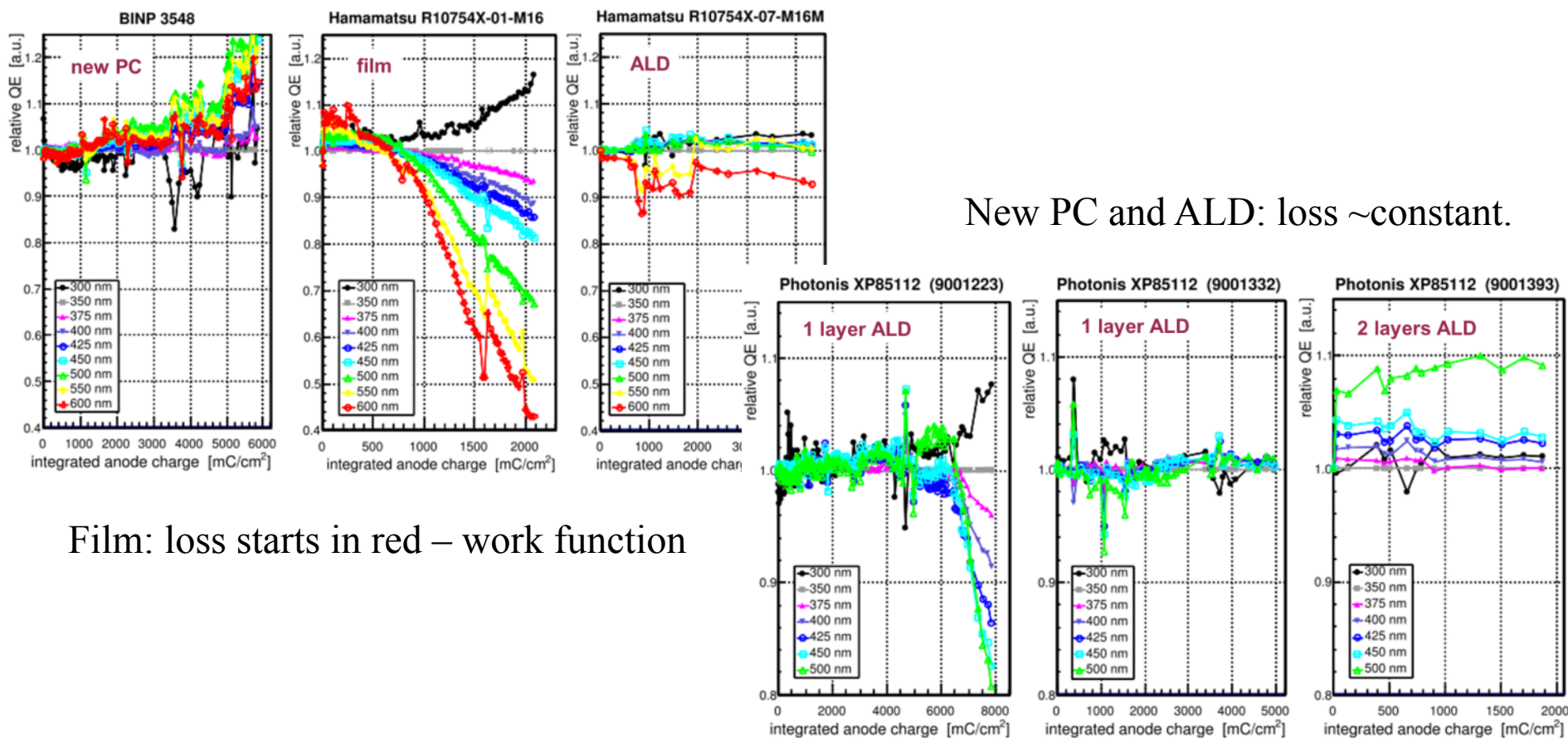

New PC and ALD: loss ~constant.

Film: loss starts in red – work function

→ Clear difference in wavelength-dependent aging between different methods.



AGING STUDY SUMMARY



Spectacular lifetime increase of latest MCP-PMTs due to recent design improvements.

Equipping the two PANDA DIRCs and other high rate RICH counters (TOP, TORCH, DIRC@EIC,...) with MCP-PMTs seems possible.

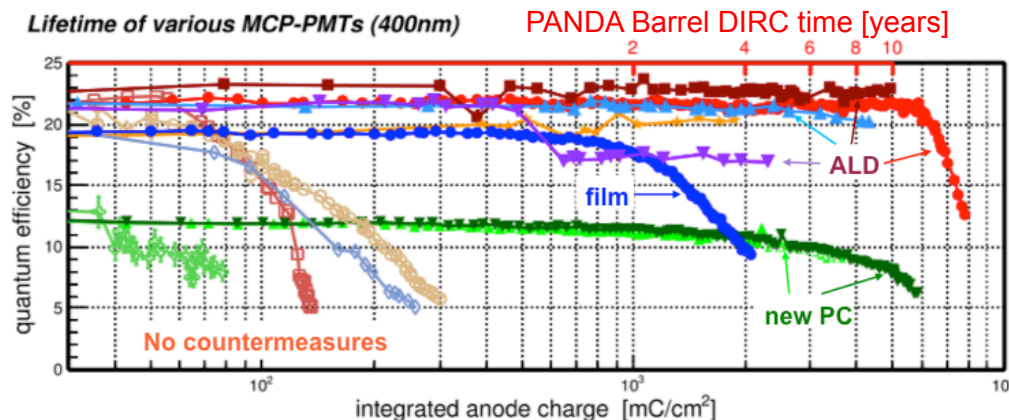

Application of ALD technique appears to be most promising single step (>5 C/cm² anode charge now feasible).

Similar good performance observed in R&D for Belle II TOP and for TORCH.



See presentations at workshop or at RICH 2013
K. Matsuoka,
T. Gys, J. Milnes

Further improvements could possibly be reached by combining ALD with

- modified photo cathodes (see BINP tubes);
- MCP materials with less outgassing (e.g. borosilicate glass instead of lead glass).



Quantum efficiency scans – sensor active areas on same scale.

BINP (new PC)

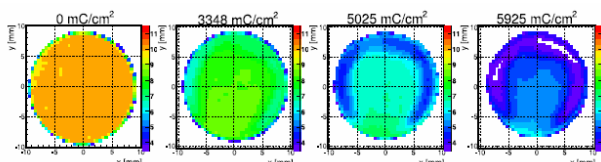

Hamamatsu (film)

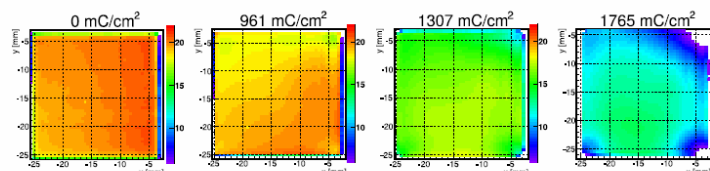

right side
not illuminated

PHOTONIS (ALD)

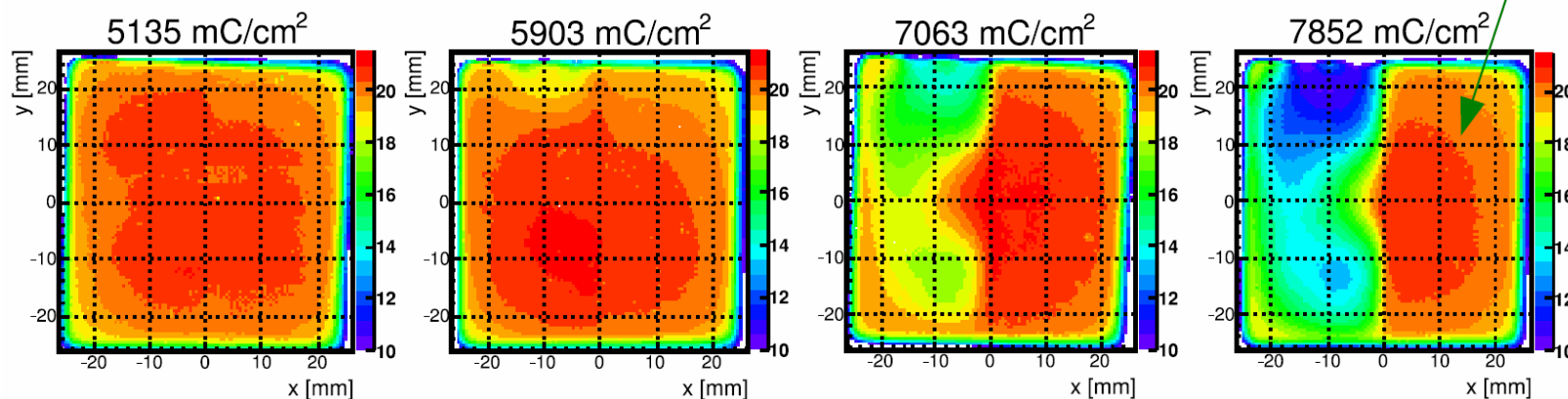

→ PHOTONIS Planacon has major advantage in sensor size/geometric efficiency

... but: expecting new prototype 2 inch Hamamatsu 8x8 MCP-PMT this month;
will also be studied in aging setup, together with 6x128 prototype tube.



MCP-PMT PERFORMANCE



Compilation of data by J. Va'vra, SLAC

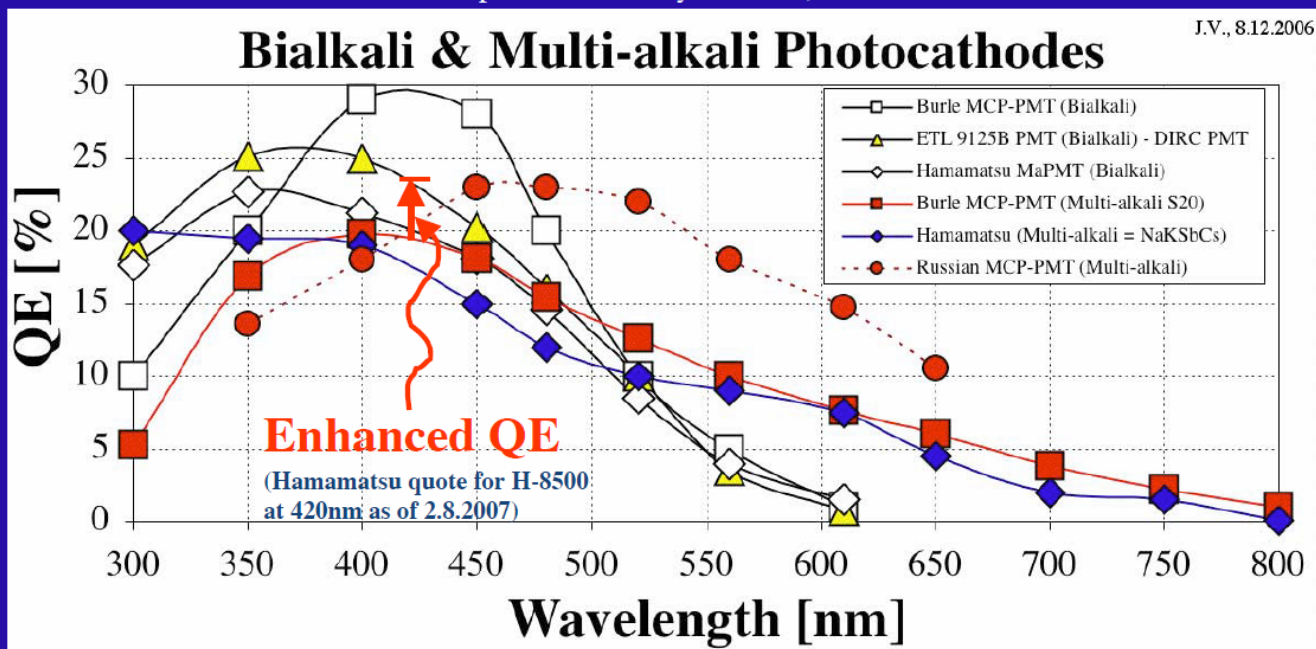

*Planacon with 40-45% peak QE?
Yes, please!*

- We will see that moving towards the red wavelength range reduces the time spread of the photoelectrons at the photocathode. However, the Cherenkov light yield is smaller for red wavelengths.
- For example, Photonis Multi-alkali photocathode, which I am not allowed to show, would yield half of photoelectrons from the quartz radiator compared to Burle Bialkali on MCP-PMT, all else equal.

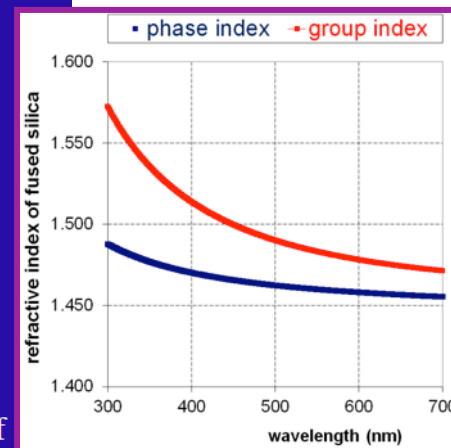

12/27/07

J. Va'vra, Photon Detectors, AIS
SLAC

11

→ extended QE range not necessary for DIRCs, chromatic errors start to dominate DIRC resolution, but higher blue peak QE important for photon yield.



MCP-PMT PERFORMANCE



Factors influencing PDE: **tail and dead space**

C. Field, T. Hadig, D.W.G.S. Leith, G. Mazaheri, B. Ratcliff, J. Schwiening, J. Uher, and J. Va'vra, SLAC
 RICH 2004, Cancun, Mexico, Nucl.Instr. & Meth., A553(2005)96-106

MCP-to-Cathode distance ~ 6 mm

Burle 85011-501 Nominal design:

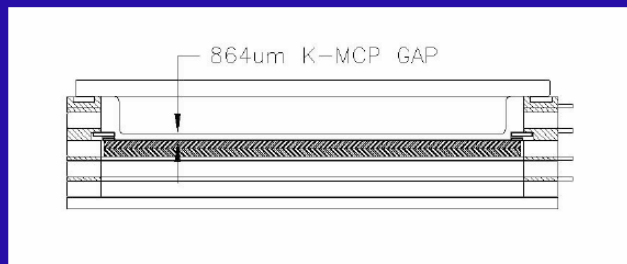
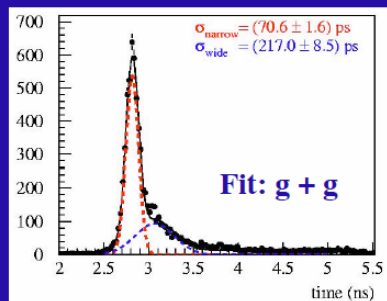

Penalty of this design: the efficiency drops to zero near edges.

MCP-to-Cathode distance ~ 0.85 mm

Burle 85011 430 Drop Faceplate design:

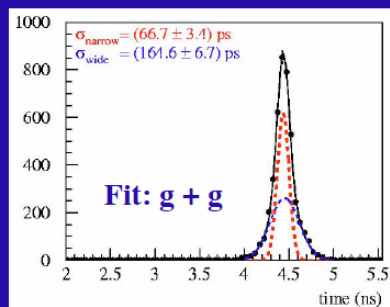

L should be small:

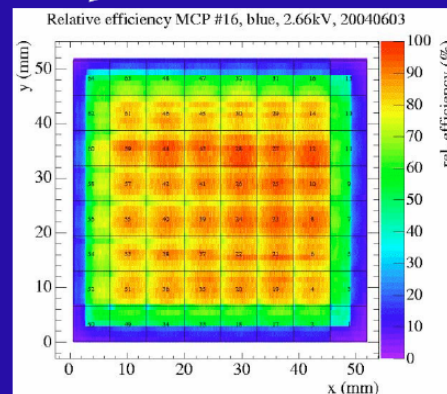
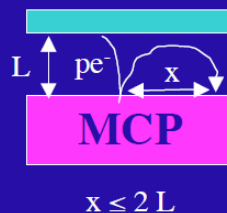

12/27/07

J. Va'vra, Photon Detectors, AIS
 SLAC

12

→ smaller gap between PC and MCP-PMT probably required for PANDA.

Need to optimize *rms* of photon arrival time, not " σ_{narrow} ".



MCP-PMT PERFORMANCE



Charge sharing not expected to be a problem for Barrel DIRC (6.5mm anode pitch) but could be an issue for Disc DIRC (0.5mm anode pitch).

Magnetic field will help a lot (Larmor radius), charge sharing effects decrease
– smaller gap between MCP and anode plane would be useful for lab QA tests.

PHOTONIS XP85012 (8x8)

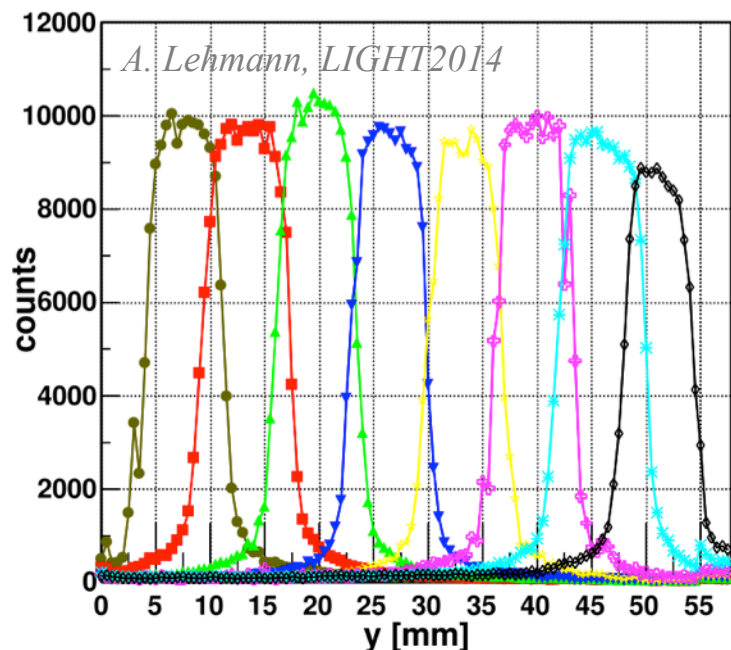

PHOTONIS XP85132-Q-MD2 (3x100)

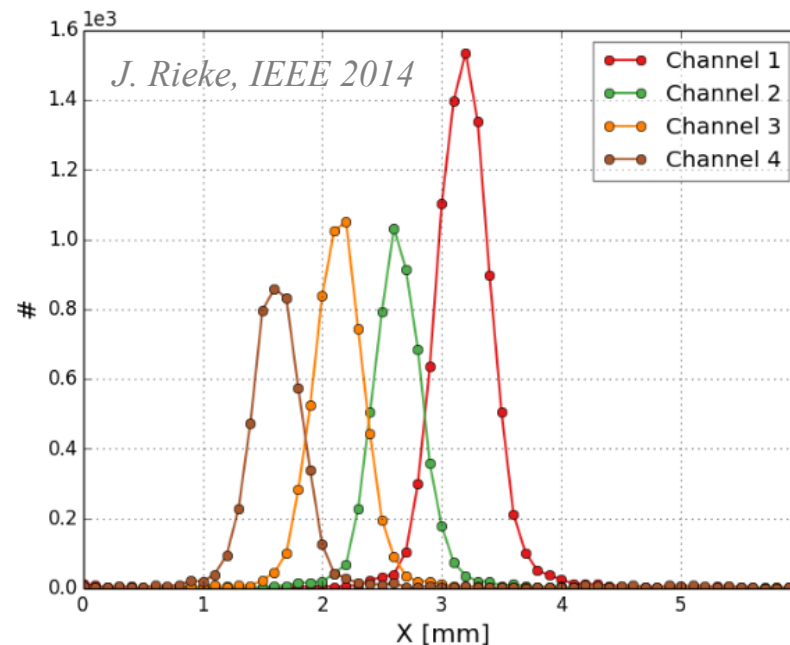



MCP-PMT PERFORMANCE



Multi-hit capability is important. Expect up to 100 photoelectrons per particle for steep forward/backward angles in narrow pattern on MCP-PMT array.

Example: PANDA Barrel DIRC prototype 2014 (simulation)

→ up to 20 detected photons per Planacon MCP-PMT (more in full detector).

Need to be able to cleanly determine hit position (individual pixel readout).

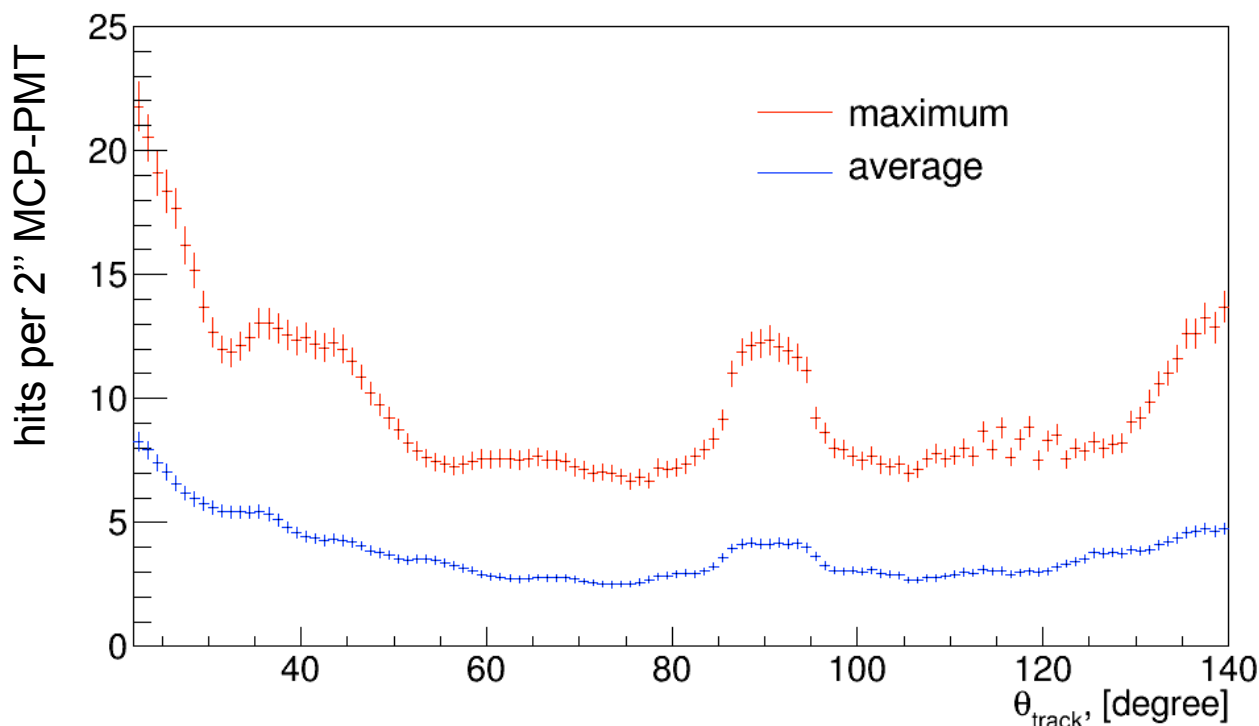

MCP-PMTs are of critical importance to PANDA Barrel DIRC and Endcap Disc DIRC counters with sensors in high B fields.

Biggest concern 3 years ago: premature aging of photocathode
→ major achievement: appears to be solved (but needs to be closely monitored).

Disc DIRC needs MCP-PMT with $\sim 0.5\text{mm}$ anode pitch in one direction, coarse pitch in orthogonal direction
→ study of two candidate prototype tubes is just starting.

Smaller gap between photocathode and first MCP very desirable to improve *rms* of photon timing.

Higher (blue) peak QE, collection efficiency, active area ratio are all very valuable for DIRC counters.

Looking forward to the next generation MCP-PMTs.

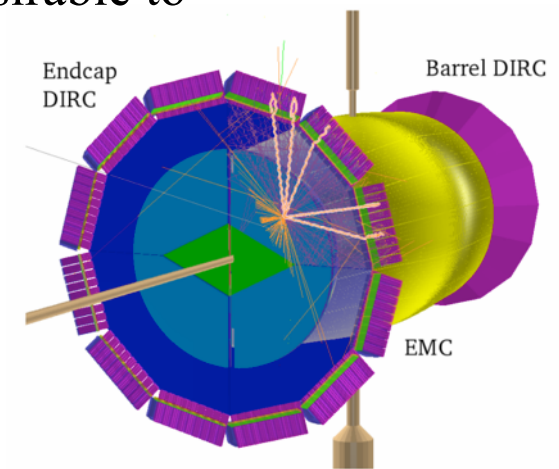

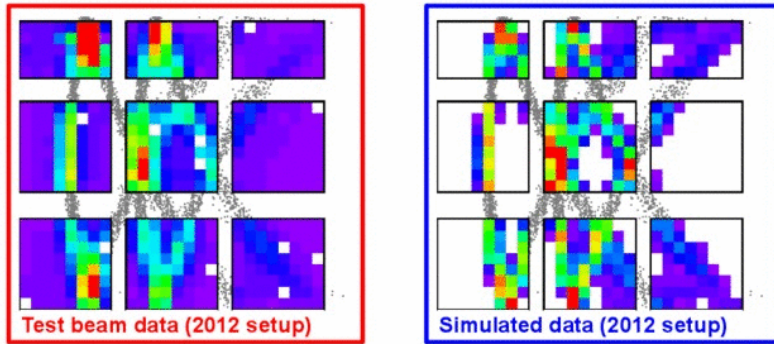

56° Polar angle

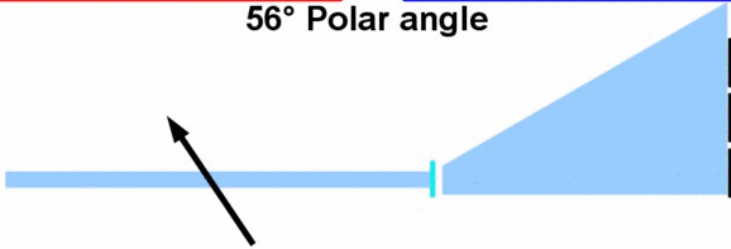

Hit patterns for 2012 prototype with narrow bars and fused silica prism for different polar angles.

Geant simulation of hit pattern for narrow bars and oil tank geometry for different polar angles.

