

E4R POWER SYSTEM for HTS MAGNET WIRE TEST



STEVE HAYS
AD E/E SUPPORT
09.11.2009

Two Power Test are Planned on Conductor



- First is to Ramp a magnetic field and measure the losses in the conductor as a function of the angle that the field lines pass through.
- We will ramp the magnetic field with the conductor at different angles and measure the losses.
- Second is to Ramp to the conductor to operating current at fast ramp rates and measure the losses.
- The plan is to run this test without the magnetic core around the conductor.

Power Equipment Used for Loss Measurements

Magnet that the conductor will be inserted into and then ramped.

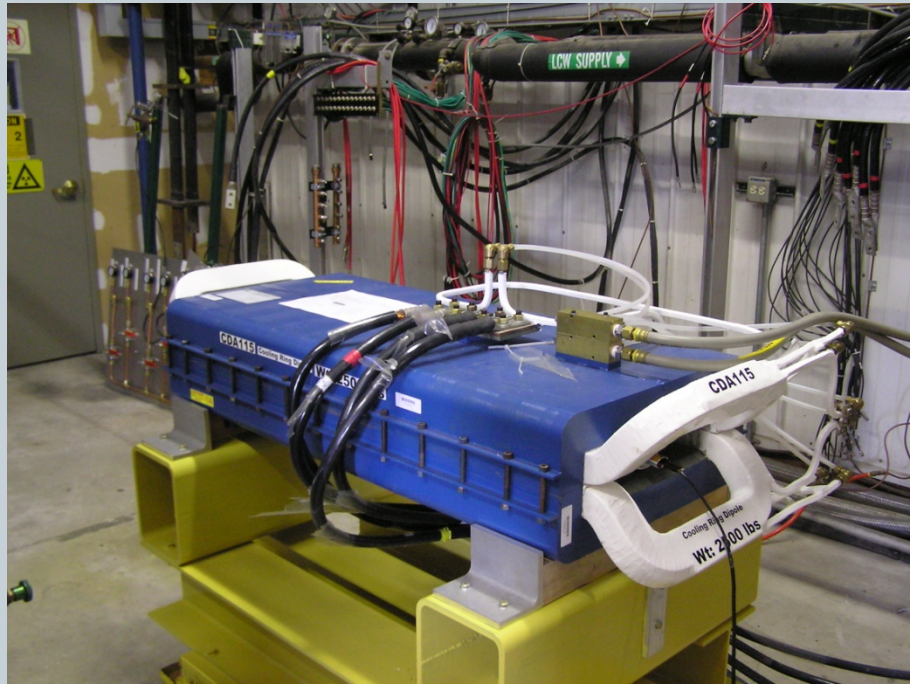

Power Supply that will be used to ramp the magnet. The supply is 75v@1000a.



Fast Ramping Field in Test Magnet

- Channel 1 is a Group 3 hall probe with a gain of $0.3\text{V} = 0.3\text{T}$.
- The plot on the right shows a test at $5\text{T}/\text{sec}$.
- Channel 2 is a Danfysik Transducer with a gain of 100 amps/volt .
- The power supply current is 550 amps peak . $DI/dt = 8500\text{ amp/sec}$
- The supply is operating at 6Hz and we can run 15Hz if needed to improve the loss measurement.

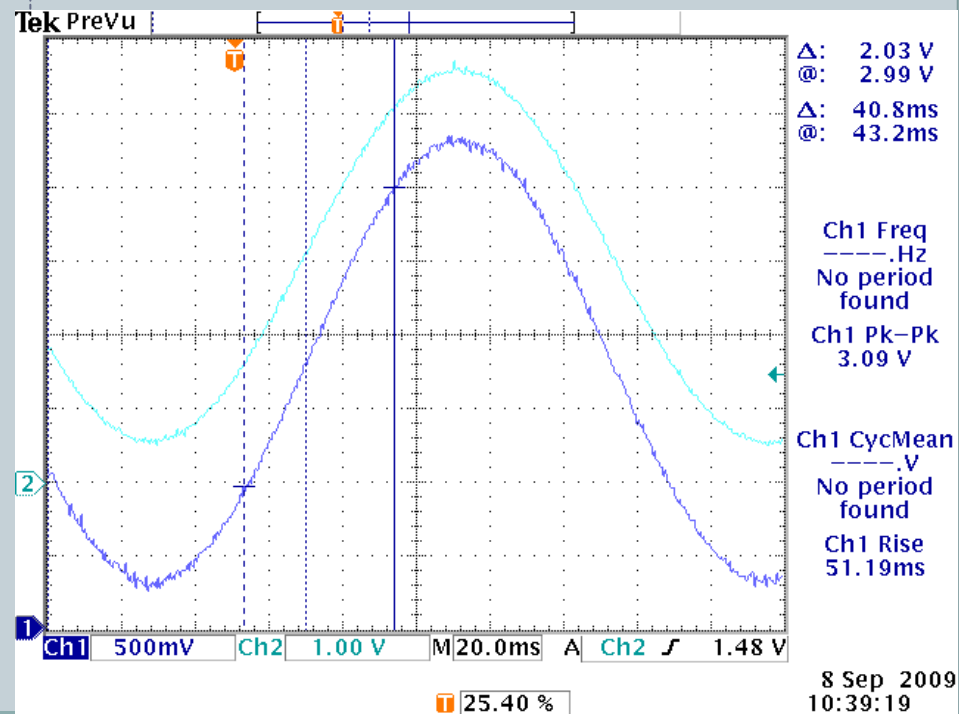

Setup for the High Current Test

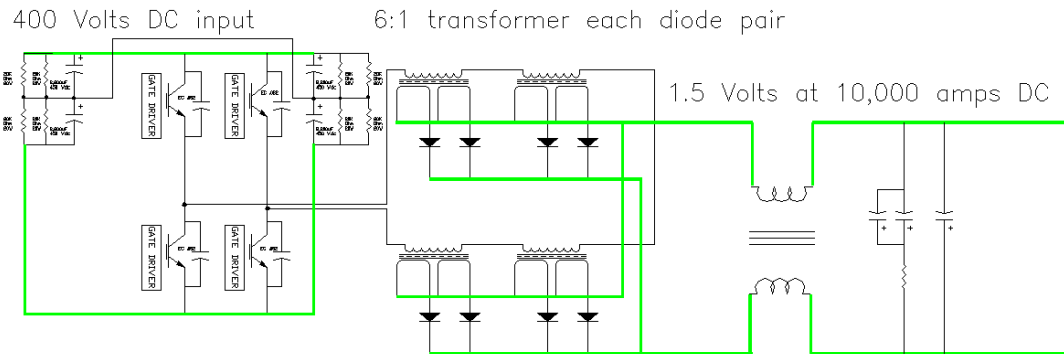
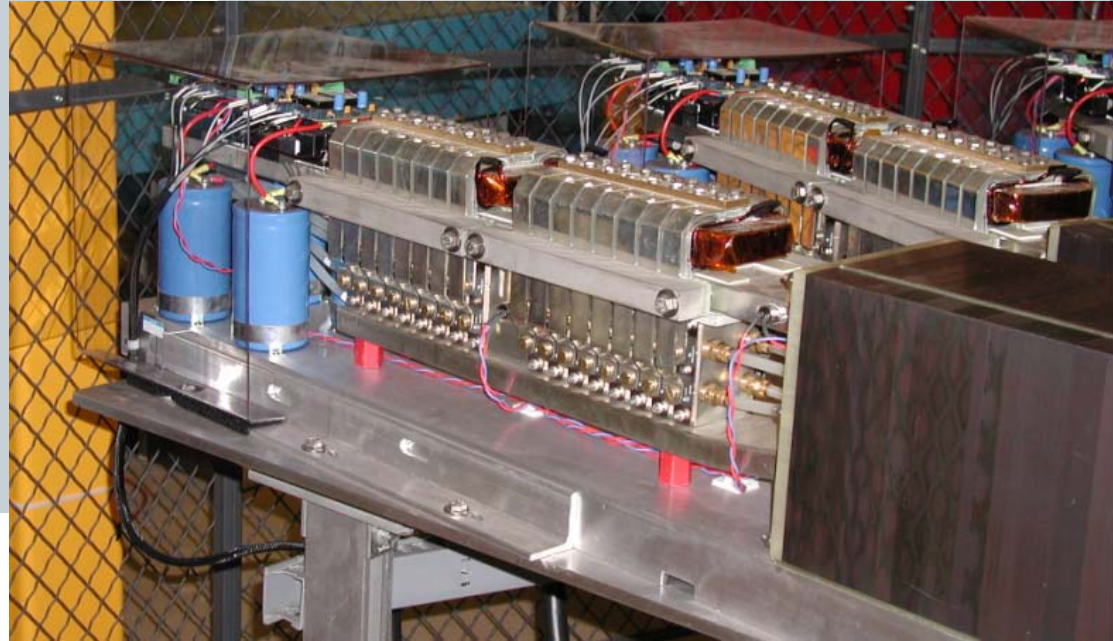

**VLHC Switcher Power Supply
Cell. 1.5 Volts @15,000 amps**

Powerex PM300DSA120
Intellimod Module (IPM)
Single Phase IGBT inverter module

64 diodes in parallel
Low Vf SCHOTTY Barrier Dodes
MBRP60035CTL Vf 0.55v @300 amps

Power Supplies for High Current Test

- These supplies will be operated in voltage mode.
- They can be configured in either series or parallel or series-parallel as needed for all high current testing.



**20Kw PEI Power Supplies
200V@100A each with a
filter.**

Quench Protection for Single Conductor

- 8 Channel Temperature Monitor
- Each Channel has an Alarm contact output that can be used to trip power supply.
- Labview interface for data logging



Single Bus Loop Quench Protection

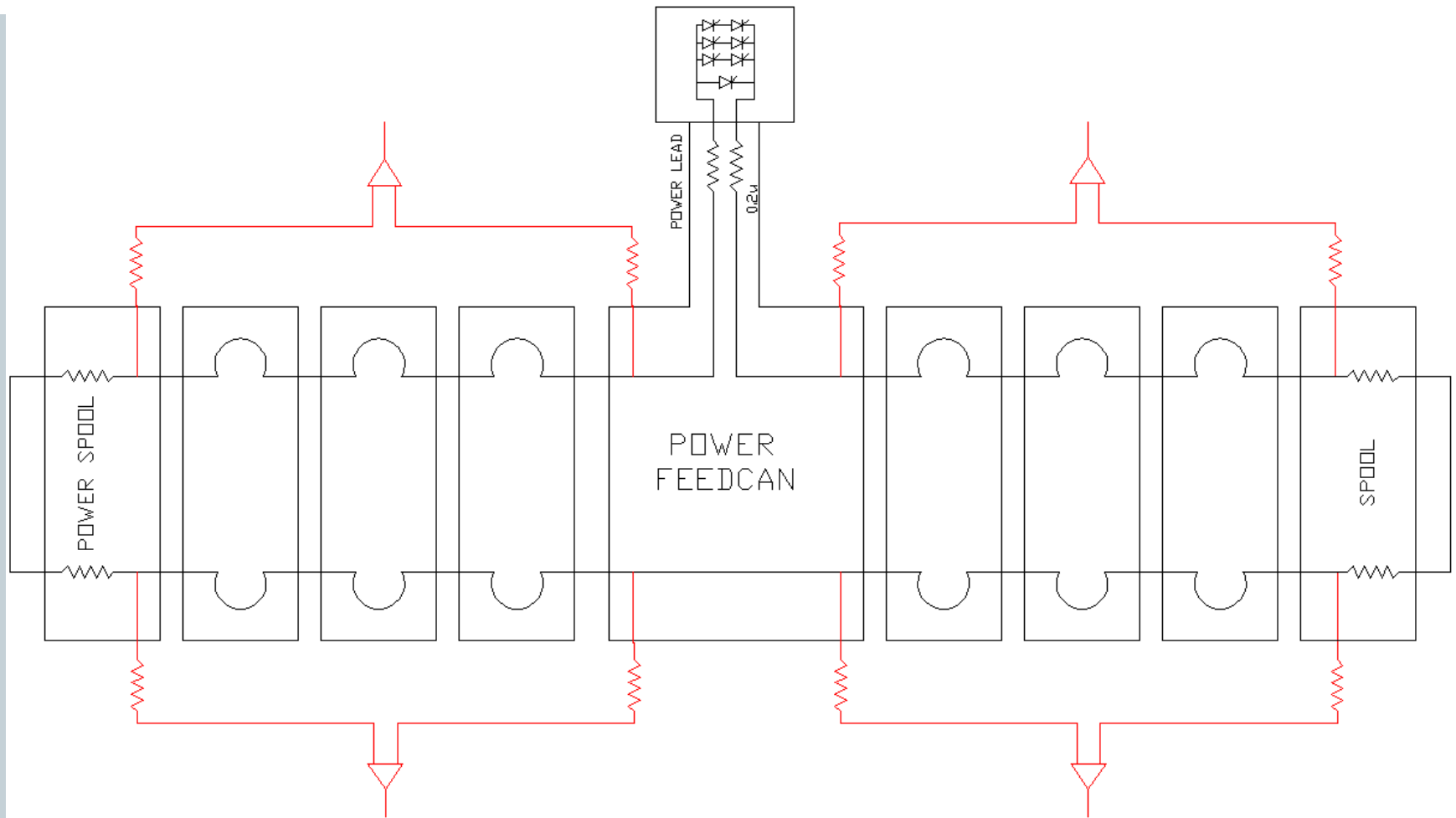

Additional R&D Effort



- **We need two items to support a magnet system.**
 - A DCCT that can measure 70Kamps.
 - ✦ This could be a cold device that will have a small aperture.
 - ✦ Can be constructed in a spool as part of the normal system.
 - ✦ It will need to operate even through a quench so it can not be SC.
 - Second we need a high current dump switch.
 - ✦ This should be SC type using HTS wire.
 - ✦ Needs complete development because of the high current.
 - I have a paper on low current designs that can be used as a starting point.
 - We should use HTS wire with SS substrate because of a factor of 5 improvement in warm resistance.
 - It may also need a cooling flow controller that is a function of the operating current. (the lower the magnet current the warmer it should run to ensure we can trigger the switch).
 - It would be good to have when we move to the full magnet test.