



ESnet updates: The ANI Project and more

Brian Tierney, ESnet,

Open Science Grid Storage Forum, Sept 21, 2010





Talk Overview

ANI Project

- 100G prototype network
- Testbed

ESnet's network knowledge base: fasterdata.es.net

perfSONAR update

New public "Disk I/O performance" test hosts

ANI: Advanced Network Initiative



Project Start Date: September, 2009

Funded by ARRA for 3 years

Designed, built, and operated by ESnet staff

1 of 3 ARRA “Advanced Network Initiative” (ANI) projects in the DOE

- ANI 100G Prototype
- ANI Network Testbeds
- 4 ANI research projects

DOE's Advanced Networking Initiative



ANI Project scope (\$66.8M):

- Build an end-to-end 100 Gbps prototype network
 - Handle proliferating data needs between the three DOE supercomputing facilities and NYC international exchange point
- Build a network testbed facility for researchers and industry
 - Includes \$5M in network research that will use the testbed facility

Magellan:

- Separate DOE-funded (\$32.8M) nationwide scientific mid-range distributed computing and data analysis testbed to explore whether cloud computing can help meet the overwhelming demand for scientific computing
- NERSC / LBNL & ALCF / ANL configured with multiple 10's of teraflops and multiple petabytes of storage, as well as appropriate cloud software

ANI Project Goals



Prototype network:

- Accelerate the deployment of 100 Gbps technologies
- Build a persistent infrastructure that will transition to the production network ~2012
 - Key step toward DOE's vision of a 1-Terabit network linking DOE supercomputing centers and experimental facilities
- Not for production traffic, not routed to the general internet

Testbed:

- Build an experimental network research environment at sufficient scale to usefully test experimental approaches to next generation networks
 - Funded for 3 years, then roll into the ESnet program
 - Breakable, reserveable, configurable, resettable
 - Enable R&D at speeds up to 100 Gbps

ANI 100G Technology Evaluation



Most devices are not designed with any consideration of the nature of R&E traffic – therefore, we must ensure that appropriate features are present and devices have necessary capabilities

Goals (besides testing basic functionality):

- Test unusual/corner-case circumstances to find weaknesses
- Stress key aspects of device capabilities important for ESnet services

Many tests conducted on multiple vendor alpha-version routers, examples:

- Protocols (BGP, OSPF, ISIS, etc)
- ACL behavior/performance
- QoS behavior
- Raw throughput
- Counters, statistics, etc

Nationwide 100G Prototype Network

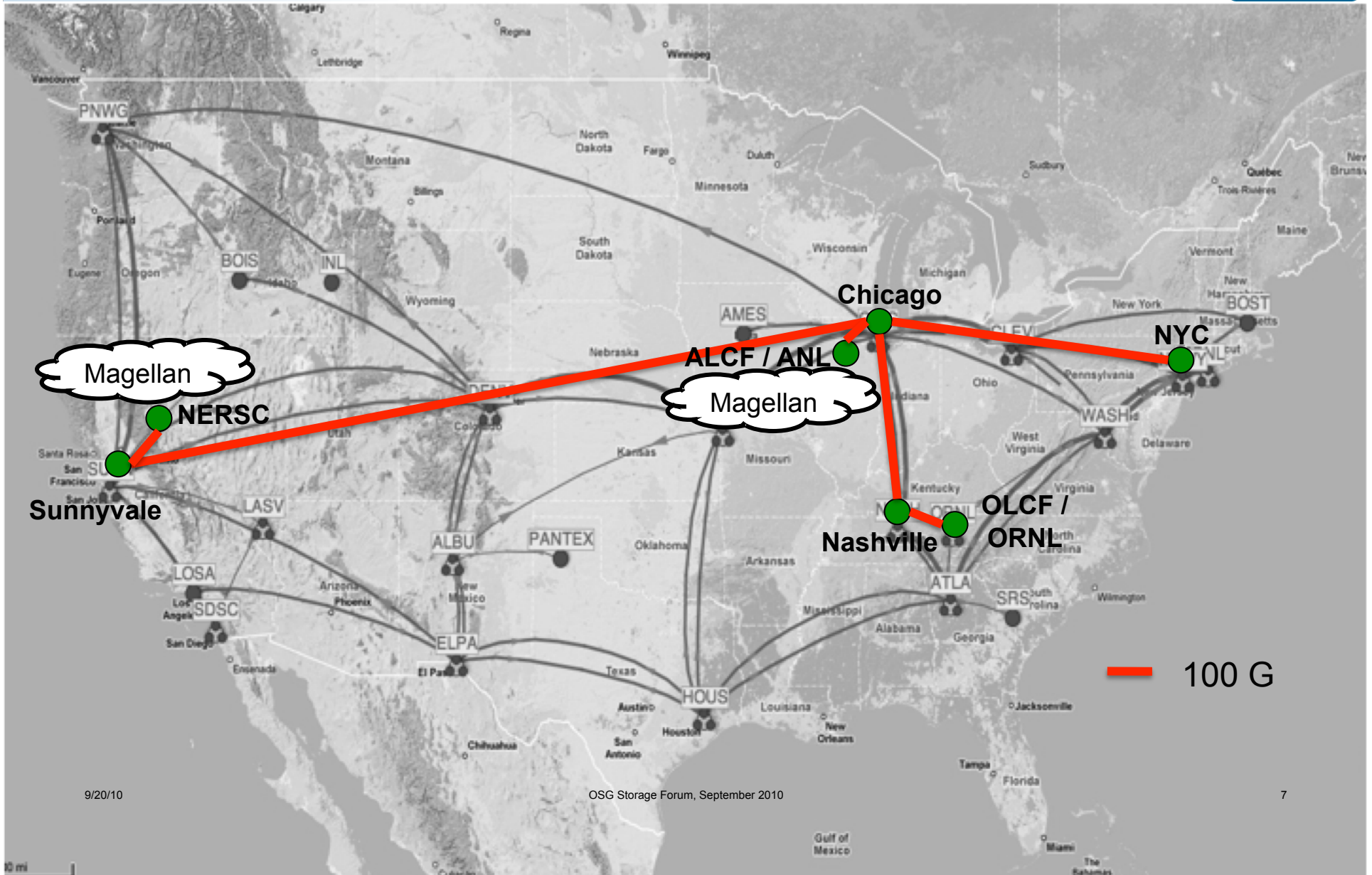

ANI Prototype Network Status Update



RFP issued June 15, asking for:

- 100G Service between MANLAN, ORNL, ANL, and NERSC
- 20-year dark fiber IRU for nationwide footprint
 - Northern route, southern route, SF Bay Area MAN, Chicago area MAN

Responses due Aug 20

Proposals are currently being evaluated

Tentative Schedule for future:

- make a decision on 100G RFP by Oct 1
- DOE approval and contract negotiation: Oct-Dec
- Contract Awarded: December
- 100G Router RFP will be issued early October
- Prototype network ready to begin testing: September, 2011



Testbed Overview

Progression

- Start out as a tabletop testbed
- Move to Long Island MAN when dark fiber is available
- Extend to WAN when 100 Gbps available

Capabilities

- Ability to support end-to-end networking, middleware and application experiments, including interoperability testing of multi-vendor 100 Gbps network components
- Researchers get “root” access to all devices
- Use Virtual Machine technology to support custom environments
- Detailed monitoring so researchers will have access to all possible monitoring data

Sample Projects



Examples of the types of projects the current testbed will support include the following:

- Path computation algorithms that incorporate information about hybrid layer 1, 2 and 3 paths, and support 'cut-through' routing
- New transport protocols for high speed networks
- Protection and recovery algorithms
- Automatic classification of large bulk data flows
- New routing protocols
- New network management techniques
- Novel packet processing algorithms
- High-throughput middleware and applications research



Network Testbed Components

Table Network Testbed consists of:

- 6 DWDM devices (Layer 0-1)
- 4 Layer 2 switches supporting Openflow
- 2 Layer 3 Routers
- Test and measurement hosts
 - Virtual Machine based test environment
 - 4x10G test hosts initially
 - Eventually 40G and 100G from Acadia 100G NIC project
- This configuration will evolve over time

Tabletop: A layered view

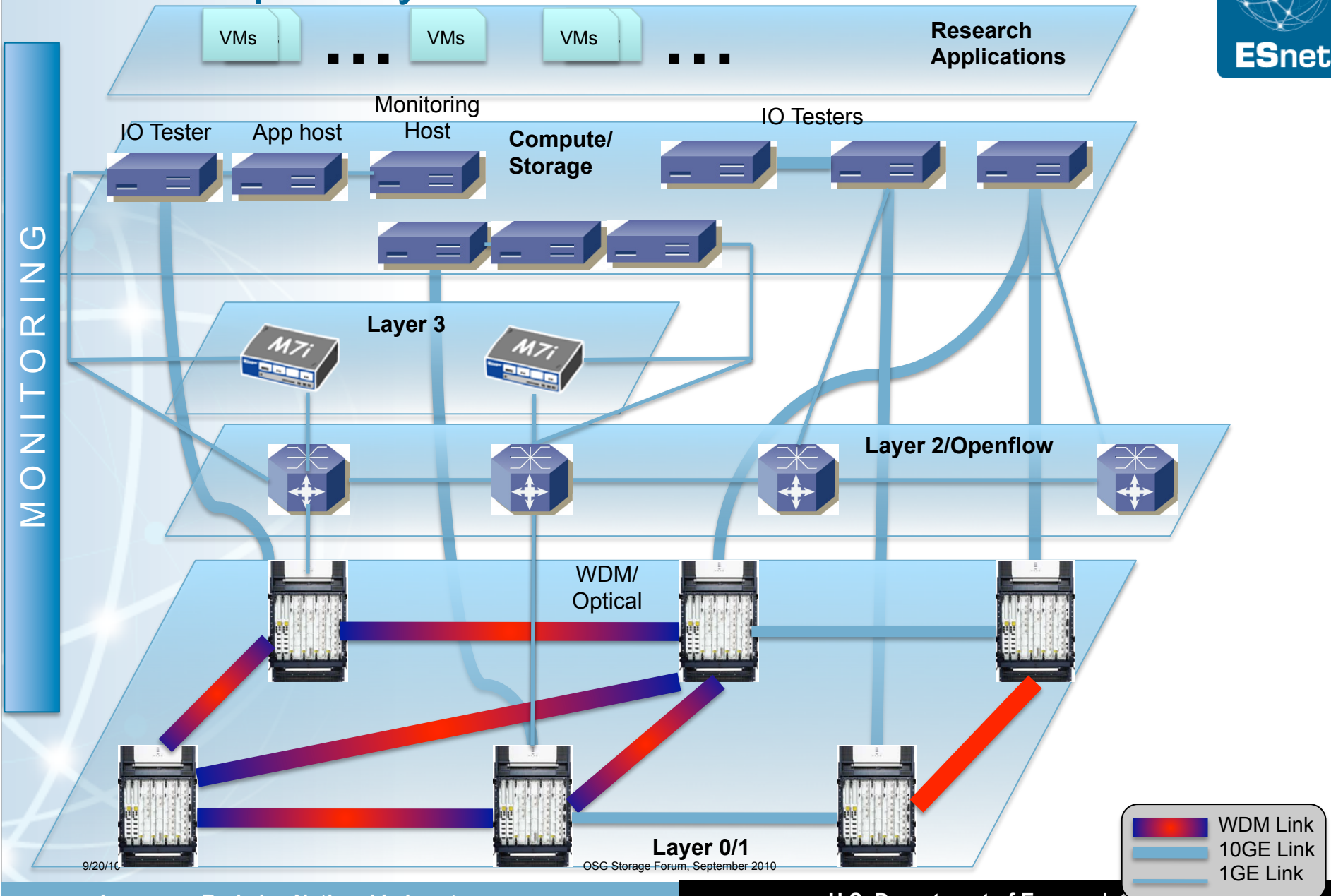

9/20/10

OSG Storage Forum, September 2010



Testbed Status

Tabletop Testbed available for researchers to log in as of late June.

- researchers are logging in, configuring VMs, running tests, etc.
- can reserve testbed components using Google calendar.

User documentation mostly complete:

- <https://sites.google.com/a/lbl.gov/ani-testbed-user-guide/>

Per-project Monitoring set up:

- <https://tb-webdav-1.es.net/ganglia/>

Testbed-support@es.net email list is quite active

A few remaining tasks to be done: e.g.: web interface to claim reserved resources

For Phase 2: RFP for the Long Island dark fiber ring has been signed and construction has started.



Testbed Access

Proposal process to gain access described at:

<https://sites.google.com/a/lbl.gov/ani-testbed/>

Currently there are 3 DOE-funded projects that have access to the testbed

- 3-4 more are waiting for 40G capability

First round of proposals are due Oct 1

- Accepted proposals announced Jan 10, 2011

Proposal review committee members:

- DOE Lab: Phil DeMar, FNAL; Les Cottrell, SLAC
- University: Ben Yoo, UC Davis
- Industry: Bikash Koley (Google); David Richardson (Amazon); Steve Wolff (Cisco); Wes Doonan, Adva
- International: Cees De Laat, U Amsterdam; Mauro Camponelli, GARR; Tomohiro Kudoh, AIST
- Other: Jerry Sobiesky, Nordunet; Kevin Thompson, NSF

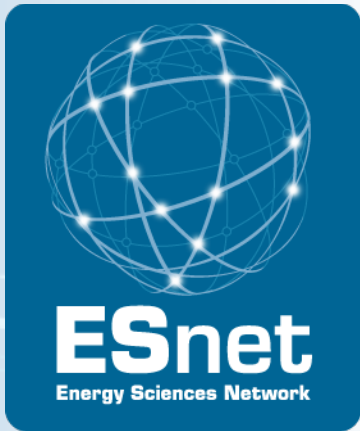

fasterdata.es.net

ESnet's Network Performance Knowledge Base

Network Performance Knowledge Base:

<http://fasterdata.es.net/>



Collection of instructions, theory, tutorials, and best practice documents

- Principal maintainers: Eli Dart and Brian Tierney, with contributions from ESnet engineering staff

Focused on the scientific community

- High-performance data transfer
- Commonly-deployed tools
- Incorporates lessons learned and best practices derived from ESnet staff experience solving customer problems
- Built on foundation of data from Brian Tierney's TCP tuning site, developed over 10 years

Easy quick-reference Instructions for deploying common tools

- Many configuration instructions are cut-and-paste for ease of use and reduced errors
- Configuration guides for common network equipment (e.g. Cisco routers)

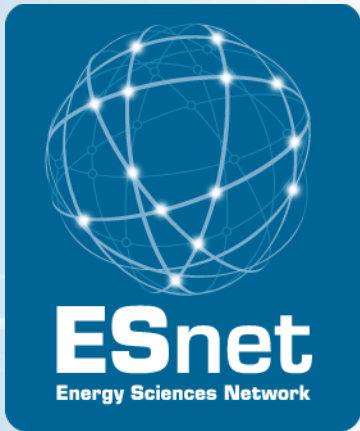

ESnet perfSONAR Service



Why perfSONAR?

PerfSONAR & the wizard gap

- ESnet is deeply involved in perfSONAR because typical users can't get what they need out of the network.

PerfSONAR allows us to:

- Find and fix problems that impact performance
- Help users understand network problems in their domain
- Demonstrate network capabilities & establish baselines
- Make sure problems stay fixed
- Quantify multi-domain network performance

ESnet Engineers are working 2-3 network performance problems in a typical week

- Problems are usually configuration/tuning related, or “soft failures”

ESnet perfSONAR Infrastructure



- Measurement Points: Bandwidth and Latency (>50 servers)
 - Every 10GE Hubs and 10GE site
 - 3 Equinix Locations (commercial peering locations)
 - Deploying 20+ more systems at low bandwidth sites in progress
- Full list of active services at:
 - <http://stats1.es.net/perfSONAR/directorySearch.html>
 - Instructions on using these services for network troubleshooting:
<http://fasterdata.es.net>

These services have proven extremely useful to help debug a number of problems

ESnet perfSONAR Measurement Infrastructure Usage



Regular tests between ESnet systems

- Latency - A full mesh of continuous tests between 25 systems
- Bandwidth:
 - All Nodes run 4 tests a day to Chicago, Sunnyvale, Houston & Washington

Other tests maintained by ESnet

- Regularly scheduled tests to Internet2, NLR & NOAA (JET)
- BNL, MIT, U-Penn, Indiana-U, LBL, SMU, Atlas Great Lakes T2

Some of the organizations running scheduled tests to ESnet

- PNL, ANL, LBL, USLHCnet, Hat Creek Radio Observatory, IHEP.AC.CN, lcg.ustc.edu.cn, UIUC, U-Utah, AARnet, U-Michigan, SMU, U-Penn, MIT

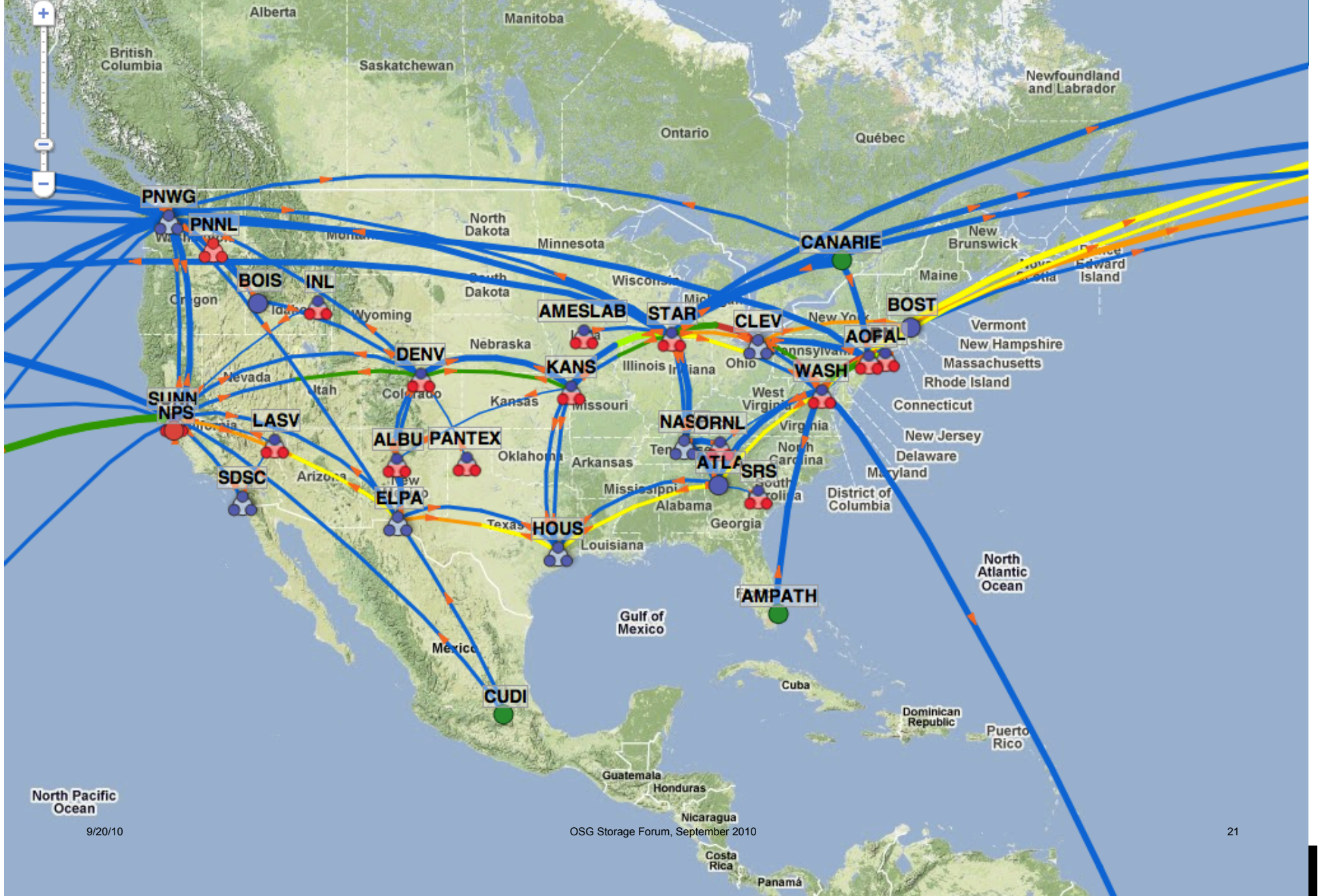

North Pacific Ocean

9/20/10

OSG Storage Forum, September 2010



Global PerfSONAR-PS Deployments

Based on “global lookup service” (gLS) registration, May 2010:
currently deployed in over 100 locations

- ~ 100 bwctl and owamp servers
- ~ 60 active probe measurement archives
- ~ 25 SNMP measurement archives
- Countries include: USA, Australia, Hong Kong, Argentina, Brazil, Uruguay, Guatemala, Japan, China, Canada, Netherlands, Switzerland

US Atlas Deployment

- Monitoring all “Tier 1 to Tier 2” connections

For current list of public services, see:

- <http://stats1.es.net/perfSONAR/directorySearch.html>

Sample Results: Finding/Fixing soft failures

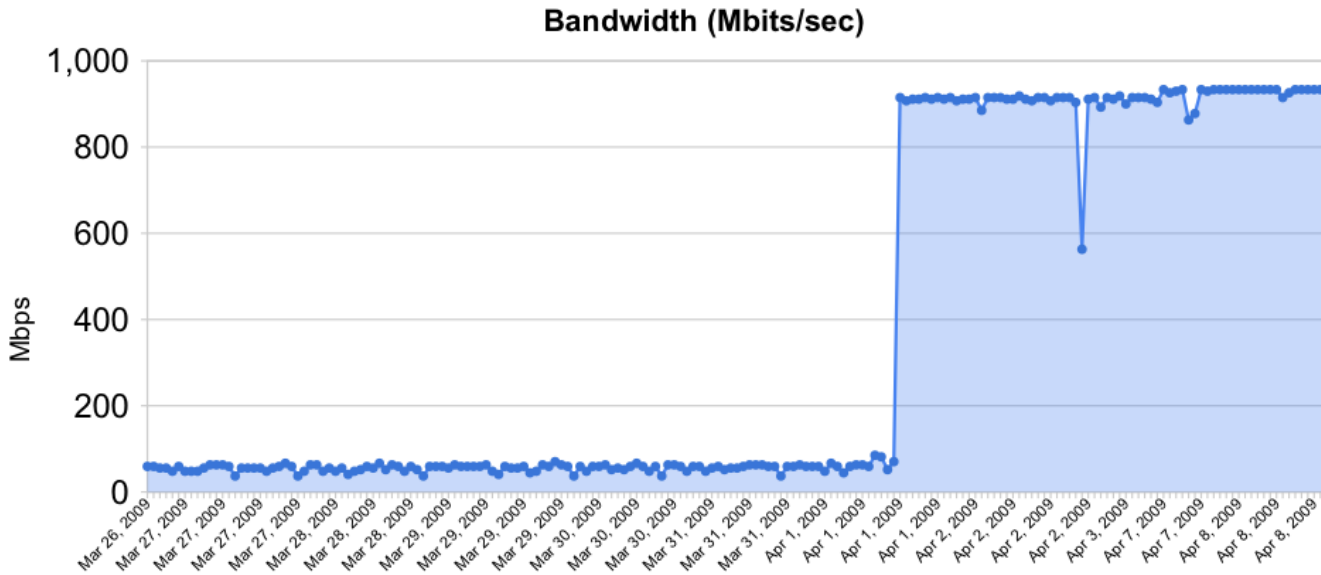

Rebooted router
with full route table

Gradual failure of
optical line card

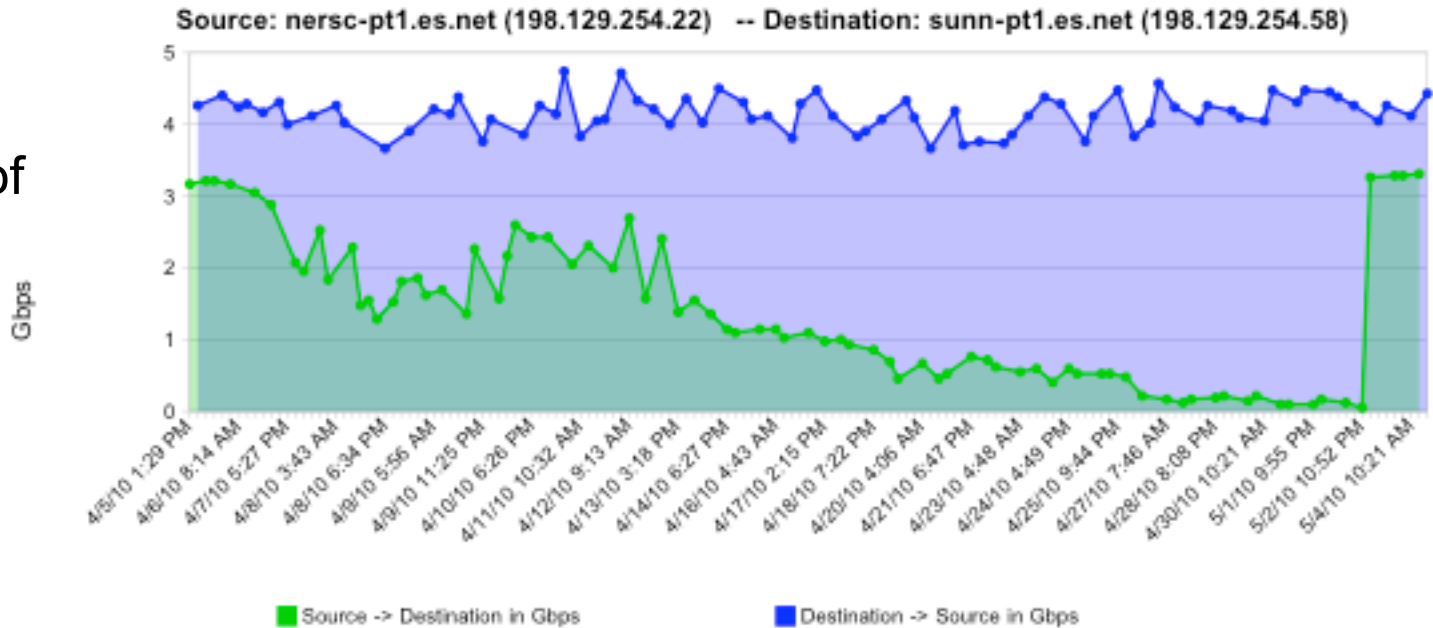

perfSONAR 3.2 release



Currently in beta testing (rc3)

New features

- RPM-based (Centos 5.5)

- New “Network Install” option alternative to LiveCD

- Many bug fixes / performance enhancements

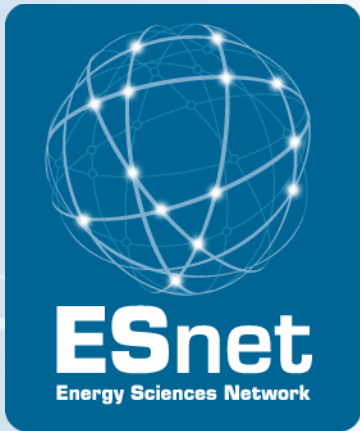

New ESnet performance Testing Service

New ESnet Diagnostic Tool: 10 Gbps IO Tester



16 disk raid array: capable of > 10 Gbps host to host, disk to disk

Runs anonymous read-only GridFTP

Accessible to anyone on any R&E network worldwide

1 deployed on now (lbl-diskpt1.es.net)

- 2 more (anl-diskpt1 and bnl-diskpt1) being deployed next week

Already used to debug many problems

Available for Supercomputing demo's

See: http://fasterdata.es.net/disk_pt.html

More Information



<http://100gbs.lbl.gov/>

<http://sites.google.com/a/lbl.gov/ani-testbed/>

<http://fasterdata.es.net/>

email: BLTierney@es.net

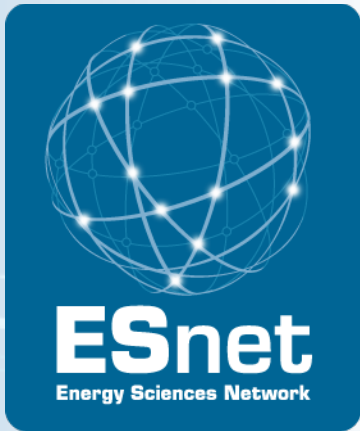

Extra Slides

Tabletop Testbed Configuration

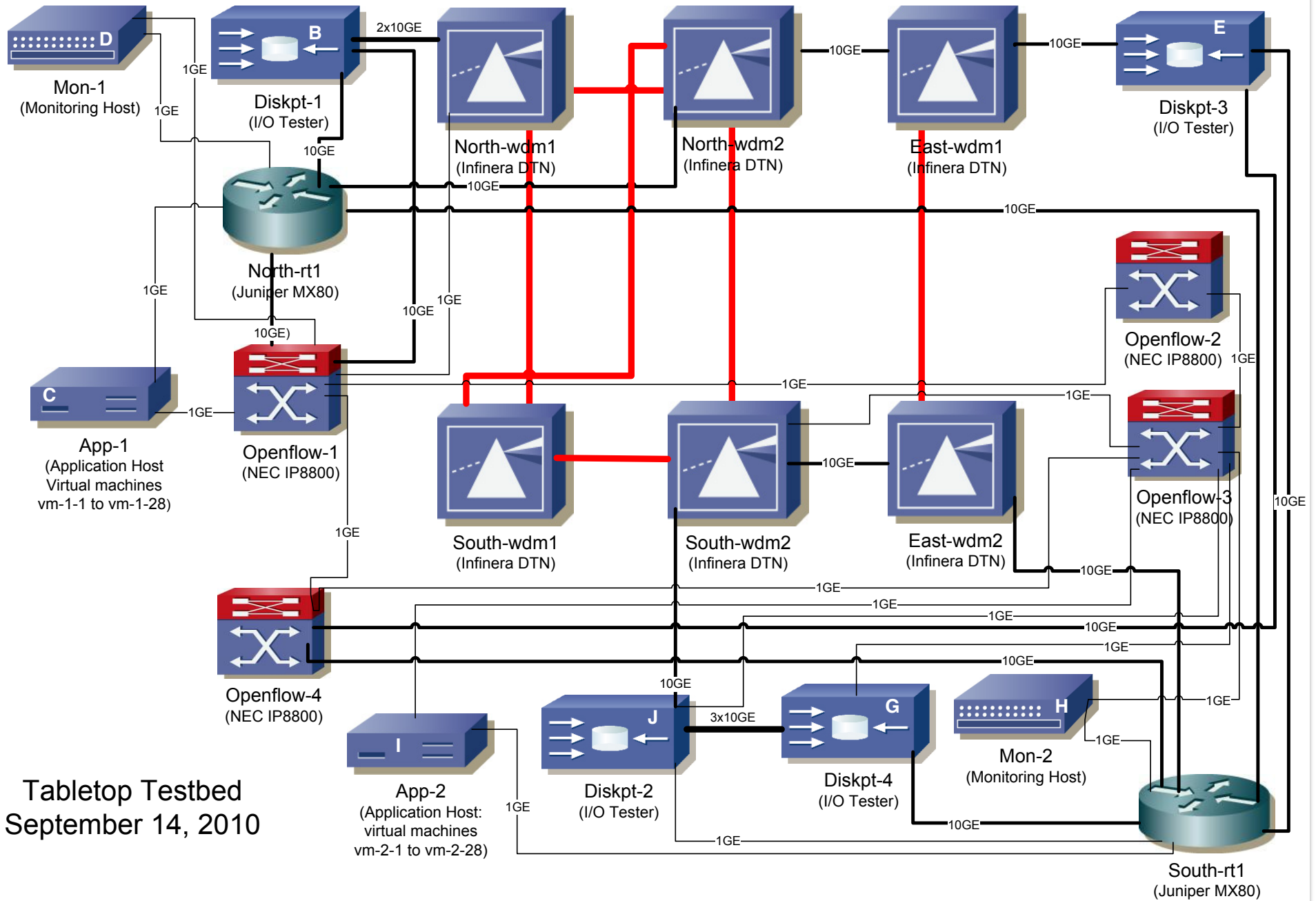

Tabletop Testbed
September 14, 2010

LIMAN ANI Testbed Configuration (40G aggregate)

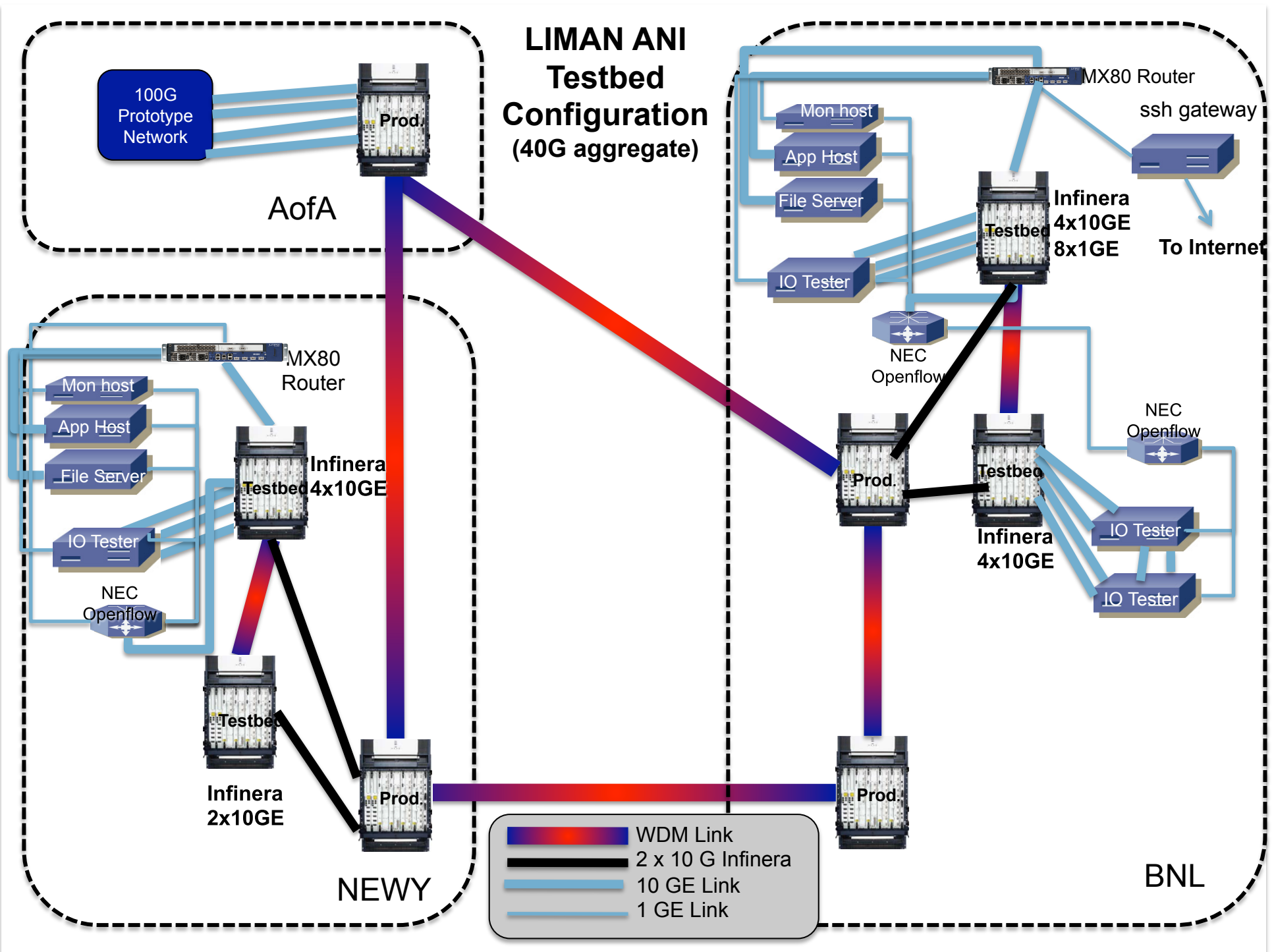

Sample PerfSONAR Site Deployment

