

REV	DESCRIPTION	DRAWN APPROVED DATE	DATE
	ER #9270; NEW RELEASE	D. ARNOLD	20-NOV-2008
A	ECO #9343; ITEM #5 UPDATED, ADDED *NOTE 9* & DIMENSIONS.	D. ARNOLD	09-FEB-2009
		L. RISTORI	16-FEB-2009
B	ECO #8712; ITEM 2 & NOTE 9 UPDATED; ADDED DIM & GEO TOL	D. ARNOLD	06-APR-2009
		L. RISTORI	08-MAY-2009
C	ECO #9500; ADDED ITEM 6 & WELD NOTE; ADDED *VIEW F-F*	D. ARNOLD	25-JUN-2009
		L. RISTORI	02-JUL-2009

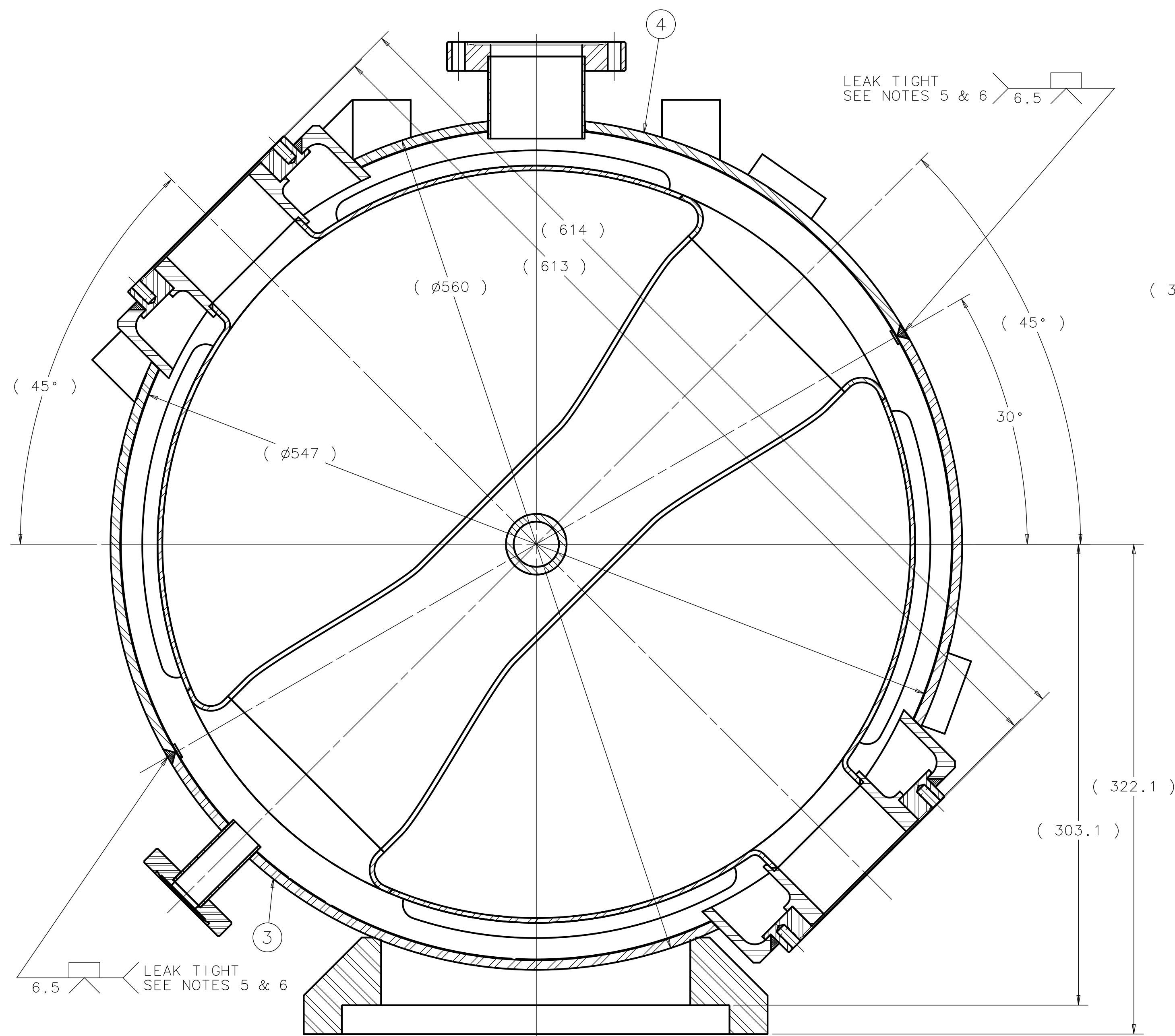

SECTION A-A
SCALE = 1:2

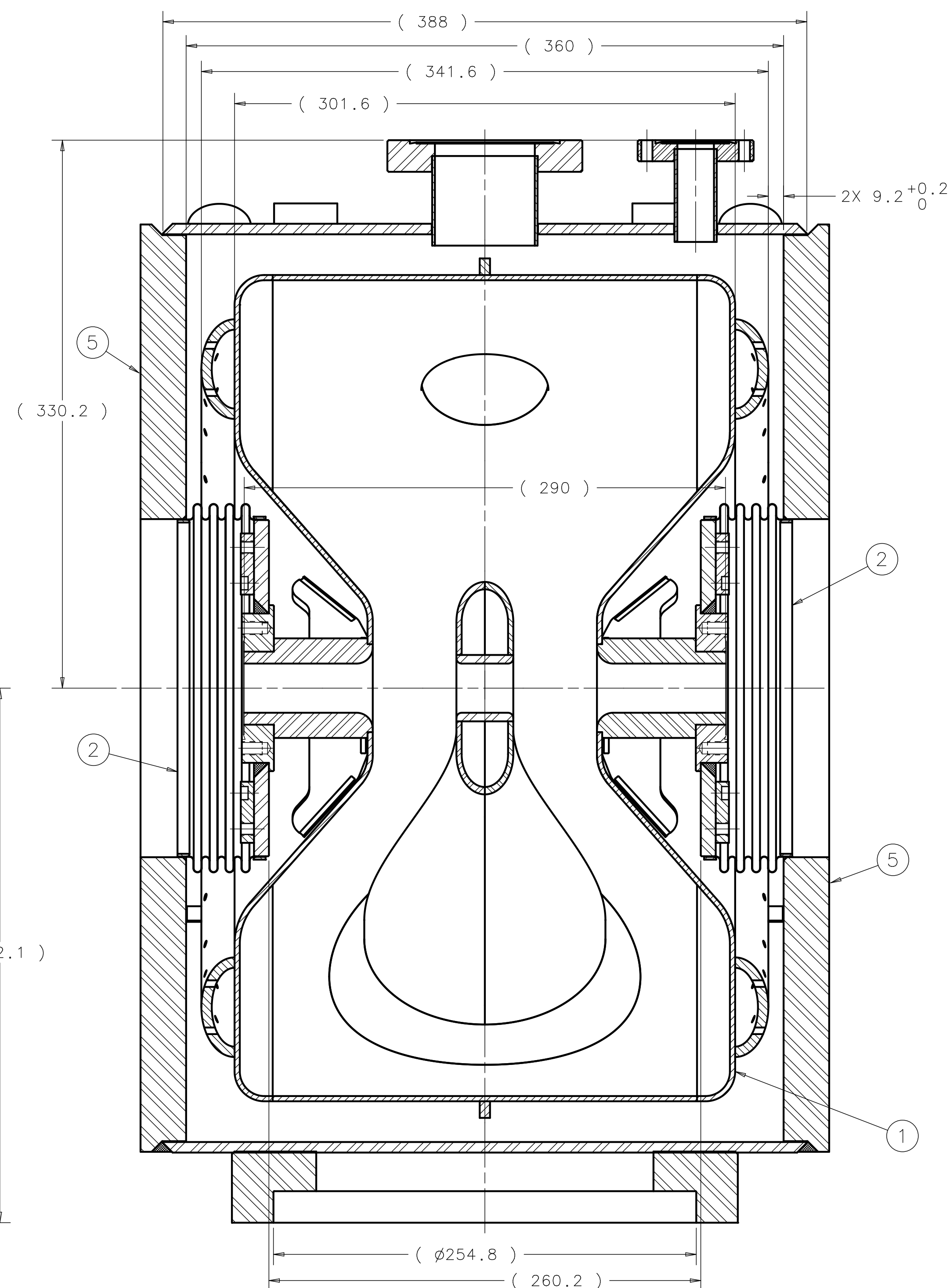

SECTION B-B
SCALE = 1:2

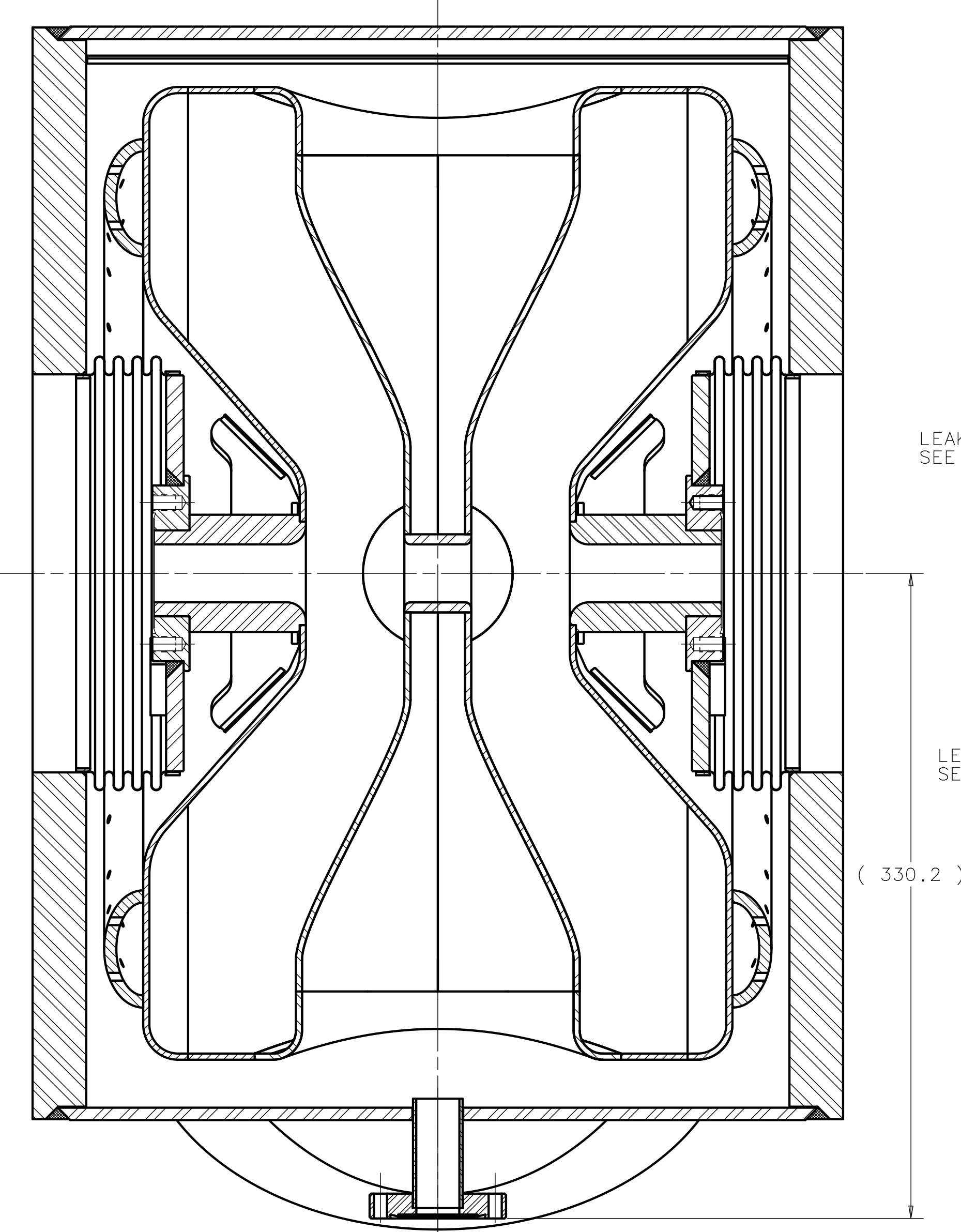
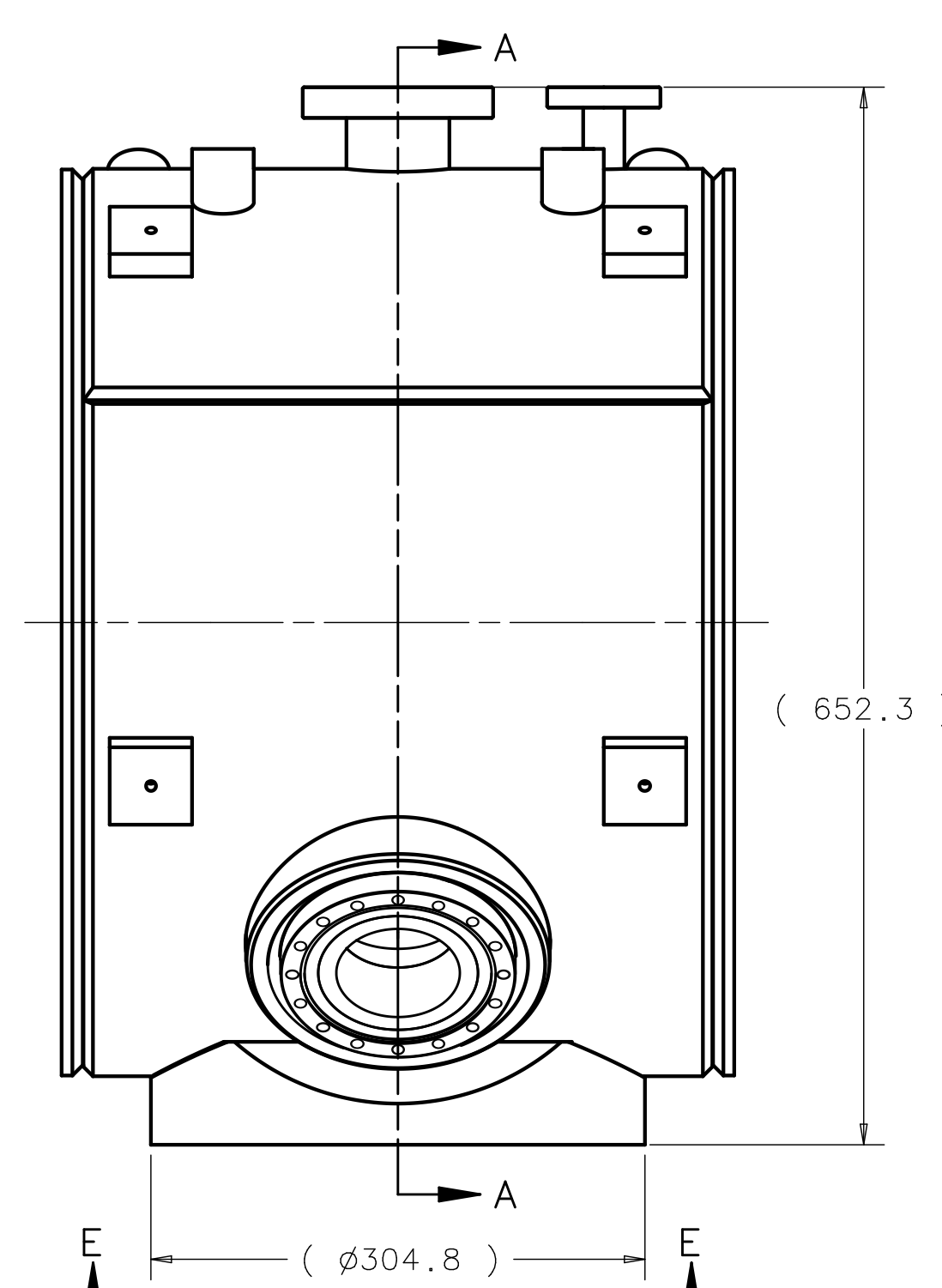
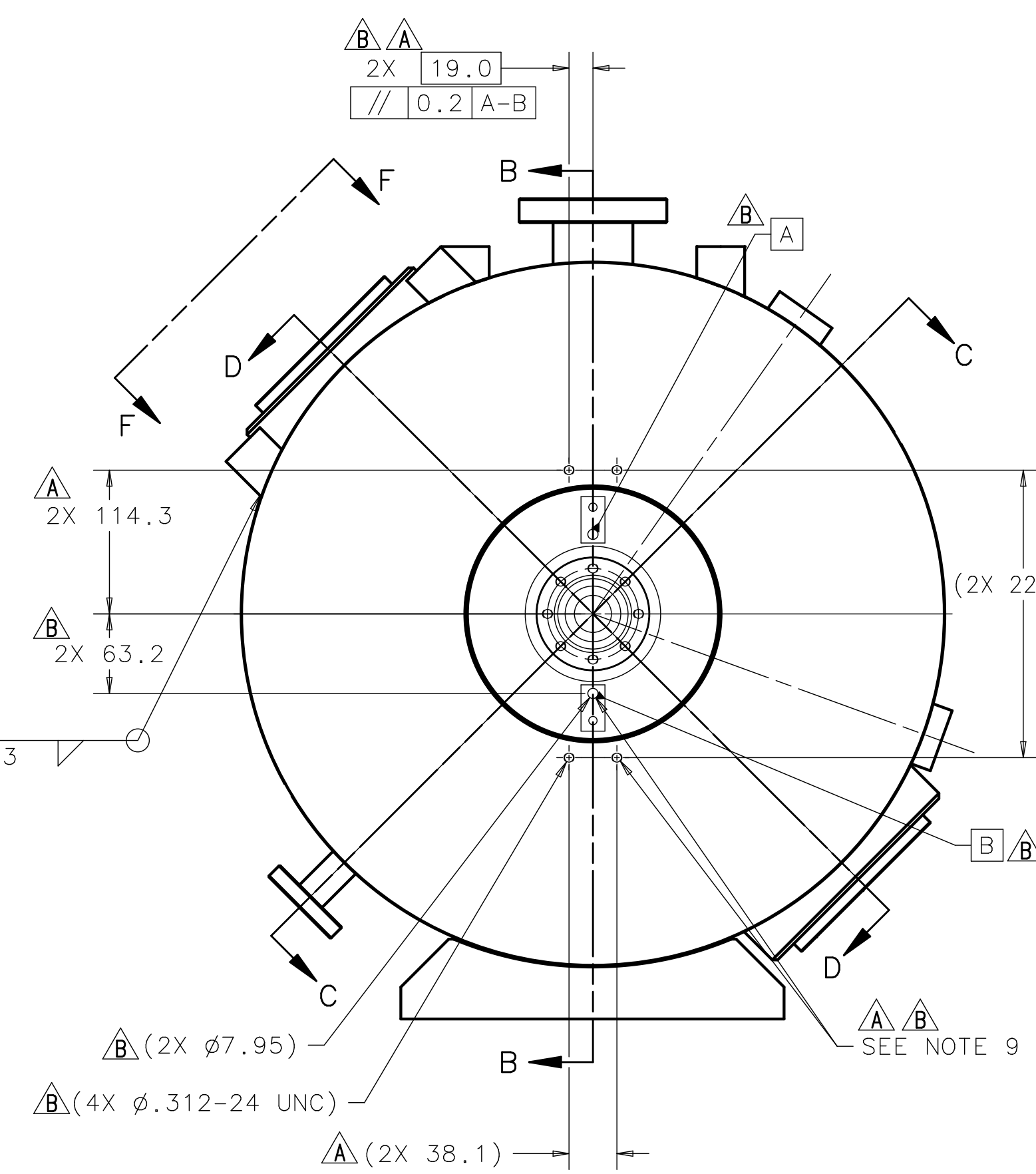
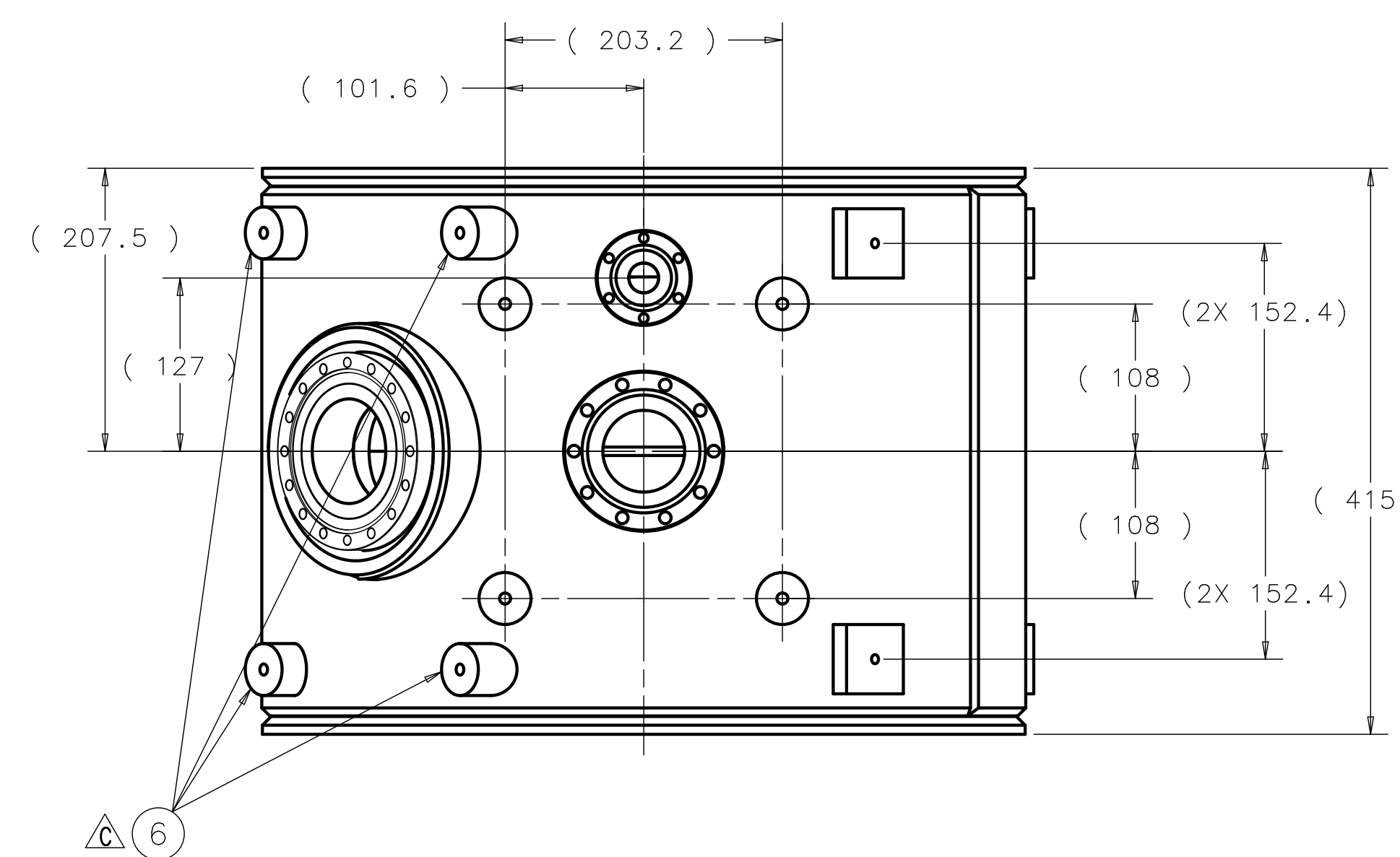

SECTION C-C
SCALE = 1:2

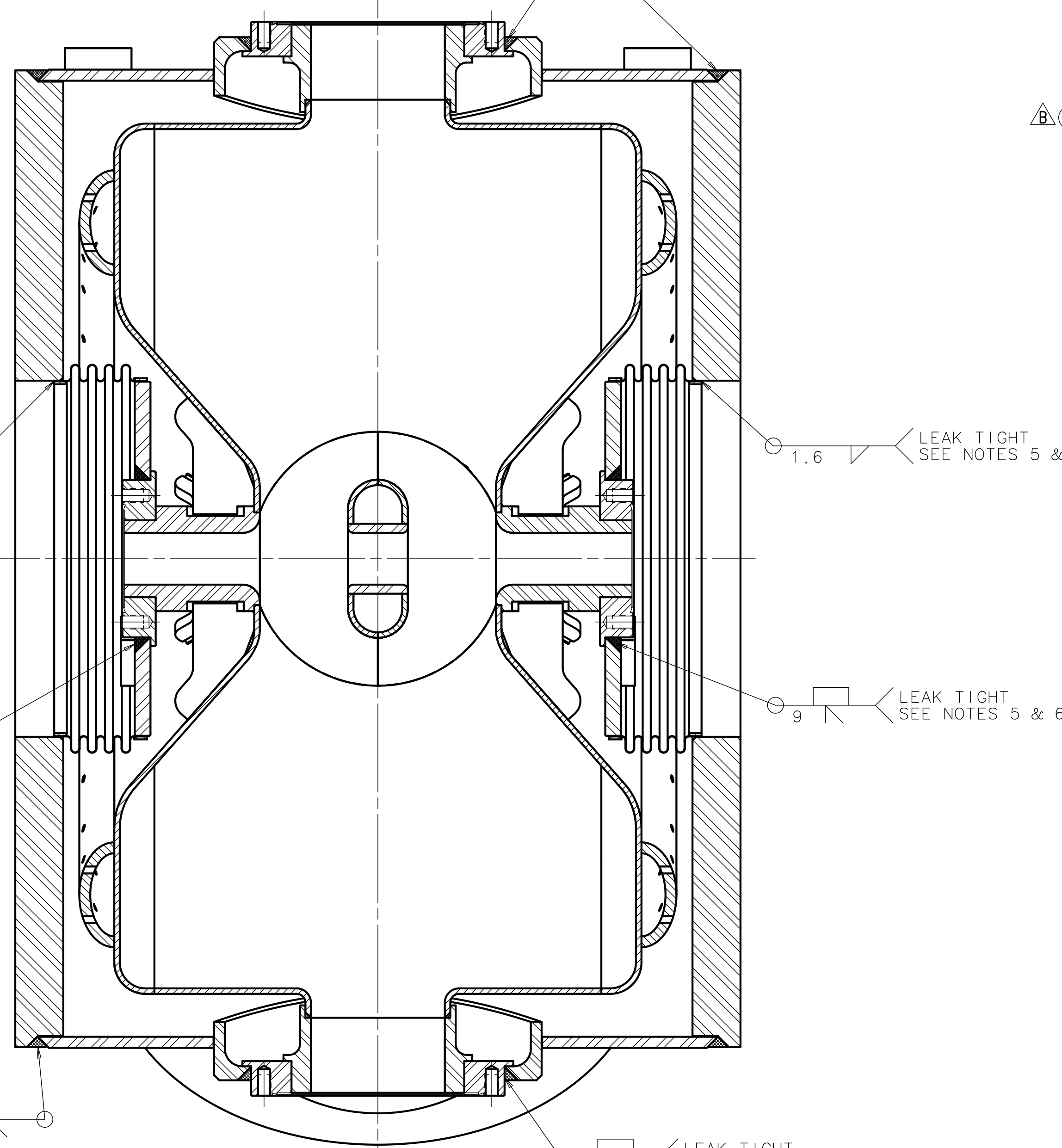

SECTION D-D
SCALE = 1:2

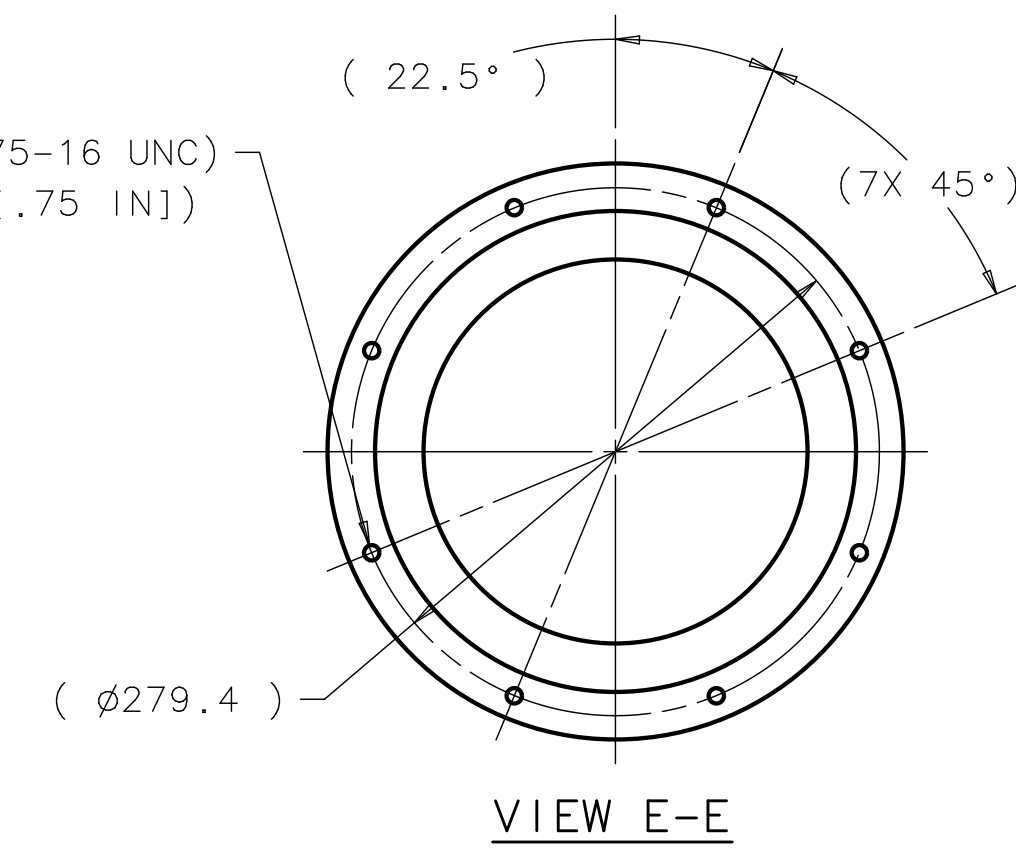
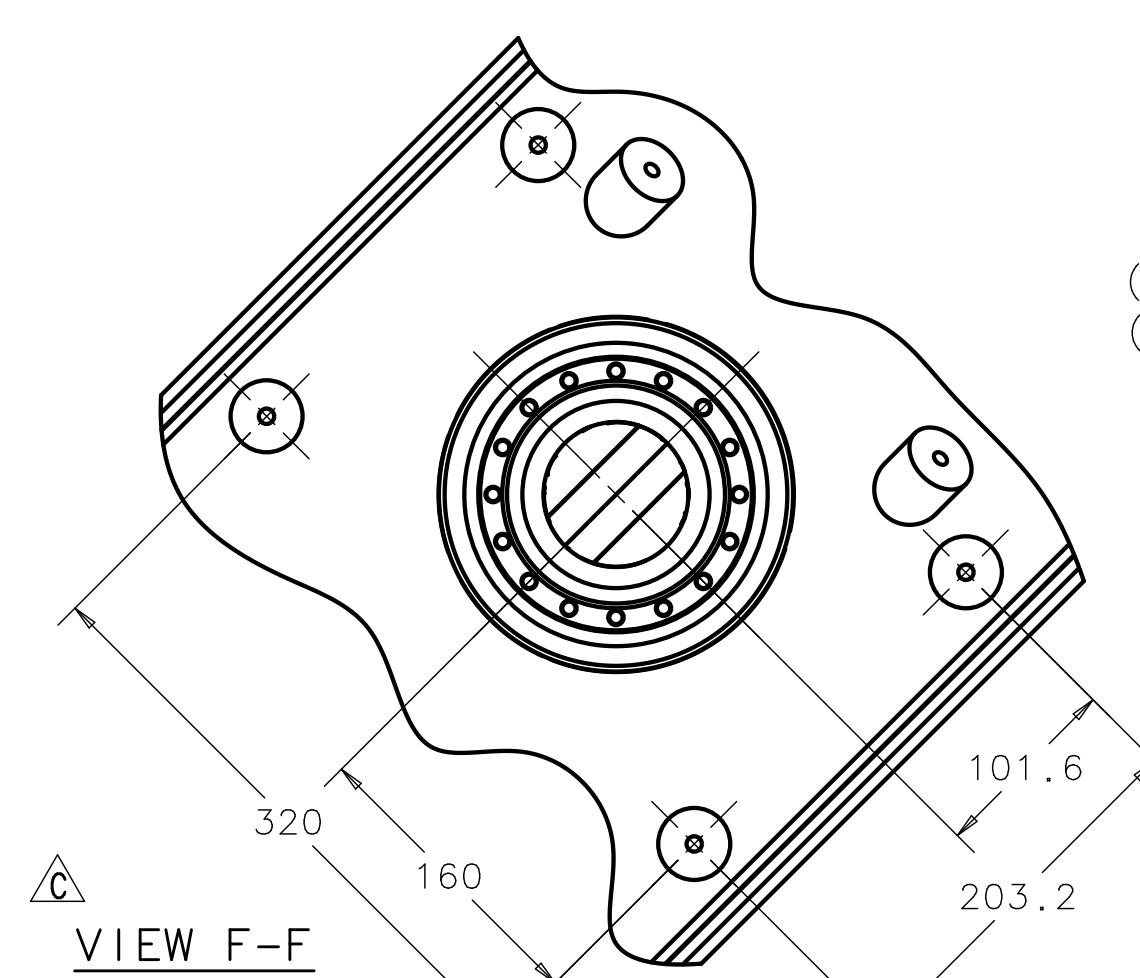

- NOTES (UNLESS OTHERWISE SPECIFIED):
- EST. WT. = 190 Kg. [420 LBS.]
 - DIMENSIONS APPLY AFTER ALL FINISHING.
 - DO NOT DAMAGE SEALING SURFACES AND KNIFE EDGES.
 - DO NOT DAMAGE INTERNAL SURFACES AND OPENINGS.
 - ALL FOUR(4) PORTS ARE TO BE BLANKED OFF.
 - REFERENCE FERMILAB SPECIFICATION ES-371029.
 - LEAK CHECK PER FERMILAB SPECIFICATION ES-107240.
 - REFERENCE DRAWING NUMBER 5520-MC-459047 FOR THE COMPLETE ASSEMBLY SCHEMATIC.
 - ORIENTATION OF HOLES OF ITEM #2 AND ITEM #5 DURING FINAL ASSEMBLY IS AS SHOWN. THIS ORIENTATION IS REQUIRED ON BOTH SIDES.

ITEM	PART NO.	DESCRIPTION OR SIZE	QTY.
6	MA-458970	SHELL HANDLING BOSS	4
5	MC-459387	BASE PLATE - MACHINED	2
4	MD-458844	SHELL OUTPUT HALF ASSEMBLY	1
3	MD-458846	SHELL INPUT HALF ASSEMBLY	1
2	MC-459374	INNER END WALL BELLOW ASSY	2
1	ME-458827	SSR1 SINGLE SPOKE RESONATOR	1

PARTS LIST			
UNLESS OTHERWISE SPECIFIED	ORIGINATOR	L. RISTORI	08-JUL-2008
X	O. X	DRAWN	D. ARNOLD 20-NOV-2008
± 0.5 ± 0.2 ± 0.5*	CHECKED	C. M. GRIMM	08-DEC-2008
APPROVED	L. RISTORI		23-DEC-2008
USED ON			
SSR1 PROTOTYPE TUNER ASSEMBLY			
MATERIAL			
SEE PARTS LIST			

NOTICE: IMAGE OBTAINED FROM FERMILAB WEB SITE. This information is provided for REFERENCE use only. Not for MANUFACTURE, or DESIGN INFORMATION. All information contained in this document represents work sponsored by an agency of the U.S. Government. Neither the U.S. Government nor any agency thereof, nor Universities Research Association, Inc., nor any of their employees or officers, makes any warranty, express or implied, or assumes any legal liability or responsibility for the accuracy, completeness, or usefulness of any information, apparatus, product, or process disclosed, or represents that its use would not infringe privately owned rights.

FERMILAB NATIONAL ACCELERATOR LABORATORY
 UNITED STATES DEPARTMENT OF ENERGY

HINS - FRONT END
SSR1 PROTOTYPE TUNER ASSEMBLY
HELIUM VESSEL ASSEMBLY WELDMENT

SCALE	DRAWING NUMBER	SHEET	REV
1:4 & NOTED	5520.000-ME-458850	1 OF 1	C

CREATED WITH: Ideas12NXSeries | GROUP: TD/DCIS-DESIGN-COMPUTING