

DESCRIPTION: PIPING SPOOL, ROLLING OFFSET, LEFT HAND  
 PROJECT: PIP-11\_CMTF  
 CATEGORY: PIPE

REV	REVISION CONTROL DOCUMENT	DATES	SIGNATURES	
-	F10136953---RCD		DRAWN	
			APPROVED	

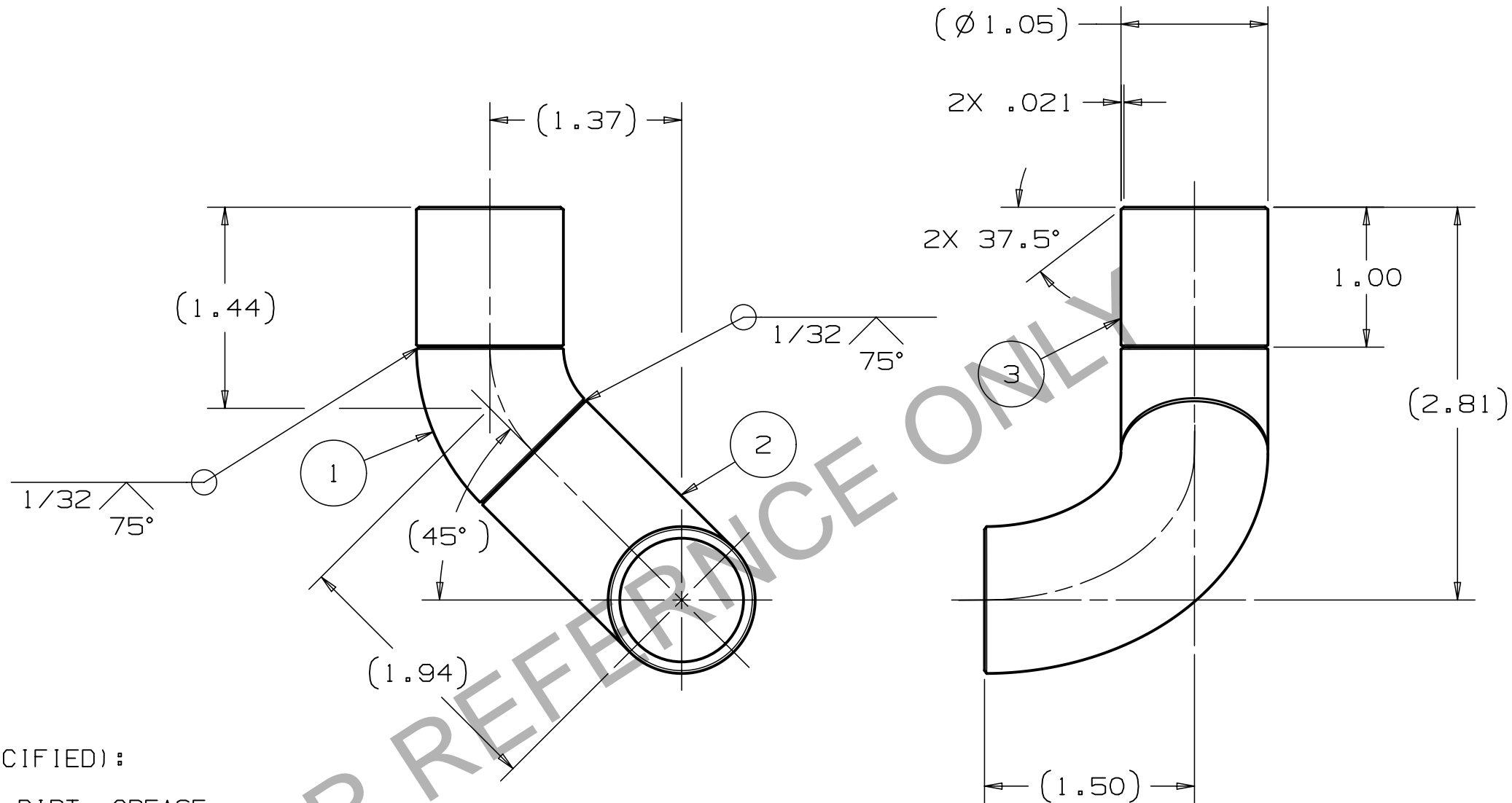

NOTES (UNLESS OTHERWISE SPECIFIED):

- ASSEMBLY MUST BE FREE OF DIRT, GREASE, OIL AND CHIPS.
- ASSEMBLY TO BE FREE OF ALL SHARP EDGES, CORNERS, AND BURRS.
- ALL WELDS TO BE VACUUM LEAK TIGHT. LEAK TEST: NO LEAK SHALL BE DETECTABLE ON THE MOST SENSITIVE SCALE OF A HELIUM LEAK DETECTOR WITH A MINIMUM SENSITIVITY OF 10<sup>-9</sup> ATM. CC/SEC.
- WELDS TO COMPLY WITH MOST RECENT VERSION OF PROCESS PIPING CODE ASME B31.3 FOR NORMAL FLUID SERVICE. GROOVE WELDS TO BE COMPLETE PENETRATION. RELATED DOCUMENTATION OF MATERIALS, WELDING, AND IN-PROCESS INSPECTION MUST BE INCLUDED WITH THE FINAL PRODUCT DELIVERY.

ITEM	FERMI #	PART NAME	QTY
3	FC0073288	PIPE, 3/4" SCH.10 304 SS	1
2	FC0045569	ELBOW, PIPE-90, LONG, 3/4"x 10S, 304 SS	1
1	FC0028692	ELBOW, PIPE, 45 DEG, 3/4"x10S, 304 SS	1

PARTS LIST

UNLESS OTHERWISE SPECIFIED					DRAWN	C.REID	DATE	27-Mar-2020	<p><b>FERMI NATIONAL ACCELERATOR LABORATORY</b> UNITED STATES DEPARTMENT OF ENERGY</p>				
±.X	±.XX	±.XXX	±X/X	±X°	CHECKED		DATE						
.1	.02	.005	1/16	2.5°	APPROVED		DATE						
BREAK ALL SHARP EDGES, MAX: .015 DO NOT SCALE DRAWING DIMENSIONS BASED ON: ASME Y14.5-2009 MAX MACHINE ALL SURFACES: 125√ DRAWING UNITS: INCHES					USED ON				NAME				
<p>THIRD ANGLE PROJECTION</p>					F10133778				PIPING SPOOL, ROLLING OFFSET, LEFT HAND				
					MATERIAL				SCALE	SIZE	DRAWING NUMBER	SHEET	REV
					SEE PARTS LIST				1:1	B	F10136953	1 of 1	-
					GROUP: Technical Division - Design and Drafting				CAGE CODE: OUSR6				

TEMPLATE VERSION: 2018.12.03