



QXFA Series Coil Production Specification

US-HiLumi-doc-2986
Date: 6/9/20
Page 1 of 26



US HL-LHC Accelerator Upgrade Project

QXFA Series Coil Production Specification

Prepared by:

Miao Yu, US HL-LHC AUP 302.2.04 Manager, FNAL
Jesse Schmalzle, US HL-LHC AUP 302.2.06 Manager, BNL
Fred Nobrega, US HL-LHC AUP 302.2.05 Manager, FNAL

Reviewed by:

James Blowers, US HL-LHC AUP Quality Assurance Manager, FNAL
Giorgio Ambrosio, US HL-LHC AUP Magnets L2 Manager, FNAL

Approved by:

Miao Yu, US HL-LHC AUP 302.2.04 Manager, FNAL
Jesse Schmalzle, US HL-LHC AUP 302.2.06 Manager, BNL
Fred Nobrega, US HL-LHC AUP 302.2.05 Manager, FNAL
Soren Prestemon, US HL-LHC AUP 302.2.07 Manager, LBNL
James Blowers, US HL-LHC AUP Quality Assurance Manager, FNAL
Giorgio Ambrosio, US HL-LHC AUP Magnets L2 Manager, FNAL
Ruben Carcagno, US HL-LHC AUP Deputy Project Manager, FNAL
Giorgio Apollinari, US HL-LHC AUP Project Manager, FNAL



QXFA Series Coil Production Specification

US-HiLumi-doc-2986

Date: 6/9/20

Page 2 of 26

Revision History

Revision	Date	Section No.	Revision Description
	4/22/20	all	Initial release
	4/28/20	1.1	Added "profile" in Table 1.1 and added note about tolerances in text.
	5/11/20	4	In bullet "Before step 3 the temperature of the thermocouples set on the reaction fixture shall never exceed ..." changed from "218°C" to "217°C". In bullet "The temperature of all thermocouples set on the reaction fixture shall be within +/- 7 °C ..." changed from "400 °C" to "395 °C". In Table 4.1 steps 3, 4 and 5 changed from "400 °C" to "395 °C".
	5/14/20	1.1	In Table 1.1 added line "Inner radius profile at pole 74.750 + 0.0 - 0.250"
	6/9/20	2.7	In Table 2.7 Changed the dowel pin material from "SS316" to "Ti-6Al4V" and the drawing ID from "FC0050264" to "F10133226"



QXFA Series Coil Production Specification

US-HiLumi-doc-2986
Date: 6/9/20
Page 3 of 26

Contents

Scope	5
1 Coil Design and Fabrication Steps	5
1.1 Coil design.....	5
1.2 Fabrication Steps	7
1.3 Coil QA/QC.....	7
2 QXFA Coil Fabrication Components	8
2.1 Nb ₃ Sn Cable	8
2.2 Poles	8
2.3 End Parts.....	10
2.4 Wedges	11
2.5 Quench Heater Trace	12
2.6 NbTi Cable Lead	13
2.7 Other Materials.....	15
3 QXFA Coil Fabrication Specification: Winding and Curing	17
4 QXFA Coil Fabrication Specification: Heat Treatment	19
5 QXFA Coil Fabrication Specification: Epoxy Impregnation	21
5.1 Epoxy Mixing and Degassing	21
5.2 Coil Degassing	21
5.3 Resin Transfer	21
5.4 Cure Cycle.....	22
5.5 Quality Control.....	22
6 QXFA Coil Fabrication Specification: Instrumentation.....	23
7 Final Coil QC and Shipment	25
8 Coil Handling and Shipment Requirements	25
References	26

Scope

The purpose of this document is to define the specifications for the fabrication of QXFA series coils to be used in MQXFA quadrupole magnets [1] by the US High-Luminosity LHC Accelerator Upgrade Project (AUP). Coils fabricated according to these specifications are expected to allow MQXFA magnets to meet the MQXFA Functional Requirements Specification [2]. These specifications for the fabrication of QXFA series coils are based on the R&D performed by the US LHC Accelerator Research Program (LARP) and the development performed by AUP [3], in collaboration with CERN, through fabrication and test of pre-series coils and magnets.

1 Coil Design and Fabrication Steps

1.1 Coil design

The QXFA coil has a magnetic length of 4.2 m at the magnet operating temperature and is 4.529 m long (not including the NbTi current lead length) at room temperature, see Figure 1.1. It consists of Nb₃Sn cable (in grey), plasma coated stainless steel end parts (in red), copper wedges (in orange), titanium pole pieces (in blue), fiberglass insulation etc., all encapsulated by epoxy. Tooling used for coil fabrication use numbered laminated pieces that are assembled in the same order for each coil fabrication process step. Coil parts and tooling are made to defined tolerances and inspected by QC inspectors.

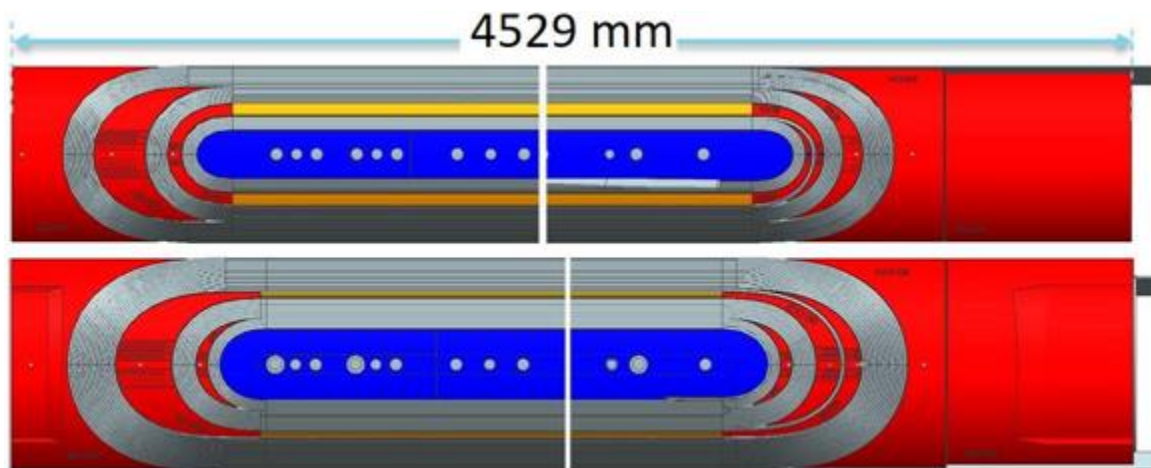

Figure 1.1 QXFA Coil inner layer (top) and outer layer (bottom)

The QXFA coil is a two-layer $\cos-2\theta$ coil without interlayer splice and with saddle-shaped ends. The coil cross-section is shown in Figure 1.2. In the inner layer the first conductor group has 5 turns and the second conductor group has 17 turns. The inner layer wedge separates the two conductor groups on both coil sides. In the outer layer the first conductor group has 12 turns and the second conductor group has 16 turns. The outer layer wedge separates the two conductor groups on both coil sides.

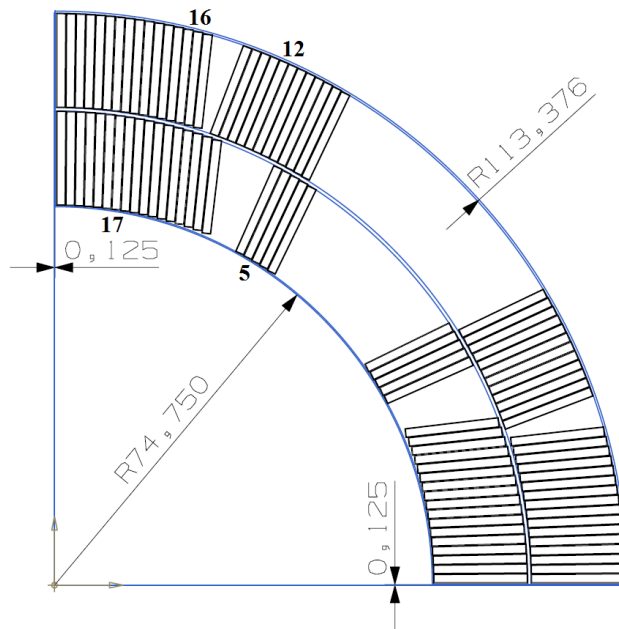

Figure 1.2 Coil Cross-section

Table 1.1 lists the final coil dimensional specification at room temperature (drawing F10115848). It should be noted that positive tolerances specify excessive material and negative tolerances specify less-than-nominal material. The coil design is presented in sections 4.1 and 4.2 of MQXFA Final Design Report [1]. The coil design was reviewed and approved in May 2018 [4].

Table 1.1 Coil Dimensional Specification (see text for note about tolerances)

	Dimension (mm)	Tolerance (mm)
Inner radius profile at pole	74.750	+ 0.0, - 0.250
Inner radius profile except pole	74.750	+ 0.150, - 0.250
Outer radius profile	113.376	+ 0.200, - 0.250
Coil to midplane gap	0.125	+ 0.075, - 0.125
Coil length	4529.0	± 5.0
Pole Keyway azimuthal position	Centered with respect to midplanes	± 0.25

1.2 Fabrication Steps

QXFA coils are fabricated at Brookhaven National Laboratory (BNL) and at Fermi National Accelerator Laboratory (FNAL) using the same drawings, these specifications, and following the same fabrication steps. Coil fabrication includes three major steps, and two sets of drawings are associated with the coil fabrication, QXFA Coil Assembly_WCR (F10115641) and QXFA Coil Assembly_Impregnation (F10115848). Detailed fabrication steps are described in travelers under version control at each coil fabrication laboratory.

1. Winding and Curing

The two-layer coil is wound continuously, without a splice at transition between the inner and outer layers using the double-pancake technique. After the inner layer coil is wound, the coil is painted with binder, put into the curing mold and cured at 150 °C. The inter-layer insulation is set on the outer surface of the inner layer coil. Subsequently, the outer layer coil is wound using the inner layer coil as the winding mandrel. After the outer layer coil is wound it is painted with binder. Finally, the whole coil (consisting of inner and outer layer) is set into the curing mold and cured at 150 °C.

2. Reaction

The cured coil is assembled into the reaction fixture and heat treated in the reaction oven under the Argon atmosphere, where the Tin reacts with the Niobium to form the brittle, superconducting Nb₃Sn compound.

3. Impregnation

Flexible NbTi leads are spliced to the short Nb₃Sn leads, which are protected by the saddle extension. The quench protection heater circuits are installed on the coil outer surface. The brittle reacted coil is set into the impregnation fixture and vacuum impregnated with epoxy.

1.3 Coil QA/QC

The coil QA/QC plan consists of electrical measurements, dimensional measurements and inspections made throughout the fabrication process.

Electrical continuity checks between coil and ground, and between coil and coil parts are performed during coil winding and curing, and during coil reaction. Electrical continuity checks between coil and quench heaters are performed after coil impregnation. When the coil is transferred to the shipping fixture, coil resistance, inductance and quality factor are measured. Hipot tests and impulse tests are also performed when coil fabrication is complete before shipment. The criteria for MQXFA electrical tests are in the Electrical Design Criteria [5]. Specifications for all coil electrical tests with acceptance ranges are in QXFA Coil Fabrication Electrical QA [6].

The coil QA/QC plan includes also mechanical measurements made throughout the fabrication process. The pole segment gaps, as well as the coil end conductor group locations, are measured at each fabrication stage. After impregnation, the coil profile is measured at 14 cross sections with a coordinate measuring machine (CMM) [7]. The CMM profile measurement locations are shown in a dedicated drawing [8].

Final QC steps after coil fabrication is complete and acceptance process are described in Chapter 7.

2 QXFA Coil Fabrication Components

The coil fabrication components are provided by FNAL to the coil fabrication teams at both BNL and FNAL, with the part kit for each coil attached to its traveler. This section describes the major components, including cable, poles, end parts, wedges, quench heater protection trace, coil insulation materials and other materials. The list of all the components provided to BNL is documented in Interface Control Document (ICD) WBS 302.2.04-06 [9], and the list of all the components provided to FNAL is documented in ICD WBS 302.2.04-05 [10]. The inspection of the components, excluded cable, is described in the QC Plan for QXFA Coil Parts [11].

2.1 Nb₃Sn Cable

The Nb₃Sn cable for QXFA coil is fabricated at Lawrence Berkeley National Lab (LBNL) according to the cable fabrication specification, US-HiLumi-doc-74. The bare cable is insulated at outside vendor with the insulation thickness of 0.145 ± 0.005 mm according to the HL-LHC AUP specification, US-HiLumi-doc-75.

The cable is identified using the scheme of P43OLxxxx, US-HiLumi-doc-41, where “xxxx” is the cable series number starting from 1095 for the project. The approved spool of cable with the unique ID is assigned to fabricate a coil in the AUP Coil Interface Traveler [12]. The witness samples, in the form of extracted strands from the cable used and round wires from the reference spool [13], are prepared for heat treatment by the strand team at FNAL. These witness samples are used to validate the coil reaction cycle and are distributed together with the assigned insulated cable spool to either BNL or FNAL coil fabrication team.

2.2 Poles

The QXFA coil is wound around the pole parts, and there are 1 piece of lead end pole, 9 pieces of center pole and 1 piece of return end pole for both the inner and the outer layer coil, as shown in Figure 2.1 The pole parts are made of Ti-6Al4V STA (solution treated aging process) to have better straightness along the length. Table 2.1 lists the part name and the drawing ID for the poles, which is laser stamped on the ID surface of each pole part.

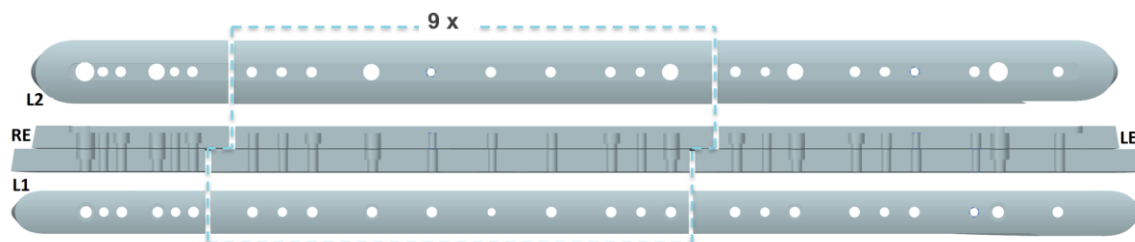
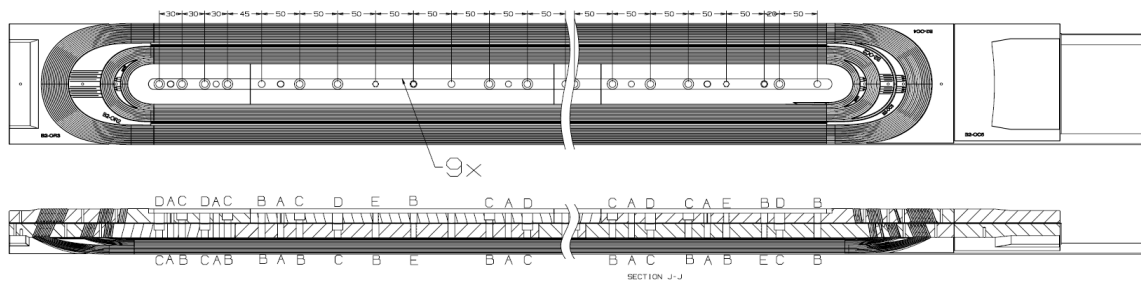

Figure 2.1 QXFA Coil Pole Set

Table 2.1 QXFA Coil Pole Components; L1 is the inner layer, and L2 is the outer layer.

Name	Drawing ID	Qty. per coil
Pole, Lead End L1	F10039540	1
Pole, Layer 1	F10039545	9
Pole, Return End L1	F10005738	1
Pole, Lead End L2	F10039541	1
Pole, Layer 2	F10039546	9
Pole, Return End L2	F10005750	1

In the coil, cooling channels with minimum 8 mm diameter and 50 mm spacing are required to allow for heat extraction from the coil aperture to the heat exchangers set in the yoke. These cooling channels are designed on each pole: holes B, C, D and E in Figure 2.2. The poles are bolted to the winding anchor bars through clearances holes B, C and D, and the screws are removed after coil winding and curing. The impregnated coil is lifted through the lifting holes E. Hole A is an 8.02 mm (+0.02 mm, -0) pin hole. Each L1 (inner layer) pole part is positioned on the winding mandrel with two tooling pins, and each pair of inner and outer layer pole parts are aligned with two non-magnetic dowel pins. Tooling pins are removed after coil curing, while dowel pins remain and are impregnated in the coil.



Pin Hole A: $\varnothing 8.02\text{mm}$ for 8 mm dowel pin
 Clearance Hole B: $\varnothing 9\text{mm}$ thru for 5/16" or M8x1.25 SHCS
 Clearance Hole C: $\varnothing 9\text{mm}$ thru, L $\varnothing 13.8\text{mm}$ $\varnothing 8.8\text{mm}$ for 5/16" or M8x1.25 SHCS
 Clearance Hole D: $\varnothing 13.8\text{mm}$ thru for 5/16" or M8x1.25 SHCS
 Lifting Hole E: M8x1.25 threaded
 After coil fabrication, hole B, C, D and E will be used as cooling channel for the magnet

Figure 2.2: Cooling channels through coil poles

The pole part has the 3D profile tolerance 0.050 mm or ± 0.025 mm as shown in Figure 2.3., including the keyway which is designed on each L2 (outer layer) pole to align the coil to the tooling during coil fabrication and to align the coil to the surrounding structure during magnet assembly. The length tolerance of each pole segment is ± 0.12 mm.

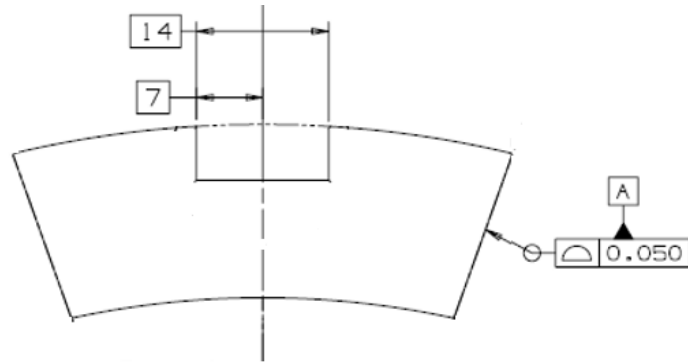

Figure 2.3 Keyway Profile Tolerance

2.3 End Parts

End parts including spacers, saddles and splice blocks are made of SS 316L, which contains less magnetic material components among the stainless-steel series, and the cobalt content shall be no higher than 0.357%. Figure 2.4 shows the models of 16 different end parts.

The spacers and saddles are designed based on the nominal coil size after reaction. During winding, the coil is not fully constrained, and the cable tries to separate from radial surface of the mandrel (springback) especially at the ends, causing the shape of the turn not to match the shape of the end parts, which makes it very difficult to install them. Therefore, flexible features (slits) have been introduced in spacers (except the inner layer lead end 1st spacer) and saddles. End parts are plasma coated with $200\ \mu\text{m} \pm 50\ \mu\text{m}$ thick Al_2O_3 to increase the dielectric strength between the end parts and the coil. The thin layer of the plasma coating is fragile, especially in combination with the slits on these parts. Specific procedures have been developed for the disposition of Non-Conforming Plasma Coated End Parts and are documented in [14].

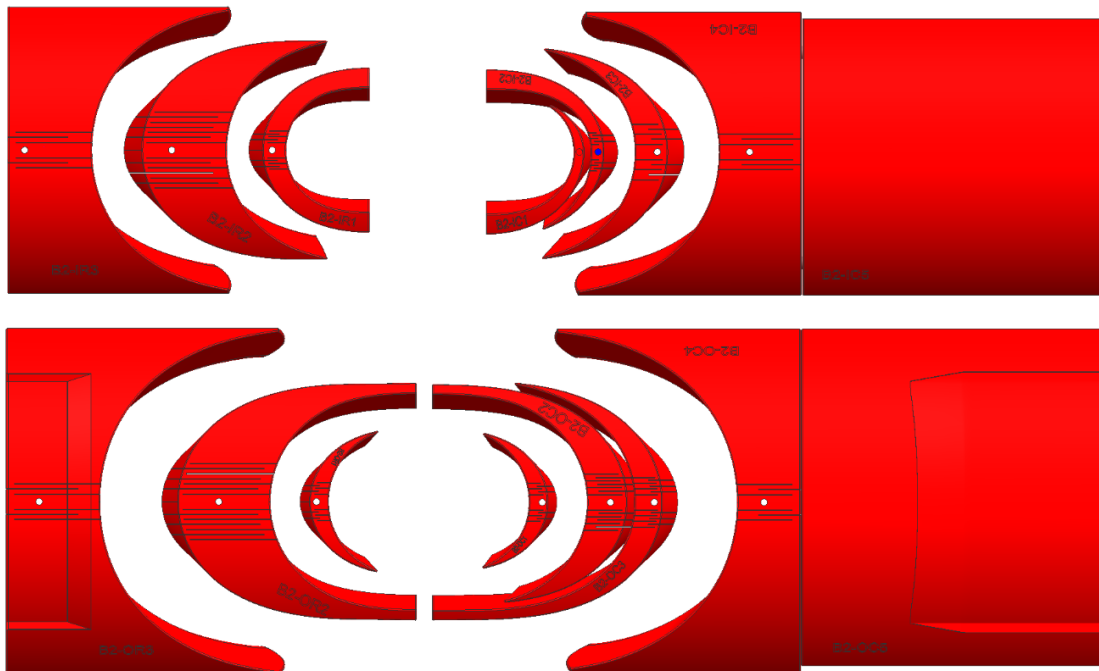

Figure 2.4 QXFA Coil End Parts for L1 (top) and L2 (bottom)



QXFA Series Coil Production Specification

US-HiLumi-doc-2986

Date: 6/9/20

Page 11 of 26

Table 2.2 lists all end parts with the drawings at each fabrication step. The identification number format is Bx-xxx, where B represents BEND [15], the first “x” represents the design generation (the latest design generation is 2), the second “x” shall be either I (inner layer) or O (outer layers), the third “x” shall be either R (return end) or C (lead end), and the fourth “x” represents end part’s number. For example, 2nd generation design, inner layer LE spacer 2, the identification number is B2-IC2. The identification number is engraved on the surface of the part with 3 mm depth, and it is still visible after coating.

Table 2.2 QXFA Coil End Parts

Name	ID #	Drawing for Solid Part	Drawing for Part with slits	Drawing for Part with Plasma coating
Spacer 1, Lead End L1	B2-IC1	F10039749	-	F10088257
Spacer 2, Lead End L1	B2-IC2	F10039750	F10041400	F10042026
Spacer 3, Lead End L1	B2-IC3	F10039751	F10041401	F10042027
Saddle, Lead End L1	B2-IC4	F10039752	F10041397	F10042022
Splice block, Lead End L1	B2-IC5	F10039892	-	F10042599
Spacer 1, Return End L1	B2-IR1	F10039746	F10041413	F10042035
Spacer 2, Return End L1	B2-IR2	F10039747	F10041414	F10042036
Saddle, Return End L1	B2-IR3	F10039748	F10041415	F10042037
Spacer 1, Lead End L2	B2-OC1	F10039756	F10041409	F10042032
Spacer 2, Lead End L2	B2-OC2	F10039757	F10041410	F10042033
Spacer 3, Lead End L2	B2-OC3	F10039758	F10041412	F10042034
Saddle, Lead End L2	B2-OC4	F10039759	F10041408	F10042031
Splice block, Lead End L2	B2-OC5	F10039893	-	F10042600
Spacer 1, Return End L2	B2-OR1	F10039753	F10041403	F10042029
Spacer 2, Return End L2	B2-OR2	F10039754	F10041406	F10042030
Saddle, Return End L2	B2-OR3	F10039755	F10041402	F10042028

2.4 Wedges

Each layer of the QXFA coil has one type of wedge. Witness notches are added to each wedge for identification and orientation during coil fabrication. These wedges are made of phosphor bronze in order to have thermo-mechanical properties close to the Nb₃Sn cable during magnet cooldown. During coil heat treatment the Nb₃Sn cable shrinks and pole parts do not expand with increasing temperature as much as the wedges. Therefore, wedges are segmented with small gaps (Figure 3.2) between them in order to accommodate differential expansion during the heat treatment. Table 2.3 lists the wedge name and the drawing ID.

Table 2.3 QXFA Coil Wedges

Name	Drawing ID	Qty. per coil
QXFA Coil L1 Wedge_Long	F10068150	10
QXFA Coil L1 Wedge_Short	F10068151	2
QXFA Coil L2 Wedge_Long	F10068148	10
QXFA Coil L2 Wedge_Short	F10068149	2

The L1 wedge radii are 75.127 mm and 93.526 mm, with the profile tolerance (+0.06 mm, -0.02 mm). L1 wedge_long is 739.4 mm ± 0.3 mm and L1 wedge_short is 367.0 mm ± 0.3 mm in length. The L2 wedge radii are 94.44 mm and 112.84 mm, with the profile tolerance (+0.02 mm, -0.06 mm). L2 wedge_long is 739.4 mm ± 0.3 mm and L2 wedge_short is 321.0 mm ± 0.3 mm in length. The deviation from the straightness is 1.67 mm/m. Figure 2.5 shows the dimension and tolerance of L1 wedges, and Figure 2.6 shows the dimension and tolerance of L2 wedges.

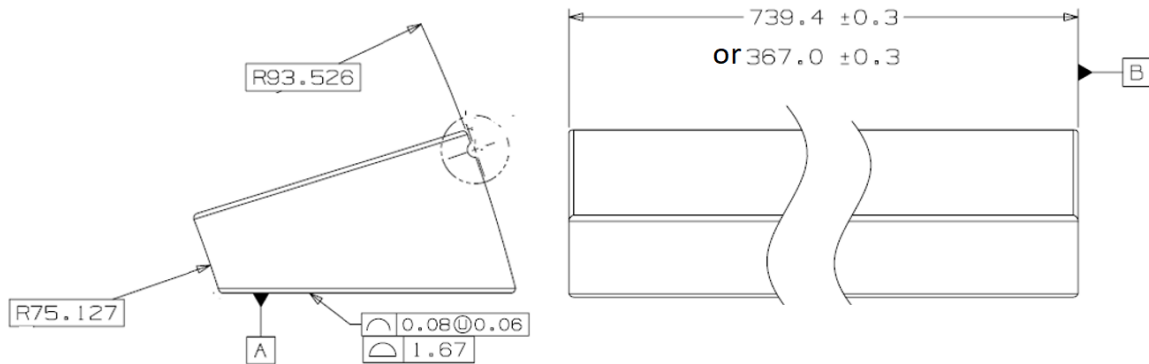

Figure 2.5 L1 Wedges

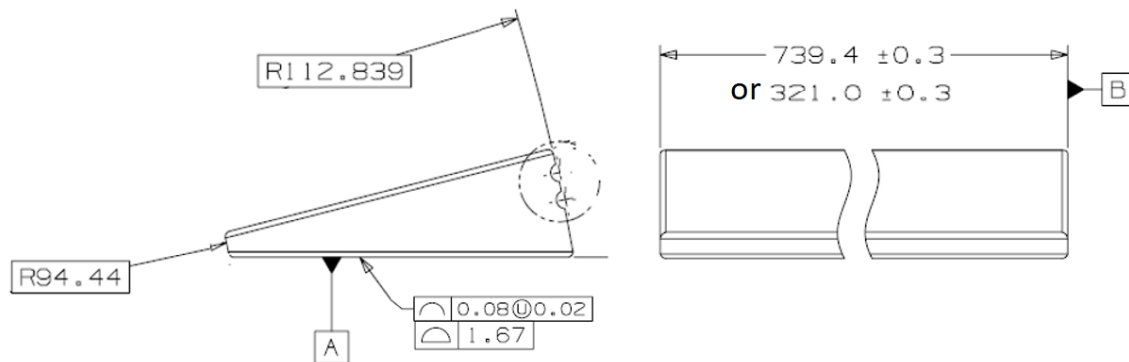

Figure 2.6 L2 Wedges

2.5 Quench Heater Trace

The quench heaters (QH), with the drawing ID SU-1009-8330A, are designed to protect the coils in case of quench during MQXFA magnet operation. Once the quench is detected, Heater Firing Units (HFU) are triggered to introduce a current through the QH strips attached to the coil

and heat up the conductor by heat diffusion. The QHs are photoetched on a 50 μm polyimide insulation layer (trace). QXFA coils have QHs only on the coil outer surface. Figure 2.7 shows the design of the QXFA coil outer layer quench heater. The overall trace length is 4532 mm. The traces shrink slightly during QH photoetching and are accepted if they can be stretched back to nominal dimension without any tooling. There are 4 quench heater strips, PHB01, 02, 03 and 04, with each circuit strip length 4506 mm and width 20 mm. These strips are made of stainless steel with copper plated sections to lower the resistance between heating stations, shown in Figure 2.7 as “boxes area indicate stainless only area”. The resistance of each circuit is between 1.7 Ω to 2.2 Ω . Each QH trace is required to pass 3.70 kV Hipot test between QHs and ground, with leakage current less than 10 μA [6].

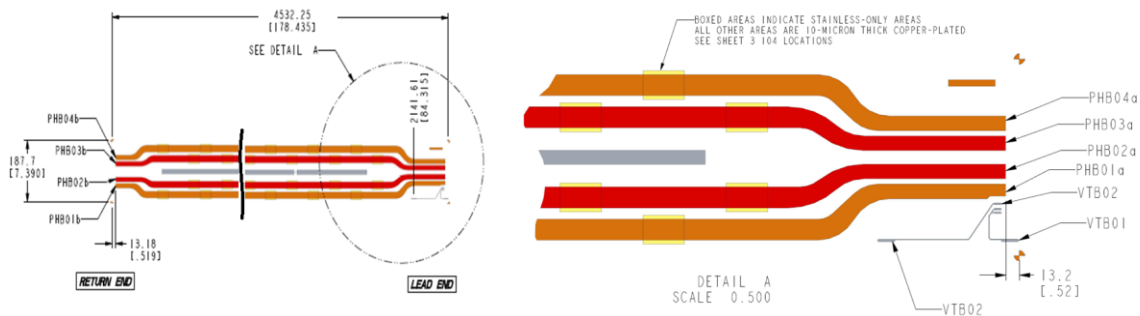

Figure 2.7 QXFA Coil QH Trace

2.6 NbTi Cable Lead

After the coil reaction, the Nb_3Sn lead is soldered to two pieces of NbTi cable which is provided by CERN, with the strand specification and cable specification shown in Table 2.4 and Table 2.5. The cable dimension is shown in Figure 2.8.

Table 2.4 NbTi Cable Strand Specification.

NbTi Cable Strand	
Coating type	Sn5wt%Ag
Diameter after coating (mm)	1.065 ± 0.0025
Copper to superconductor ratio	1.65 ± 0.05
Filament diameter (μm)	7
Number of filaments	~ 8900
RRR	≥ 150
Twist pitch after cabling (mm)	18 ± 1.5
Critical current (A) 10T, 1.9 K	≥ 515
9 T, 1.9 K	
ΔM at 0.5 T and 1.9 K (mT)	≤ 30

Table 2.5 NbTi Cable Specification.

Strand Type	NbTi
Strand Diameter	1.065 mm
Number of Strands	34
Width	18.15 +/- 0.05 mm
Mid Thickness	1.92 +/- 0.01 mm
Keystone angle	0.00 +/- 0.1 deg.
Pitch length	125 +/- 3 mm

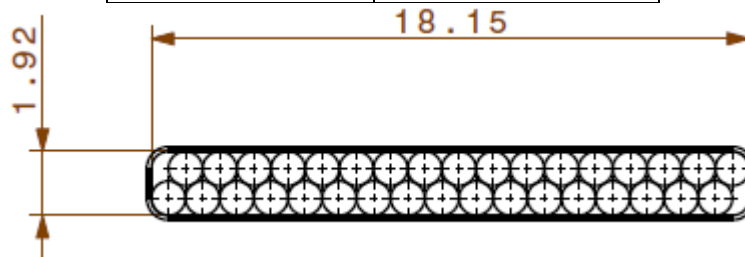

Figure 2.8 NbTi Cable

The minimum NbTi cable length for IL coil is 3045 mm and for OL coil is 1230 mm, noted in the drawing QXFA Coil Assembly_Impregnation (F10115848 Rev.-). After cable lead soldering, 3 mil (75 μ m) thick Kapton insulation is wrapped around the splice ground insulation, see Figure 2.9. Two (2) redundant voltage taps are used for quench detection in each internal MQXFA Nb₃Sn-NbTi splice.

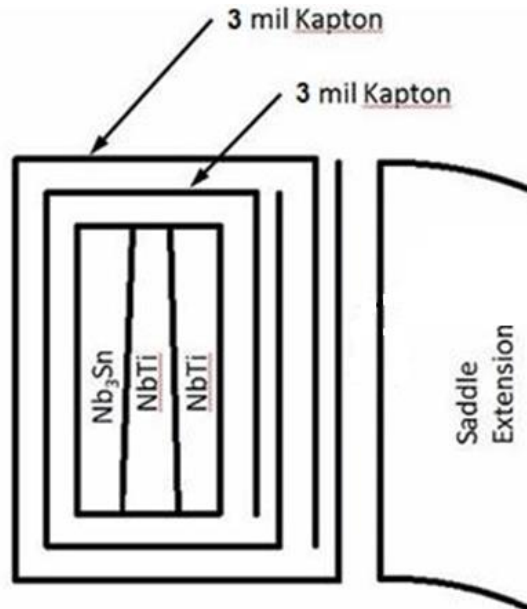

Figure 2.9 Insulation around the coil lead



QXFA Series Coil Production Specification

US-HiLumi-doc-2986

Date: 6/9/20

Page 15 of 26

2.7 Other Materials

The insulation system is designed and implemented to protect the coil from electrical failure during coil fabrication, magnet assembly and operation. Five layers of 125 μm thick heat cleaned S2 glass tape (total 625 μm in thickness) are used between the insulated Nb_3Sn cable and the Ti alloy pole parts. S2 glass sleeve with 125 μm thickness, heat cleaned, is installed over the copper wedges. One layer of heat cleaned S2 glass tape is used between the insulated Nb_3Sn cable and the SS end parts with Al_2O_3 coated surfaces. Between L1 and L2 coil, 660 μm thick interlayer insulation, combination of single-layer Hexcel 4522 and double-layer BGF 6781, is laser cut, pre-cured with binder for the purpose of strengthening and surface flattening. When cable insulation needs to be repaired, 75 μm thick heat cleaned S2 glass tape is used. Between the quench heater trace and the coil OD, additional 50 μm Kapton insulation is used at both ends of the coil. Over the coil, two layers of S2 glass sheet on OD (310 μm thickness), one layer of S2 glass sheet on ID (250 μm thickness), and one piece of G11 shim on each midplane (125 μm thickness) are used. Table 2.6 lists these insulation materials.

Table 2.6 Insulation Materials in the Coil

Name	Material	Drawing ID	Thickness
Pole Insulation	Heat cleaned S2 glass tape	F10133503	125 μm
Wedge Insulation	Heat cleaned S2 glass sleeve	F10132315	125 μm
End Part Insulation	Heat cleaned S2 glass tape	F10133814	200 μm
Interlayer Insulation	BGF 6781 and Hexcel 4522 S2 glass sheet	F10052204	660 μm
Cable Insulation Repair	Heat cleaned S2 glass tape	F10133815	75 μm
L2 LE Trace Insulation	Kapton	F10104831	50 μm
L2 RE Trace Insulation	Kapton	F10104911	50 μm
Coil Insulation _ Outer layer	Hexcel 4522 S2 glass sheet	F10058890	310 μm
Coil Insulation _ Inner layer	BGF 6781 S2 glass sheet	F10058894	250 μm
Midplane Shim	G11	F10108832	125 μm

There are other materials used during coil fabrication, which remain in the coil after fabrication, serving different purposes. These materials are listed in Table 2.7.



QXFA Series Coil Production Specification

US-HiLumi-doc-2986

Date: 6/9/20

Page 16 of 26

Table 2.7 Other Materials in the Coil

Name	Material	Drawing ID
Ramp turn Shim	S2 glass	F10039954
8 mm Dia. 24 mm Length Dowel Pin	Ti-6Al4V	F10133226
M6x1x25LG SHCS	SS 316	FC0006091
Splice Filler	G11	F10108761
L1 LE Splice Block Pocket Glass Filler	S2 glass	F10105542
L1 RE Saddle Pocket Glass Filler	S2 glass	F10105551
L2 LE Splice Block Pocket Glass Filler	S2 glass	F10105554
L2 RE Saddle Pocket Glass Filler	S2 glass	F10105556
OL Coil End Conductor Group Filler	S2 glass	F10105539
IL Coil End Conductor Group Filler	S2 glass	F10110210
Glass Paste Filler _ heat cleaned	S2 glass	FC0066104
QXFA Inner Splice VT Flag Trace	Kapton, Stainless Steel, Copper	F10058887
Voltage Tap	Copper	FC0051917
Voltage tap wires HH2619	Silver plated copper, Kapton, Polyimide	FC0067203
Quench heater wires HH1819	Silver plated copper, Kapton, Polyimide	FC0067205
Curing Binder	CTD 1202	FC0067622
Impregnation Epoxy	CTD 101k	FC0067623
Solder	96/4 Tin/silver	FC0067620
Soldering Flux	MOB 39	FC0067621

3 QXFA Coil Fabrication Specification: Winding and Curing

This chapter lists the major parameters and specifications during the process of coil winding and curing, regardless of the fabrication location.

- Cable length:
 - Cable required for winding: minimum 441 m
 - L1 cable: minimum 195 m
 - L2 cable: minimum 246 m
- Cable tension during winding:
 - Maximum tension: 30 kg.
 - Minimum for straight section of first turn: 10 kg
 - Minimum for straight section of all other turns: 18 kg
- Initial inner layer pole gap: 12.7 mm \pm 0.25 mm, see Figure 3.1.
 - Gaps shall be uniformly distributed among the 10 joints.



Figure 3.1 L1 Pole Set and Pole Gaps

- Initial wedge gap: 22.75 mm \pm 2 mm, see Figure 3.2.
 - Gaps between wedges and end spacers shall be approximately 2 mm.
 - Gaps between wedges segments shall be approximately 3.75 mm.

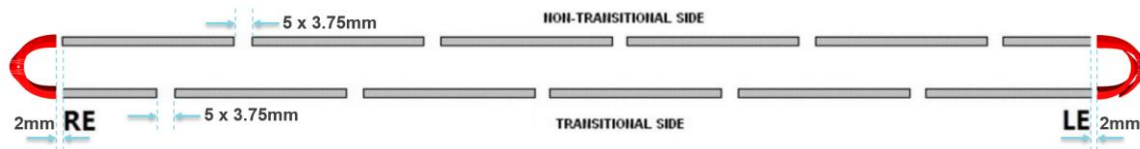

Figure 3.2 Wedge Set and Wedge Gaps

- Cable stability is limited. To reduce issues with cable strands popping out of register, CTD 1202 binder shall be applied to the cable in the coil ends and be cured with a heat gun prior to winding each end turn.
- CTD 1202 binder is applied to the wound coil prior to curing (1.5 \pm 0.2 gram/m of cable).
 - L1 binder: 250 – 330 grams.
 - L2 binder: 330 – 415 grams.
 - Binder shall not be applied to the first 3 turns at the pole.



QXFA Series Coil Production Specification

US-HiLumi-doc-2986
Date: 6/9/20
Page 18 of 26

- Coil shall be cured in a fixed cavity of the nominal coil size. The gap between the press platen and the mold cavity shall be less than .04 mm prior to initiating cure cycle.
- Coil Curing Cycle:

	Step	Description	Rate	Time
Step 1	Ramp	from 20 °C to 150 °C	5 C/min max	
Step 2	Soak	150 +40 / -0 °C		105 ± 10 min
Step 3	Cool	cool to 20 °C	Natural Cool	

4 QXFA Coil Fabrication Specification: Heat Treatment

Coil heat treatment shall take place in a gas tight oven using an automatic program. The reaction fixture must be sufficiently gas tight to assure internal overpressure with 10 liter/min argon flow. The argon flow during the whole heat treatment must be equal or higher than 10 liter/minute.

The specification for the coil heat treatment cycle is shown in Table 4.1. Coil heat treatment cycle is measured by thermocouples set in thermal contact with the reaction fixture. The durations and ramp rates for the oven control may be varied in order to achieve the target temperature for the reaction fixture. Witness samples are the main tool used to verify quality of the heat treatment cycle. Witness samples shall be tested shortly after each coil heat treatment and shall demonstrate critical current and RRR above requirement values [1]. The thermocouples set on the reaction fixture are used to verify the uniformity of the heat treatment on the whole coil.

Table 4.1: Specification for QXFA Coil Reaction Cycle.

	Step	Description	Ramp Rate	Time
Step 1	Ramp	from 20 °C to 210 °C	25 C/hour	
Step 2	Soak	210 °C		48 hours
Step 3	Ramp	from 210 °C to 395 °C	50 C/hour	
Step 4	Soak	395 °C		48 hours
Step 5	Ramp	from 395 °C to 665 °C	50 C/hour	
Step 6	Soak	665 °C		50 hours
Step 7	Ramp	from 665 °C to 20 °C		~ 80 hours

Notes:

- At least nine thermocouples shall be set on the reaction fixture in order to monitor its temperature around coil lead end, return end and center.
- During ramps the average of the thermocouples on the fixture shall not exceed the ramp rates listed above.
- Before step 3 the temperature of the thermocouples set on the reaction fixture shall never exceed 217°C.
- The temperature of all thermocouples set on the reaction fixture shall be within +/- 7 °C of target temperature during step 2 (soak at 210 °C) and step 4 (soak at 395 °C). Scope for this specification starts 4 hours after the start of the soak (per the definition below) and ends at the start of the subsequent ramp.
- The temperature of all thermocouples set on the reaction fixture shall be within +/- 5 °C of target temperature during step 6 (soak at 665 °C). Scope for this specification starts 4 hours after the start of the soak (per the definition below) and ends at the start of the subsequent ramp.
- For steps 2 and 4: soak time starts when the average temperature of the thermocouples set on the fixture is higher than target temperature – 5 °C, and stops when it is higher than target temperature + 5 °C during the following ramp.



QXFA Series Coil Production Specification

US-HiLumi-doc-2986

Date: 6/9/20

Page 20 of 26

- For step 6: soak time starts when the average temperature of the thermocouples set on the fixture is higher than target temperature – 5 °C, and stops when it is lower than target temperature - 5 °C.
- Soak time shall be longer than target time – 1 hour, and shorter than target time + 3 hours.
- All thermocouples set on the reaction fixture shall be calibrated at least once per year.
- The data acquisition system used for the thermocouples set on the reaction fixture shall have a UPS unit.

In case a coil heat treatment is stopped (for instance by a power outage) the oven may be restarted after checking its functionality, the data acquisition and the argon flow. Restart procedure shall follow these guidelines:

- If the cycle stopped during steps 1, 3 or 5: the heat treatment cycle may be restarted from the step where it stopped.
- If the cycle stopped during steps 2 or 4: the heat treatment cycle may be restarted using the ramp rate of the previous step; and the soak time shall be equal to the time in table 5.3 minus time spent on that step before the stop.
- If the cycle stopped during step 6: the heat treatment cycle may be restarted using the ramp rate of step 5; and the soak time shall be equal to the time in table 5.3 minus the time when the average of the thermocouples set on the reaction fixtures were above target temperature – 5 °C.
- A Discrepancy Report shall be initiated and the L2 must be informed.



5 QXFA Coil Fabrication Specification: Epoxy Impregnation

This chapter collects the requirements that are imposed on the process to insure uniform epoxy impregnated QXFA coils. The requirements include mixing and degassing of the CTD-101K epoxy, degassing of the coil, resin transfer, cure cycles and various QA/QC steps and monitoring.

5.1 Epoxy Mixing and Degassing

Epoxy used shall be CTD-101K. The epoxy is 3 parts, Part A epoxy resin, Part B hardener, and Part C accelerator. The mixing ratio is by weight and shown in Table 5.1 [16].

Table 5.1 CTD-101K Mixing Ratio

Part A (resin)	Part B (hardener)	Part C (accelerator)
100 ± 5%	90 ± 5%	1.5 ± 2%

5.1.1 Pre-Mixing

Prior to mixing components, Part A and Part B shall be heated to 50° C ± 5° C for ~20 hours, or at least 1 hour at 55 - 60° C. Heating is used to eliminate crystals that may form in the resin and to preheat the components [16].

5.1.2 Epoxy Mixing and Degassing

Mixing and degassing shall be in a heated vacuum tank with a mixing device. The mixing temperature shall be 50 - 55° C, mixing vacuum 200 - 1000 mTorr measured at the mixing tank, and the mixing duration is at least 1 hour [17].

5.1.3 Storage

Epoxy storage shall be at room temperature (20-22° C) and in a dry environment. After opening, the use of dry nitrogen in the epoxy container to reduce the absorption of moisture is recommended [18].

5.2 Coil Degassing

Coil degassing in vacuum shall ramp to 110° C ± 10° C and hold for 8 hours +/- 1 hour. The coil in the vacuum system shall cool to 53 ° C ± 5° C and be below 500 mTorr, measured at the coil opposite the pumping port, before epoxy impregnation begins.

5.3 Resin Transfer

The coil vacuum shall be between 700 – 2000 mTorr during resin transfer, but no less than the resin outgassing pressure. The fill rate is 8 - 22 ml/min with a coil temperature between 53° C ± 5° C.

5.4 Cure Cycle

The epoxy coil average cure cycle shall be 5 – 7 hours at 110° C ± 10° C followed by 16 – 18 hours at 125° C ± 10° C. The overall impregnation cycle is shown in Figure 5.1.

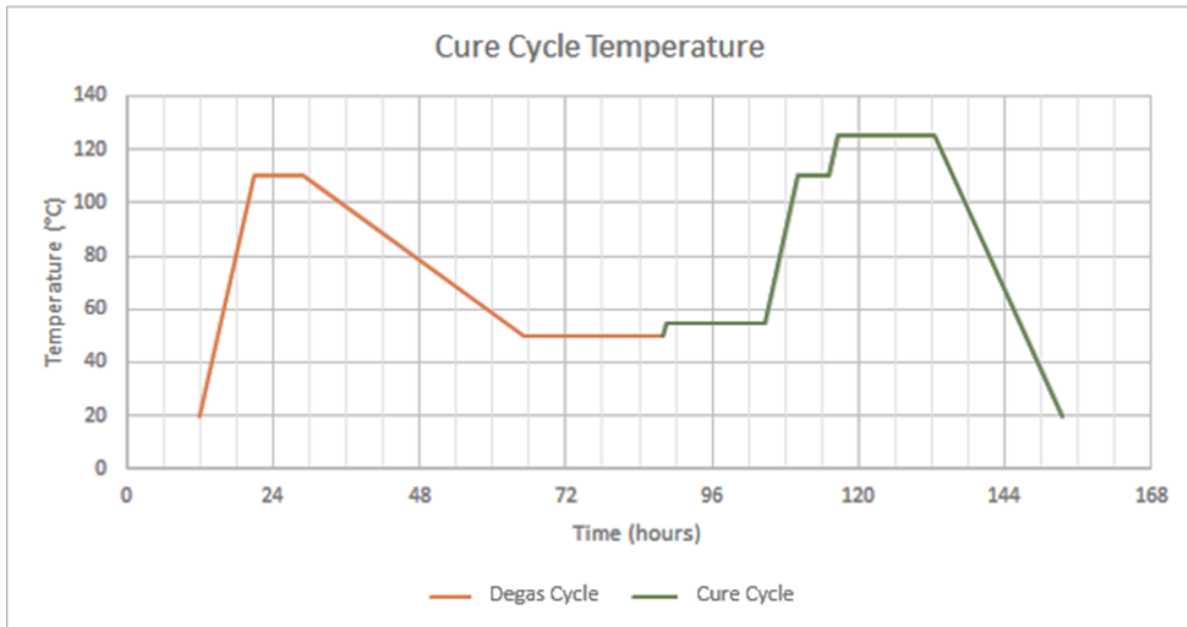

Figure 5.1 Plot of degas cycle and cure cycle.

5.5 Quality Control

5.5.1 Epoxy impregnated coil

Samples for measurement of glass transition temperature (T_g) shall be extracted from each epoxy impregnated coil. Minimum number per coil is to extract and test 2 samples, which must be extracted from coil lead end and return end. Material for additional samples must be stored until tests show T_g with acceptable range. Acceptable range of T_g measurement is going to be set after results of T_g measurement of samples extracted from coils QXFP03, QXFP04 and pre-series coils are available.

5.5.2 FTIR

Prior to first-time use, each batch of epoxy components is verified using FTIR per the QC Plan for QXFA Coil Parts [11]. The initial test will serve as the baseline for future deliveries.

5.5.3 Silicone

Avoid using RTV silicone, instead use Neutral Cure silicone or SCV grade silicone. If RTV silicone is used, insure it is fully cured prior to coil degassing.

6 QXFA Coil Fabrication Specification: Instrumentation

After coil is impregnated, the instrumentation wires are soldered to the trace taps using Staybrite 96/4 and Flux MOB 39. After soldering, Stycast or Green Putty is used to cover the wires inside the pockets of the end parts. Figure 6.1 shows the wires on coil ID, and Figure 6.2 shows the wires on coil OD, where VT represents Voltage Tap and PH represents Protection Heater. Table 6.1 lists the instrumentation wire type and length. Each wire must have a label showing coil number and VT/QH number.

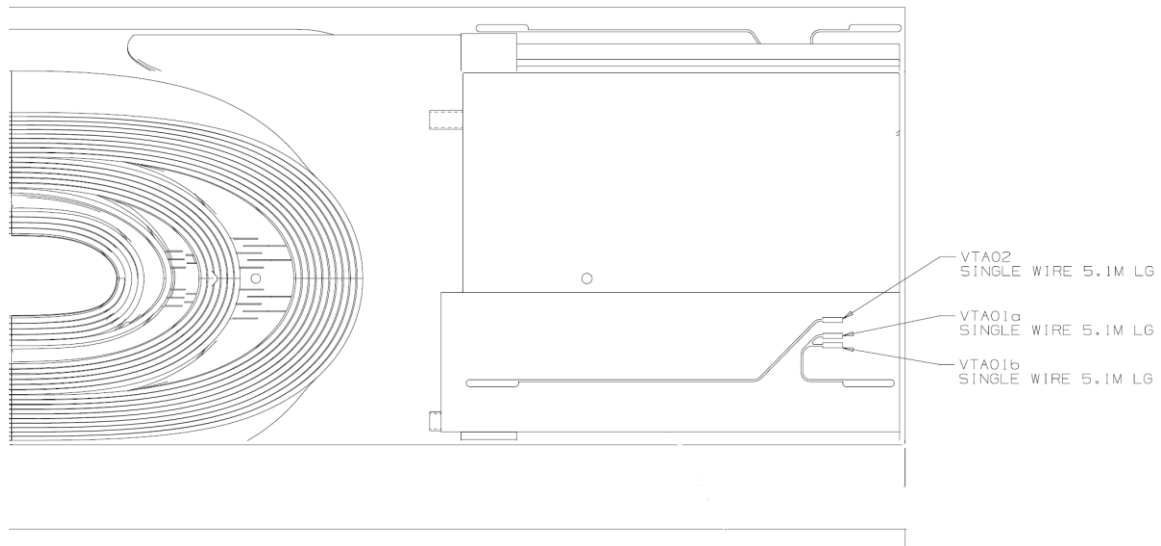

Figure 6.1 Coil Inner Layer (IL) Instrumentation Wires



Figure 6.2 Coil Outer Layer (OL) Instrumentation Wires



QXFA Series Coil Production Specification

US-HiLumi-doc-2986

Date: 6/9/20

Page 24 of 26

Table 6.1 Instrumentation Wire Type and Length

Label	Location	Type	Min. Length	Note
VTA01a	IL LE	Axon 26 AWG HH2619	5.1 meter	Single wire
VTA01b	IL LE	Axon 26 AWG HH2619	5.1 meter	Single wire
VTA02	IL LE	Axon 26 AWG HH2619	5.1 meter	Single wire
VTB01a	OL LE	Axon 26 AWG HH2619	5.1 meter	Single wire
VTB01b	OL LE	Axon 26 AWG HH2619	5.1 meter	Single wire
VTB02	OL LE	Axon 26 AWG HH2619	5.1 meter	Single wire
PHB01a	OL LE	Axon 18 AWG HH1819	5.1 meters	Single wire
PHB02a	OL LE	Axon 18 AWG HH1819	5.1 meter	Single wire
PHB03a	OL LE	Axon 18 AWG HH1819	5.1 meter	Single wire
PHB04a	OL LE	Axon 18 AWG HH1819	5.1 meters	Single wire
PHB01b	OL RE	Axon 18 AWG HH1819	1.0 meters	Twisted with PHB04b
PHB02b	OL RE	Axon 18 AWG HH1819	1.0 meters	Twisted with PHB03b
PHB03b	OL RE	Axon 18 AWG HH1819	1.0 meters	Twisted with PHB02b
PHB04b	OL RE	Axon 18 AWG HH1819	1.0 meters	Twisted with PHB01b

7 Final Coil QC and Shipment

After fabrication is complete the coil must pass all final electrical QC tests before shipment [6]. Coil summary data must be uploaded on the Coil Interface Traveler [12] together with all Discrepancy Reports, including Non-Conformity Reports (NCR), and travelers. If there are no critical NCRs, after reviewing data, the Coil Fabrication L3 may approve the coil for shipment to LBNL. If there are critical NCRs the MQXFA Magnets L2 must be informed as soon as possible.

At LBNL the L3 for Structure Fabrication and Magnet Assembly performs visual inspection, post-shipment electrical tests [6], and CMM measurements shortly after coil reception, and upload data on the Coil Interface Traveler [12]. CMM measurements are performed and dispositioned according to [7].

Accelerometer data are analyzed by the Magnet Integration and Coordination L3, and a summary is uploaded on the Coil Interface Traveler [12].

After all data are uploaded on the Coil Interface Traveler [12] the Coil Fabrication L3, the Structure Fabrication and Magnet Assembly L3, and the MQXFA Magnets L2 must approve the coil before next step in the workflow.

Finally, before use in an MQXFA magnet, all candidate coils must pass the Coil Acceptance Review.

8 Coil Handling and Shipment Requirements

Specification for MQXFA coil handling and shipment are in *MQXFA Coils Handling & Shipping Requirements* [19].



QXFA Series Coil Production Specification

US-HiLumi-doc-2986

Date: 6/9/20

Page 26 of 26

References

- 1 MQXFA Final Design Report, US-HiLumi-Doc-948.
- 2 MQXFA Functional Requirements Specification, US-HiLumi-Doc-36.
- 3 Design Criteria for MQXFA Superconducting Elements, US-HiLumi-doc-885.
- 4 Report for Q1/Q3 CryoAssembly Preliminary Design Review and MQXFA Magnet Final Design Review, US-HiLumi-doc-1187.
- 5 MQXFA Electrical design criteria, US-HiLumi-Doc-826.
- 6 QXFA Coil Fabrication Electrical QA, US-HiLumi-doc-521.
- 7 Impregnated coil dimensional QA plan at LBNL, US-HiLumi-doc-3043.
- 8 MQXFA Coil CMM Profile Measurement Locations, US-HiLumi-doc-2362.
- 9 ICD WBS 302.2.04-06, US-HiLumi-Doc-270.
- 10 ICD WBS 302.2.04-05, US-HiLumi-Doc-264.
- 11 QC Plan for QXFA Coil Parts, US-HiLumi-Doc-2168.
- 12 AUP coil interface traveler, <https://vector-offsite.fnal.gov/Tools/TravelerWriter/TravelerWriterPreviewDocument.asp?qsSpecificationID=1783>
- 13 AUP Superconductor Quality Plan, US-HiLumi-doc-903.
- 14 Disposition of Non-Conforming Plasma Coated End Parts, US-HiLumi-Doc-2140.
- 15 Coil End Part Design Procedure, FNAL Technical Report TD-98-053.
- 16 Composite Technology Development, CTD-101K Processing and Handling Guidelines, OM390502 Rev B, 2020, US-HiLumi-doc-2444.
- 17 Composite Technology Development, CTD-101K Mixing Instructions, 2018, US-HiLumi-doc-2444.
- 18 Composite Technology Development, Nitrogen Purge Process for Prevention of Moisture Contamination, PS900130, Rev PR, 2018, US-HiLumi-doc-2444.
- 19 MQXFA Coils Handling & Shipping Requirements, US-HiLumi-doc-820.