

Mu2e-II Workshop (ix) Introduction

Frank Porter
July 21, 2021
DocDB-nnnnn

This meeting will be recorded

Mu2e-II workshops

Recent past workshops

For earlier workshops, see the Mu2e-II calendar at:

https://mu2eii-internal-wiki.fnal.gov/wiki/Main_Page#Calendar

Workshop dates	Links to recordings
Wednesday, September 23 https://indico.fnal.gov/event/45632/	https://caltech.zoom.us/rec/play/xbOzK448M0VhhDArf9UE8AjiOKdshh4et0tYOOhtViPn3qv_eG95CkQUOHQ0_SzeJ8pxVzw5M0PolvjD.l-zdhaNXvu3i5SII?autoplay=true&startTime=1600873315000
Wednesday, October 28 https://indico.fnal.gov/event/45937/	https://caltech.zoom.us/rec/share/zCGxa2uJwAKwONXm7pyiqrrLPJvixTaNHkY2cxHRDjtm_bmWOYqraV8D9ynUMATk.JNeSkLhSj4-Hfcof
Wednesday, December 9 https://indico.fnal.gov/event/46433/	https://caltech.zoom.us/rec/share/xXVV4YURBMeRsnF0GLQSGAPv-FJ466HNnTGze3VeiAoooyUcRSU7cP16QBwlvNPv.XvSqSC_JVmuSKVA9
Wednesday, March 3 https://indico.fnal.gov/event/47787/	https://caltech.zoom.us/rec/share/po6RL9ZZL27yeF8sjUZ9Wk9xcBw_wqm-TYgRmSNjn6yUYBE5mnb5Myza-ez2k3tFV.deUj8dQcDWOVSqAU
Wednesday, April 28, 2021 https://indico.fnal.gov/event/48516/	https://caltech.zoom.us/rec/share/NM_b0LyWSJopNa_YAu9LXmfjJ0_5XrCmjXkmfwCoqj9VtBqVFKeA0N4pouLDKGMz.1f96W6EOVkyUsnT4

Mu2e-II collaboration/author list

- Please respond (to fcpc@caltech.edu)
 - Philosophy is people need to sign on
 - So please send me an email if you haven't already
 - Also, please check that I got your information right!
- I will make sure anyone on the list is also on the Mu2e-II email list
 - That is: mu2eii@listserv.fnal.gov
 - The email list is a superset of the collaboration list
- Collaboration/author list is available from the internal Mu2e-II wiki page
 - https://mu2eii-internal-wiki.fnal.gov/wiki/Main_Page#Mu2e-II_Collaboration_and_Author_list
- Also directly accessible with link
 - <https://caltech.app.box.com/file/793439425745?s=gkidbcqykvhrmfnl85rfct3z6ybhfqb>

Mu2e-II collaboration/author list, page 1

Sequence	Name	Email	Institution	Address	Name on author list
1	Daniel Ambrose	ambr0028@unm.edu	University of Minnesota	Minneapolis, Minnesota 55455, USA	D. Ambrose
2	A. Artikov	akram@jinr.ru	Joint Institute for Nuclear Research	Dubna, Russia 141980	A. Artikov
3	N. Atanov	atanov@jinr.ru	Joint Institute for Nuclear Research	Dubna, Russia 141980	N. Atanov
4	Richard Bonventre	rbonventre@lbl.gov	Lawrence Berkeley National Laboratory	Berkeley, California 94720, USA	R. Bonventre
5	Leo Borrel	lborel@caltech.edu	California Institute of Technology	Pasadena, CA 91125	L. Borrel
6	David Norvil Brown	david.brown@louisville.edu	University of Louisville	Louisville, Kentucky 40292, USA	D. N. Brown
7	Myron Campbell	myron@umich.edu	University of Michigan	Ann Arbor, Michigan 48109, USA	M. Campbell
8	Brendan Casey	bck.casey@gmail.com	Fermi National Accelerator Laboratory	Batavia, Illinois 60510, USA	B.C.K. Casey
9	Raymond L. Culbertson	rlc@fnal.gov	Fermi National Accelerator Laboratory	Batavia, Illinois 60510, USA	R. Culbertson
10	Mary Anne Cummings	maccc@fnal.gov	Muons Inc.	Batavia, Illinois 60510, USA	M. A. C. Cummings
11	Yu.I. Davydov	davydov@jinr.ru	Joint Institute for Nuclear Research	Dubna, Russia 141980	Yu.I. Davydov
12	Sergei Denisov	sergev.denisov@ihep.ru	NRC Kurchatov Institute, IHEP	142281, Protvino, Moscow region, Russia	S. Denisov
13	Simone Donati	simone.donati@gmail.com	Università di Pisa; INFN Sezione di Pisa	I-56127 Pisa, Italy	S. Donati
14	(Edmond) Craig Dukes	ecd3m@virginia.edu	University of Virginia, Charlottesville	Virginia 22904, USA	E. C. Dukes
15	Bertrand Echenard	echenard@caltech.edu	California Institute of Technology	Pasadena, CA 91125	B. Echenard
16	Valery Evdokimov	valery.evdokimov@ihep.ru	NRC Kurchatov Institute, IHEP	142281, Protvino, Moscow region, Russia	V. Evdokimov
17	Andrei Gaponenko	gandr@fnal.gov	Fermi National Accelerator Laboratory	Batavia, Illinois 60510, USA	A. Gaponenko
18	Antonio Gioiosa	antonio.gioiosa@df.unipi.it	Università di Pisa; INFN Sezione di Pisa	I-56127 Pisa, Italy	A. Gioiosa
19	Simona Giovannella	simona.giovannella@lnf.infn.it	Laboratori Nazionali di Frascati dell'INFN	I-00044 Frascati, Italy	S. Giovannella
20	Valerio Giusti	valerio.giusti@unipi.it	Università di Pisa; INFN Sezione di Pisa	I-56127 Pisa, Italy	V. Giusti
21	V. Glagolev	vglagolev@jinr.ru	Joint Institute for Nuclear Research	Dubna, Russia 141980	V. Glagolev
22	Hank Glass	glass@fnal.gov	Fermi National Accelerator Laboratory	Batavia, Illinois 60510, USA	H. D. Glass
23	Douglas A. Glenzinski	douglasg@fnal.gov	Fermi National Accelerator Laboratory	Batavia, Illinois 60510, USA	D. A. Glenzinski
24	Lisa Goodenough	goodenou@fnal.gov	Fermi National Accelerator Laboratory	Batavia, Illinois 60510, USA	L. Goodenough
25	Robert Craig Group	rcg6p@virginia.edu	University of Virginia, Charlottesville	Virginia 22904, USA	R. G. Group
26	Julian Heeck	heck@virginia.edu	University of Virginia, Charlottesville	Virginia 22904, USA	J. Heeck
27	Michael Hedges	hedges7@purdue.edu	Purdue University	West Lafayette, Indiana, 47907, USA	M. T. Hedges

Mu2e-II collaboration/author list, page 2

28	Ken Heller	heller@umn.edu	University of Minnesota	Minneapolis, Minnesota 55455, USA	K. Heller
29	(James) A. Hocker	hocker@fnal.gov	Fermi National Accelerator Laboratory	Batavia, Illinois 60510, USA	A. Hocker
30	(Timothy) Matthew Jones	jones105@purdue.edu	Purdue University	West Lafayette, Indiana, 47907, USA	M. Jones
31	Cole Kampa	colekampa2024@u.northwestern.edu	Northwestern University	Evanston, Illinois 60208, USA	C. Kampa
32	Vadim Kashikhin	vadim@fnal.gov	Fermi National Accelerator Laboratory	Batavia, Illinois 60510, USA	V. Kashikhin
33	Yury Kolomensky	ygkolomensky@lbl.gov	University of California, Lawrence Berkeley National Laboratory	Berkeley, California 94720, USA	Yu. G. Kolomensky
34	Alexander Kozelov	alexander.kozelov@gmail.com	NRC Kurchatov Institute, IHEP	142281, Protvino, Moscow region, Russia	A. Kozelov
35	Robert K. Kutschke	kutschke@fnal.gov	Fermi National Accelerator Laboratory	Batavia, Illinois 60510, USA	R. K. Kutschke
36	Mark Lancaster	mark.lancaster@manchester.ac.uk	University of Manchester	Manchester, M13 9PL, UK	M. Lancaster
37	Kevin Lynch	klynch@york.cuny.edu	York College and the Graduate Center, The City University of New York	New York, New York 11451, USA	K. Lynch
38	Michael MacKenzie	michaelmackenzie@u.northwestern.edu	Northwestern University	Evanston, Illinois 60208, USA	M. MacKenzie
39	Matteo Martini	Matteo.Martini@Inf.infn.it	Laboratori Nazionali di Frascati dell'INFN, I-00044 Frascati, Italy; Universit'a degli Studi Guglielmo Marconi, 00193, Rome, Italy		M. Martini
40	Sophie Middleton	smidd@caltech.edu	California Institute of Technology	Pasadena, CA 91125	S. Middleton
41	Stefano Miscetti	stefano.miscetti@Inf.infn.it	Laboratori Nazionali di Frascati dell'INFN	I-00044 Frascati, Italy	S. Miscetti
42	Stefan E. Mueller	Stefan.Mueller@hzdr.de	Helmholtz-Zentrum Dresden-Rossendorf	Dresden 01328, Germany	S. E. Mueller
43	Alexey Popov	popov_al@ihep.ru	NRC Kurchatov Institute, IHEP	142281, Protvino, Moscow region, Russia	A. Popov
44	James L. Popp	jpopp@york.cuny.edu	York College and the Graduate Center, The City University of New York	New York, New York 11451, USA	J. L. Popp
45	Frank C. Porter	fcpc@caltech.edu	California Institute of Technology	Pasadena, CA 91125	F. C. Porter
46	Dave Pushka	pushka@fnal.gov	Fermi National Accelerator Laboratory	Batavia, Illinois 60510, USA	D. Pushka
47	Reuven Rachamin	r_rachamin@hzdr.de	Helmholtz-Zentrum Dresden-Rossendorf	Dresden 01328, Germany	R. Rachamin
48	Gregory Rakness	grakness@fnal.gov	Fermi National Accelerator Laboratory	Batavia, Illinois 60510, USA	G. Rakness
49	Robert Szafron	rszafron@bnl.gov	Brookhaven National Laboratory	Upton, N.Y., 11973, USA	R. Szafron
50	Giovanni Tassielli	giovanni.tassielli@le.infn.it	INFN Sezione di Lecce	Lecce I-73100, Italy	G. F. Tassielli
51	Igor A. Vasilyev	igor.vasilyev@cern.ch	NRC Kurchatov Institute, IHEP	142281, Protvino, Moscow region, Russia	I. A. Vasilyev
52	I.I. Vasilyev	ivasilyev@jinr.ru	Joint Institute for Nuclear Research	141980 Dubna, Moscow region, Russia	I.I. Vasilyev
53	Mete Yucel	myucel@fnal.gov	Fermi National Accelerator Laboratory	Batavia, Illinois 60510, USA	M. Yucel
54	Anna Maria Zanetti	annamaria.zanetti@ts.infn.it	NFN Sezione di Trieste	I-34127 Trieste, Italy	A. M. Zanetti

Mu2e-II Working Groups

Email convenors if you wish to participate
Anyone can subscribe to email lists

Accelerator

mu2e-ii-accelerator@fnal.gov

Karie Badgley, Convenor, FNAL

David Neuffer, Convenor, FNAL

Eric Prebys, Convenor, UCD

Mary Anne Cummings, Muons, Inc.

Keegan Harrig, UCD

Andrei Gaponenko, FNAL

Vadim Kashikhin, FNAL

Kevin Lynch, CUNY

James Popp, CUNY

Diktys Stratakis, FNAL

- Accelerator meetings every other Thursday, 1PM CT. Next meeting July 29, 2021 (TBC)
- TBD, 2021 (10-12 CT): AF2/AF5/AF7/RP/NP target workshop (contact: Eric Prebys)
<https://indico.fnal.gov/event/46752/>

Radiation simulation and mitigation

mu2eii-radiation@fnal.gov

Michael MacKenzie, Convenor, Northwestern

Stefan Mueller, Convenor, HZDR

Vitaly Pronskikh, Convenor, FNAL

Anna Ferrari, Reuven Rachamin, HZDR

Vadim Kashikhin, FNAL

James Popp, CUNY

David Pushka, FNAL

Yuri Oksuzian – CRV

Sophie Middleton – Sensitivity

Giani Pezzullo - TDAQ

Theory

mu2eii-theory@fnal.gov

Lorenzo Calibbi, Convenor, Nankai U

Julian Heeck, Convenor, UVa

Robert Szafron, BNL

Yuichi Uesaka, Kyushu Sangyo University

Tracker

mu2eii-tracker@fnal.gov

Daniel Ambrose, Convenor, UMinn

Giovanni Tassielli, Convenor, INFN Lecce

David Brown, LBNL

Brendan Casey, FNAL

Manolis Kargiantoulakis, FNAL

James Popp, CUNY

Mete Yucel, FNAL

Tracker meetings every two weeks on Tuesdays 12AM CT
Next meeting August 3, 2021 (TBC)

Calorimeter

mu2eii-calorimeter@listserv.fnal.gov

David Hitlin, Convenor, Caltech

Luca Morescalchi, Convenor, INFN Pisa

Ivano Sarra, Convenor, LNF

Leo Borrell, Bertrand Echenard, Dexu Lin, Sophie Middleton,
James Oyang, Frank Porter, Liyuan Zhang, Renyuan Zhu, Caltech

Eleonora Diociaiuti, Raffaella Donghia, Simona Giovannella,
Fabio Happacher, Stefano Miscetti, LNF

Stefano Di Falco, Simone Donati, Antonio Gioiosa, Elena
Pedreschi, Franco Spinella, INFN Pisa

Cosmic Ray Veto

mu2eii-crv@listserv.fnal.gov

Craig Dukes, Convenor, Uva

Yuri Oksuzian, Convenor, ANL

Karen Byrum, Simon Corrodi, Peter Winter, Lei Xia, ANL

Raymond Culbertson, Gary Drake, Anna Pla-Dalmau, Greg Rakness, FNAL

Akram Artikov, Yuri Davydov, JINR, Dubna

Timothy Bolton, Glenn Horton-Smith, Yurii Maravin, Kres Neely, KSU

Gerald Blazey, Kurt Francis, Sergey Uzunyan, Vishnu Zutshi, NIU

Merrill Jenkins, U South Alabama

Steven Boi, Ralf Ehrlich, Stephen Goadhouse, Craig Group, UVa

Trigger/DAQ

mu2eii-tdaq@listserv.fnal.gov

Antonio Gioiosa, Convenor, INFN Pisa

Gianantonio Pezzullo, Convenor, Yale

Richard Bonventre, LBNL

Rebecca Chislett, UCL, [Tracker](#)

Raffaella Donghia, LNF

Bertrand Echenard, Caltech

Ryan Rivera, FNAL

Franco Spinella, INFN Pisa – [Calorimeter](#)

Craig Dukes, UVa - [CRV](#)

Sensitivity estimates

mu2e-ii-sensitivity@listserv.fnal.gov

Lisa Goodenough, Convenor, FNAL

Sophie Middleton, Convenor, Caltech

Yuri Oksuzian, Convenor, ANL

Rebecca Chislett, UCL

Michael Hedges, Purdue

Cole Kampa, Northwestern

Manolis Kargiantoulakis, FNAL

Michael MacKenzie, Northwestern

Snowmass 22 Schedule

Rare Processes & Precision Measurements Frontier

The rare processes and precision measurements frontier plans to pause activities until the end of August

- Will be about three “heartbeat” status meetings among the topical group conveners in that time but no workshops
 - CLFV coffee hours
 - Most recently, May 28, 10AM CT (tau CLFV), see: <https://indico.fnal.gov/event/49178/>
 - Generic discussion on approaches to improve theoretical calculations for muon conversion and decays
- Community members should pursue their individual physics interests as they wish
- At the end of August, will resume activities again with a schedule to be determined
- Plan to postpone Frontier meeting by one year to around May 2022

Mu2e-II Snowmass Schedule

March 15, 2022 deadline for submission of Mu2e-II contribution to arXiv

That is, we need to be “done” in eight months!

- This will serve as the input to the Topical Group Convenors
 - Their deadline for preliminary reports is May 31, 2022
- Mu2e-II aim for a “good first draft: by February 1, 2022

Outline and framework on Overleaf (read link):

<https://www.overleaf.com/read/mrbgttkmfgvq>

(let me know if you need edit link)

Mu2e-II talks

- If you plan to submit an abstract or give a Mu2e-II talk, or are invited to give such a talk, please
 - Email [Kevin Lynch](#) and [Frank Porter](#)
 - If you have an invitation, please email us even if you do not wish to accept – we may be able to suggest someone else
- Fermilab requirements – writeups
 - Acknowledgment should usually include:
 - This document was prepared by members of the Mu2e-II Collaboration using the resources of the Fermi National Accelerator Laboratory (Fermilab), a U.S. Department of Energy, Office of Science, HEP User Facility. Fermilab is managed by Fermi Research Alliance, LLC (FRA), acting under Contract No. DE-AC02-07CH11359.
 - Fermilab preprint number
 - <https://mu2e-docdb.fnal.gov/cgi-bin/private/ShowDocument?docid=4083>
- With byline, include:
 - “For the Mu2e-II Collaboration”
 - Optionally as applicable; “For the <appropriate group name> working group of the Mu2e-II Collaboration”

Mu2e-II talks – Material for Speakers

- Have added a “Materials for Speakers” section to the public Mu2e-II Wiki https://mu2eiiwiki.fnal.gov/wiki/Material_for_speakers
- Resource of “Blessed” material
- Please use while preparing Mu2e-II talks
 - Work in progress
 - Suggestions for additional material
 - Corrections
 - Removal of obsolete material

Mu2e-II Communication

- Public wiki page: <https://mu2eiiwiki.fnal.gov>
 - Please email Lisa or Frank if you wish to have write access
- Private wiki page:
https://mu2eii-internal-wiki.fnal.gov/wiki/Main_Page
 - SSO log-on
 - May need to contact Lisa or Frank to request access
 - This page has the Mu2e-II calendar with links to zoom, indico, etc.
- Mu2e-II mailing list: mu2eii@listserv.fnal.gov
- Mu2e-II Slack channel link:
 - <https://Caltech-tka1525.slack.com>

Mu2e-II Calendar

- On main page of **private** Wiki
https://mu2eii-internal-wiki.fnal.gov/wiki/Main_Page

Have added events back to 2020, so a “complete” resource for links to our meetings and external talks.

- Let me know if something is missing, or feel free to edit yourself

July 2021

Su		Tu	We	Th	Fr	Sa
				1	2	3
4	5	6 Tracker	7 Tracker workshop - postponed	8 Accelerator	9 DPF practice	10
11	12 Convenors; DPF meeting start	13	14	15 Accelerator	16	17
18	19	20 Tracker	21 Mu2e-II workshop	22	23	24
25	26	27	28	29 Accelerator	30	31

Clicking on date provides details of events for that day

Main Page/2021-07-21

Contents [hide]

- 1 Mu2e-II Snowmass22 Workshop (ix)
 - 1.1 DocDB entry
 - 1.2 Indico page with agenda and talks
 - 1.3 Zoom link
 - 1.4 Meeting recording

Mu2e-II Snowmass22 Workshop (ix) [edit]

Wednesday, July 21, 2021, 10AM to 2PM CT

DocDB entry [edit]

<https://mu2e-docdb.fnal.gov/cgi-bin/sso/DisplayMeeting?conferenceid=11444>

Indico page with agenda and talks [edit]

<https://indico.fnal.gov/event/49360/>

Zoom link [edit]

Frank C. Porter is inviting you to a scheduled Zoom meeting.

Topic: Mu2e-II Snowmass21 Workshop (ix) Time: Jul 21, 2021 10:00 AM Central Time (US and Canada)

Join Zoom Meeting <https://caltech.zoom.us/j/82754823698>

Thinking about “when”

View from 2020 European Strategy Physics input on CLFV

<https://arxiv.org/pdf/1812.06540.pdf>

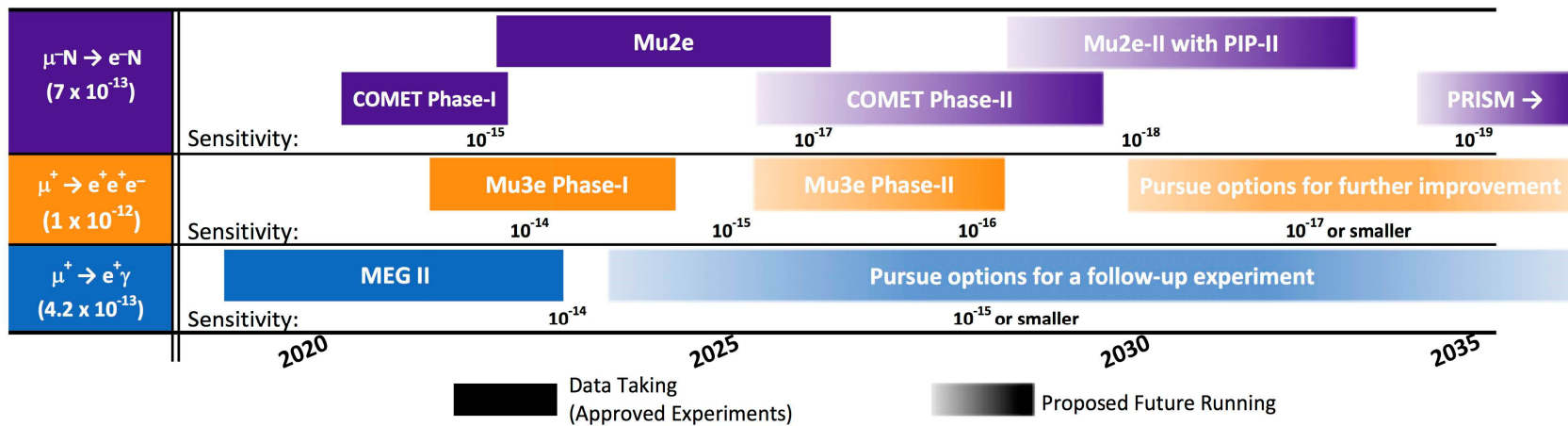

- Nice overview, but already wrong when it appeared (not only for Mu2e)
- Latest Mu2e is “Project Complete” April 2024 (R.Ray, DocDB-38699)

Thinking about “when”

FNAL draft long-range plan (Jan 2021, excluding accompanying notes)

<https://ppp-docdb.fnal.gov/cgi-bin/sso/RetrieveFile?docid=724&filename=10yr-PLAN-Current.pdf>

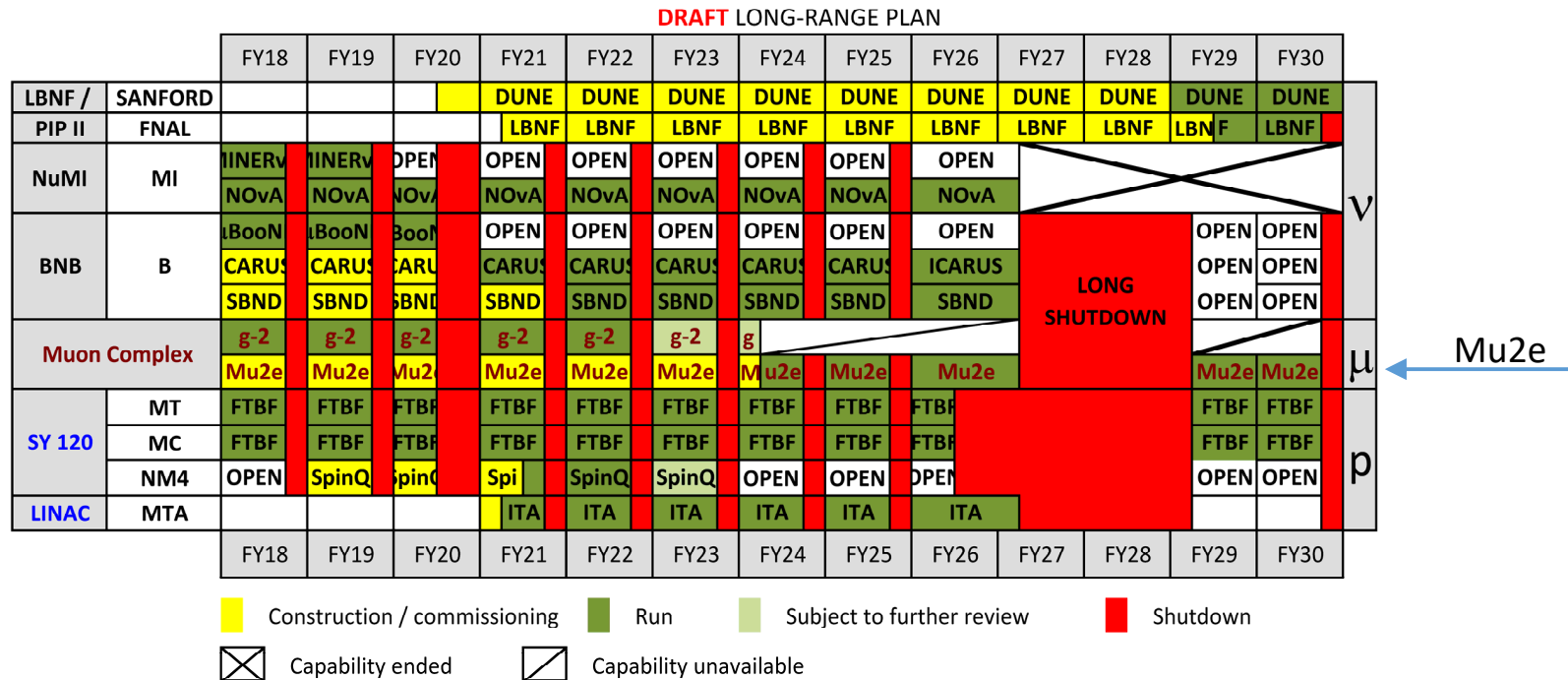

Shows Mu2e running until end of FY30

Shows PIP-II operation beginning mid FY29 (PIP-II CD4 December 2028)

Thinking about “when”

If Mu2e runs until end of 2030, when does Mu2e-II run?

- Mu2e experience useful to have in designing Mu2e-II
- Significant construction could happen in parallel with Mu2e run, long shutdown
- Major installation cannot begin until Mu2e is complete
 - Except perhaps portions of beamline from PIP-II
- Sticky question: When/how can work happen in PS area?
 - Residual radiation

Thinking about “when”

Residual dose at production solenoid

- 365 days irradiation
- 8 GeV
- 8 kW
- after 1 week cooldown
- mid-plane of PS

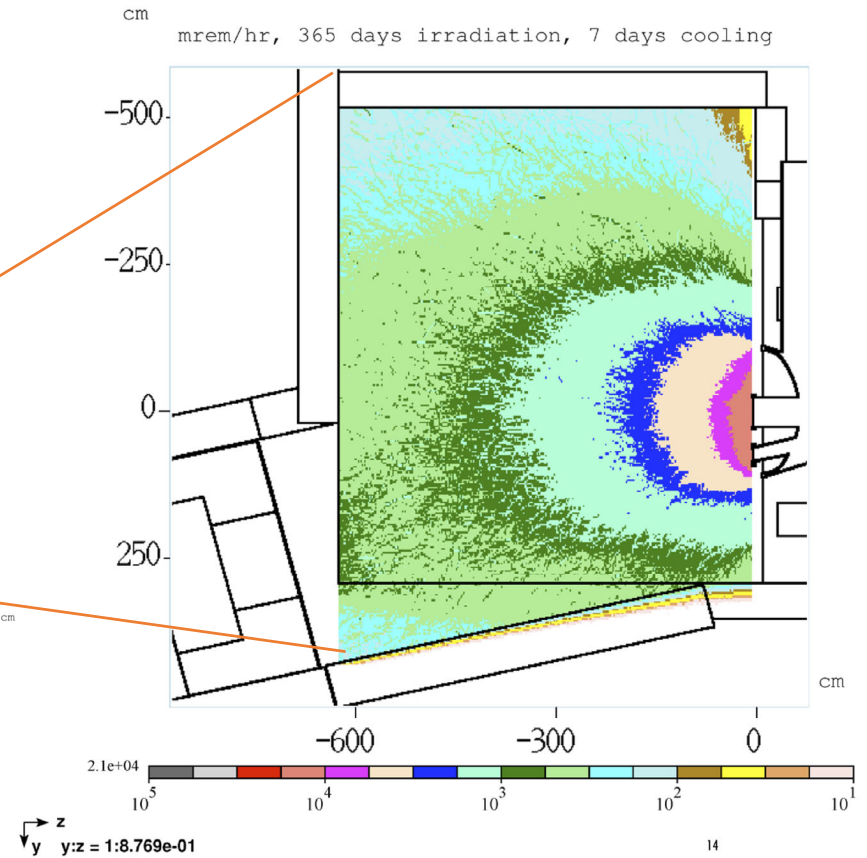
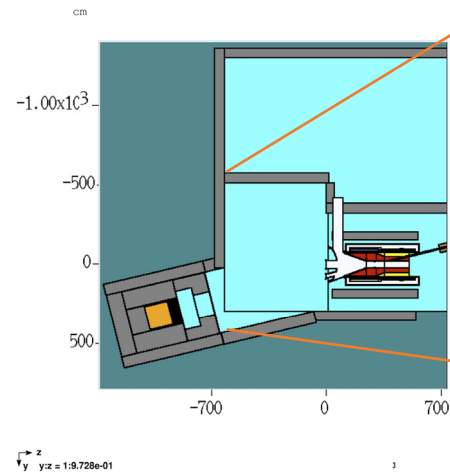

Hottest point in this region: 21 rem/hr

DocDB-5629 (Leveling)

See also:

<https://www.sciencedirect.com/science/article/abs/pii/S0168900217309415> (FermiCORD paper)

July 21 Mu2e-II workshop agenda

[Indico timetable at: https://indico.fnal.gov/event/49380/](https://indico.fnal.gov/event/49380/)

When (CT)	Who	What
10:00-10:25	Frank Porter	Introduction
15	Craig Dukes	Cosmic ray veto
15	Antonio/Giani	TDAQ
25	Mary Anne Cummings	Alternate beam delivery
25	Eric Prebys	Accelerator – Proton economics
15	David Hitlin	Calorimeter
12:00-12:30	All	Break
20	Vitaly Pronskikh	Radiation studies
25	Yuri Oksuzian	Sensitivity
25	Julian Heeck	Theory
20	Daniel Ambrose	Tracker
14:00	All	End

Additional Material

Mu2e-II Working Groups

Mu2e-II working groups	Convenors
Theory mu2eii-theory@fnal.gov	Lorenzo Calibbi Julian Heeck
Accelerator (including PS, production target, extinction) mu2e-ii-accelerator@fnal.gov	Karie Badgley David Neuffer Eric Prebys
Radiation mitigation (includes radiation simulation) mu2eii-radiation@fnal.gov	Michael MacKenzie Stefan Mueller Vitaly Pronskikh
Tracker mu2eii-tracker@fnal.gov	Daniel Ambrose Giovanni Tassielli
Calorimeter (and STM?) mu2eii-calorimeter@listserv.fnal.gov	David Hitlin Luca Morescalchi Ivano Sarra
CRV mu2eii-crv@listserv.fnal.gov	Craig Dukes Yuri Oksuzian
Sensitivity estimate (includes simulation, stopping target) mu2e-ii-sensitivity@listserv.fnal.gov	Lisa Goodenough Sophie Middleton Yuri Oksuzian
Trigger and DAQ mu2eii-tdaq@listserv.fnal.gov	Antonio Gioiosa Giani Pezzullo

Muon stops

Quantity	Mu2e	Mu2e-II (nominal)	Units
Stopped μ /POT	1.5×10^{-3} (37571)*	8.9×10^{-5} (37571)	
Beam kinetic energy	8000	800	MeV
Beam power	8	100	kW
POT (3 yr)	3.6×10^{20} (12014)	4.5×10^{22}	
Stopped μ	5.4×10^{17}	4.0×10^{18}	
SES	3.7×10^{-17} (12014)*		

numbers in () are DocDB references

POT = Protons On Target
SES = Single Event Sensitivity

$$\text{POT} = 3 \text{ yr} \times 1.92 \times 10^7 \text{ (s/yr)} \times \text{power(W)} / \text{Ebeam(J)}$$

*DocDB 7464 says 0.00187 stopped μ /POT (corresponds to SES 3×10^{-17});
SES here is scaled from this using 0.0015 stopped μ /POT

$$\text{Stopped } \mu \text{(Mu2e-II)} / \text{Stopped } \mu \text{(Mu2e)} = 40 / 5.4 = 7.4$$

Muon stops

This means that for a SES of 10x better than Mu2e, or $SES = 3.7 \times 10^{-18}$, the beam power should be 135 kW

In other words,

$$SES(\text{Mu2e-II}) = 5 \times 10^{-18} \times \frac{100 \text{ kW}}{P}$$

(We assume the efficiency to observe a conversion electron is the same in Mu2e-II as in Mu2e)

Comment: These are early results and will change!

Thinking about “when”

<https://www.sciencedirect.com/science/article/abs/pii/S0168900217309415>

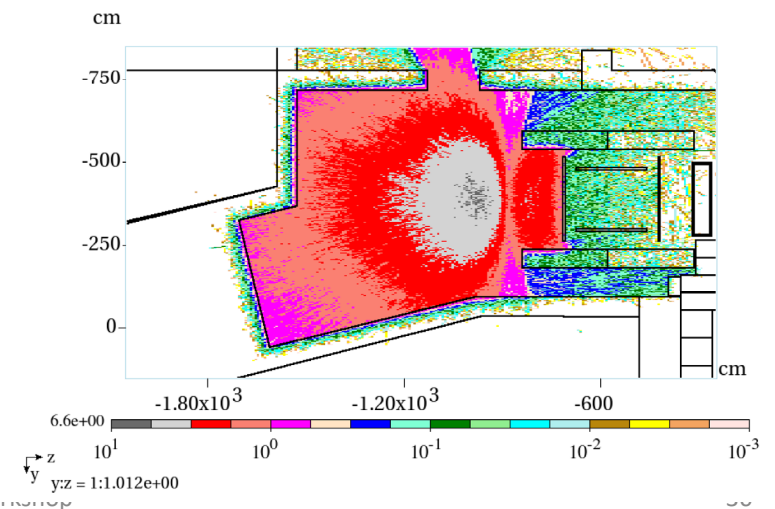
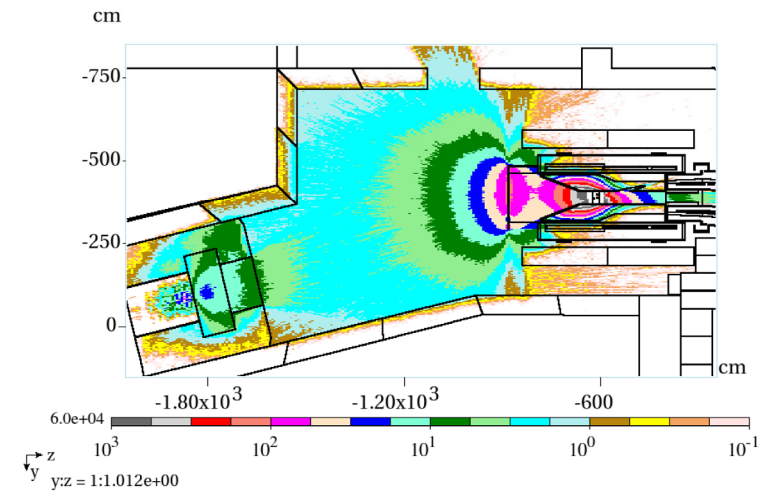

7/21/2021

F. Porter - Mu2e Snowmass21 workshop

Snowmass 22 Planning – “covid pause”

January Snowmass newsletter:

https://indico.fnal.gov/event/47394/attachments/139229/175180/Snowmass_Newsletter_Jan.2021.pdf

<https://snowmass21.org/announcements>

- **High-level activities on hold until the end of June 2021**
 - Includes Frontier-level and Topical Group-level workshops, All-conveners meetings, Advisory Group meetings and Newsletters.
- **Other Topical Group and cross-frontier activities paused or reduced to a significantly lower level, proceeding only as necessary to ensure:**
 - scientific continuity
 - meet essential programmatic needs
 - maintain collaborative work with other units and communities
- No critical decisions will be made during the hiatus
- No individuals obligated to participate in these activities
- **Individual, collaborative and self-organized work can continue at the discretion of the individuals involved**

Snowmass 22 - Endgame Schedule

- **White Paper submission to arXiv: no later than March 15, 2022**
 - Late submissions and updates unlikely to be incorporated in the working group reports
- Preliminary reports by the Topical Groups due: no later than May 31, 2022
- Preliminary reports by the Frontiers due: no later than June 30, 2022
- Snowmass Community Summer Study (CSS): July 2022 at UW-Seattle
- Final reports by Frontiers due: no later than September 30, 2022
- Snowmass Book and on-line archive documents due: October 31, 2022

Contributed Paper – Proposed Top Level Outline

- I. Overview
 - II. Theory
 - III. Accelerator and beam line
 - IV. Production target and environment
 - V. Solenoids
 - VI. Radiation
 - VII. Tracking
 - VIII. Calorimetry
 - IX. Cosmic ray veto
 - X. Trigger and Data Acquisition
 - XI. Physics sensitivity
- References

Proposed Mu2e-II beam nomenclature

- Follow accelerator group usage
- Beam delivery is different than Mu2e

Quantity	Name
Beam in one PIP-II RF bucket (162.5 MHz)	Bunch
PIP-II pulse (20 Hz/0.55 ms)	Pulse (but see below)*
Mu2e-II repetition (e.g., 1693 ns)	Spill (also pulse, but see above)**
Set of bunches in one spill (e.g., 8)	Burst (also pulse, but see above)**

*One PIP-II pulse is about 27770 Mu2e-II spills; suggest saying “PIP-II pulse” to avoid confusion.

**“Pulse” may be used when distinction is not important

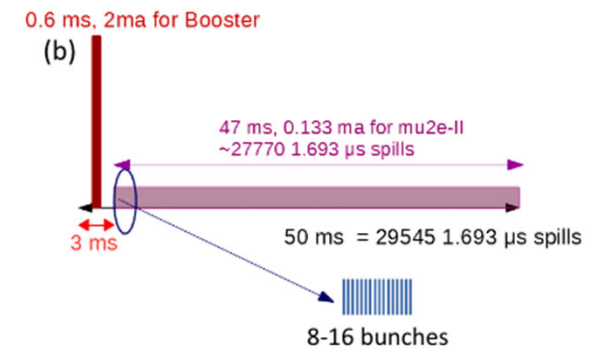
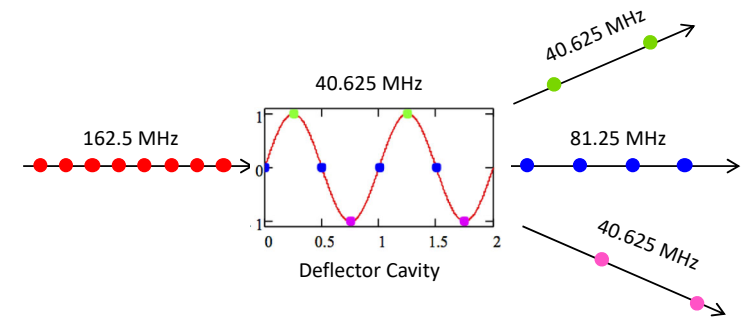

Eric Prebys

<https://indico.fnal.gov/event/44997/>

David Neuffer, DocDB 33896

Mu2e-II Snowmass21 Committee

Name	Institution	Email
Dan Ambrose	U Minn	ambrose0028@gmail.com
Rebecca Chislett	UC London	rebecca.chislett@ucl.ac.uk
Lisa Goodenough	FNAL	goodenou@fnal.gov
Julian Heeck	U Virginia	julian.heeck@gmail.com
David Neuffer	FNAL	neuffer@fnal.gov
Yuri Oksuzian	ANL	yoksuzian@anl.gov
Frank Porter (chair)	Caltech	fcp@caltech.edu
Giovanni Tassielli	INFN-Lecce	giovani.tassielli@le.infn.it
Robert Bernstein (ex officio)	FNAL	rhbob@fnal.gov
Jim Miller (ex officio)	Boston U	miller@bu.edu