



# Challenges and Lessons Learned from fabrication, test and analysis of ~10 MQXFA Low Beta Quadrupoles for HL-LHC

Giorgio Ambrosio and the MQXFA team

ASC  
22

RIDE  
THE  
WAVE

HONOLULU  
OCTOBER  
23-28

HAWAII  
CONVENTION  
CENTER

# Acknowledgement

- **US HL-LHC Accelerator Upgrade Project (AUP)**
  - **BNL:** K. Amm, M. Anerella, A. Ben Yahia, H. Hocker, P. Joshi, J. Muratore, J. Schmalzle, H. Song, P. Wanderer
  - **FNAL:** G. Ambrosio, G. Apollinari, M. Baldini, J. Blowers, R. Bossert, R. Carcagno, G. Chlachidze, J. DiMarco, S. Feher, S. Krave, V. Lombardo, C. Narug, A. Nobrega, V. Marinozzi, C. Orozco, T. Page M. Parker, S. Stoynev, T. Strauss, M. Turenne, D. Turrioni, A. Vouris, M. Yu
  - **LBNL:** D. Cheng, P. Ferracin, L. Garcia Fajardo, E. Lee, M. Marchevsky, M. Naus, H. Pan, I. Pong, S. Prestemon, K. Ray, G. Sabbi, G. Vallone, X. Wang
  - **NHMFL:** L. Cooley, J. Levitan, J. Lu, R. Walsh
- **CERN: HL-LHC Project**
  - G. Arnau Izquierdo, A. Ballarino, M. Bajko, C. Barth, N. Bourcey, B. Bulat, M. Cruovizier, A. Devred, H. Felice, S. Ferradas Troitino, L. Fiscarelli, J. Fleiter, M. Guinchard, O. Housiaux, S. Izquierdo Bermudez, N. Lusa, F. Mangiarotti, A. Milanese, A. Moros, P. Moyret, C. Petrone, J.C. Perez, H. Prin, R. Principe, E. Ravaioli, T. Sahner, S. Sgobba, P. Tavares Coutinho Borges De Sousa, E. Todesco, J. Ferradas Troitino, R. Van Weelderen, G. Willering

# Outline

- MQXFA magnets
- Fabrication and test status
- Analysis of magnets with limited performance
- Lessons learned and corrective actions
- MQXFA endurance and resilience
- Conclusions

# US Contribution to HL-LHC



From HL-LHC Project Leader  
O. Bruning - CERN

Quad Magnets

$$L = \gamma \frac{f_{rev} n_b N_b^2}{4\pi \epsilon_n \beta^*} R$$

Beam size

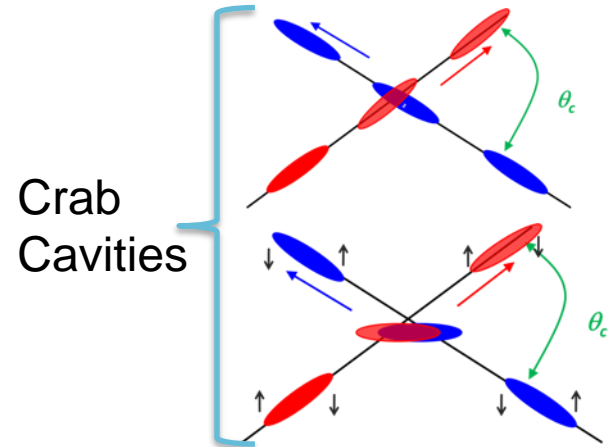

- HL-LHC: from 300 fb<sup>-1</sup> to 3000/4000 fb<sup>-1</sup>
- LARP (DOE supported R&D Program) established the necessary technology for the HL-LHC Focusing Magnets and Crab Cavities
- DOE baselined **HL-LHC Accelerator Upgrade Project (AUP)**, coordinating efforts from US Labs (FNAL, BNL, LBNL with contributions from SLAC, JLAB, ODU & FSU)

Slide by G. Apollinari



# 20 MQXFA Magnets for HL-LHC Inner Triplets

- 10 Q1/Q3 Cryo-assemblies (including 2 spares)
- 2 magnets in each cryo-assembly

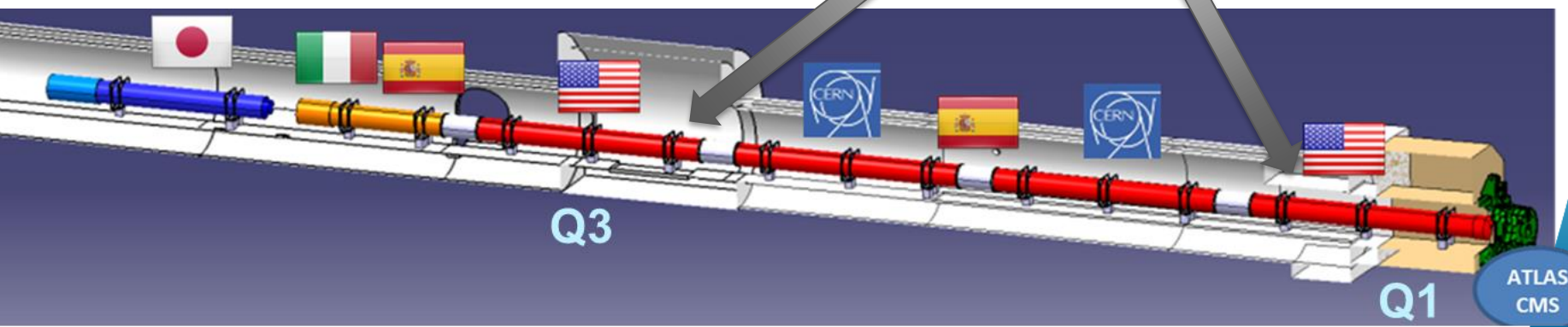
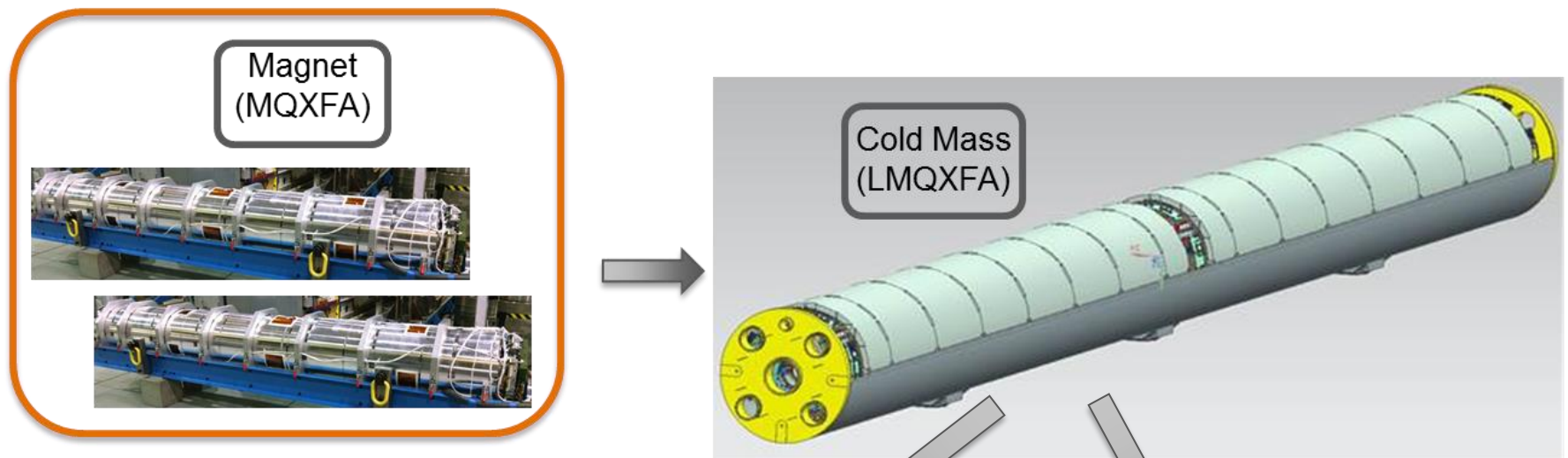

# MQXFA/B Design

PARAMETER	Unit	MQXFA/B
Coil aperture	mm	150
Magnetic length	m	4.2/7.15
N. of layers		2
N. of turns Inner-Outer layer		22-28
Operation temperature	K	1.9
Nominal gradient	T/m	132.2
Nominal current	kA	16.23
Peak field at nom. current	T	11.3
Stored energy at nom. curr.	MJ/m	1.15
Diff. inductance	mH/m	8.26
Strand diameter	mm	0.85
Strand number		40
Cable width	mm	18.15
Cable mid thickness	mm	1.525
Keystone angle		0.4

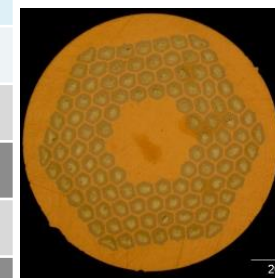
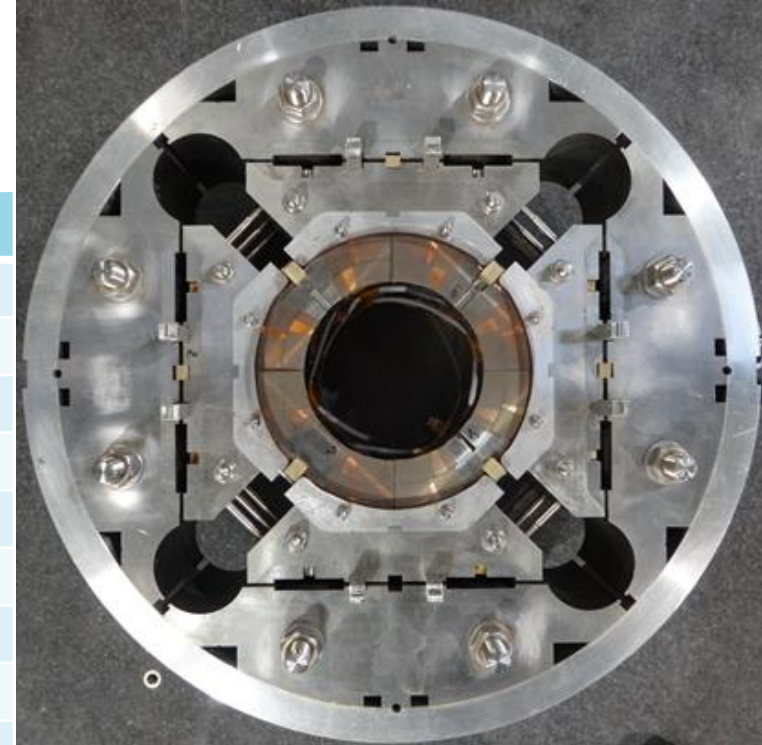

Nb<sub>3</sub>Sn Conductor  
RRP 108/127

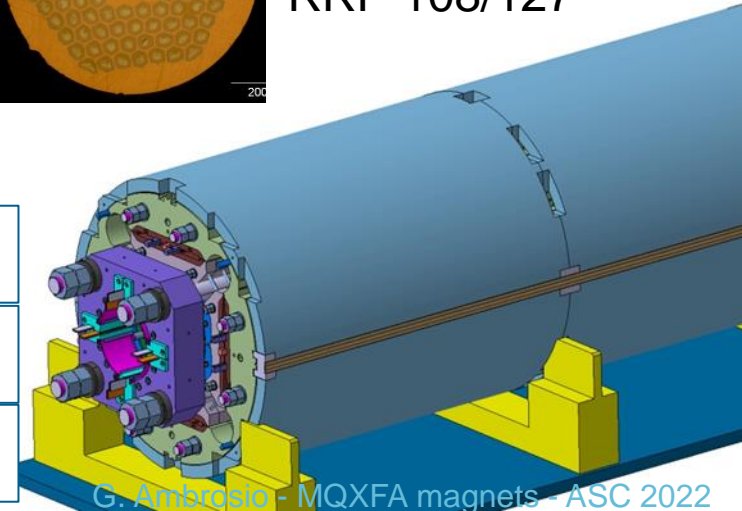

P. Ferracin et al., "Development of MQXF, the Nb<sub>3</sub>Sn Low-β Quadrupole for the HiLumi LHC" IEEE Trans App. Supercond. Vol. 26, no. 4, 4000207

G. Ambrosio et al., "First Test Results of the 150 mm Aperture IR Quadrupole Models for the High Luminosity LHC" NAPAC16, FERMILAB-CONF-16-440-TD

E. Takala et al., "Mechanical Comparison of Short Models of Nb<sub>3</sub> Sn Low-β Quadrupole for the Hi-Lumi LHC" IEEE TAS. Vol. 31, no. 5, 4000306

# MQXFA Fabrication Status I

- Conductor: **2560 Km** received out of 2660 Km
- Cables: **97** fabricated out of 109 (**89%**)
  - Yield is 91.9%
- Coils: **83** fabricated out of 102 (**81%**)
  - Fabrication yield is 85.5%
  - Yield after magnet assembly & test is 78.9%

Conductor verification and test at FNAL & FSU  
Cabling at LBNL  
Coil parts procurement at FNAL  
Coil fabrication at BNL & FNAL  
Structure procurement & Magnet assembly at LBNL



## MQXFA Fabrication Status II

- 9 magnets have been assembled: MQXFA03-11
- 1 magnet has been disassembled after preload
  - MQXFA09
- 8 magnets have been tested
  - MQXFA03-08 and MQXFA10-11
- 1 magnet has been dis-assembled after test & re-assembled with a new coil
  - MQXFA08 → MQXFA08b

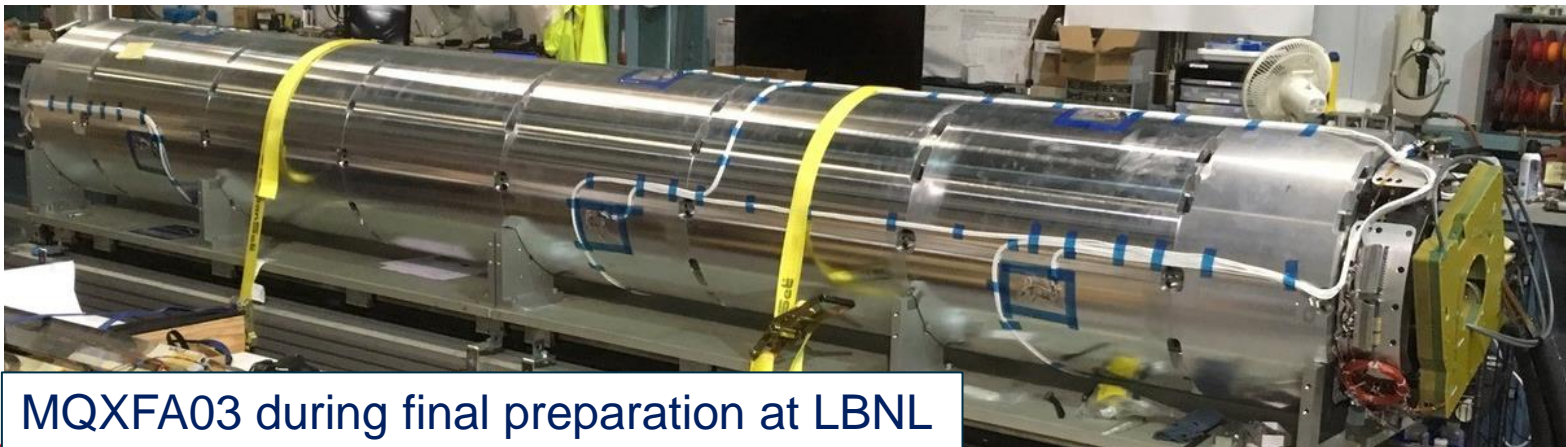

MQXFA03 during final preparation at LBNL



# MQXFA Vertical Test

- MQXFA magnets are vertically tested at BNL
- Test plan demonstrates:
  - Holding at **Acceptance Current**: Nominal + 300 A
  - Temperature margin**: Nominal curr. at 4.5 K
  - Memory after thermal cycle**
  - Other requirements (next slide)

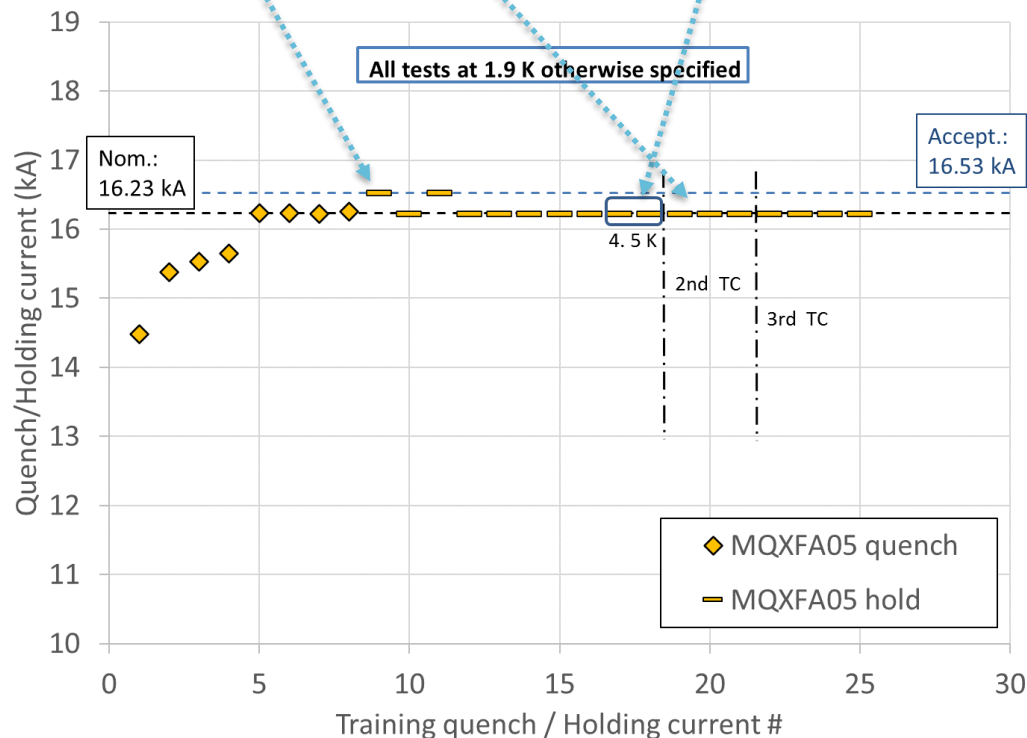

# Vertical Test Summary

- Magnets are accepted for use in LMQXFA Cold Mass if they meet all Vertical Test Requirements
  - Hold current at nominal current + 300 A ✓
  - Field Quality ✓
  - Integrated gradient ✓
  - Ramp to/from  $I_{\text{nom}}$  at  $\pm 30$  A/s ✓
  - 100 A/s ramp down w/o quench (max for power supply) ✓
  - Temperature margin ✓
  - Training memory ✓
  - Splice resistance (less than 1 n $\Omega$ ) ✓
  - All electrical requirements ✓

S. Feher et al., "AUP first pre-series Cryo-Assembly Design Production and Test Overview" **2L0r2A-04**

# Vertical Test: Training

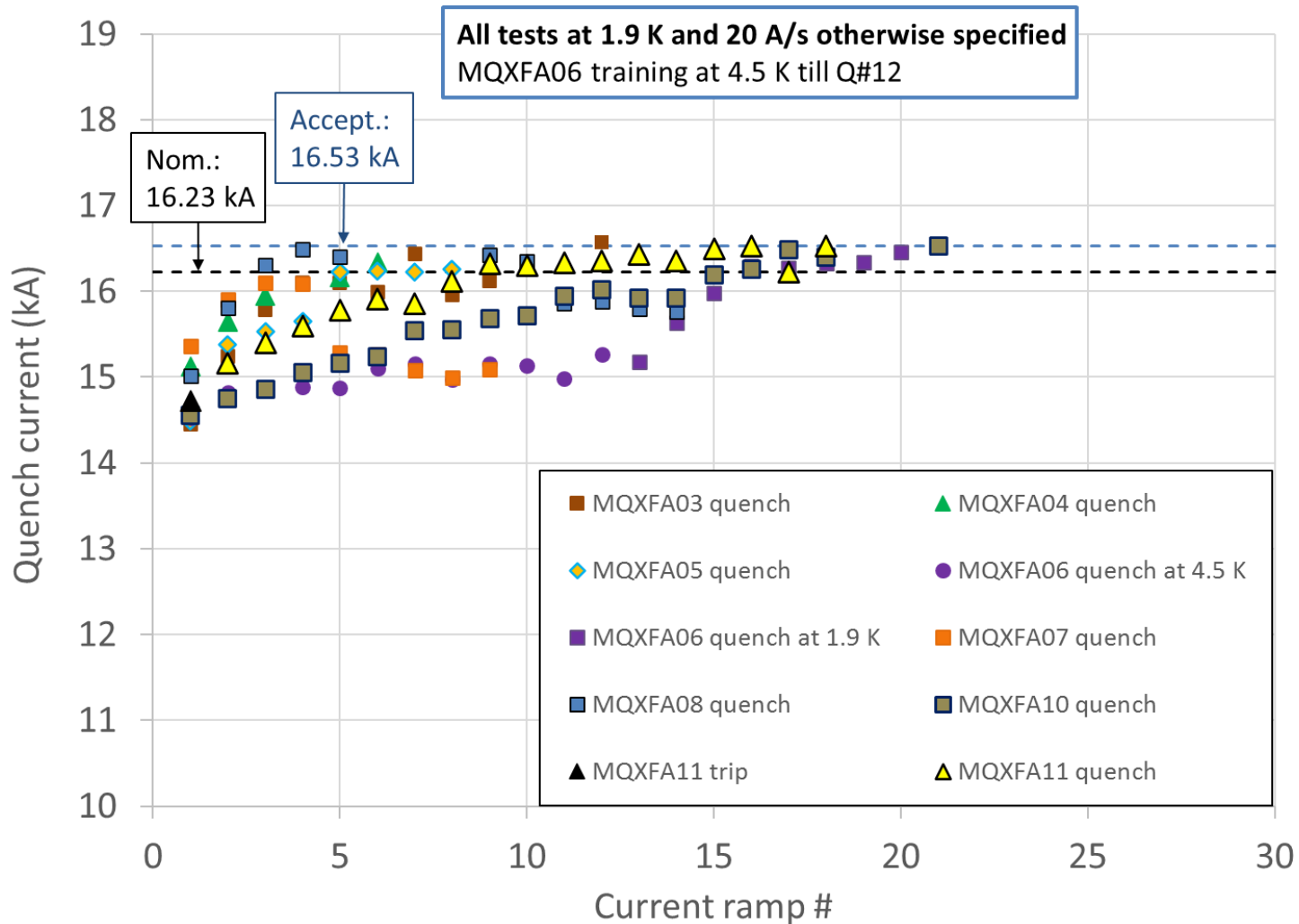

- MQXFA03-06 and MQXFA10-11 reached and held Acceptance Current and met all requirements tested at BNL  
6 out of 8 magnets tested

# Integrated Gradient & Field Quality @ BNL

Courtesy of G. Sabbi and A. Ben Yahia

## Field Quality in Straight Section vs expectation

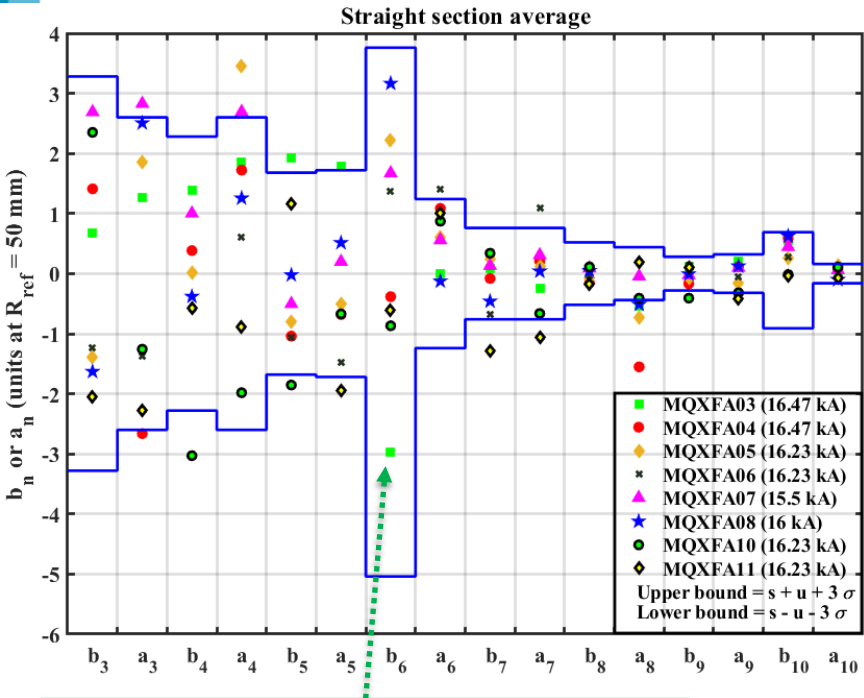

Before b6 correction in cross-section

## Integrated Gradient Variations in MQXFA Models

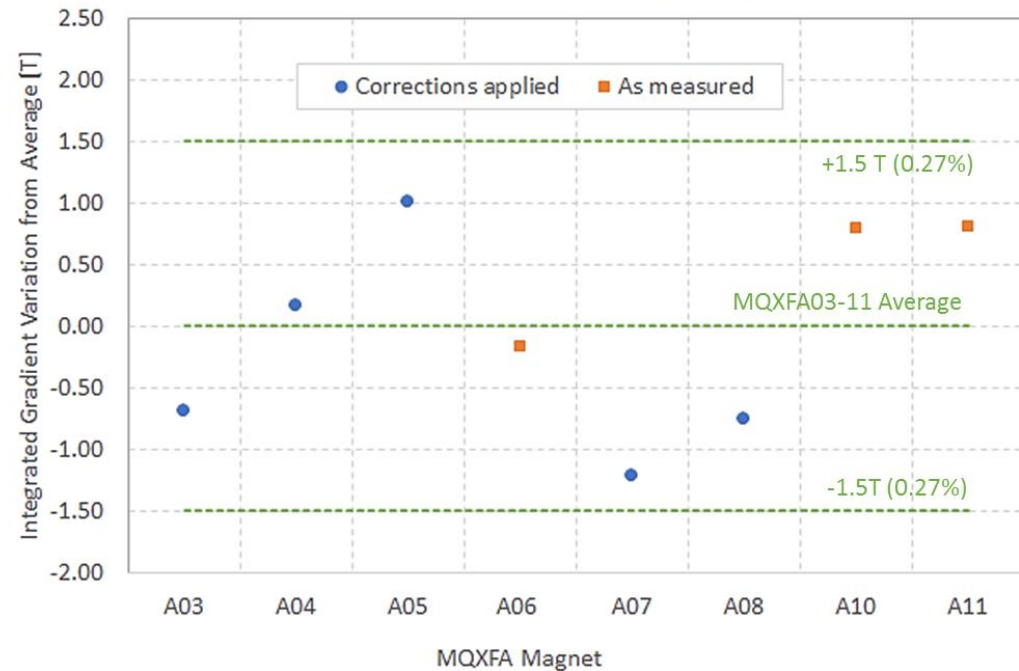

**Average IG at 16.23 kA: 561.92 T**  
 In order to obtain a consistent comparison, correction factors were applied to several magnets to account for measurements taken at different currents as well as changes in the measurement setup and coil design

## Mechanical data and analysis:

L. Garcia Fajardo et al., "Analysis of the mechanical performance of the 4.5 m long MQXFA Pre-Series magnets for the Hi-Lumi LHC Upgrade" **3LPo1A-01**



# Outline

- MQXFA magnets
- Fabrication and test status
- Analysis of magnets with limited performance
  - MQXFA07 and MQXFA08
- Lessons learned and corrective actions
- MQXFA endurance & resilience
- Conclusions



US-HiLumi-doc-4293  
CERN EDMS 2777612

G. Ambrosio - MQXFA magnets - ASC 2022

	<p><b>Analysis of MQXFA07 Test Non-Conformity</b></p>	<p>US-HiLumi-doc-4293 Other: Date: Sept. 12, 2022 Page 1 of 43</p>
<div style="text-align: center;">  <p><b>US HL-LHC Accelerator Upgrade Project</b></p> <p><b>Analysis of MQXFA07 Test Non-Conformity</b></p> <p>Editors: G. Ambrosio, M. Baldini, P. Ferracin</p> <p><small>G. Ambrosio, M. Anerella, G. Arnau Izquierdo, M. Baldini, A. Ballerino, C. Barth, A. Ben Yahia, J. Blowers, B. Bulat, D. Cheng, L. Cooley, M. Crouvizier, A. Devred, J. DiMarco, S. Feher, P. Ferracin, L. Garcia Fajardo, S. Izquierdo Bermudez, Elizabeth M. Lee, V. Lombardo, V. Marinuzzi, A. Moros, M. Naus, A. Nobrega, I. Pong, S. Prestemon, K. Ray, G. Sabbi, J. Schmalzle, S. Sgobba, E. Todesco, M. Turenne, G. Vallone, M. Yu, X. Wang</small></p> </div>		

# MQXFA07 Training Quenches

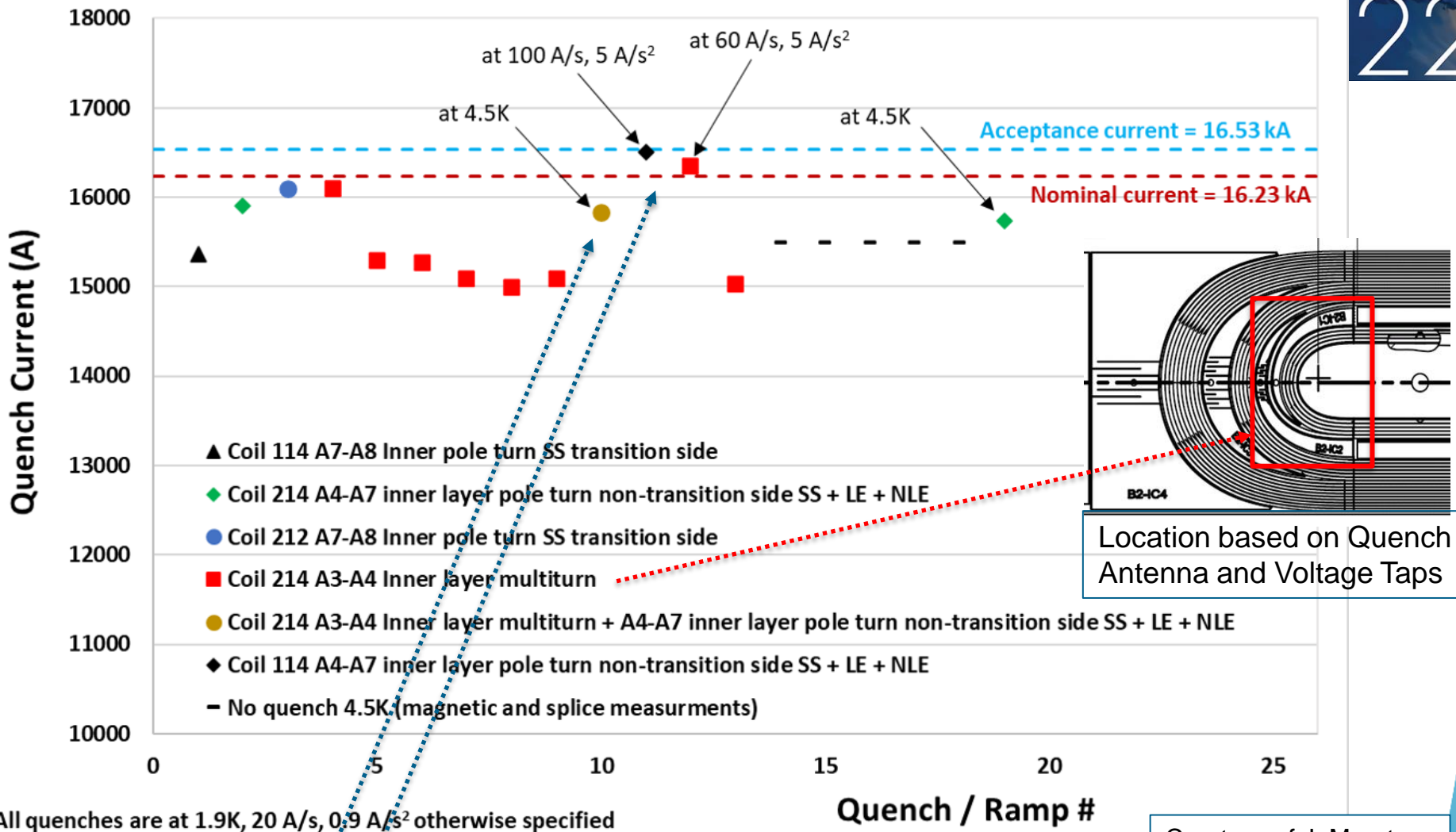

Courtesy of J. Muratore and A. Ben Yahia

- Reverse temperature dependence
- Reverse ramp-rate dependence
- Same features and location in MQXFA08

## Limitation “Mechanism”

- Self-field **instability** triggered by a **local issue**, likely affecting only some strands, that pushes more current in adjacent strand(s)
  - Field in quenching turn is between 6 and 9 T

B. Bordini, et al., IEEE Trans. Appl. Super., vol. 22, 2012, # 4705804  
A. K. Ghosh, IEEE Trans. Appl. Super., vol. 23, 2013, # 7100407

- Similar mechanism in other magnets:
  - MQXFS03 showed a reversible component

H. Bajas et al., “Test Results of the Short Models MQXFS3 and MQXFS5 for the HL-LHC Upgrade”, IEEE Trans. Appl. Super. Vol 28, # 4007006 (2018)

- LARP Long Quadrupole #2 showed “enhanced thermo-magnetic instability” in mid-plane block
- With flux jumps

Ref: G. Ambrosio et al., “Progress in the Long Nb<sub>3</sub>Sn Quadrupole R&D by LARP”, IEEE Trans Appl, Superc. Vol 22, # 4003804 (2012)

# Coil Fabrication Analysis

- A few discrepancies during fabrication:
  - Some strands popped out during winding, were fixed, popped out overnight and were fixed a second time (BNL DR AM-164)
  - Limiting coil was affected by COVID lockdown
    - 14 weeks stop after winding & curing of inner layer
  - No other NCR nor traveler data anomaly

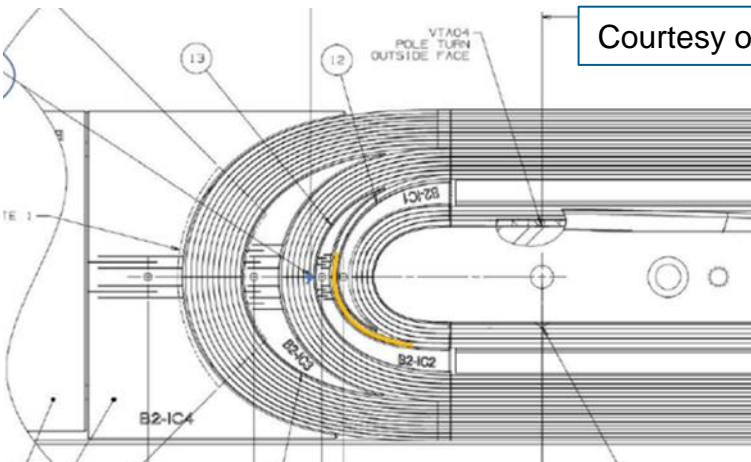

Courtesy of J. Schmalzle



Inner layer coil showing in yellow  
the position of coil-214 cable  
affected by DRAM-164

coil 214 as it was setup for the lab shutdown



# Structure Analysis & MQXFA07 Disassembly

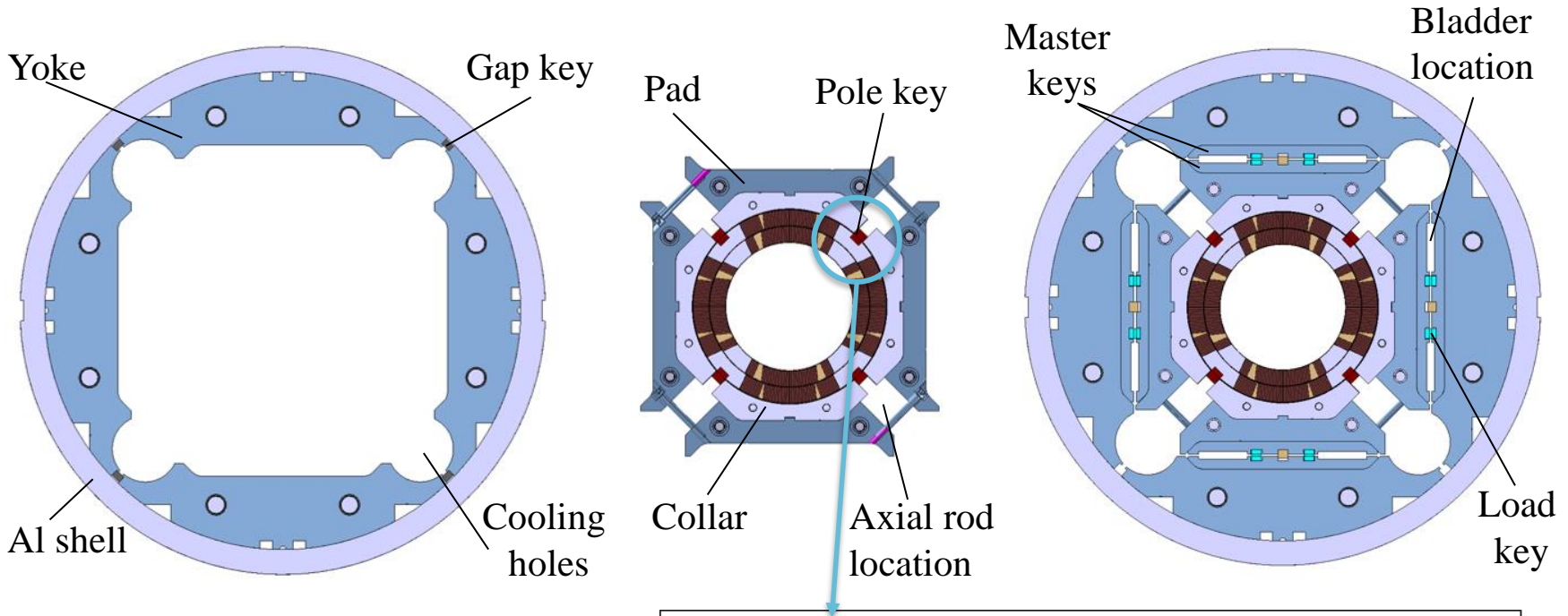

A pole-key gap asymmetry was found during MQXFA07 and MQXFA08 disassembly:

- Gaps closed in quadrant 3
- Gaps open in other quadrants

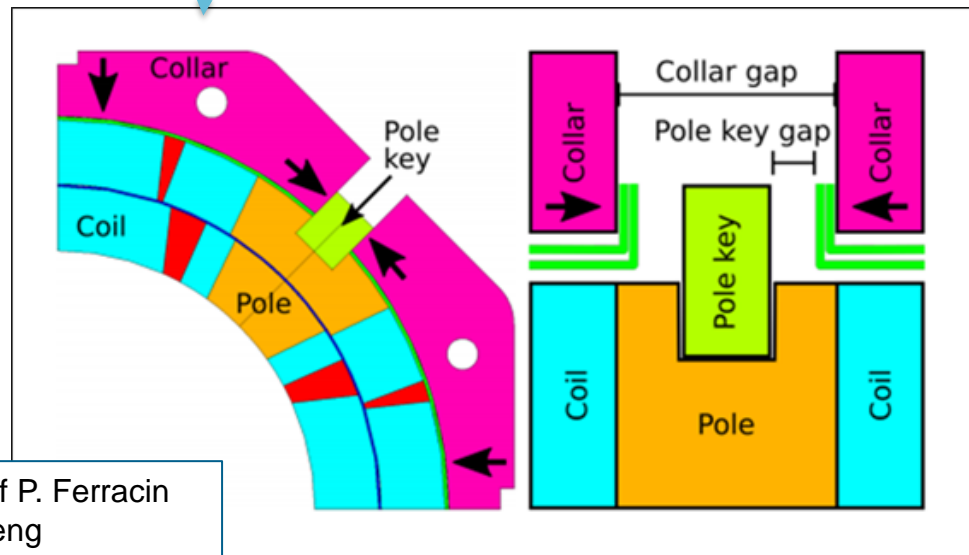

Courtesy of P. Ferracin and D. Cheng

# Pole-key gaps in MQXFA07

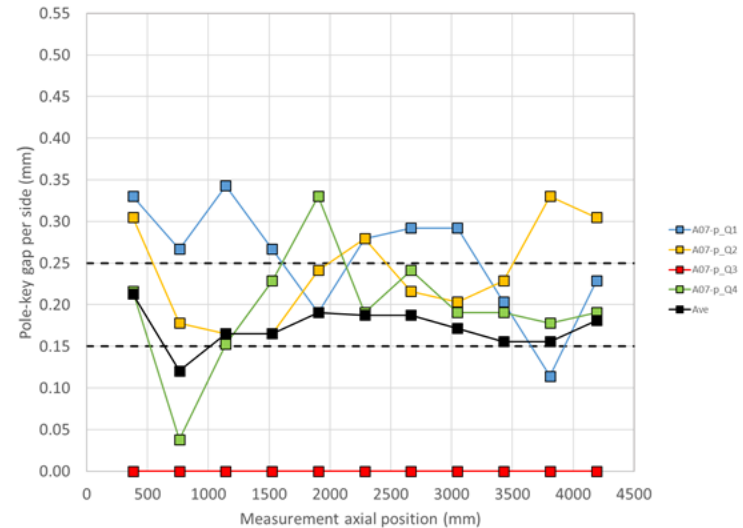
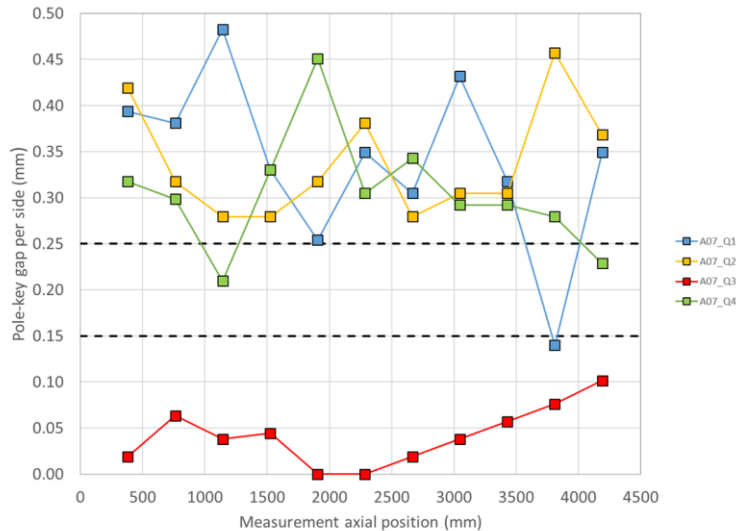

- The measured **pole-key gaps** were not as **uniform** in MQXFA07 and MQXFA08 as in past magnets; this is particularly apparent on the **limiting coils (Q3 for both magnets)**
- Only the **total average** (on the 4 keys) was targeted in the **specification**. The underlying assumption was that the **gaps** would be **redistributed** across coils during **loading**.
- **Investigation** of the effect of this non-uniformity on the mechanical performances with **2D** and **3D FE models**
  - **2D effect: preload variation within acceptable range**



# Possible Damage at Wedge-Spacer Interface

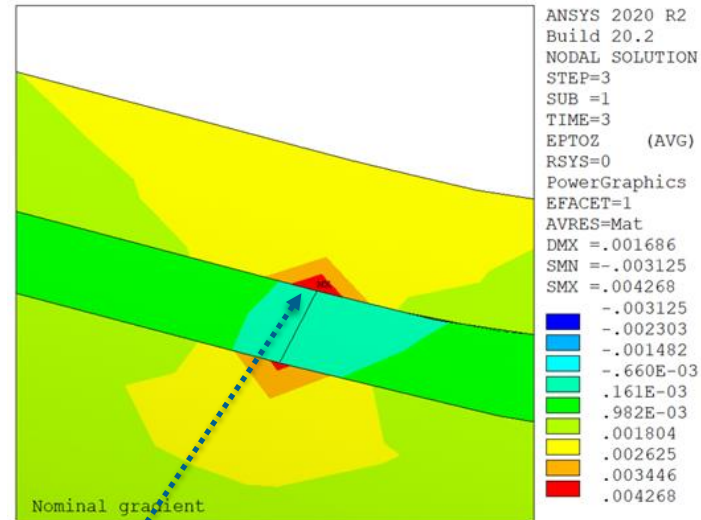
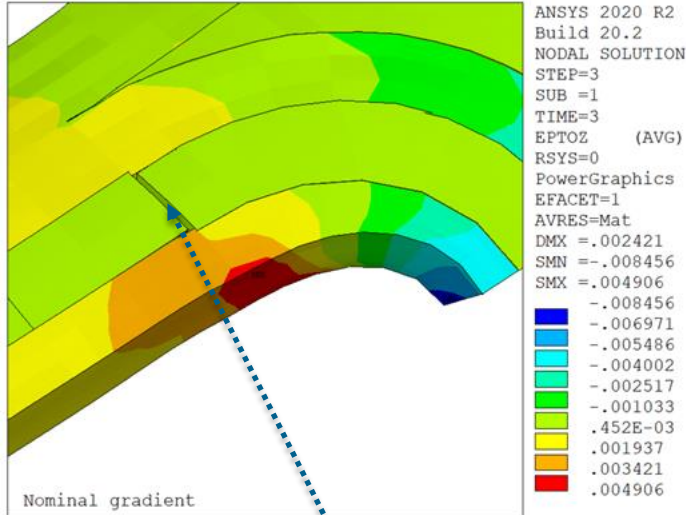

- At cold the coil with less azimuthal preload ends up with **less longitudinal preload**
- At nominal current tension develops between the inner wedge and the end spacer, and a (small) **gap** may open
- This may result in high **longitudinal strain** (up to **0.4%**) in that location
  - This location is consistent with quench data
  - Effect is larger on the pole block, but also visible on the mid plane block



Courtesy of G. Vallone  
and P. Ferracin

# Micrographic Analysis of Coil 214 Lead End

CT-scan, dye-penetrant test and metallurgical analysis by **CERN teams**  
**OUTSTANDING!**

S. Sgobba et al., “Advanced Examination of Nb<sub>3</sub>Sn Coils and Conductors for the LHC luminosity upgrade: Computed Tomography and Materialographic Analyses”, **this session**

Analysis started with sample #1: wedge-spacer interface

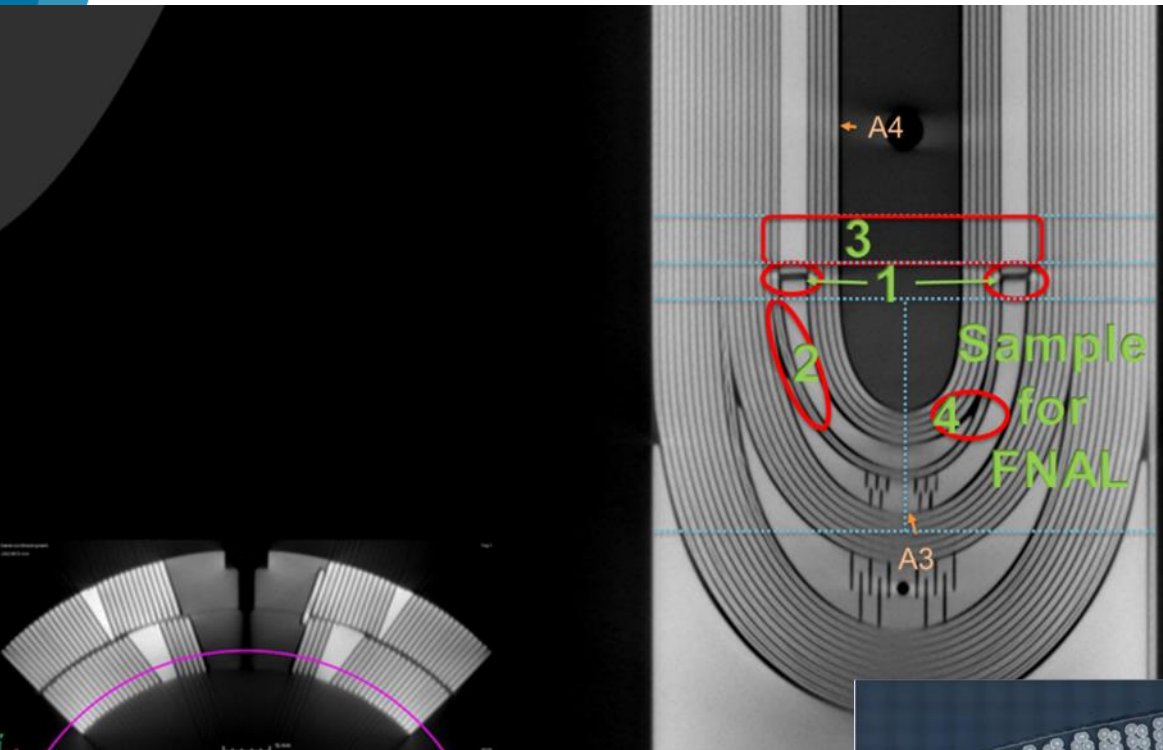

By B. Bulat, CERN

No anomalies found in cross-section #1. Therefore, we did **longitudinal sections**

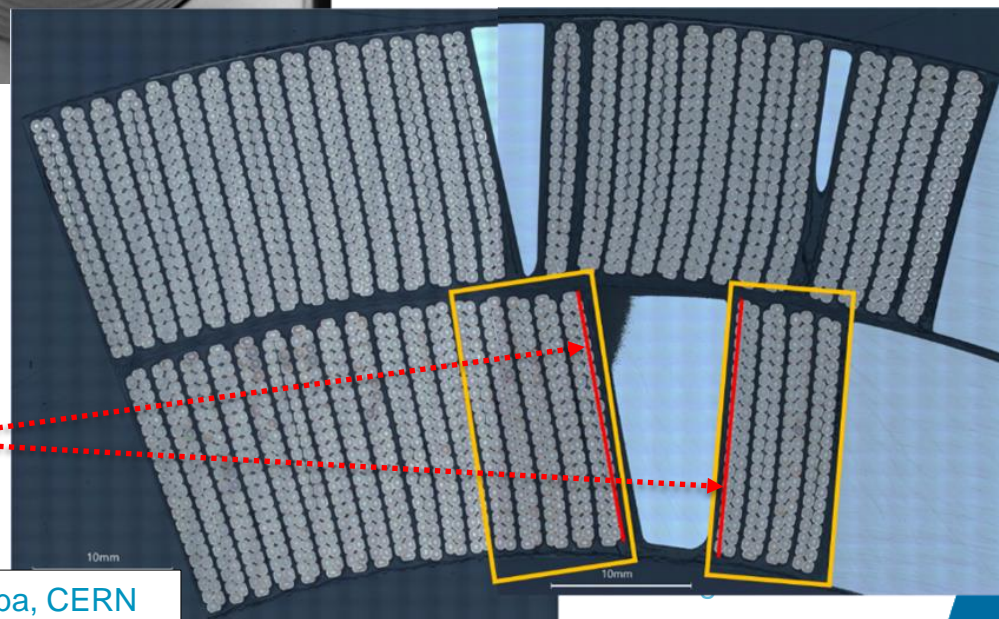

By M. Crouvizier, A. Moros, S. Sgobba, CERN

# Metallurgical inspection: the smoking gun!

- Longitudinal cuts on cables adjacent to the end-spacer/copper-wedge transition
  - Localized field of **broken filaments (red dots)**, especially at pole block

By M. Crouvizier, A. Moros, S. Sgobba, CERN

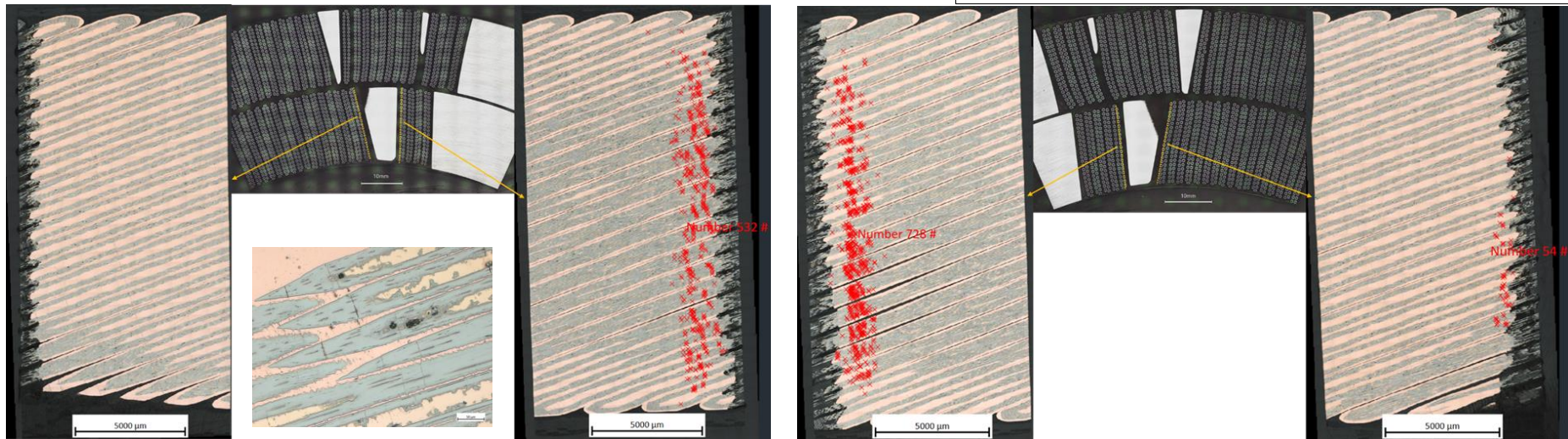

#	Samples adjacent to W-S transition from coil 214 Lead End	Number of cracked filaments
1	Layer-jump side, cable in midplane block, side adjacent to W-S transition	0
2	Layer-jump side, cable in <b>pole block</b> , side adjacent to W-S transition	<b>532</b>
3	Non-layer-jump side, cable in midplane block, side adjacent to W-S transition	54
4	Non-layer-jump side, cable in <b>pole block</b> , side adjacent to W-S transition	<b>728</b>
5	Same cable of sample 4, side opposite to the W-S transition	0

# MQXFA08 Analysis

- Same features as in MQXFA07
- Metallographic analysis of lead end shows broken filaments at wedge-spacer interface

## 3. End spacer-wedge transitions

By M. Crouvizier, A. Moros, S. Sgobba, CERN



Crack field is in correspondence to resin/copper wedge interface

S. Sgobba et al., "Advanced Examination of Nb<sub>3</sub>Sn Coils and Conductors for the LHC luminosity upgrade: Computed Tomography and Materialographic Analyses", **this session**

# Covid impact

- Changes to assembly procedures caused by COVID requirements
  - #1: change in bolting procedure for increasing tech distance
  - #2: the technician who had been leading the coil-pack assembly operations was removed from that task (starting from MQXFA06) because not vaccinated.
- COVID lockdown
  - → Stop in fabrication of coil 214 after Inner-Layer was cured may have weakened wedge-spacer bond
- Less supervision caused by COVID
  - → increased probability of non-uniform pole-key gaps and other differences.

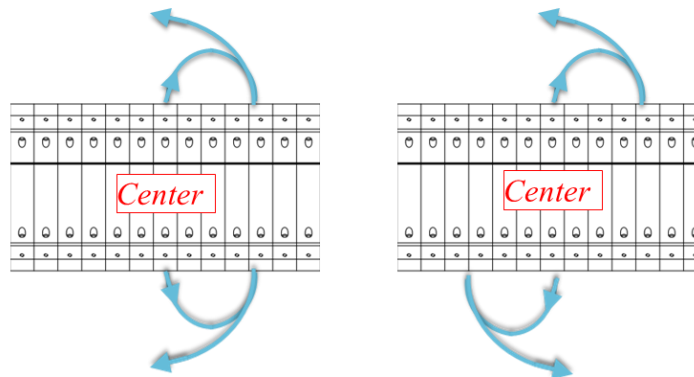
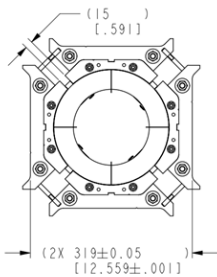

Courtesy of P. Ferracin and D. Cheng

# Preventive Actions

In order to prevent reoccurrence of this issue,

- Design change for larger pole-key gaps:
  - From 200  $\mu\text{m}$  to 400  $\mu\text{m}$  - average pole key gap per side
- Revised MQXFA Series Magnet Production Specification:
  - Added spec for minimum gap on each coil at each longitudinal location: 300  $\mu\text{m}$  per side

D. Cheng et al., "The challenges and solutions of meeting the assembly specifications for the 4.5 m long MQXFA magnets for the Hi-Luminosity LHC" **2L0r2A-02**

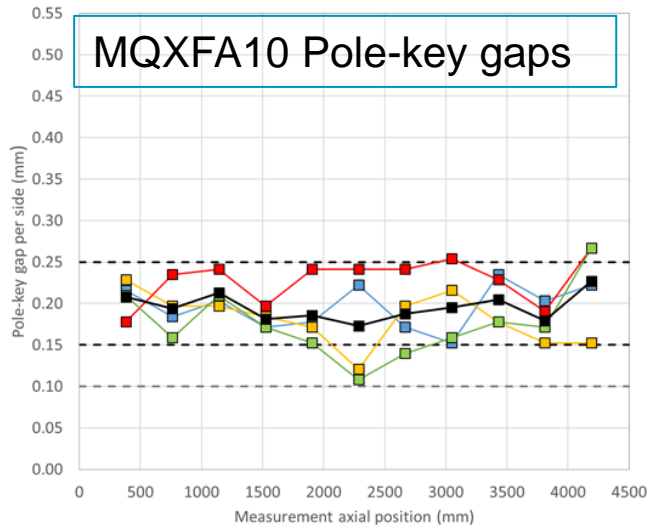

Courtesy of P. Ferracin

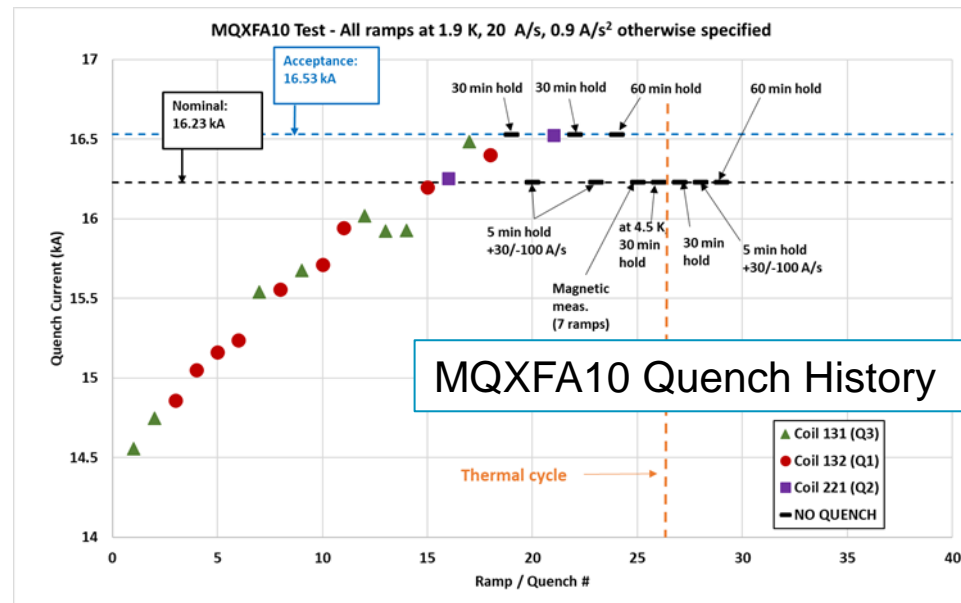

Courtesy of A. Ben Yahia



# Endurance Tests

- Previous endurance tests were successfully performed on short models
- MQXFA05 met requirements after 5 thermal cycles, 52 quenches and 79 powering cycles

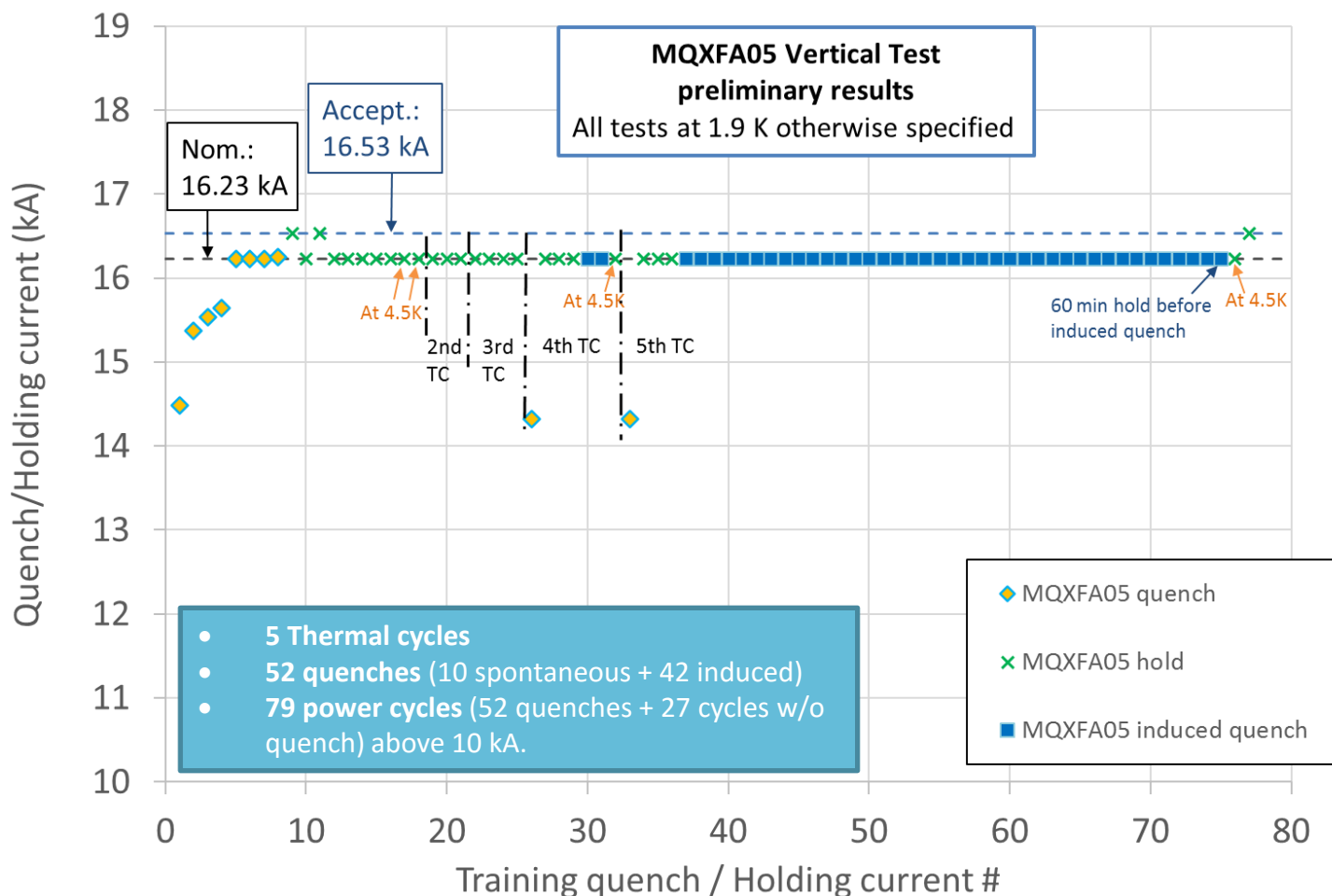

# MQXFA11 “Resilience Test”

- The truck transporting the MQXFA11 magnet from LBNL to BNL was rear ended by another truck.
- The main hit took place on the right back corner. During the incident the truck rear axle disengaged as displayed below. Nobody was injured.
- The magnet was moved to FNAL. Upon arrival a visual inspection was performed followed by electrical checkout, metrology survey, analysis of the fiber optic sensors and accelerometer data analysis
  - Max shock: 6 or 10 g vertical (depending on the device in the same accelerometer unit)
  - Duration: 5 ms
- All tests and analyses were OK. Magnet was shipped to BNL



Courtesy of T. Cruise



Courtesy of J. Blowers

# MQXFA11 “Maverick” Quench History

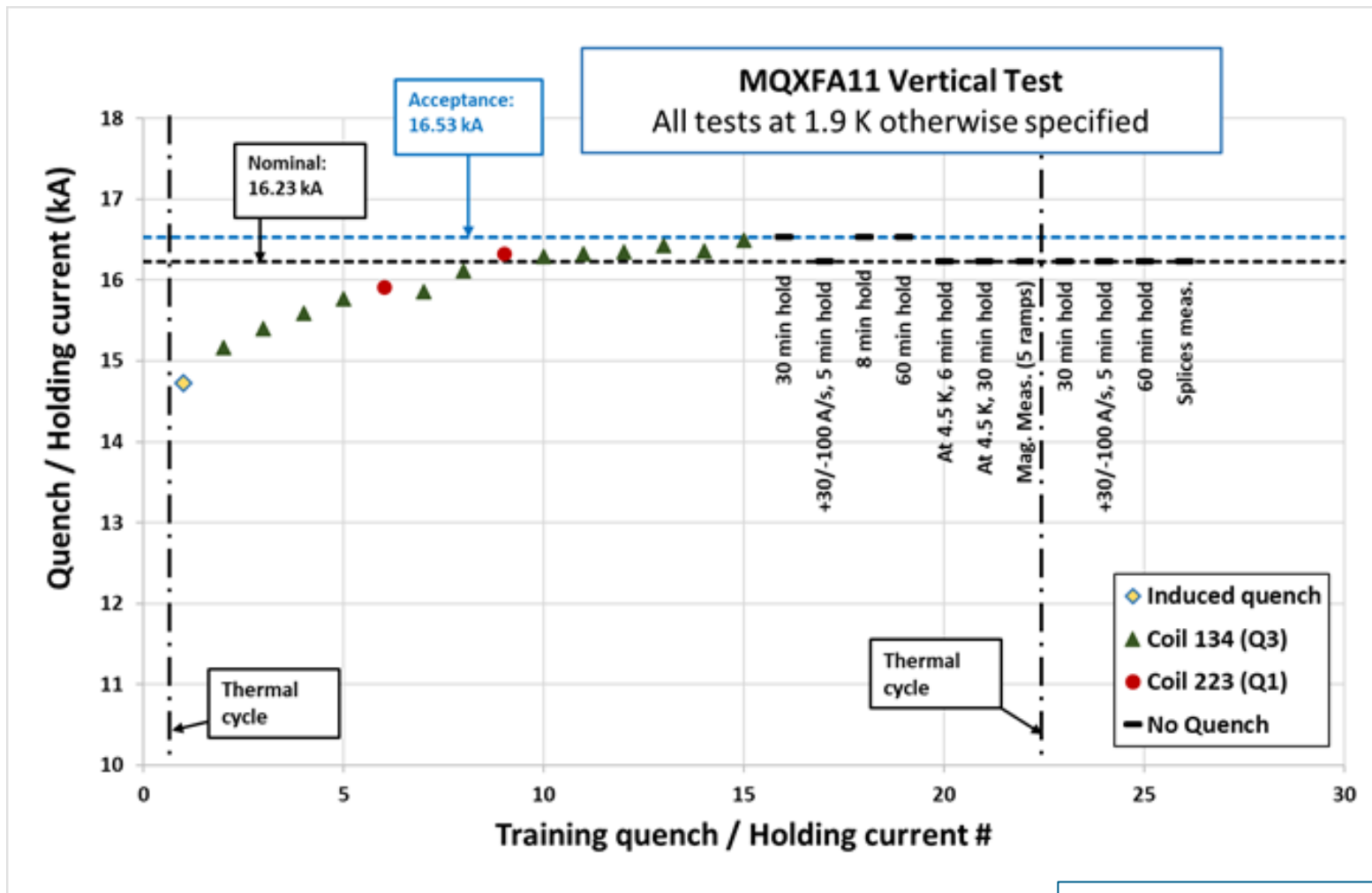

Courtesy of A. Ben Yahia

# Conclusions - I

- AUP is close to 50% MQXFA magnet fabrication
- 6 out of 8 magnets met vertical test requirements
- MQXFA07/08 “smoking gun” was found
  - Mechanism is understood
  - Covid restrictions and lockdown contributed to the degradation mechanism
  - Design change (larger gaps) and Specification revision (minimum gaps spec.) are going to prevent reoccurrence in future magnets
  - MQXFA10 & MQXFA11 demonstrated that this issue is over
- MQXFA05 demonstrated **Endurance**
- MQXFA11 demonstrated **Resilience**

# Question & Answer

- Is it possible to fabricate Nb<sub>3</sub>Sn magnets for particle accelerator?
- Yes!
  - It is challenging because Nb<sub>3</sub>Sn is strain sensitive and brittle
  - Therefore, design and specifications must assure that **all points in the acceptable-tolerance space are safe**
    - Including: parts tolerances, assembly tolerances, procedure variabilities, operation variabilities, ...
  - And cost per magnet should be reduced

G. Ambrosio et al., "Development and demonstration of next generation technology for Nb<sub>3</sub>Sn accelerator magnets with lower cost, improved performance uniformity, and higher operating point in the 12-14 T range" <http://arxiv.org/abs/2203.07352>

# Backup Slides



*Based on these findings, we understand that coil 214 pole-key gaps were closed at cold, whereas those of other coils were open. During magnet energization this difference caused tensile strain at wedge-spacer interfaces in coil 214 ends. In early ramps to quench (possibly before or during ramp #4) the bonding between the copper wedge and the resin (filled with S-glass) gave away in the lead end increasing the strain on the strands closest to that interface. The “increased” strain degraded some strands and triggered the enhanced self-field instability behavior. This mechanism caused quench #4 and all subsequent quenches at 1.9 K and 20 A/s.*

*These quenches with hot-spot close to the wedge-spacer interface may have exacerbated this mechanism increasing the local strain and strand damage, and therefore causing the current drop (~1 kA) from quench #4 to #8.*

# MQXFA08 Quench History

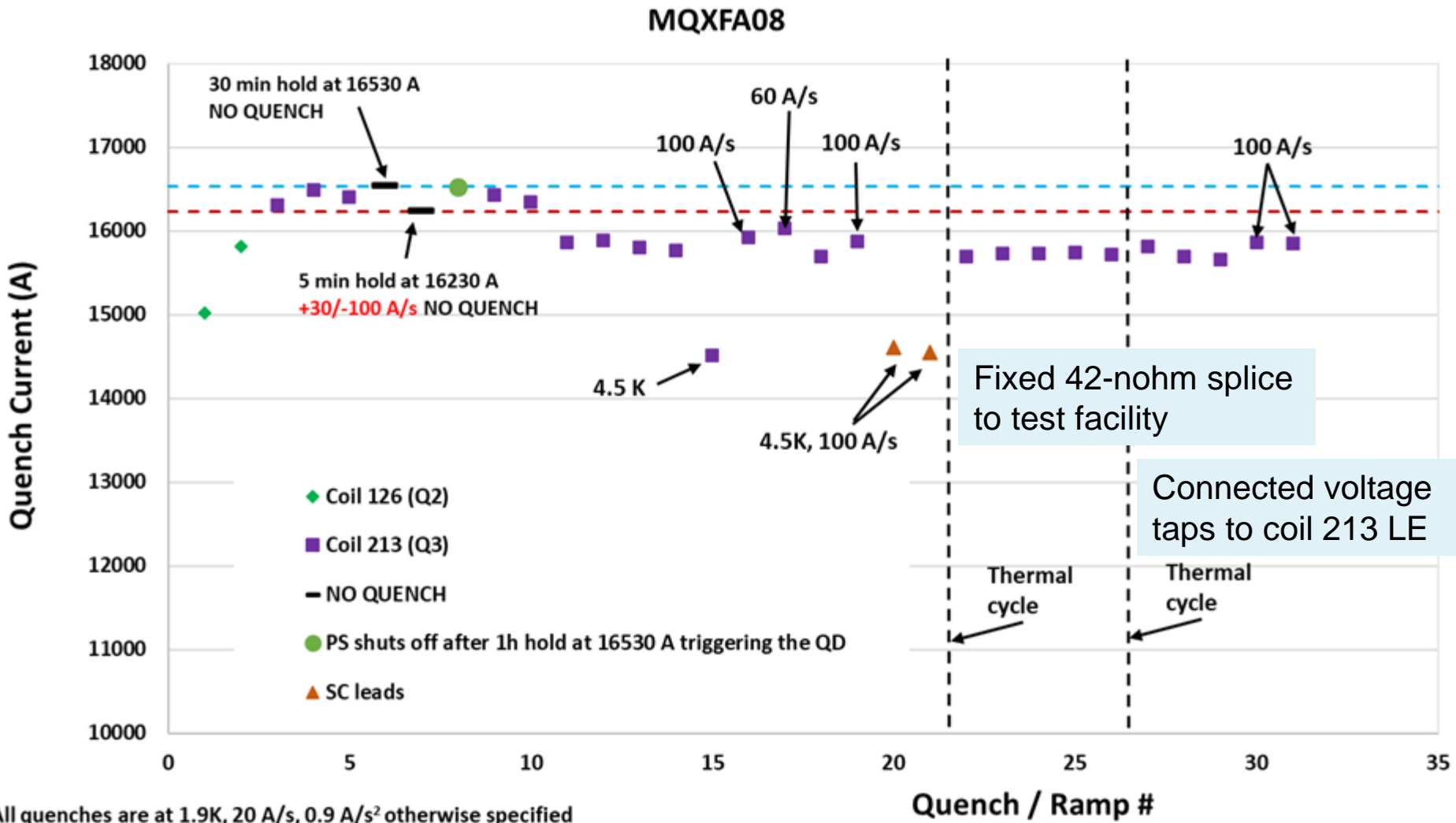

All quenches are at 1.9K, 20 A/s, 0.9 A/s<sup>2</sup> otherwise specified



# Magnet Dis-assembly

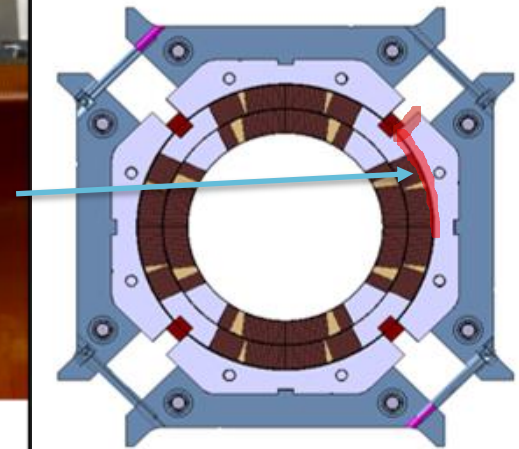
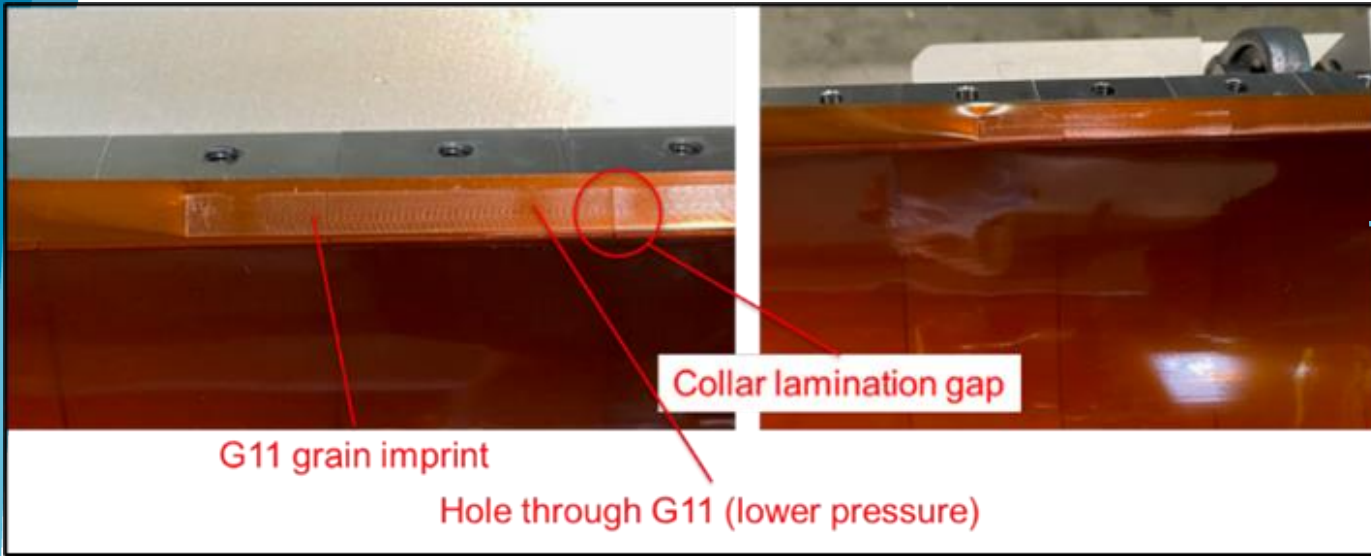

- Pressure imprint in Q3 pole-key gaps
- Unusual marks at wedge-spacer interface in lead end

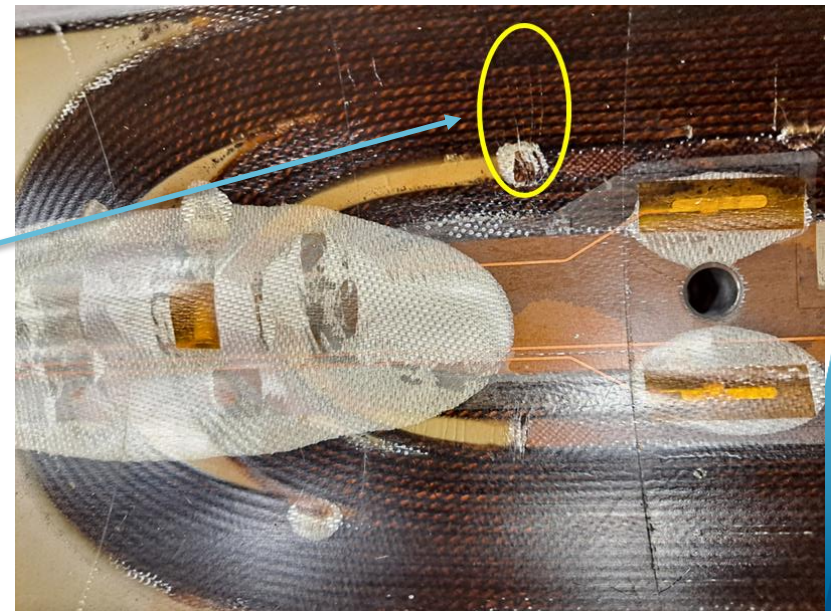

# Covid impact on Magnet Assembly

- Changes to magnet assembly procedures due to Covid requirements:
- #1: change in bolting procedure for increasing tech distance
- #2: the technician who had been leading the coil-pack assembly operations up to magnet MQXFA05 was removed from that task (starting from MQXFA06) because not vaccinated.

Before change #1

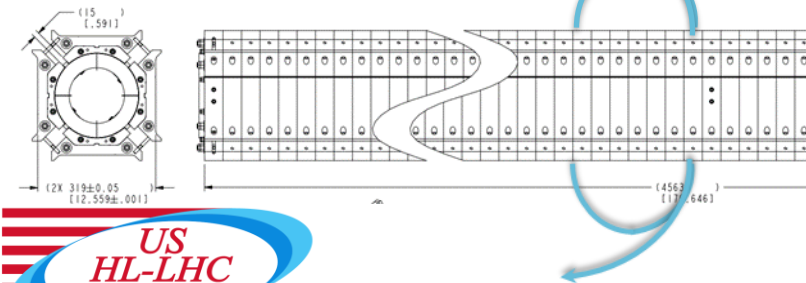

After change #1

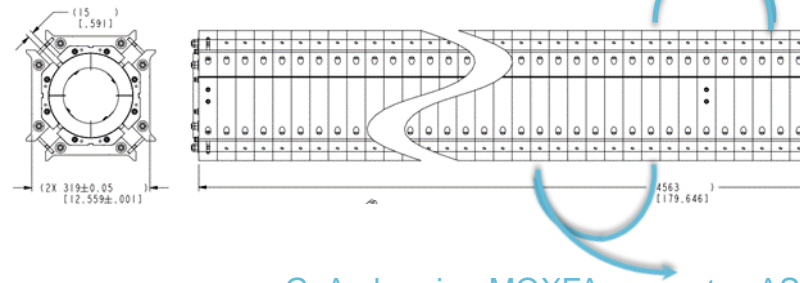

# Assessment of MQXFA Data & Travelers

Completed assessment of travelers for Coil Fabrication at BNL, and Magnet Assembly at LBNL:

- Assessment of coil parameters, which are being tracked, did not show any anomaly
- Coil traveler assessment did not show any issue in addition to known DRs
- Assessment of magnet assembly & preload data in next slides

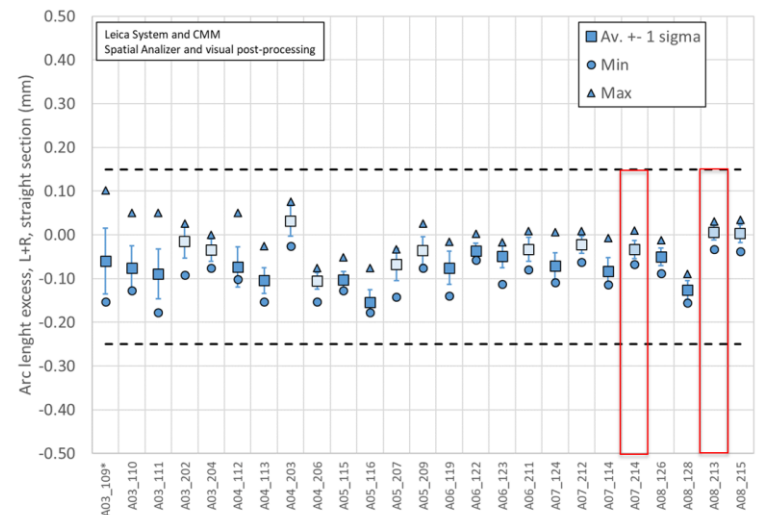
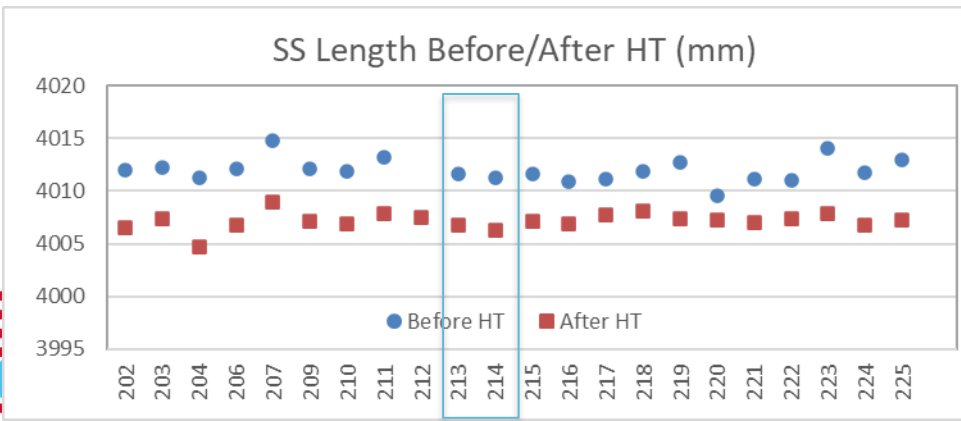

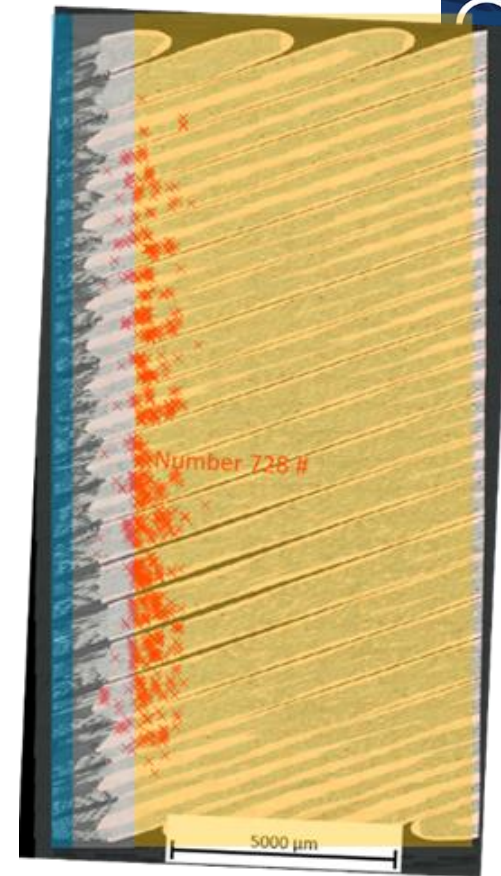
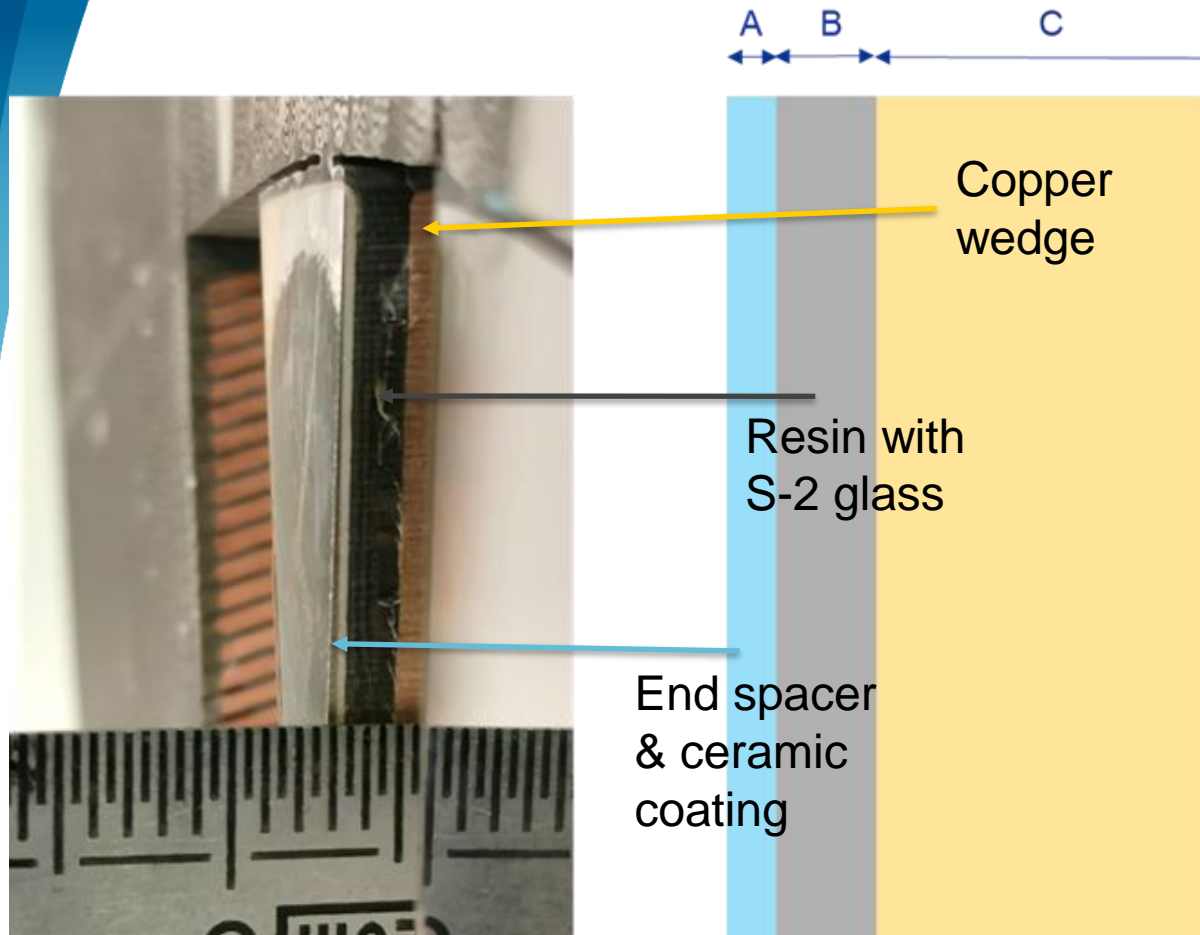

Left: coil section after samples were extracted for metallographic inspection.  
 Center: color scheme used to show the position of filament cracks with respect to the W-S transition in the following figure. A: End spacer + ceramic coating  $\approx 0,5$  mm; B: resin (filled with S-2 glass) between end spacer and wedge  $\approx 1,5$  mm; C: copper wedge.  
 Right: color scheme applied on sample with broken filaments.

By M. Crouvizier, A. Moros, S. Sgobba, CERN