



*Joint Experimental-Theoretical Physics Seminar  
Fermilab*

*13 May 2022*

Jonathan Feng, UC Irvine



# HISTORY

- This talk will be very forward looking. But to look forward, let's first look back.
- Last year was the 50<sup>th</sup> anniversary of the birth of hadron colliders.
- In 1971, CERN's Intersecting Storage Rings (ISR), with a circumference of  $\sim 1$  km, began colliding protons with protons at the center-of-mass energy of 30 GeV (later raised to 62 GeV).

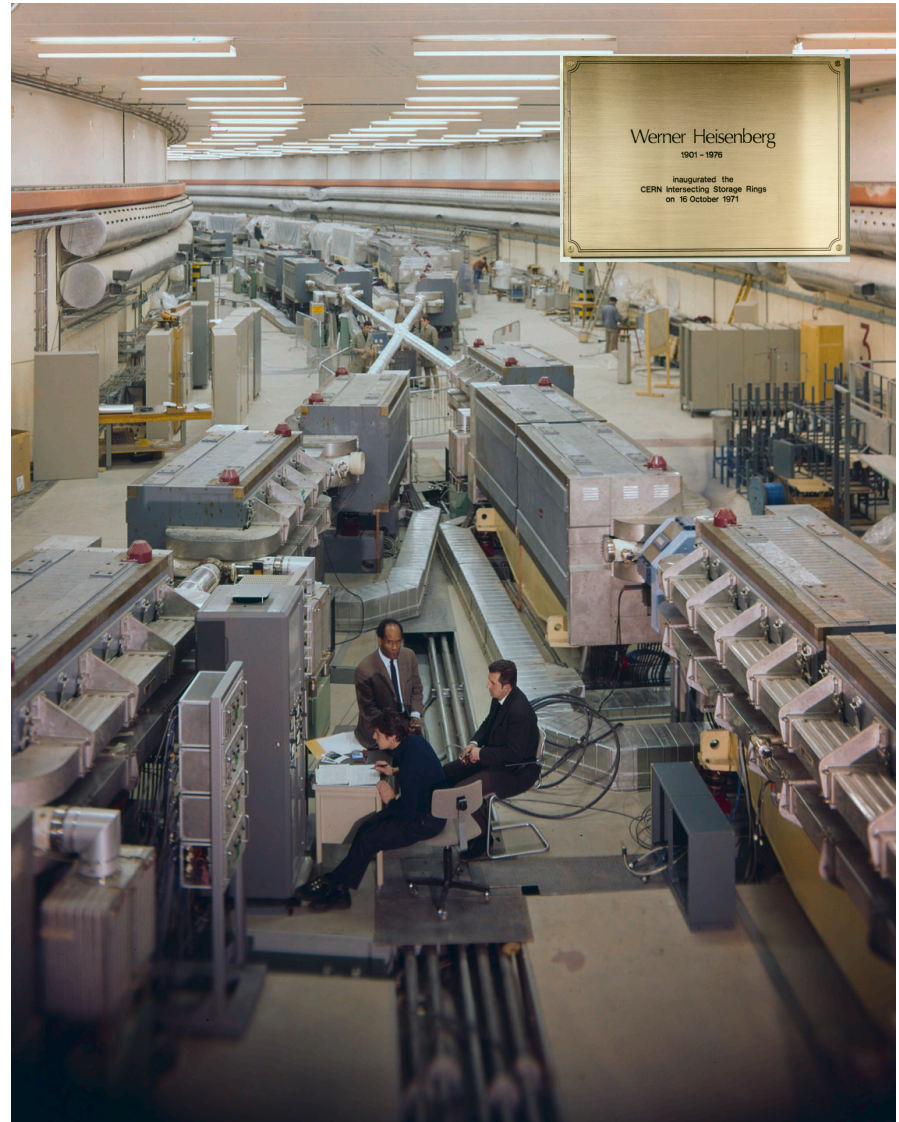

# ISR'S LEGACY

- 50<sup>th</sup> anniversaries are fascinating. There have been many articles and talks by eminent physicists looking back on the ISR's legacy.
  - “Enormous impact on accelerator physics, but sadly little effect on particle physics.” – Steve Myers, talk at “The 50th Anniversary of Hadron Colliders at CERN,” October 2021.
  - “There was initially a broad belief that physics action would be in the forward directions at a hadron collider.... It is easy to say after the fact, still with regrets, that with an earlier availability of more complete... experiments at the ISR, CERN would not have been left as a spectator during the famous November revolution of 1974 with the  $J/\psi$  discoveries at Brookhaven and SLAC .” – Lyn Evans and Peter Jenni, “Discovery Machines,” CERN Courier (2021).
- **An obvious question: Are we making a similar mistake right now at the LHC?**



# MISSED OPORTUNITIES AT THE LHC

- Pop quiz: What process produces the highest energy neutrinos at the LHC?  
Answer: It's not  $W$  decays, but pion (and other meson) decays.
- In contrast to the ISR days, there is now broad belief that the most interesting physics is at high  $p_T$ .
- But by far the largest fluxes of high-energy light particles (e.g., neutrinos and anti-neutrinos of all flavors, pions, kaons, D mesons, ...) are in the far-forward direction.

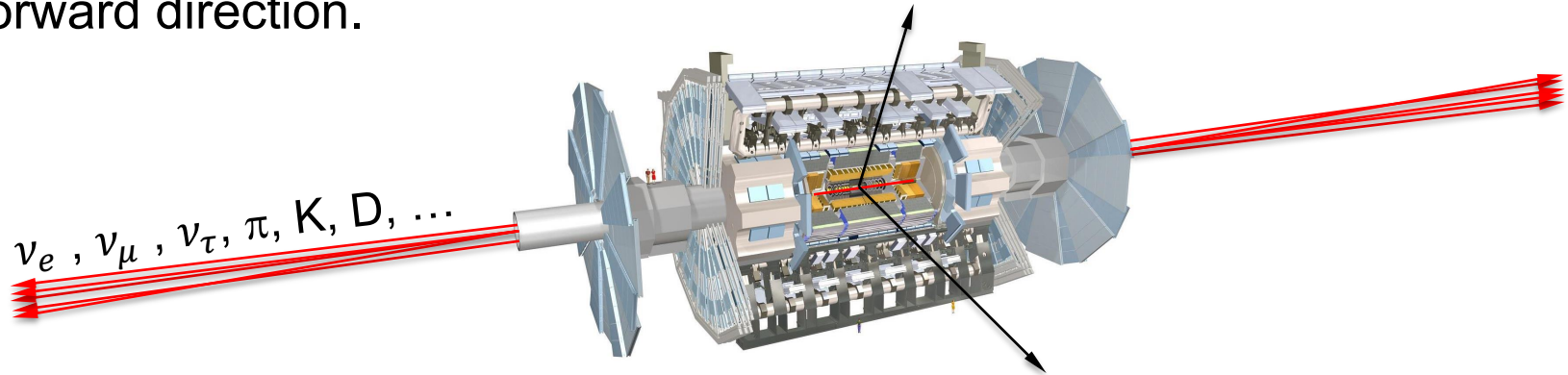

- We are now currently missing a wide variety of SM opportunities to learn about neutrinos, QCD, and astroparticle physics.
- We may also be missing BSM opportunities to discover new particles.



# NEW PARTICLES

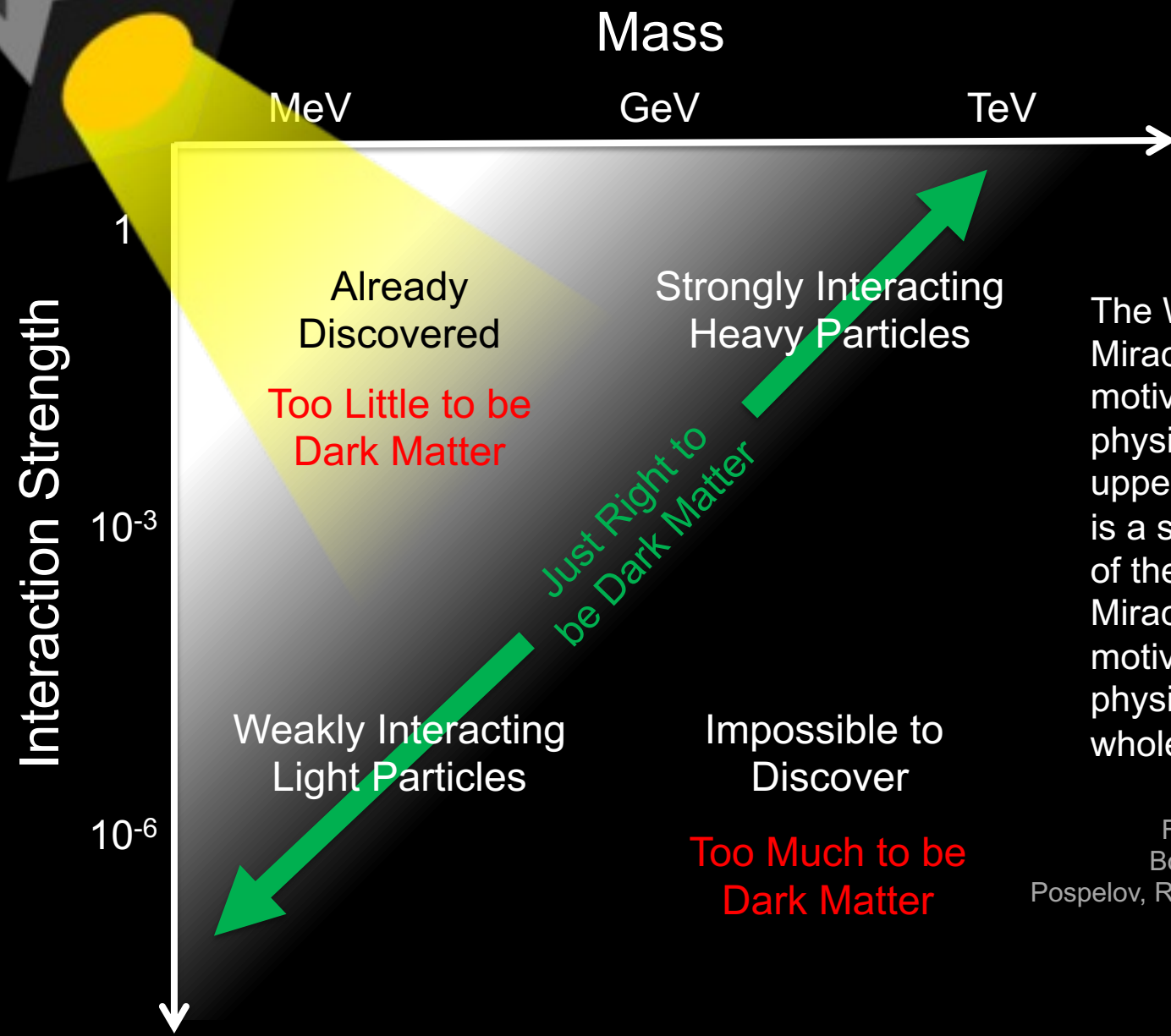

The WIMP Miracle, which motivates new physics in the upper right corner, is a special case of the WIMPless Miracle, which motivates new physics along the whole diagonal.

Feng, Kumar (2008)  
Boehm, Fayet (2003)  
Pospelov, Ritz, Voloshin (2007)

# SPECIFIC EXAMPLES

- Suppose there is a dark sector that contains dark matter  $X$  and also a dark force: dark electromagnetism.
- The force carriers of our sector and the dark sector will mix
  - perhaps suppressed, but completely generic, since a renormalizable operator

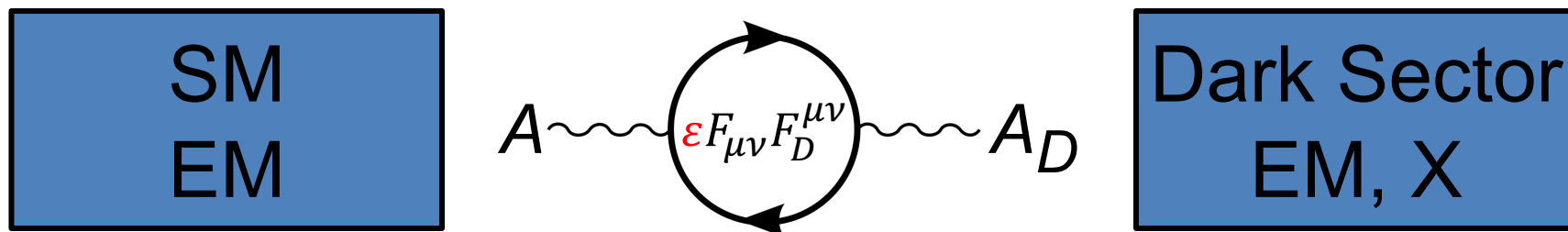

- The result? A new particle, the **dark photon  $A'$** : like a normal photon, but with an unknown mass  $m_{A'}$  and couplings suppressed by  $\epsilon$ . It travels through matter without interacting, but eventually decays through  $A' \rightarrow e^+ e^-$ , ...

Holdom (1986)

- Many other similar possibilities (portals, LLPs, FIPs, ...):  $B - L$ ,  $L_\mu - L_\tau$  and other light gauge bosons, dark Higgs bosons  $X \rightarrow K^+ K^-$ , axion-like particles  $a \rightarrow \gamma\gamma$ , sterile neutrinos  $N \rightarrow l^+ l^- \nu$ , millicharged particles, ...

# SEARCHES FOR NEW LIGHT PARTICLES

- The existing large LHC detectors are beautifully designed to find **strongly-interacting heavy particles**.
- But they are also perfectly designed to **not** find **weakly-interacting light particles**. These are dominantly produced in the rare decays of light particles:  $\pi$ ,  $\eta$ ,  $K$ ,  $D$  and  $B$  mesons along the forward direction, and so the new particles escape through the **blind spots** down the beamline.

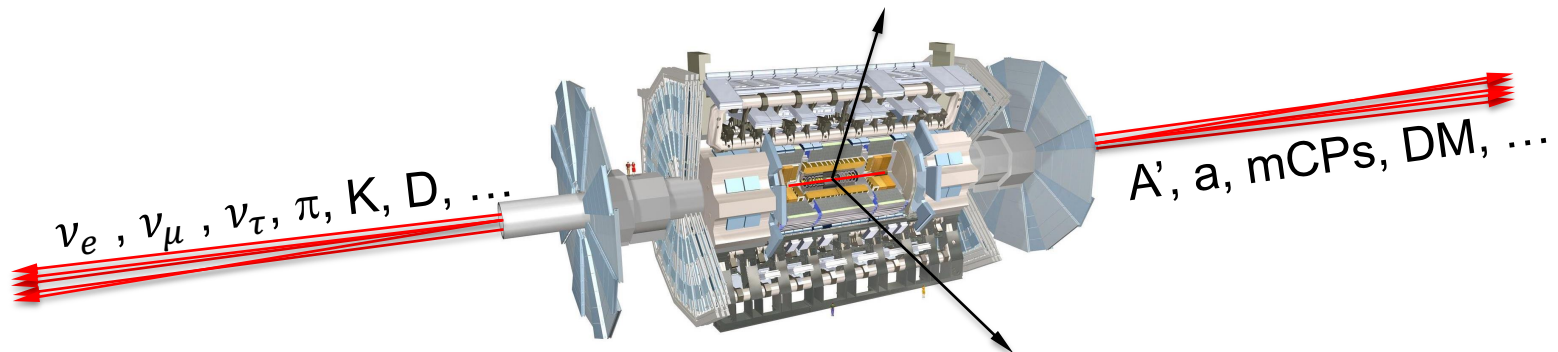

- There are both SM and BSM motivations to explore the “wasted”  $\sigma_{\text{inel}} \sim 100 \text{ mb}$  and cover these blind spots in the **far forward region**.
- We cannot block the beams, but if we go far away, the proton beams are bent by magnets, whereas light, weakly-interacting particles go straight.

# THE BASIC IDEA

Feng, Galon, Kling, Trojanowski (2017)

Kling, Trojanowski (2018)

Feng, Galon, Kling, Trojanowski (2018)

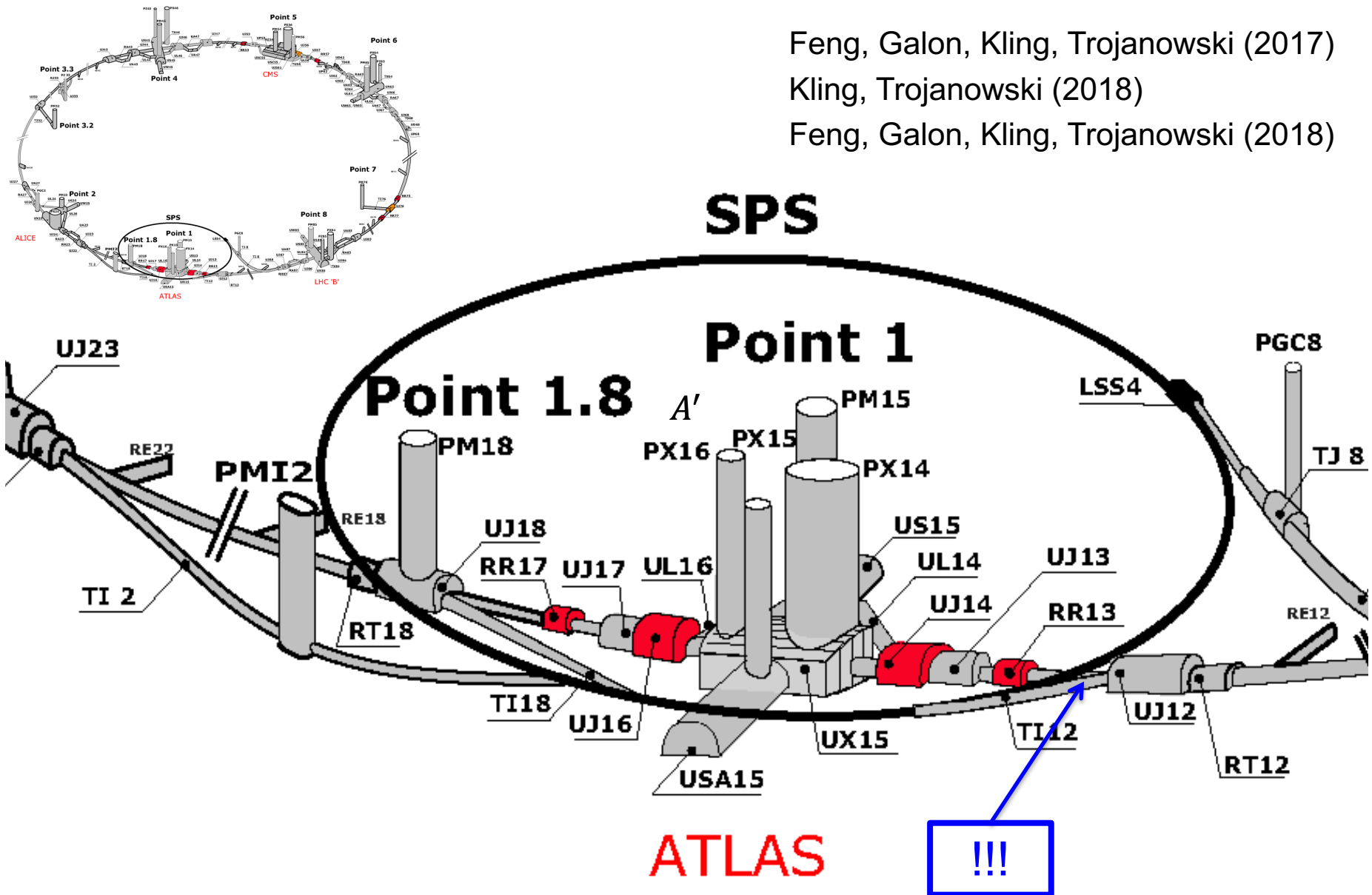



# THE FAR-FORWARD REGION

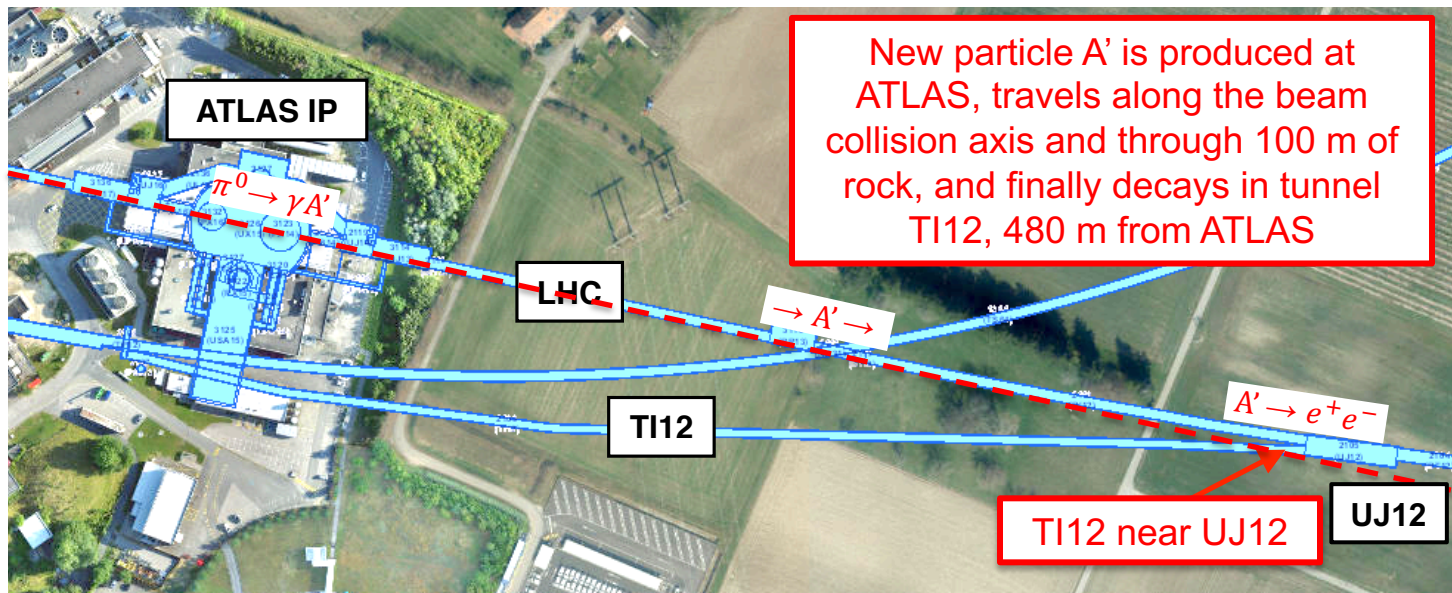

# PARTICLE PATH FROM ATLAS TO T112

Dougherty, CERN Integration (2019)

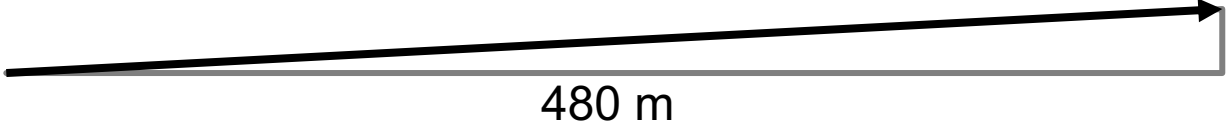

# HOW BIG DOES THE DETECTOR HAVE TO BE?

- Momentum:  250 MeV
- Space:  12 cm

- From pion decays, the opening angle is 0.2 mrad ( $\eta \sim 9$ ); cf. the moon (7 mrad).
- TeV dark photons (or any other new particles produced in  $\pi$ ,  $\eta$ ,  $K$ ,  $D$ ,  $B$  decay) are far more collimated than shown below, motivating a new, small, fast, cheap experiment at the LHC.

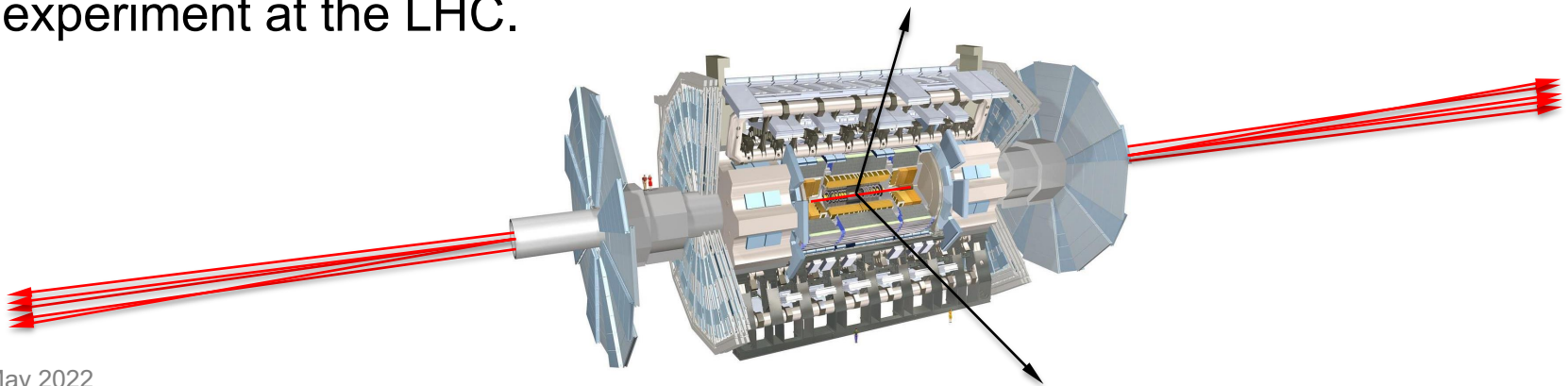





# FASER TIMELINE

---

- September 2017: Initial proposal
- July 2018: LOI submitted to the CERN LHCC
- October 2018: Approval from [ATLAS SCT](#) and [LHCb Collaborations](#) for use of spare detector modules
- November 2018: Technical Proposal submitted to the LHCC
- November 2018 – January 2019: Experiment funded by the [Heising-Simons](#) and [Simons Foundations](#)
- March 2019: FASER approved as 8<sup>th</sup> LHC detector by [CERN](#)
- December 2019: FASER<sub>v</sub> approved as 9<sup>th</sup> LHC detector by [CERN](#)
- March 2021: FASER fully installed, commissioning of the detector begins
- May 2021: FASER<sub>v</sub> finds first candidate collider neutrinos
- April 2022: FASER and FASER<sub>v</sub> begin collecting data in Run 3

# FIRST FASER COLLABORATION MEETING

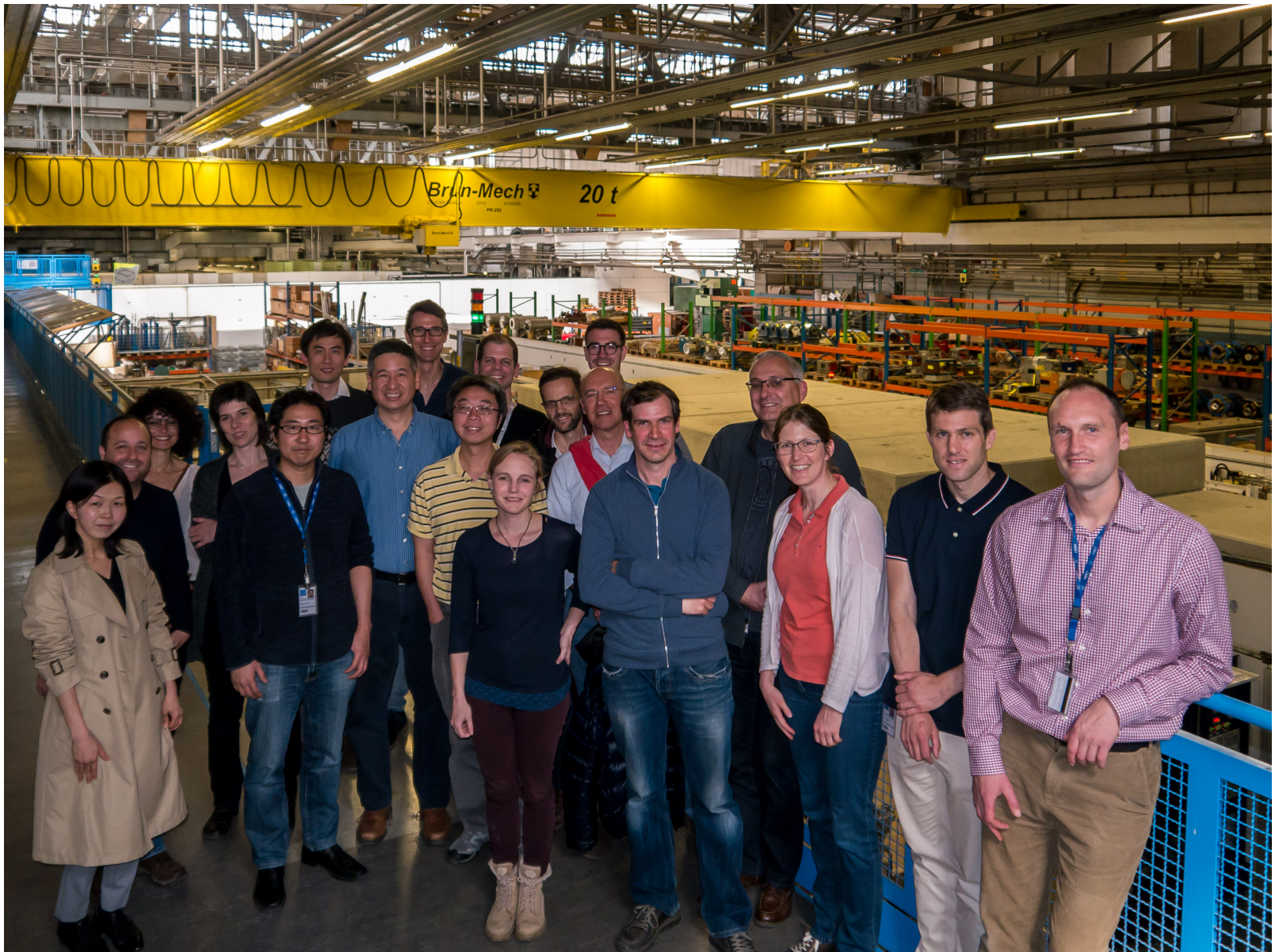

# FASER COLLABORATION TODAY

75 collaborators, 22 institutions, 9 countries





# THE FASER DETECTOR

- Nothing incoming and 2 ~TeV, opposite-sign charged tracks pointing back to the ATLAS IP: a “light shining through (100 m-thick) wall” experiment.
- Scintillators veto incoming charged tracks (muons), magnets split the charged tracks, which are detected by tracking stations and a calorimeter.

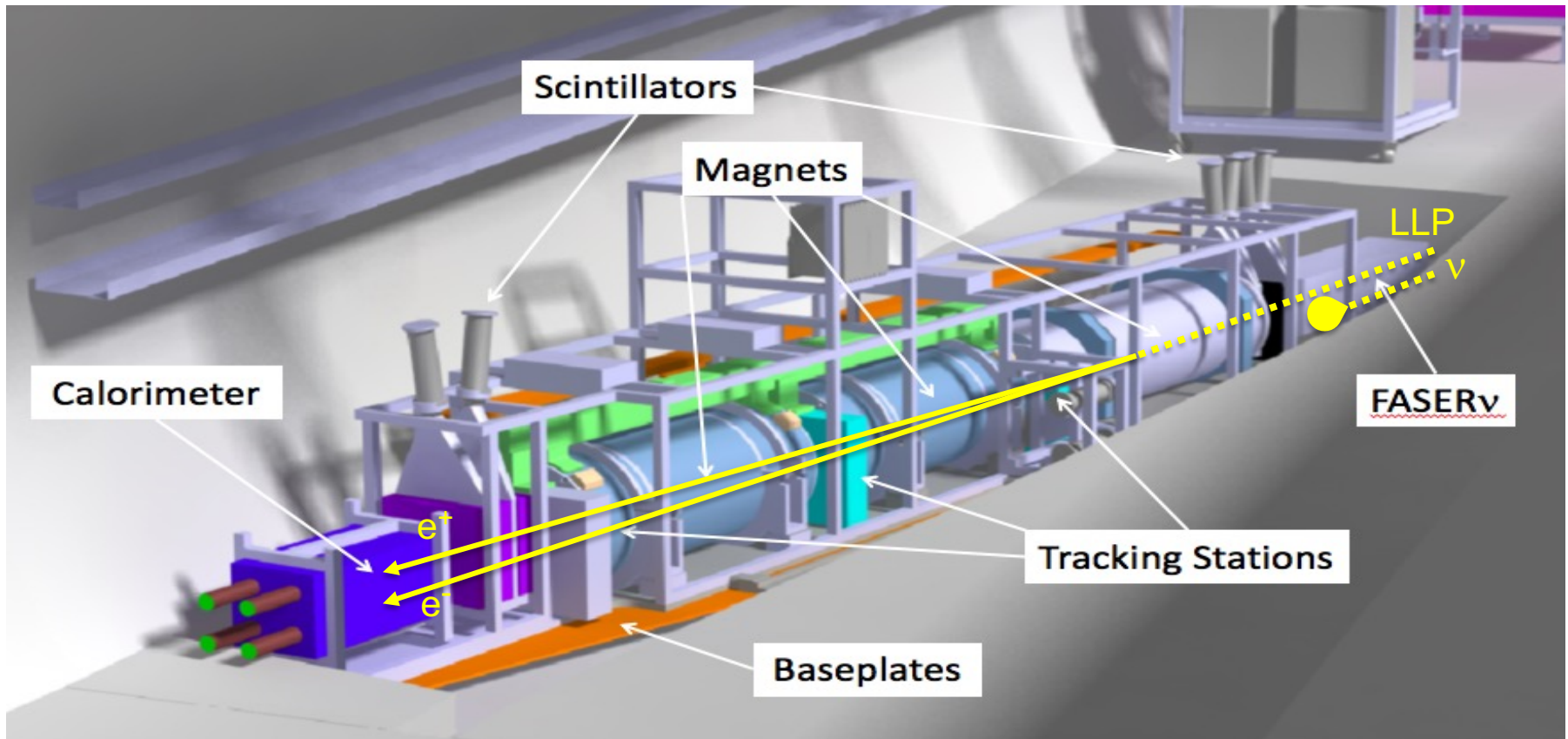



# FASER IN TUNNEL T112

- The beam collision axis was located to mm accuracy by the CERN survey department. To place FASER on this axis, a trench was required to lower the floor by 46 cm.
- The trench was completed by an Italian firm just hours before COVID shut down CERN in Spring 2020.



# MAGNETS

- FASER includes 3 magnets: 1.5 m, 1 m, and 1m long.
- 0.57 T permanent dipoles with an inner diameter of 20 cm, require little maintenance.
- Constructed by the CERN magnet group.

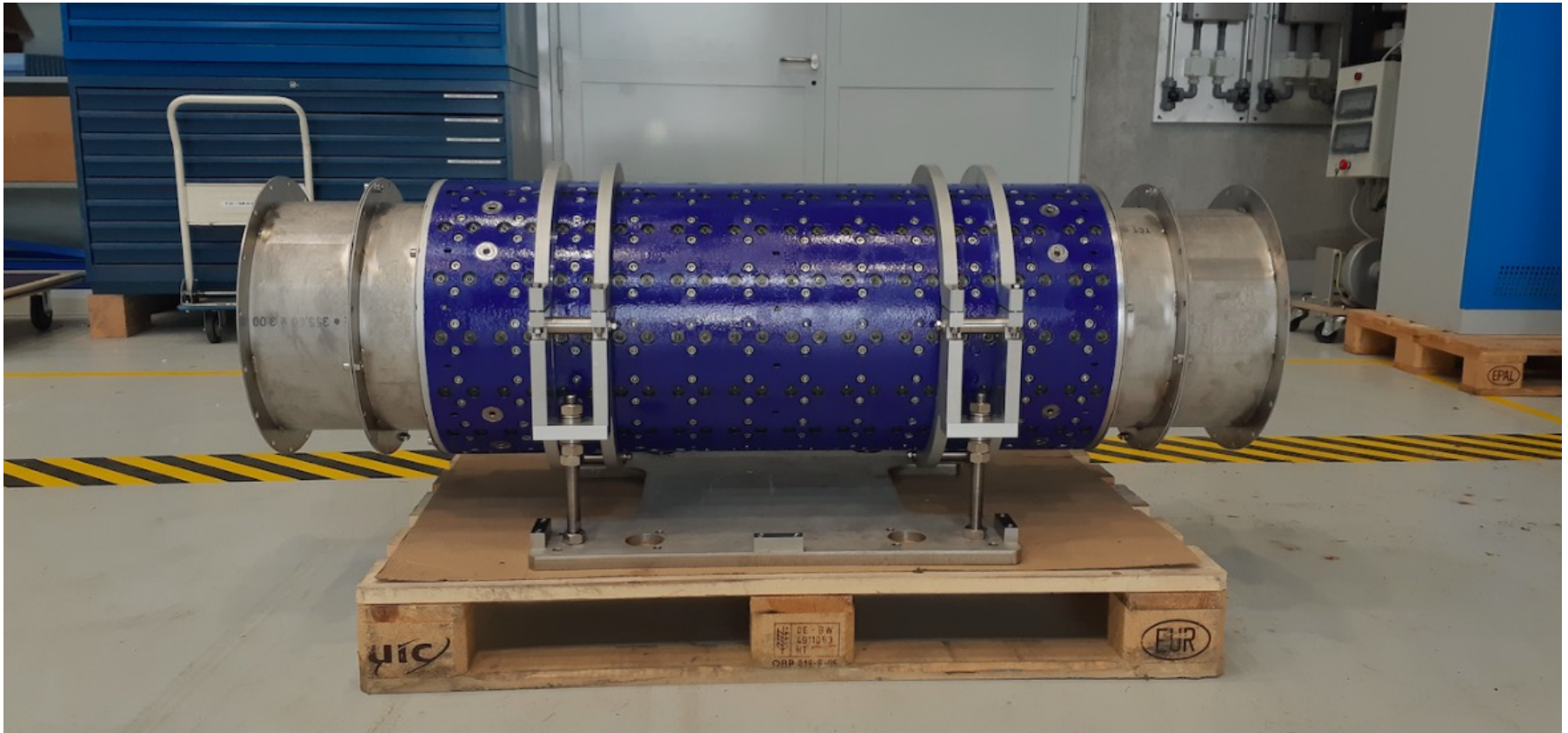

# TRACKERS

- ATLAS tracker consists of ~3000 SCT modules.
- ~300 spares were never used. ~100 of these were generously donated to FASER: 8 modules x 3 tracking planes x 4 tracking stations at FASER.

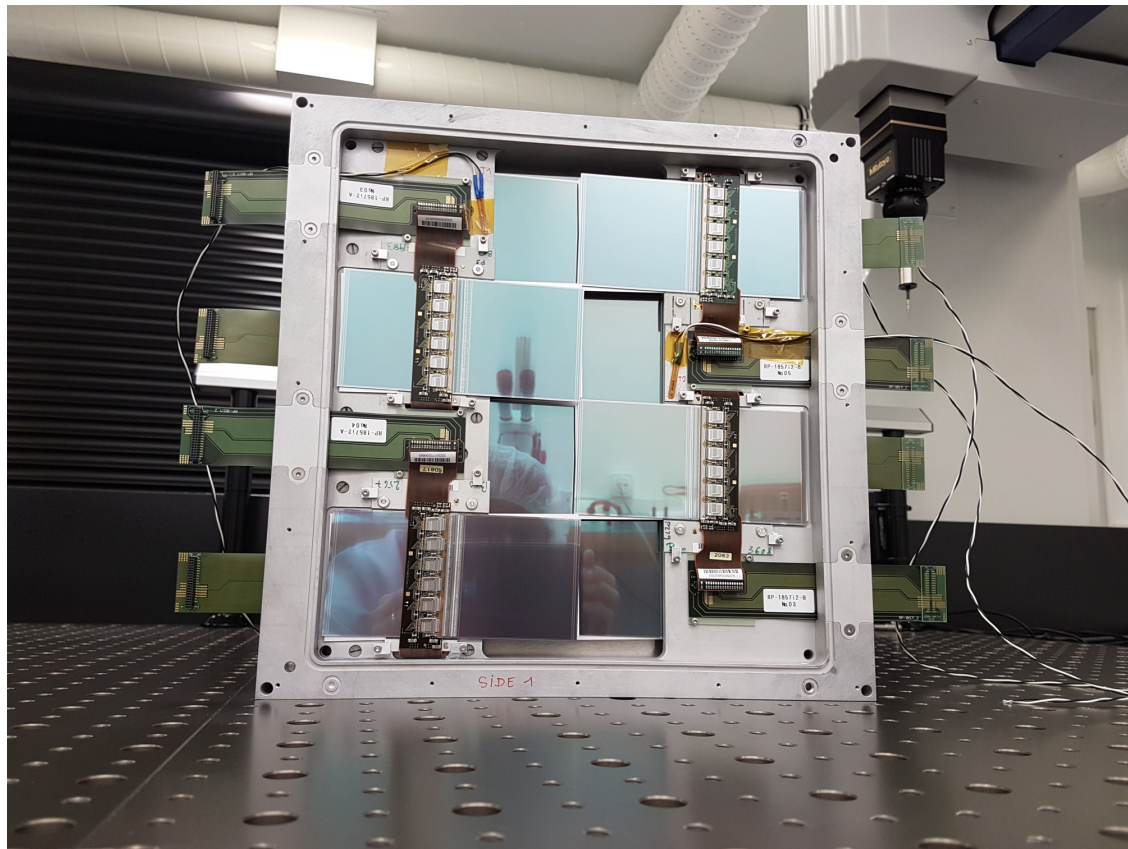



# SCINTILLATORS

---

- 4 veto scintillators, each 2cm x 30cm x 30cm, upstream of the detector. Efficiency of each one is  $> 99.99\%$ , makes muon background negligible.
- Additional beam backgrounds, simulated with FLUKA and validated with pilot detectors in 2018, are also expected to be negligible.





# FASER CURRENT STATUS

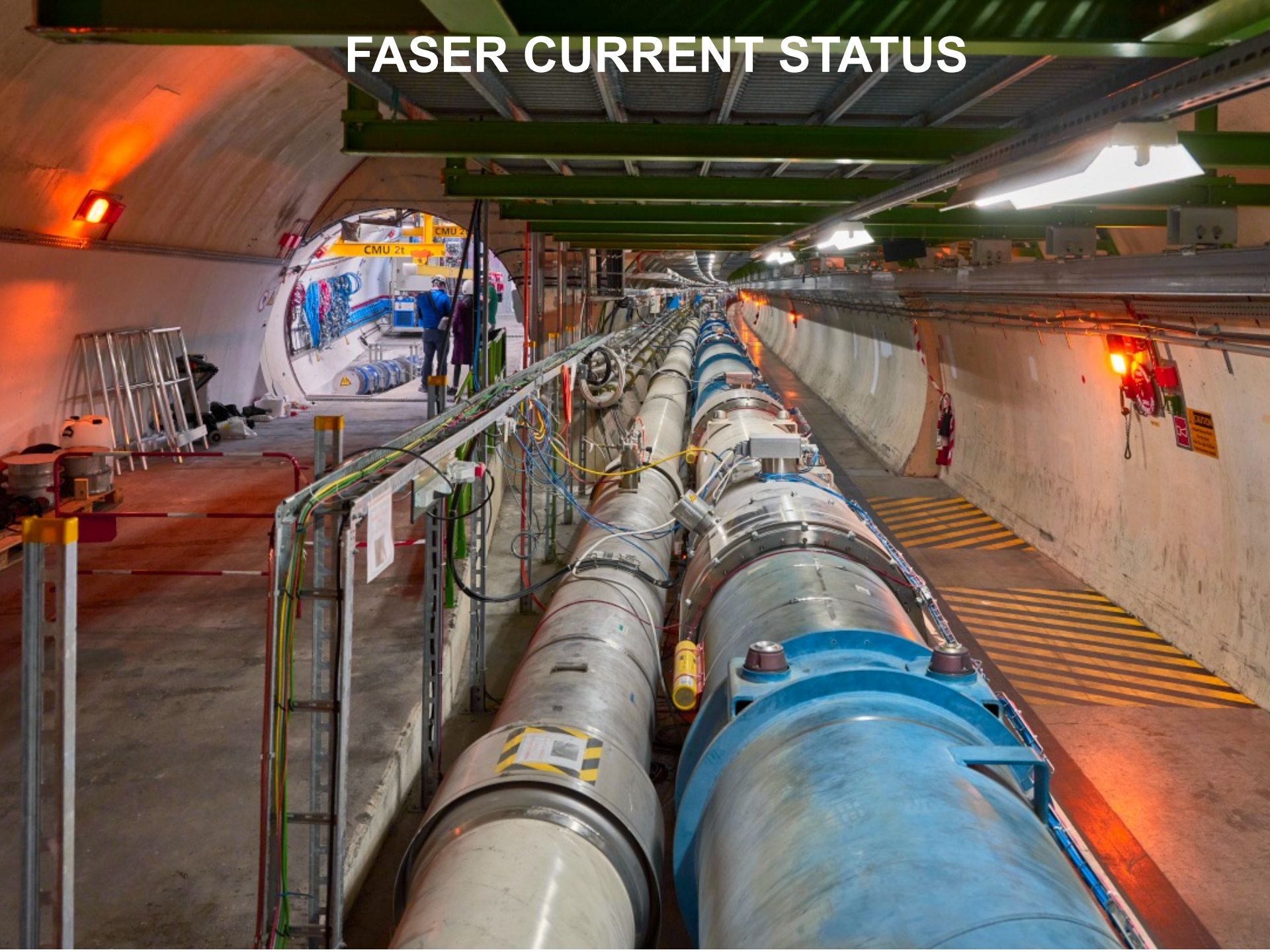



# FASER CURRENT STATUS

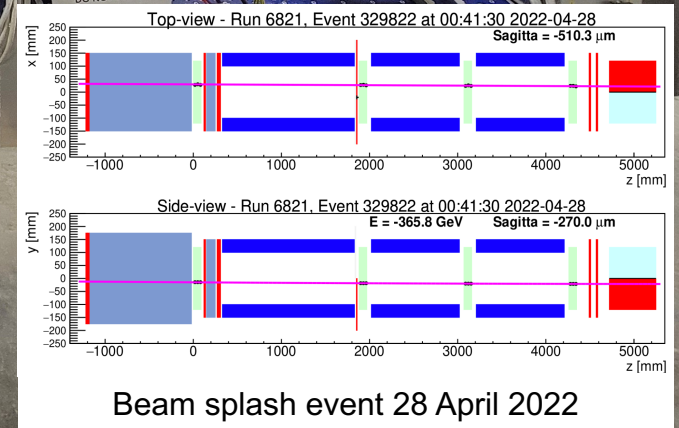
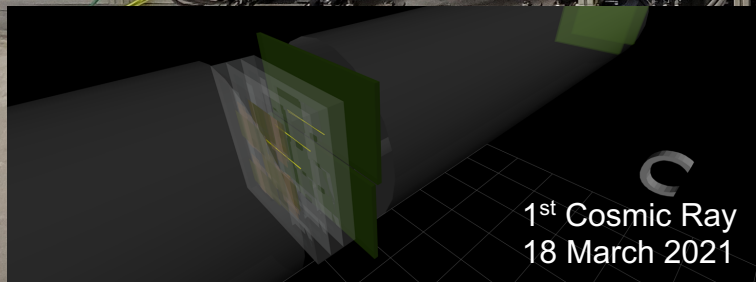
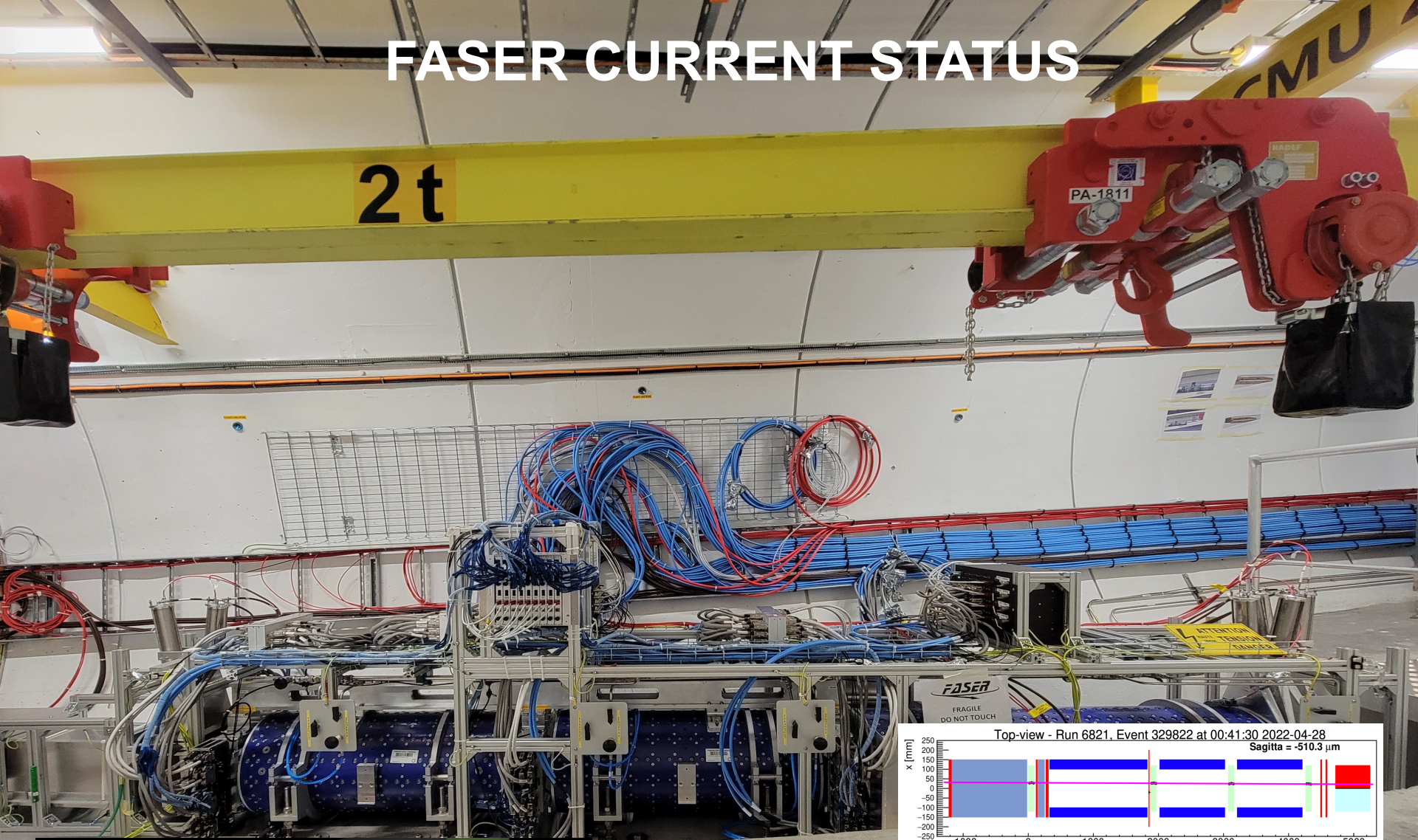

# DARK PHOTON SENSITIVITY REACH

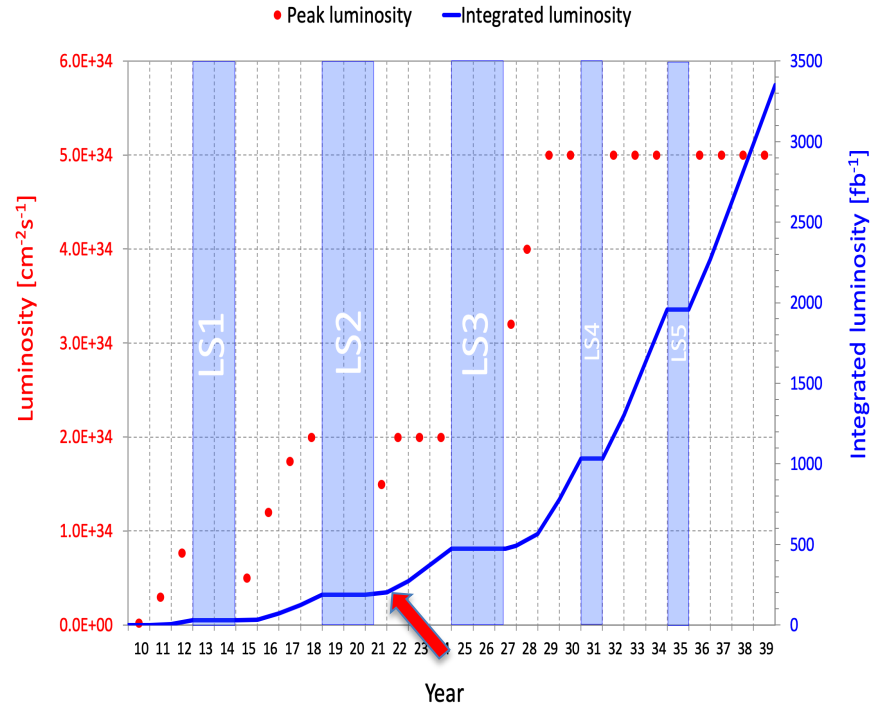
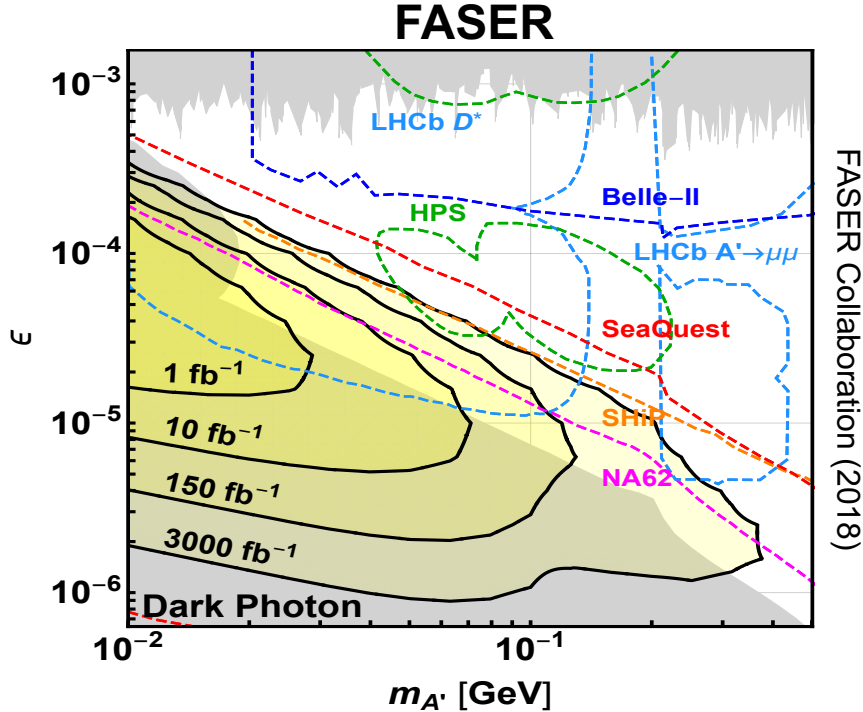

- In the coming years, many current and proposed experiments will probe the MeV-GeV region favored by WIMPlless miracle considerations, muon  $g-2$  explanations, self-interacting DM, ATOMKI anomalies, ...
- FASER probes new parameter space with just  $1 \text{ fb}^{-1}$  starting in July 2022.
- Even without a detector upgrade, the HL-LHC extends (Luminosity\*Vol) by factor of 3000 – could detect as many as 10,000 dark photons.





# COLLIDER NEUTRINOS

- In addition to the possibility of hypothetical new light, weakly-interacting particles, there are also known light, weakly-interacting particles: **neutrinos**.
- The high-energy ones, which interact most strongly, are overwhelmingly produced in the far forward direction. **Before May 2021, no candidate collider neutrino had ever been detected.**

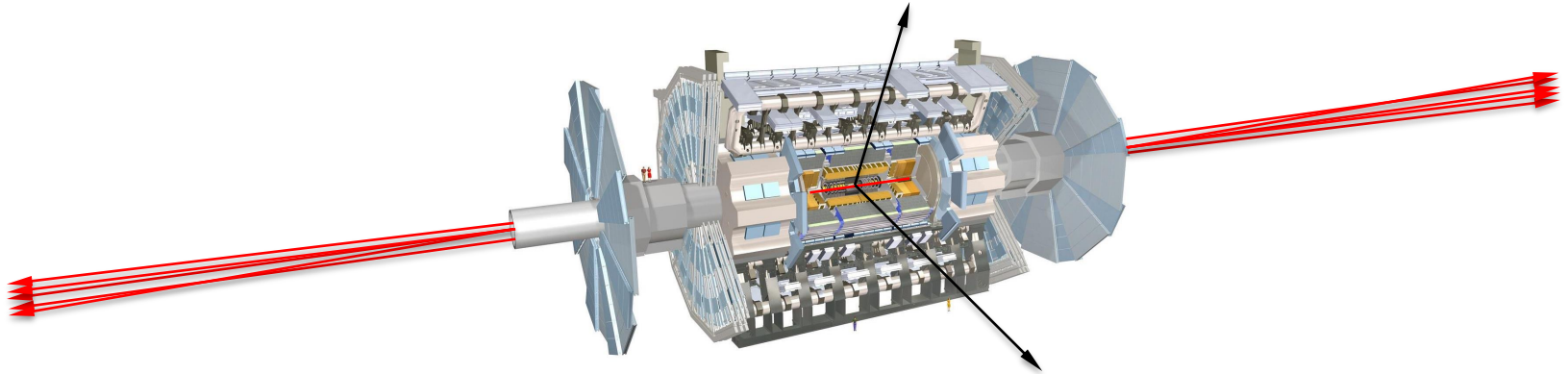

- If they can be detected, there is a fascinating new world of LHC neutrinos that can be explored.
  - The neutrino energies are  $\sim$ TeV, highest human-made energies ever.
  - All flavors are produced ( $\pi \rightarrow \nu_\mu$ ,  $K \rightarrow \nu_e$ ,  $D \rightarrow \nu_\tau$ ) and both neutrinos and anti-neutrinos.

De Rujula, Ruckl (1984); Winter (1990); Vannucci (1993)



# FIRST COLLIDER NEUTRINOS

- In 2018 a FASER pilot emulsion detector with 11 kg fiducial mass collected  $12.2 \text{ fb}^{-1}$  on the beam collision axis (installed and removed during Technical Stops).
- In May 2021, the FASER Collaboration announced the direct detection of 6 candidate neutrinos above 12 expected neutral hadron background events ( $2.7\sigma$ ).

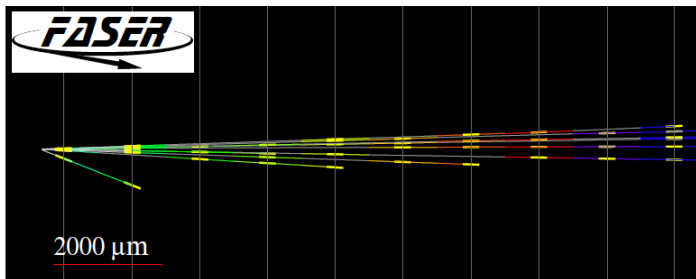
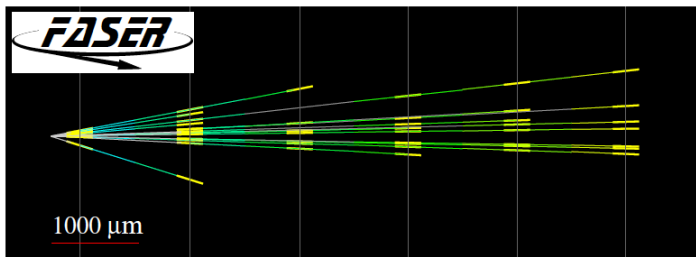

# LOCATION, LOCATION, LOCATION

## FASER Pilot Detector

Suitcase-size, 4 weeks  
\$0 (recycled parts)

6 candidate neutrinos

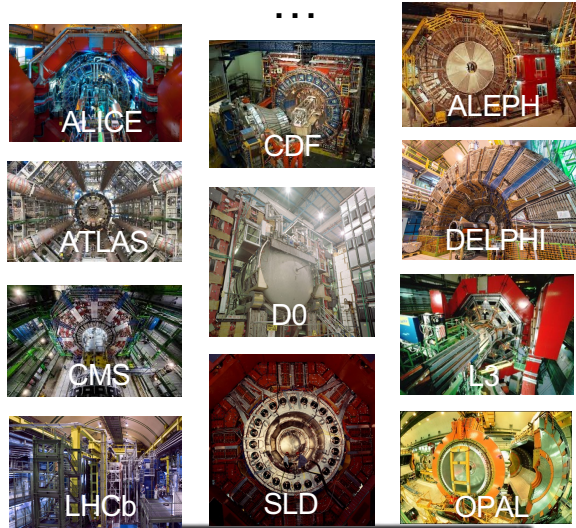

All previous  
collider detectors

Building-size, decades  
~\$10<sup>9</sup>

0 candidate neutrinos

This opens up a new field:  
neutrino physics at colliders

# THE FASER <sub>$\nu$</sub> DETECTOR

- FASER <sub>$\nu$</sub>  will detect neutrinos of all flavors; also SND@LHC, a complementary, slightly off-axis experiment on the other side of ATLAS.
  - 25cm x 30cm x 1.1m detector consisting of 770 emulsion layers interleaved with 1 mm-thick tungsten plates; target mass = 1.1 tonnes.
  - Emulsion swapped out every  $\sim 10\text{-}30 \text{ fb}^{-1}$ , total 10 sets of emulsion for Run 3.

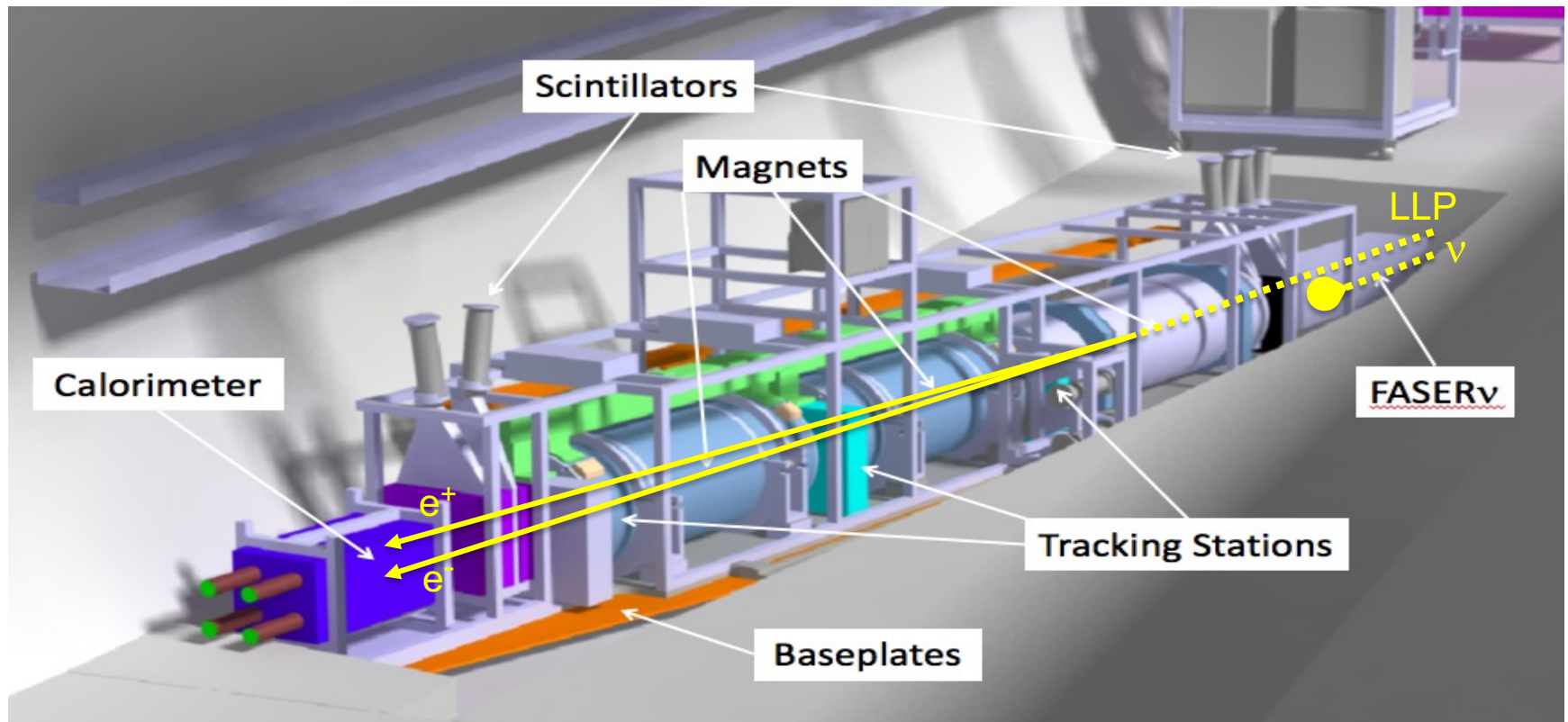

# NEUTRINO PHYSICS

- In Run 3 (2022-25), the goals of FASER $\nu$  are to
  - Detect the first collider neutrino.
  - Record  $\sim 1000$   $\nu_e$ ,  $\sim 10,000$   $\nu_\mu$ , and  $\sim 10$   $\nu_\tau$  interactions at TeV energies, the first direct exploration of this energy range for all 3 flavors.
  - Distinguish muon neutrinos from anti-neutrinos by combining FASER and FASER $\nu$  data, and so measure their cross sections independently.
  - Add significantly to the number of  $\nu_\tau$  and identify the first anti- $\nu_\tau$ .

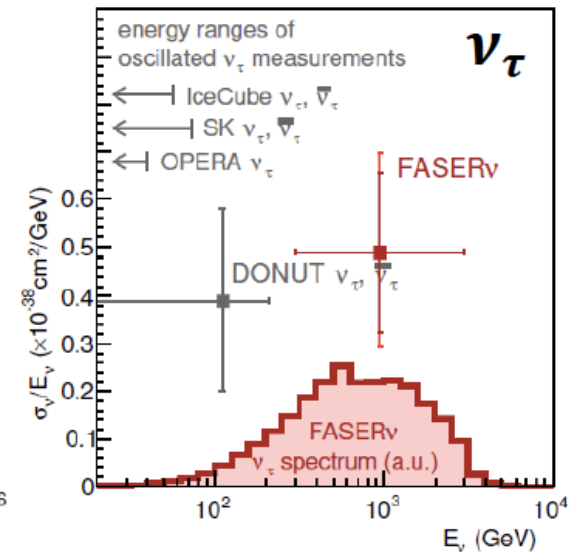
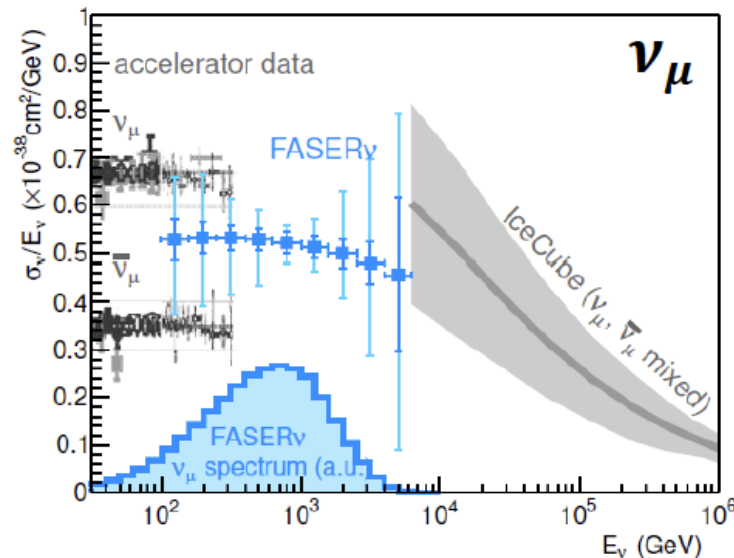
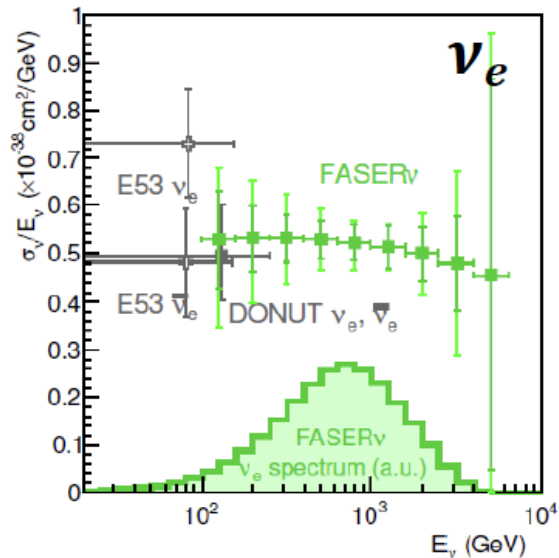

FASER Collaboration 1908.02310 (2019)





# FORWARD PHYSICS FACILITY

---

- FASER, FASER<sub>v</sub>, and SND@LHC are currently highly constrained by 1980's (LEP!) infrastructure that was never intended to support experiments.
- The rich physics program in the far-forward region therefore strongly motivates creating a dedicated Forward Physics Facility to house far-forward experiments for the HL-LHC era from 2029-2040.
- FPF Meetings
  - FPF Kickoff Meeting, 9-10 Nov 2020, <https://indico.cern.ch/event/955956>
  - FPF2 Meeting, 27-28 May 2021, <https://indico.cern.ch/event/1022352>
  - FPF3 Meeting, 25-26 Oct 2021, <https://indico.cern.ch/event/1076733>
  - FPF4 Meeting, 31 Jan-1 Feb 2022, <https://indico.cern.ch/event/1110746>
- FPF Short Paper: 75 pages, 80 authors completed in Sep 2021 ([2109.10905](https://arxiv.org/abs/2109.10905), Physics Reports 968, 1 (2022)).
- FPF Snowmass White Paper: Feng, Kling, Reno, Rojo, Soldin et al. A comprehensive, 429-page, 392-author+endorser summary ([2203.05090](https://arxiv.org/abs/2203.05090)).

# THE LOCATION

- The CERN civil engineering team has considered many sites around the LHC ring that are on the beam collision axis of an IP.
- A preferred location has been identified ~620-680 m west of the ATLAS IP, shielded by ~200 m of rock. The site is on CERN land in France.

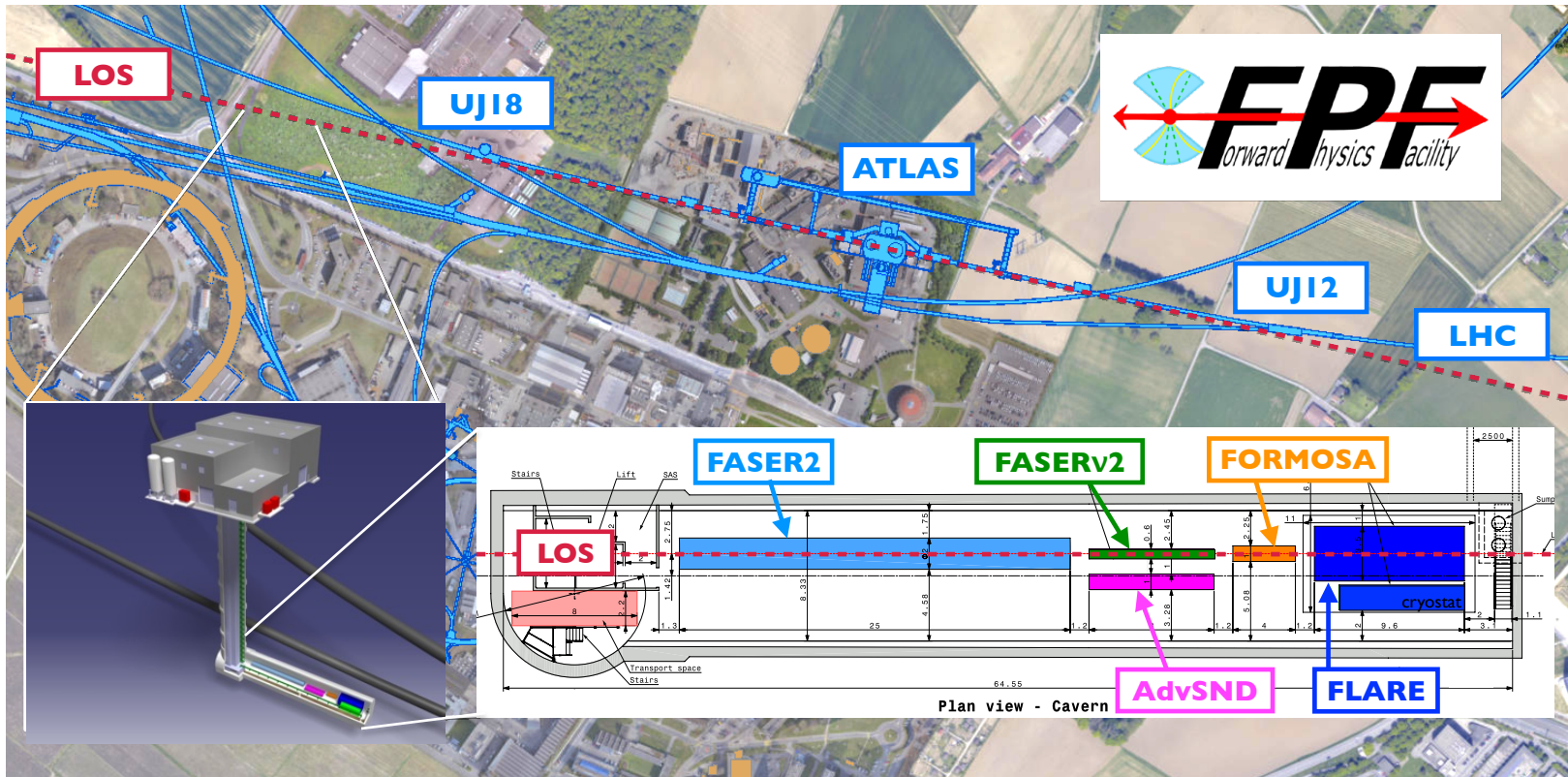

# CAVERN AND SHAFT

- Cavern: 65m long, 8m wide/high. Shaft: 88m-deep, 9.1m-diameter.
- The FPF is completely decoupled from the LHC: no need for a safety corridor connecting the FPF to the LHC, preliminary RP and vibration studies indicate that FPF construction will have no significant impact on LHC operation.

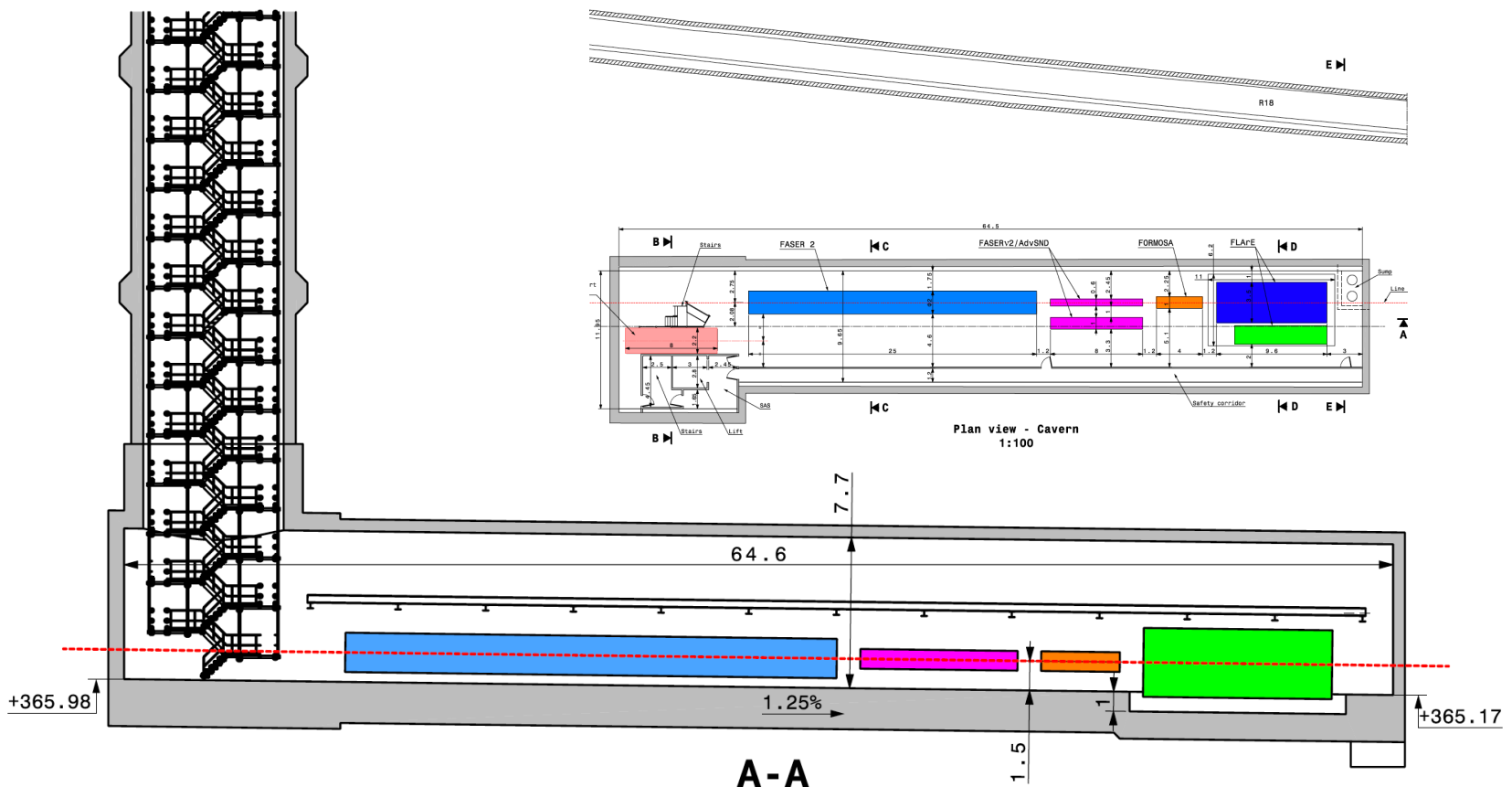

# SURFACE BUILDINGS

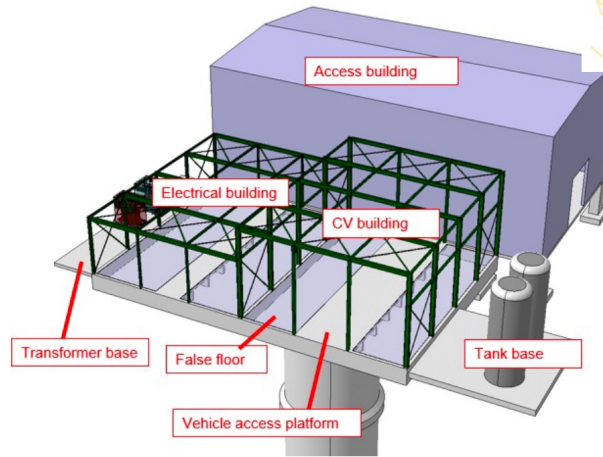
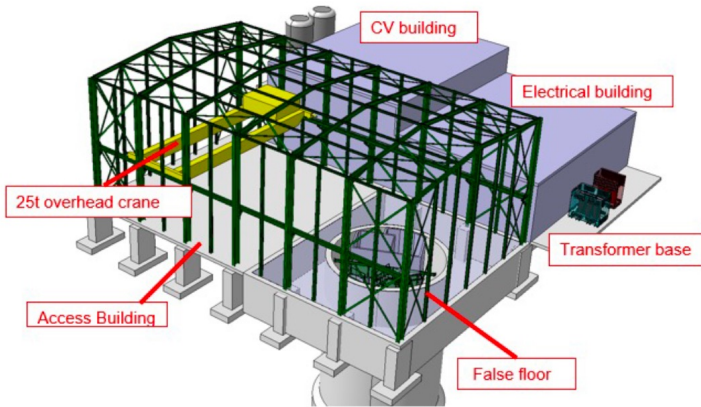
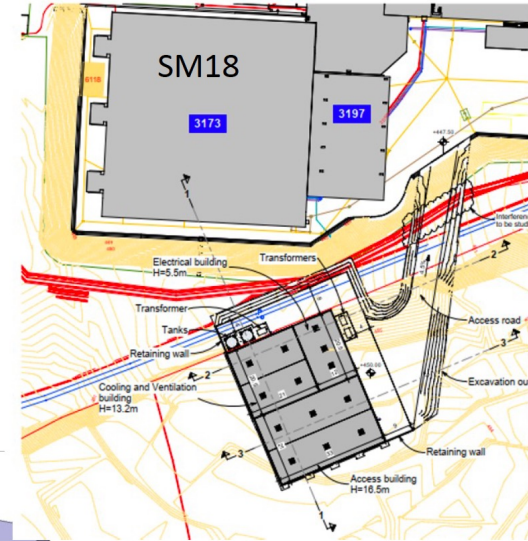
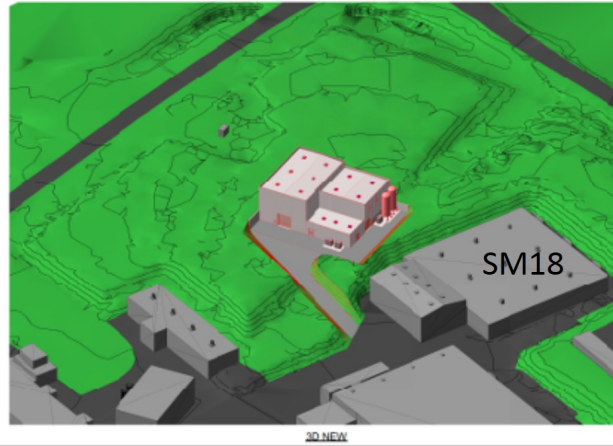
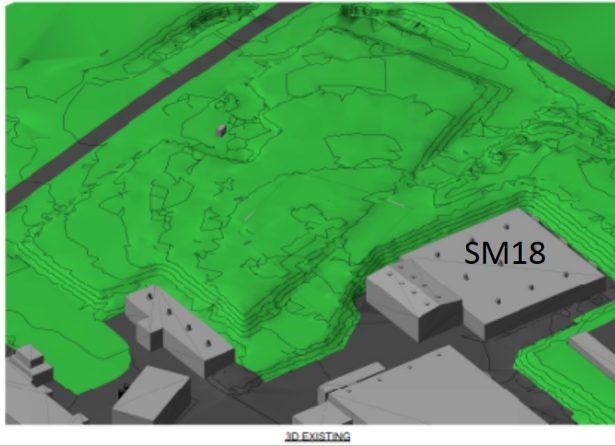

Kincso Balazs,  
John Osborne,  
CERN CE (2022)



# COST AND TIMELINE

- Very preliminary (class 4) cost estimate: 23 MCHF (CE) + 15 MCHF (services)  $\approx$  40 MCHF (+50%/-30%), not including experiments.
- Timeline presented at Chamonix workshop (Feb 2022)

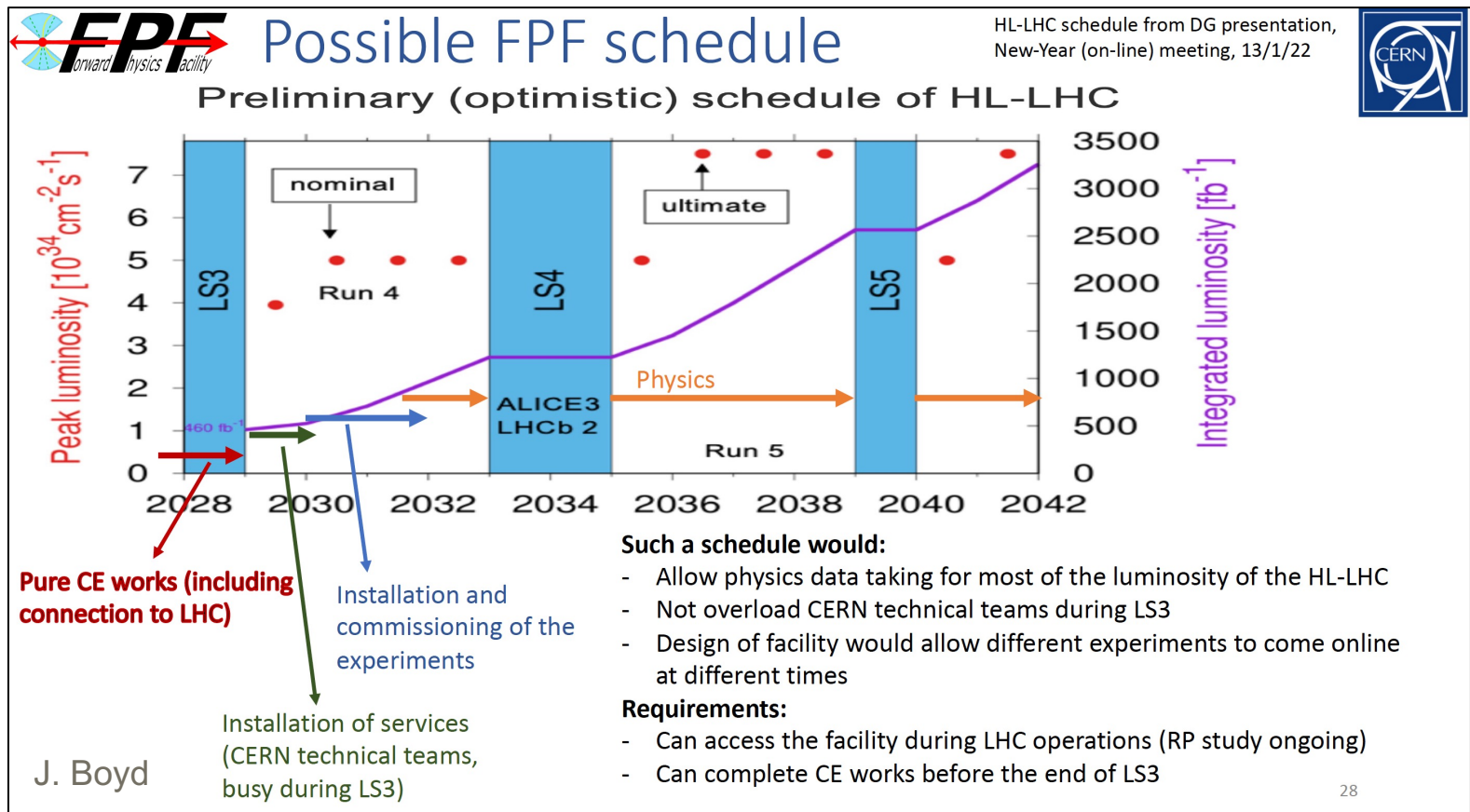

# THE EXPERIMENTS

- At present there are 5 experiments being developed for the FPF; these are works in progress, with much more work to be done.
- Pseudo-rapidity coverage in the FPF is  $\eta > 5.5$ , with most experiments on the LOS covering  $\eta > 7$ .

## FASER2

magnetized spectrometer  
for BSM searches

## FASERv2

emulsion-based  
neutrino detector

## FORMOSA

plastic scintillator array  
for BSM searches

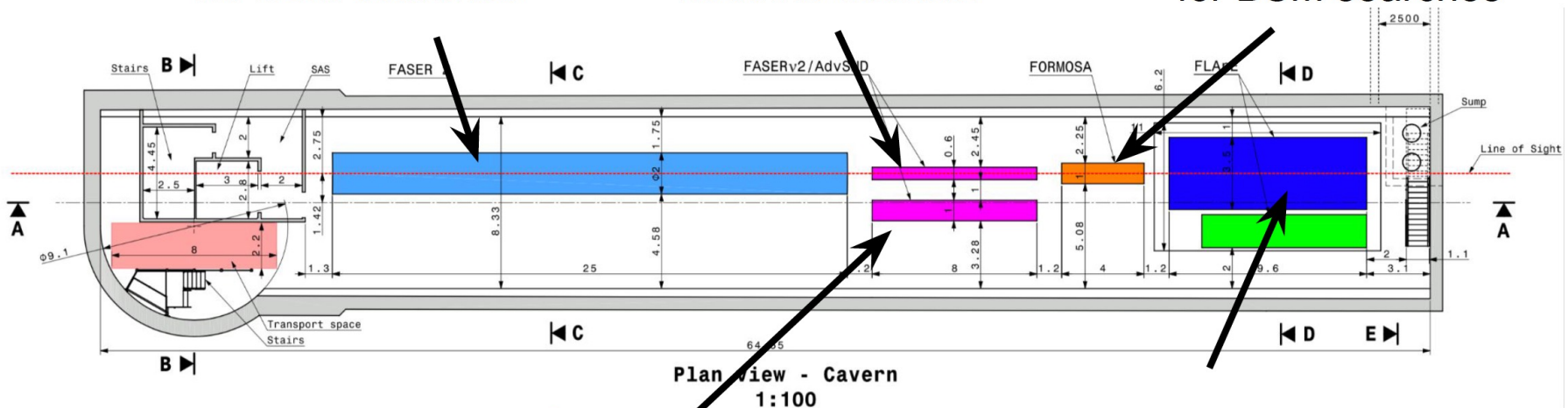

## AdvSND

electronic  
neutrino detector

## FLArE

LAr based  
neutrino detector

Kling (2022)

# THE EXPERIMENTS

- FASER2: upgraded FASER (tracker + magnetic spectrometer) 20 m long, targeting LLPs.
- FASER<sub>v</sub>2, AdvSND: successors to FASER<sub>v</sub> and SND@LHC, ~few to 20 tonne detectors to study TeV neutrinos and differentiate flavors.

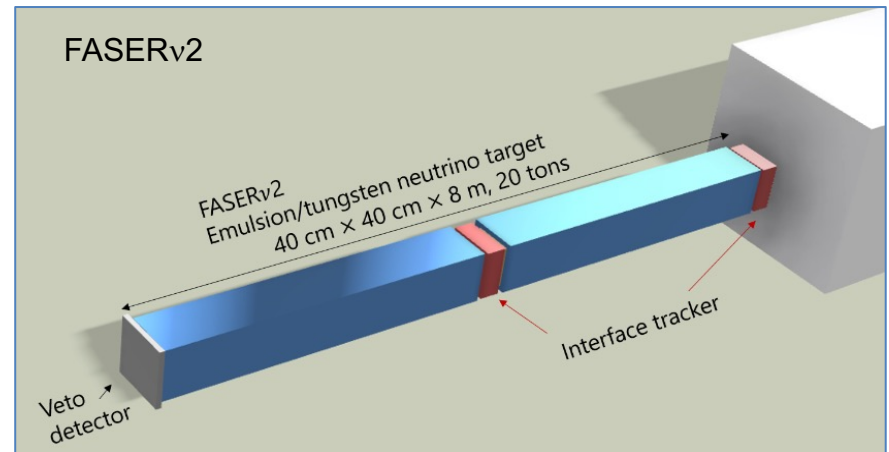
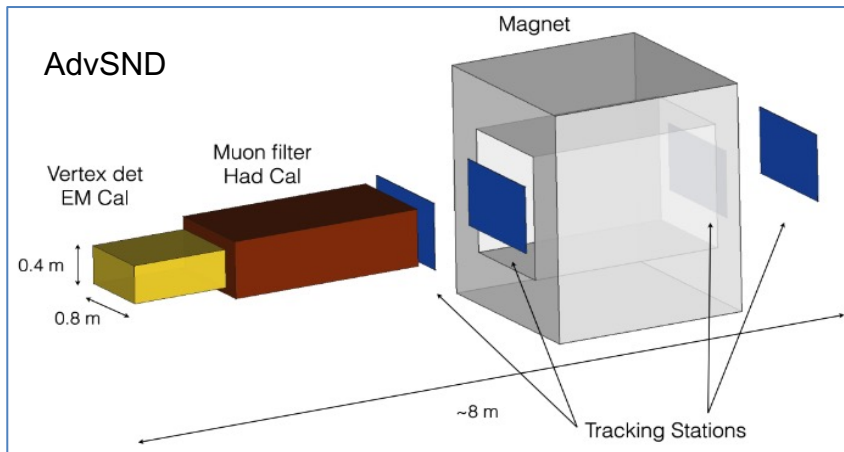
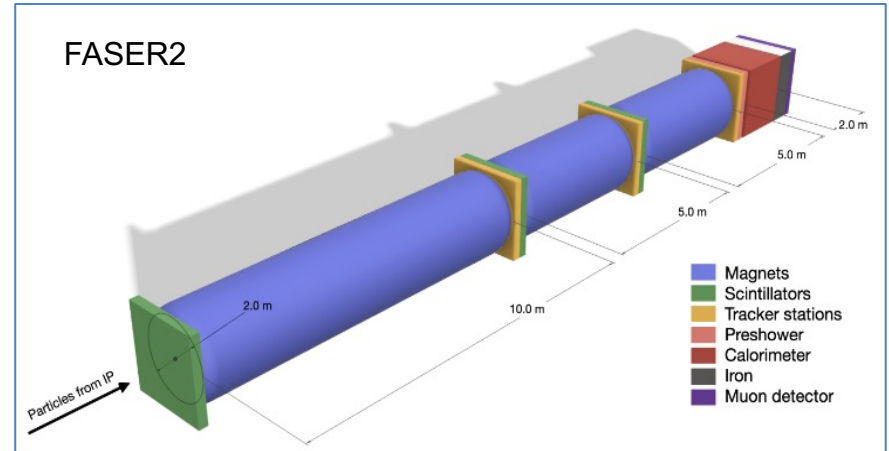

# THE EXPERIMENTS

- FORMOSA: successor to MilliQan, 1m x 1m x 5m scintillator bars + PMTs looking for milli-charged particles, particles with EDMs, MDMs, and similar signatures.
- FLArE: Forward Liquid Argon Experiment, ~1m x 1m x 7m noble liquid (Ar or Kr) TPC for neutrino studies, light DM searches.

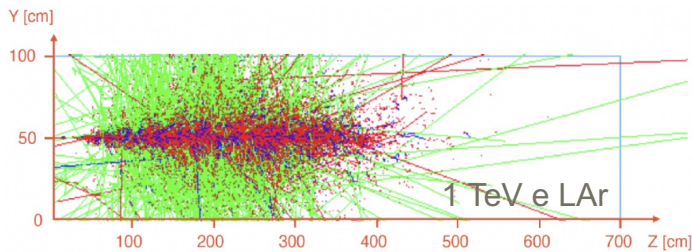
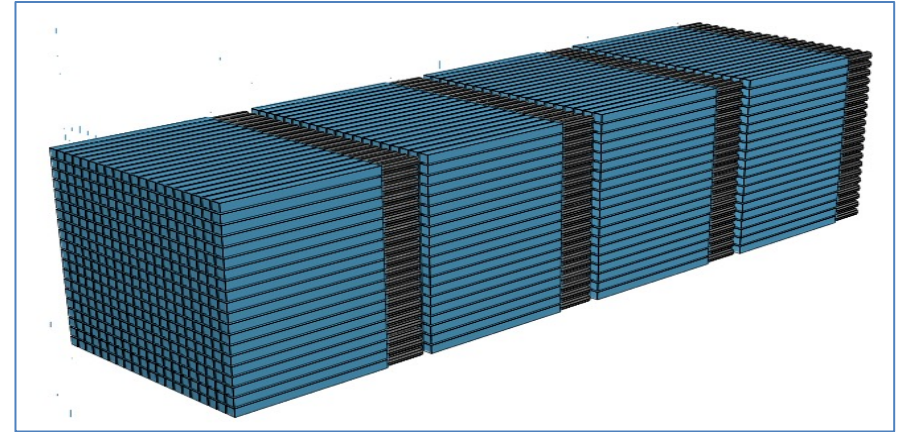

UCI Group (Bian et al.)

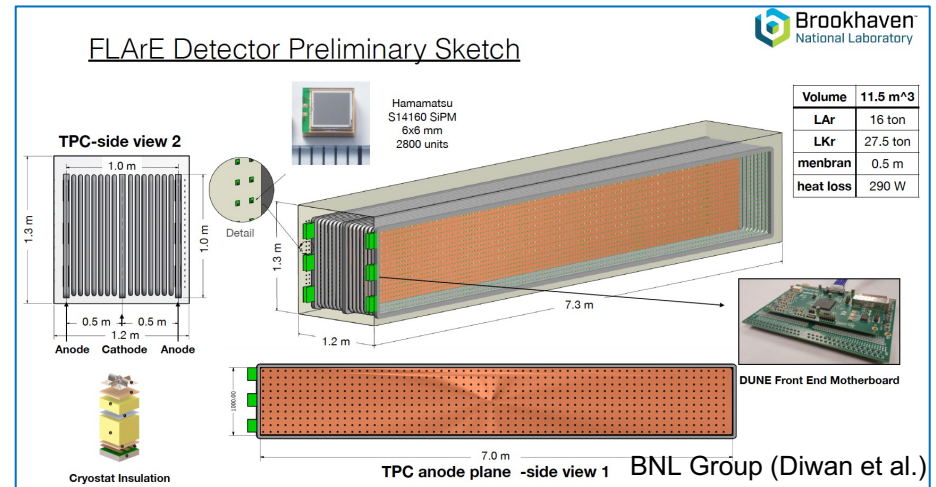
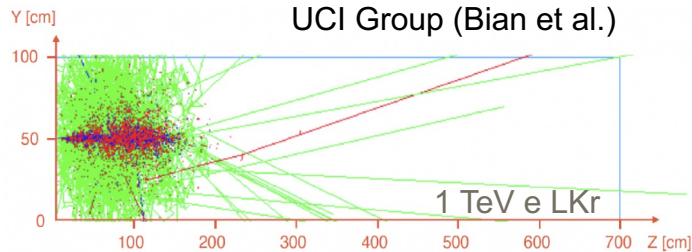



# FPF PHYSICS

- The FPF is a general purpose facility with a broad SM and BSM physics program that expands on the physics of FASER and FASER<sub>v</sub>. Here I will just give a few examples. For more, see the FPF White Paper.

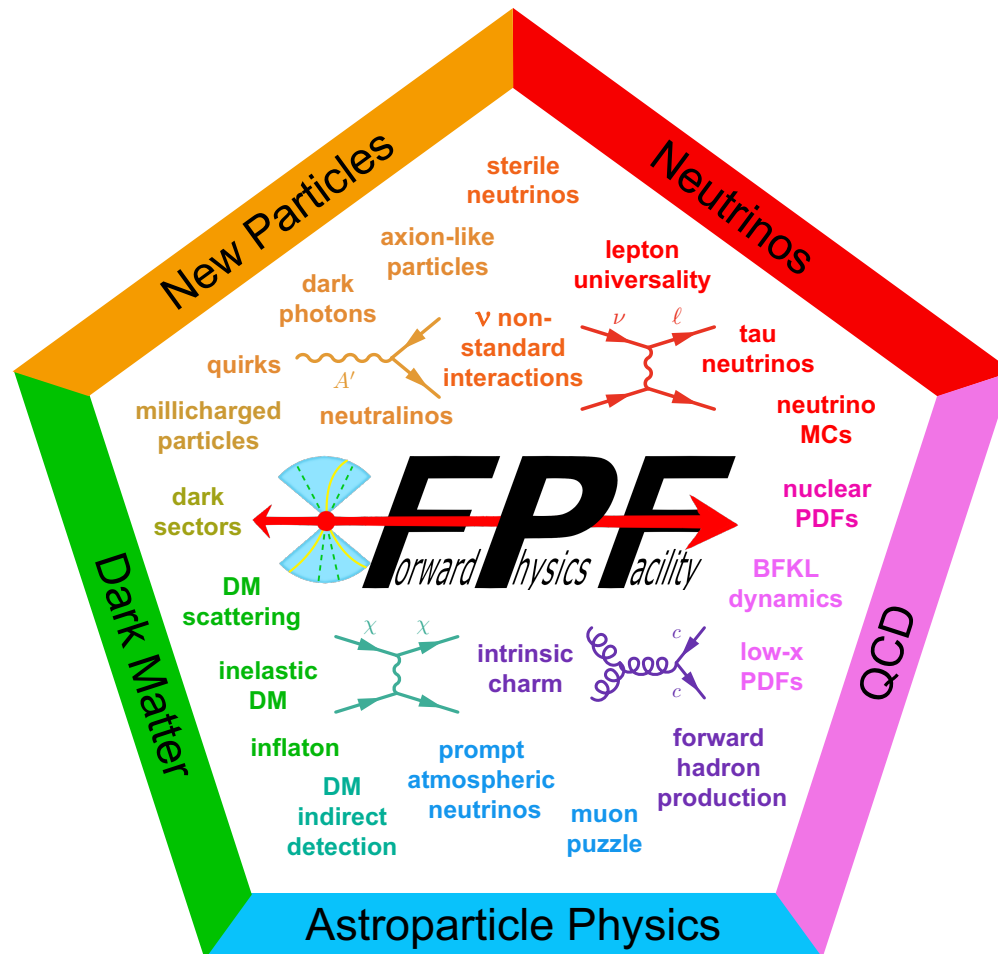

# DARK SECTOR SEARCHES

- The dedicated detectors have significant discovery potential for a wide variety of BSM/LLP models: dark photons; B-L and related gauge bosons; dark Higgs bosons; HNLs with couplings to e, mu, tau; ALPs with photon, gluon, fermion couplings; light neutralinos, inflaton, relaxion, and many others.

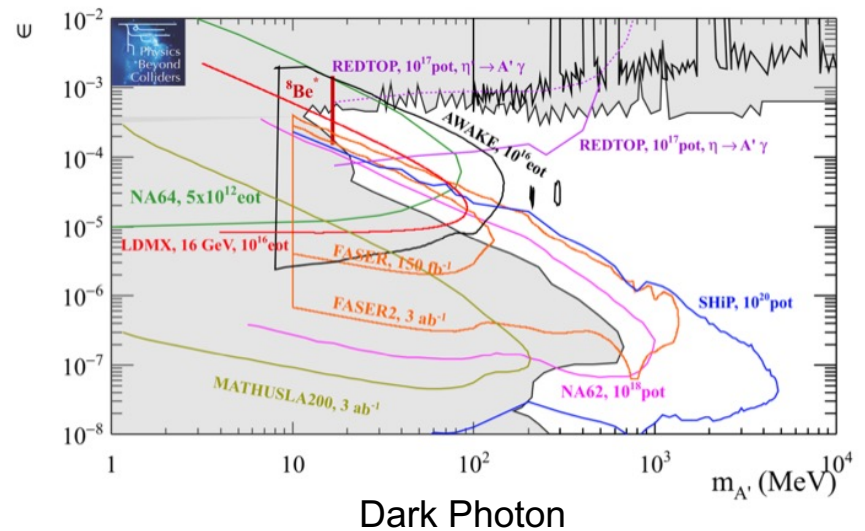

FPF White Paper (2022)

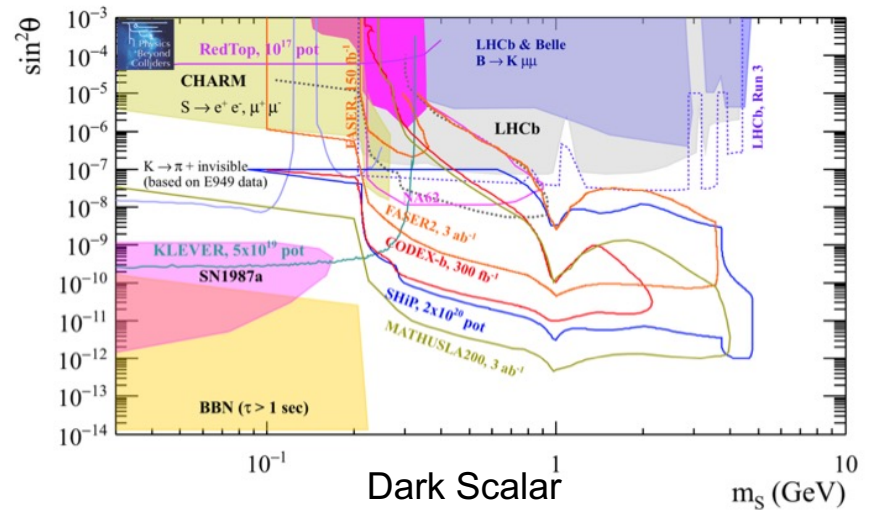
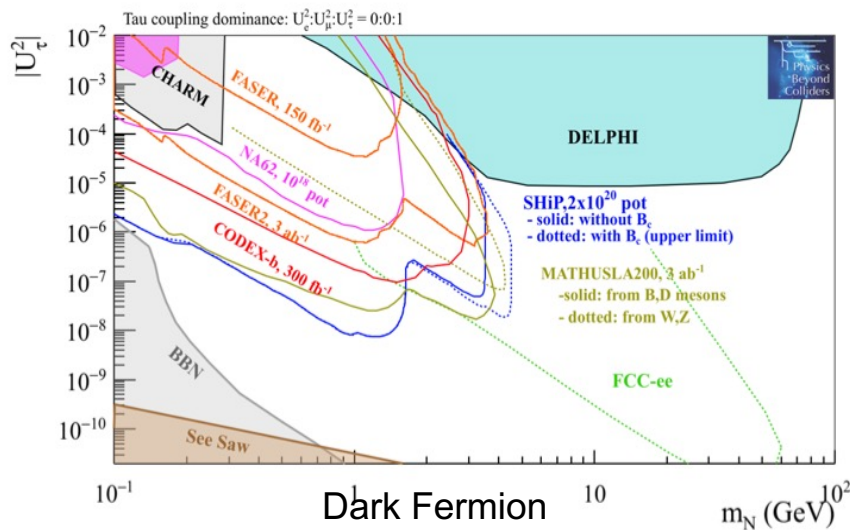

# NEUTRINO PHYSICS AT THE FPF

- At the FPF, three proposed  $\sim 10$ -ton detectors FASER $\nu 2$ , AdvSND, and FLArE will each detect  $\sim 100,000$   $\nu_e$ ,  $\sim 1,000,000$   $\nu_\mu$ , and  $\sim 1000$   $\nu_\tau$  interactions at TeV energies, providing high statistics samples for all three flavors in an energy range that has never been directly explored.
- Will enable precision studies of the tau neutrino.
- Can also distinguish neutrinos and anti-neutrinos for muon and tau.

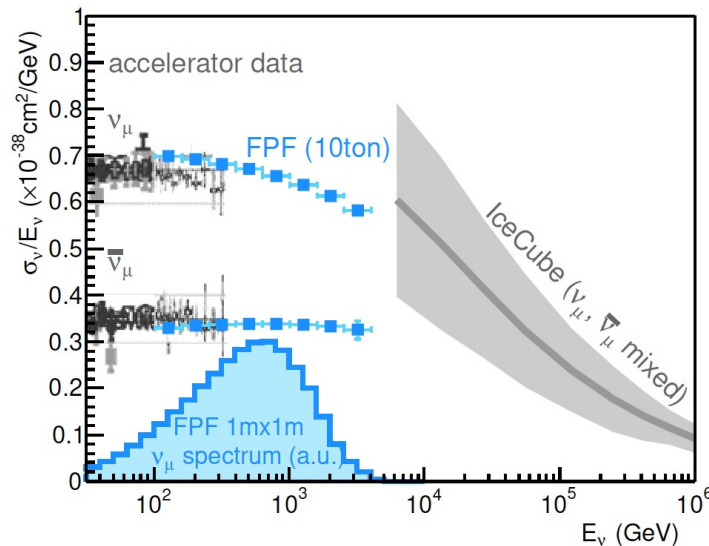
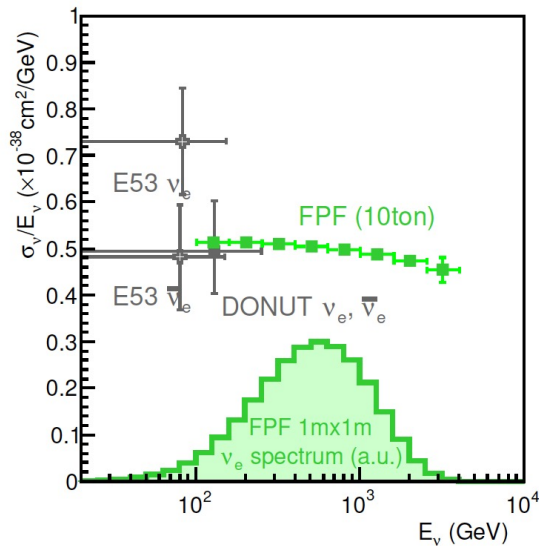

FASER White Paper (2022)

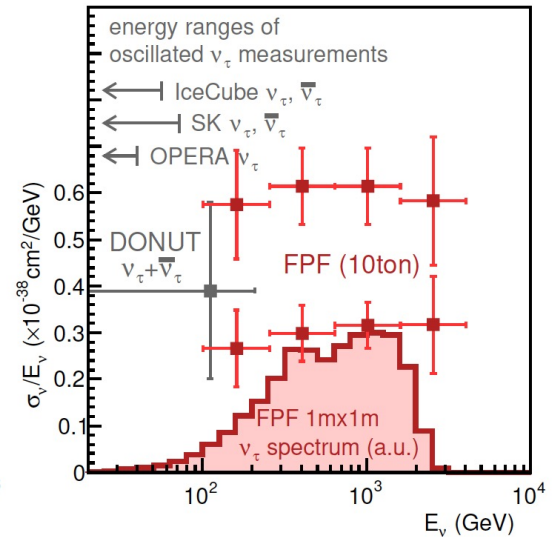

# QCD

- The FPF will also support a rich program of QCD and hadron structure studies.
- Forward neutrino production is a probe of forward hadron production, BFKL dynamics, intrinsic charm, ultra small  $x$  proton structure, with important implications for UHE cosmic ray experiments.
- Neutrino interactions will probe DIS at the TeV-scale, constrain proton and nuclear structure, pdfs.

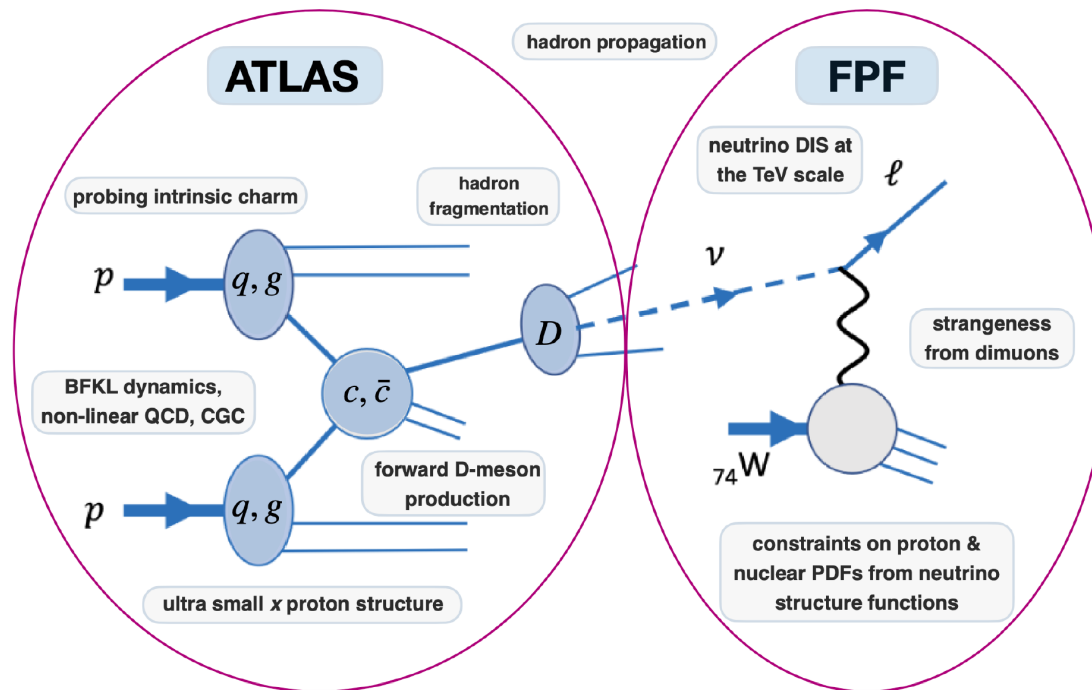



# QCD

- The FPF will probe proton structure at ultra small  $x \sim 10^{-7}$  (and also high  $x \sim 1$ ).
- In addition to the intrinsic interest in QCD, ultra small- $x$  physics will become more and more important at higher energies, for example, in making precise predictions for  $\sigma(gg \rightarrow h)$  at a 100 TeV pp collider.

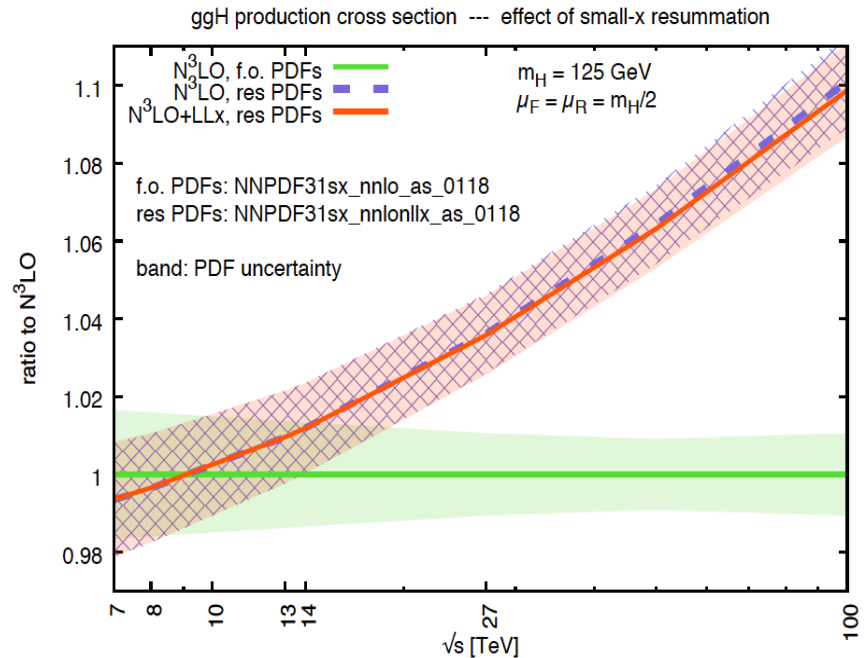
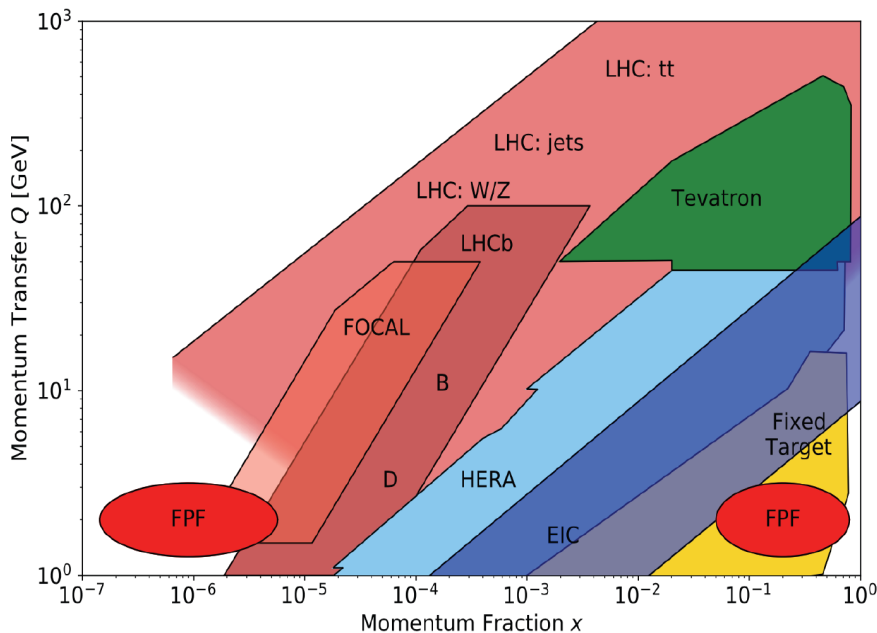

FPF White Paper (2022)

# MILLI-CHARGED PARTICLES

- A completely generic possibility motivated by dark matter, dark sectors. Currently the target of the MilliQan experiment, located at the LHC near the CMS experiment in a “non-forward” tunnel.
- The MilliQan Demonstrator (Proto-MilliQan) already probes new region. Full MilliQan can also run in this location in the HL-LHC era, but the sensitivity may be improved significantly by moving it to the FPF (FORMOSA).

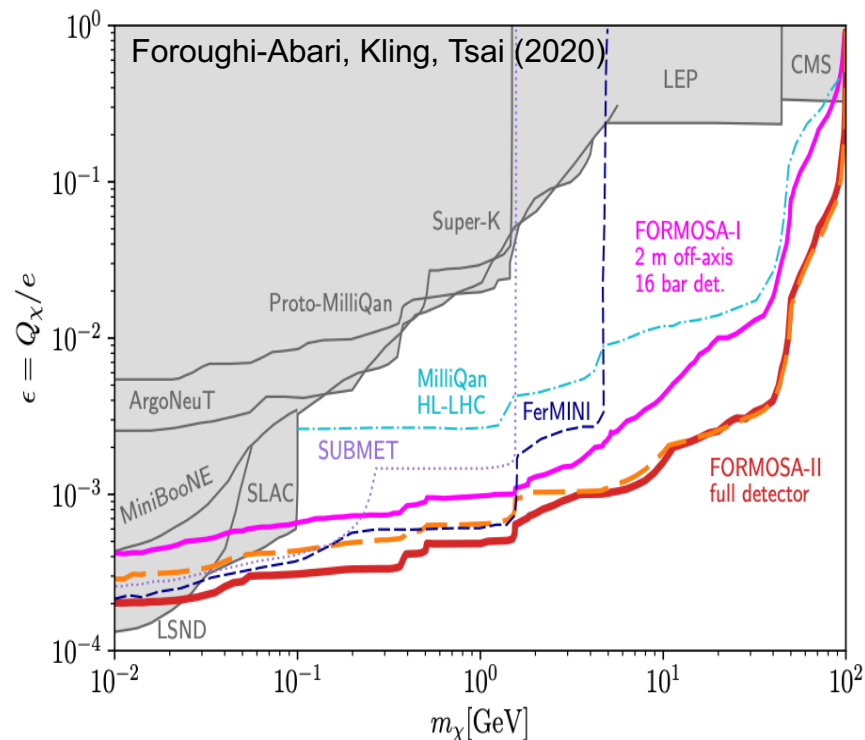

# DARK MATTER DIRECT DETECTION

- Light DM with masses at the GeV scale and below is famously hard to detect.

- Galactic halo velocity  $\sim 10^{-3} c$ , so kinetic energy  $\sim$  keV or below.

- At the LHC, we can produce DM at high energies, look for the resulting DM to scatter in FLArE, Forward Liquid Argon Experiment, a proposed 10 to 100 tonne LArTPC.

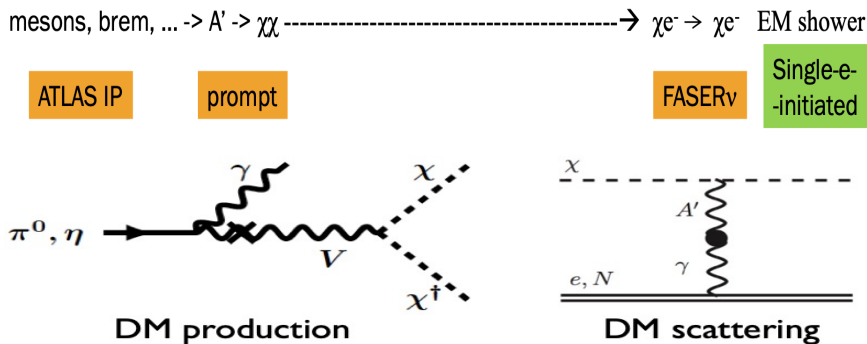

- FLArE is powerful in the region favored/allowed by thermal freezeout.

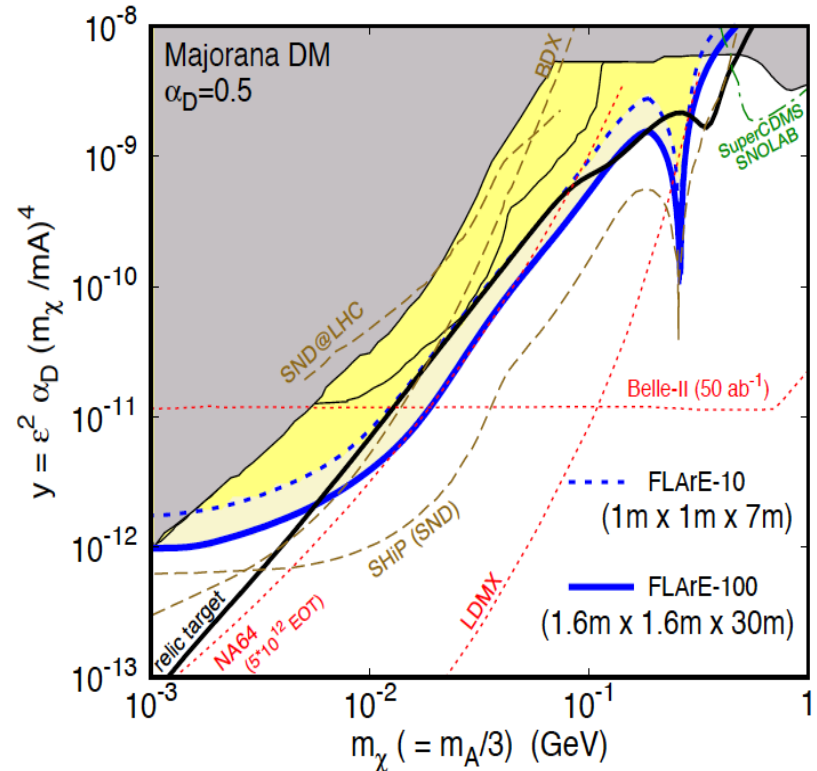
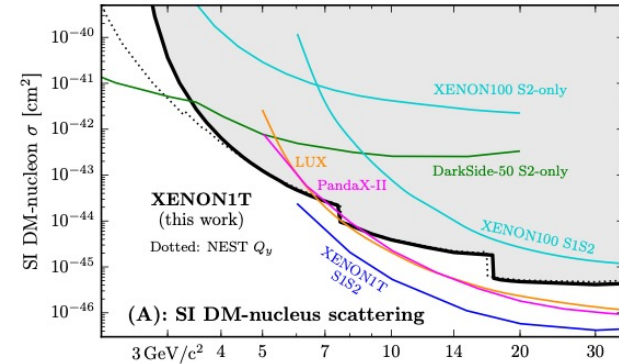

# SUMMARY

- Colliders can look for heavy, strongly-interacting particles and light, weakly-interacting particles; the LHC is currently missing half of these possibilities.
- The FPF is uniquely positioned to fully realize the LHC's physics potential for both SM and BSM physics in the far forward region, greatly extending the LHC physics program for relatively little cost.
- Plan: CDRs for the facility and experiments in the next 12-18 months, construction in LS3, physics in HL-LHC Run 4. Much work to be done!

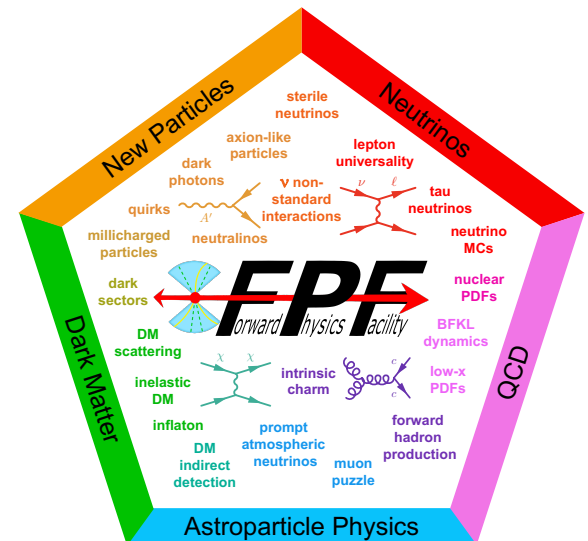
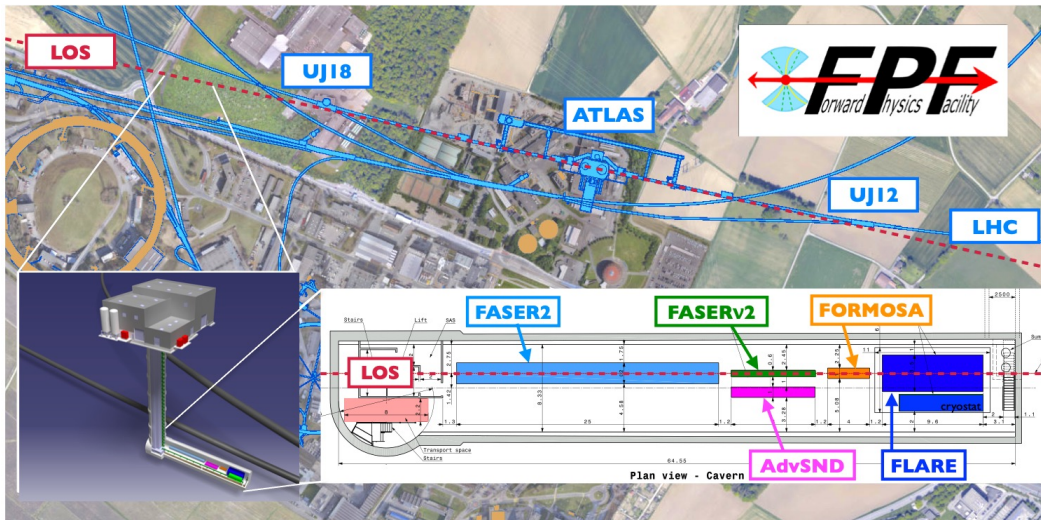



---

# EXTRAS

# FPF CIVIL ENGINEERING

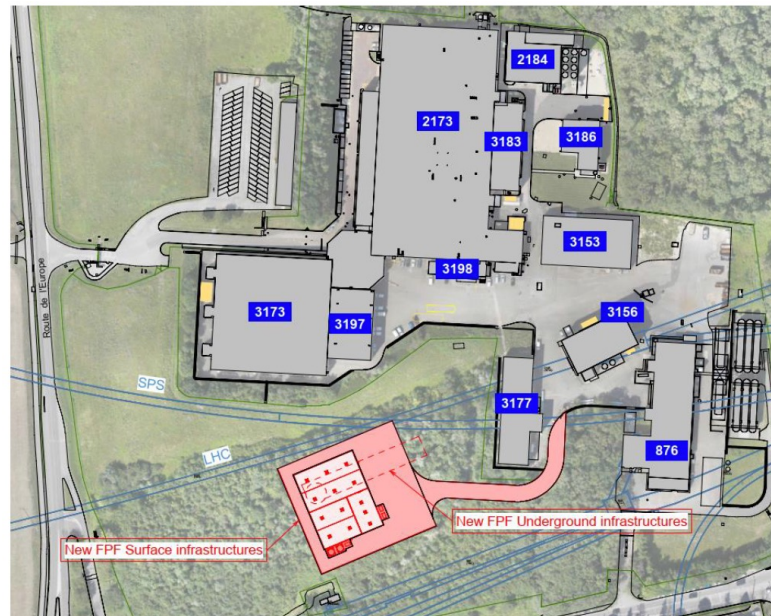
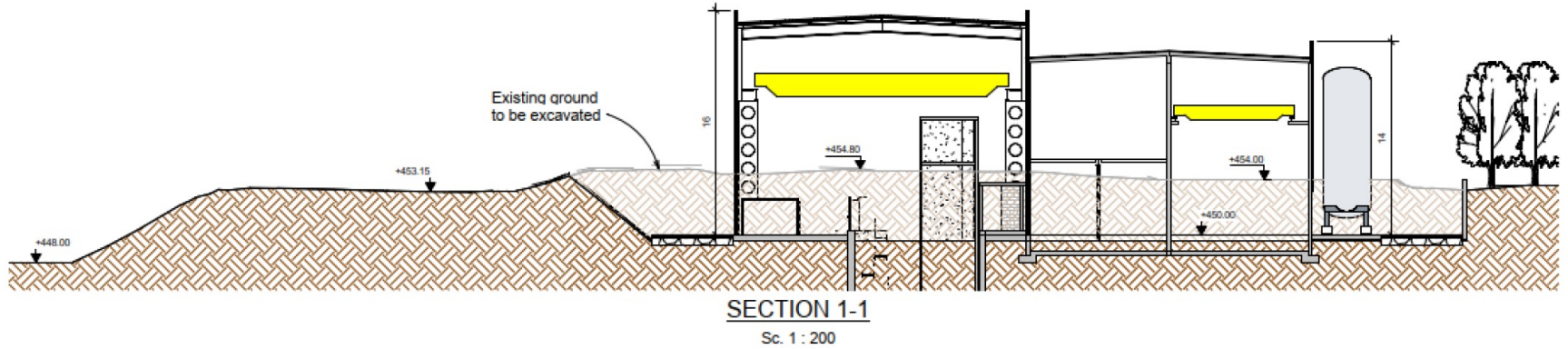

Balazs (2022)

# WHERE THE PIONS ARE

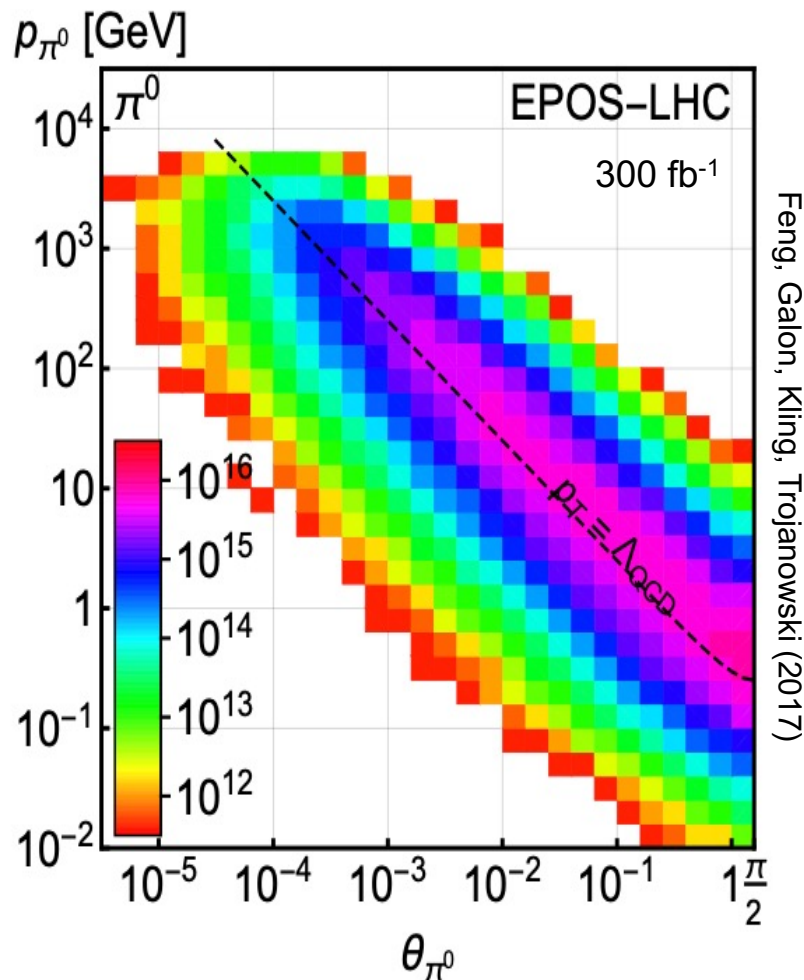
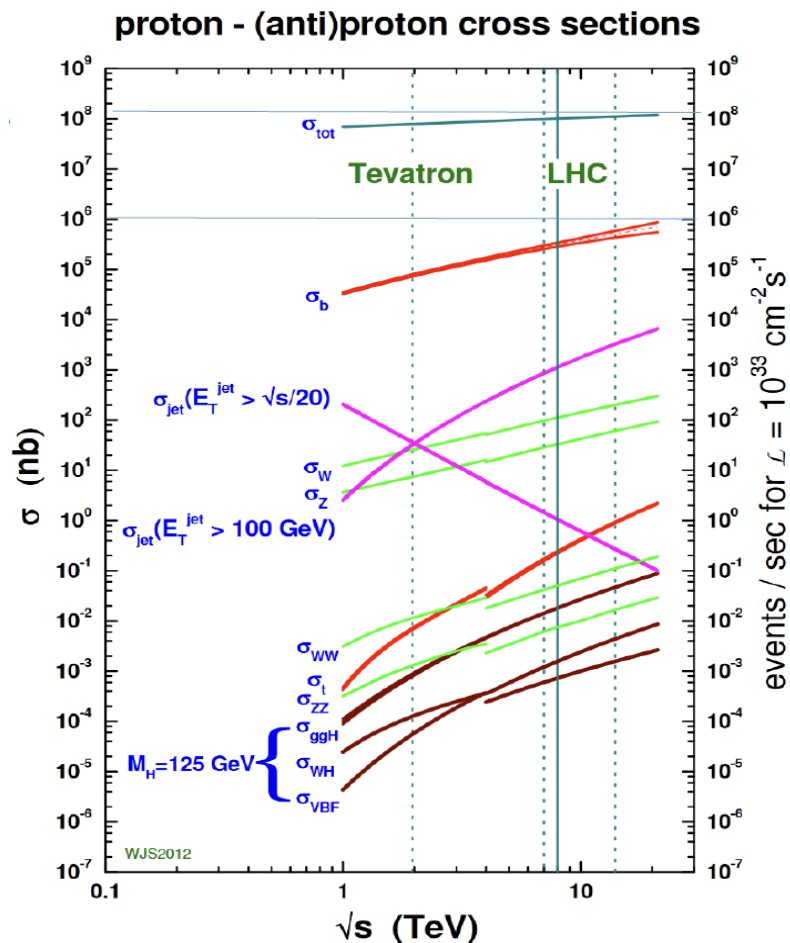

- Enormous  $\sigma_{tot} \sim 100 \text{ mb}$ , currently wasted in BSM searches.

- Pions typically have  $p_T \sim 250 \text{ MeV}$ , but large flux with  $p \sim \text{TeV}$  within 1 mrad ( $\eta > 7.6$ ) of the beamline.

# FPF NEUTRINO DISTRIBUTIONS

Where do the LHC neutrinos come from?

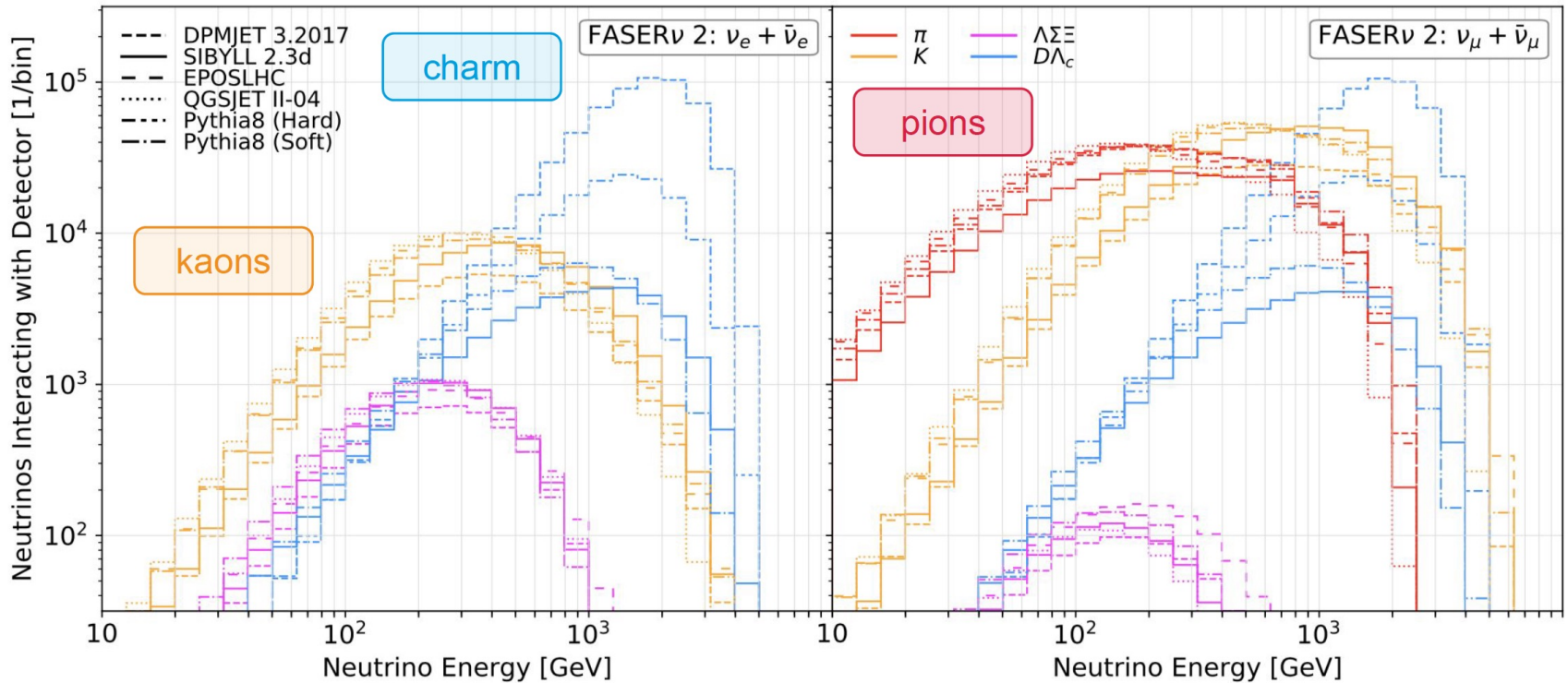

LHC neutrinos = probe of forward particle production

Kling (2022)



# FPF NEUTRINO DISTRIBUTIONS

## Neutrino Fluxes and Rates.

Event rates at LHC neutrino experiments  
estimated with two LO MC generators: SIBYLL / DPMJET

Detector			Number of CC Interactions		
Name	Mass	Coverage	$\nu_e + \bar{\nu}_e$	$\nu_\mu + \bar{\nu}_\mu$	$\nu_\tau + \bar{\nu}_\tau$
LHC Run3	FASER $\nu$	1 ton $\eta \gtrsim 8.5$	1.3k / 4.6k	6.1k / 9.1k	21 / 131
	SND@LHC	800kg $7 < \eta < 8.5$	180 / 500	1k / 1.3k	10 / 22
HL-LHC	FASER $\nu$ 2	20 tons $\eta \gtrsim 8$	178k / 668k	943k / 1.4M	2.3k / 20k
	FLArE	10 tons $\eta \gtrsim 7.5$	36k / 113k	203k / 268k	1.5k / 4k
	AdvSND	2 tons $7.2 \lesssim \eta \lesssim 9.2$	6.5k / 20k	41k / 53k	190 / 754

Large spread in current generator predictions

### Challenge:

For neutrino physics measurement  
we need to quantify and reduce  
neutrino flux uncertainties

### Opportunity:

Forward neutrino flux measurement  
can help to improve our  
understanding of underlying physics.

Kling (2022)

# FPF MUON BACKGROUND FROM FLUKA

- In order to get the muon fluence in the FPF cavern:

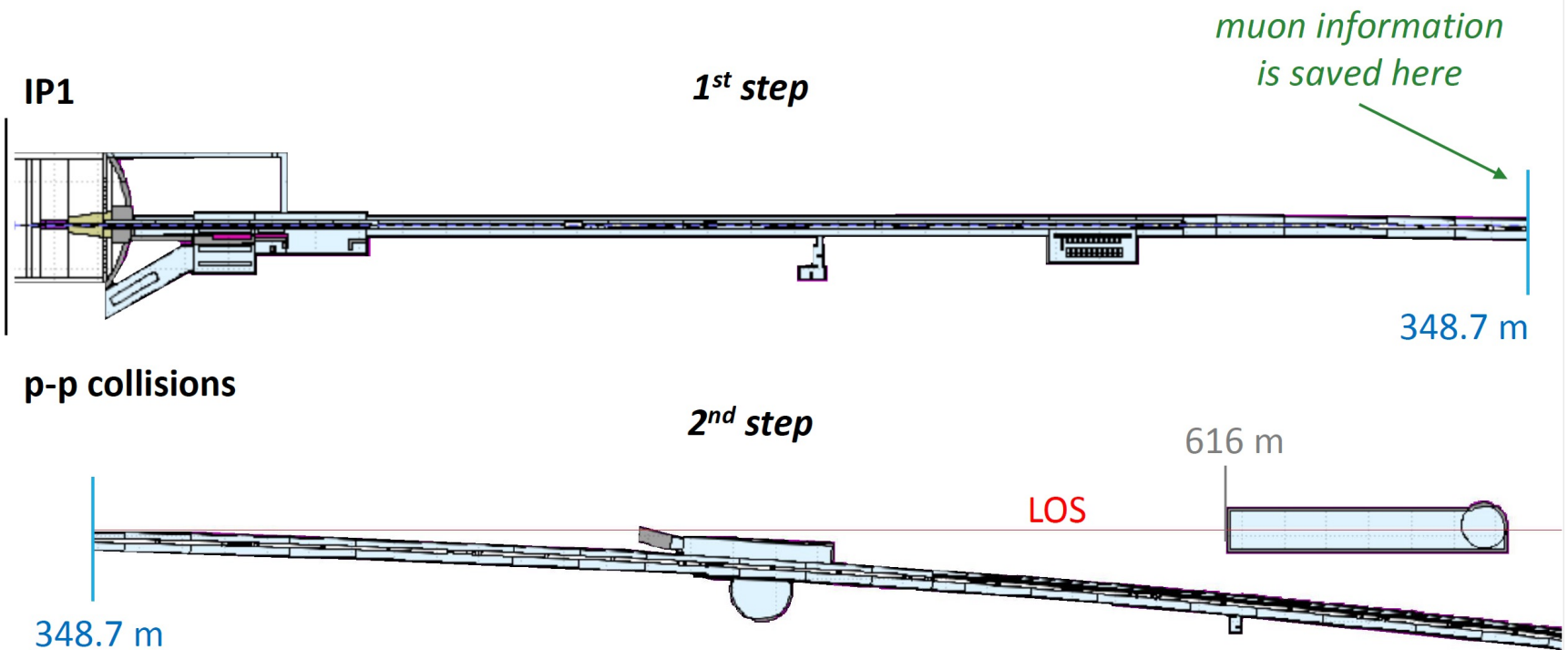

Cerutti, Sabate-Gilarte (2022)

# FPF MUON BACKGROUND FROM FLUKA

## Muon fluence in FPF cavern

- Result from 2<sup>nd</sup> step simulation.

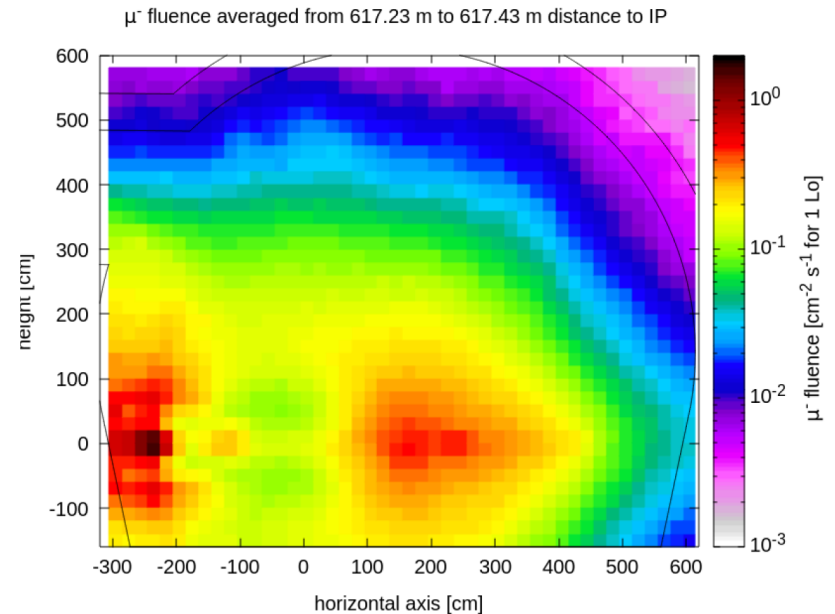
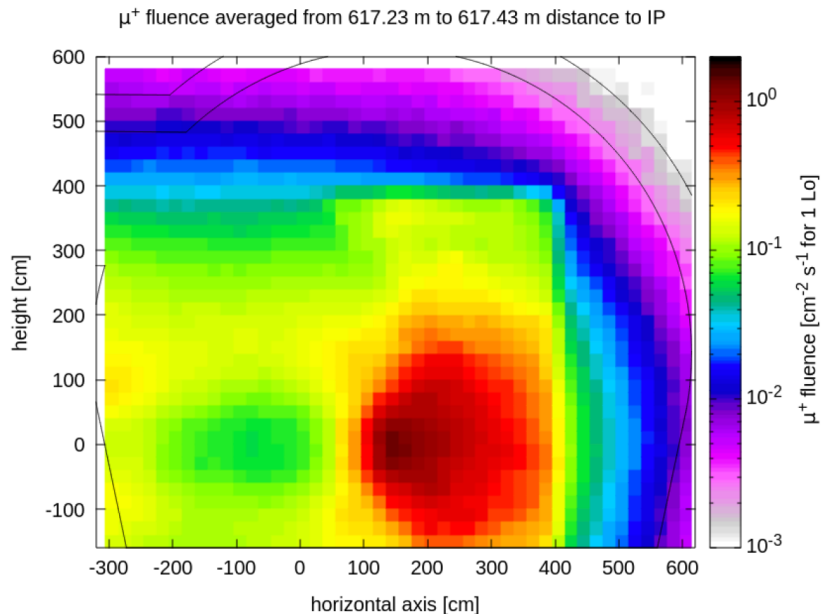

Cerutti, Sabate-Gilarte (2022)