

Cryogenics for Superconducting Quantum Information Science

Matthew Hollister
USQIS Summer School
August 8, 2023

Introduction

Objective: To understand the physics behind the dilution cooling process, be familiar with the design features of modern refrigerators, and to have an introductory understanding of cryogenic engineering considerations at millikelvin temperatures.

Outline:

- Background
- Physics of helium and the behavior of $^3\text{He}/^4\text{He}$ mixtures
- Making a practical refrigerator
- The development of dilution refrigerators from the 1960s to today
- Modern designs and operation
- Materials and design techniques at mK temperatures

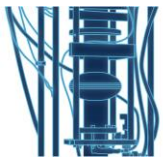

Cryogenics Primer

- Cryogenics is defined as temperatures below 120 K.
- Why 120 K? It is possible to generate temperatures of 120 K by simple expansion of a working fluid starting from ambient temperatures. Temperatures below 120 K can only be produced with additional heat exchange prior to expansion.
- Simple refrigeration can be achieved with liquid cryogenics (common examples are liquid nitrogen at 77 K or liquid helium at 4 K, both at atmospheric pressure).
- At the other end of the scale, the current record low temperature is 280 pK (0.00000000028 K).

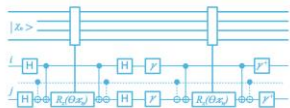
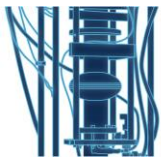

Why cryogenics in the context of quantum technologies?

- Operating a system such as an electronic device at cryogenic temperatures allows us to take advantage of low temperature phenomena, such as reduced Johnson noise or superconductivity.
- Cryogenic environments are also very useful for reducing external noise sources, very important in many quantum systems where external energy inputs can upset the quantum states.
- Likely the most common application of cryogenics with quantum technologies you will have seen are the superconducting devices at companies like Rigetti and others operating at mK temperatures in dilution refrigerators.

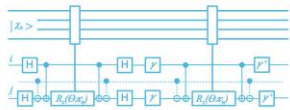
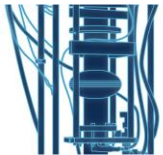

Why use dilution refrigerators?

- Dilution refrigerators, based on the heat of mixing of Helium-3 and Helium-4, are the only viable cooling technology that can reach millikelvin temperatures while providing continuous cooling.
- Other refrigerators such as adiabatic demagnetization of paramagnetic salts can cool to below 100 mK, but the process is discontinuous. Can be useful for screening of devices or material studies, but less so for device testing.
- Helium evaporation fridges can reach 0.3 K (Helium 3) or 0.8 K (Helium 4), which can be useful for sensors such as SNSPDs

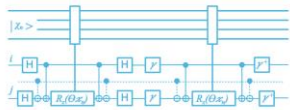
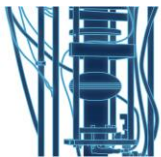

Physics of Helium and Helium Mixtures

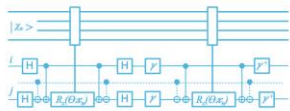
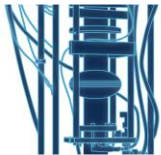

Helium mixtures

- Important to note that Helium-4 obeys Bose statistics. Superfluid transition occurs at 2.18 K. Helium-3 obeys Fermi statistics, obeys the Pauli principle and has a superfluid transition near 1 mK.
- In the following discussions, the respective concentrations of the two helium isotopes are expressed as

$$x = x_3 = \frac{n_3}{n_3 + n_4}$$

$$x_4 = \frac{n_4}{n_3 + n_4}$$

where n_3 and n_4 are the number of atoms or the number of moles of ^3He and ^4He , respectively.

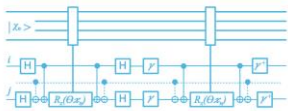
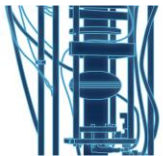

Phase diagram and solubility

Diluting 3He into 4He depresses the superfluid transition temperature

Superfluid transition disappears completely for $x > 67.5\%$

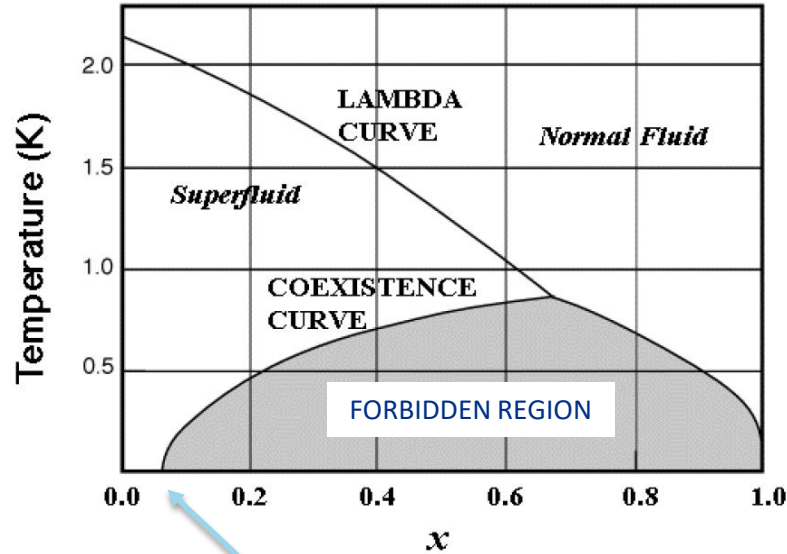

Finite solubility – on the 4He-rich side, the concentration does not go to zero at $T=0$

As a mixture with $x > 6.6\%$ is cooled, it will separate into 2 phases.

One phase (the “concentrated phase”) will approach $x=100\%$, the other (the “dilute phase”) will approach $x = 6.6\%$.

This finite solubility and phase separation is key to the dilution refrigerator process

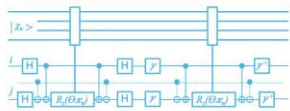
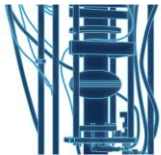

Phase separation at low temperature

4He-rich phase
Higher density

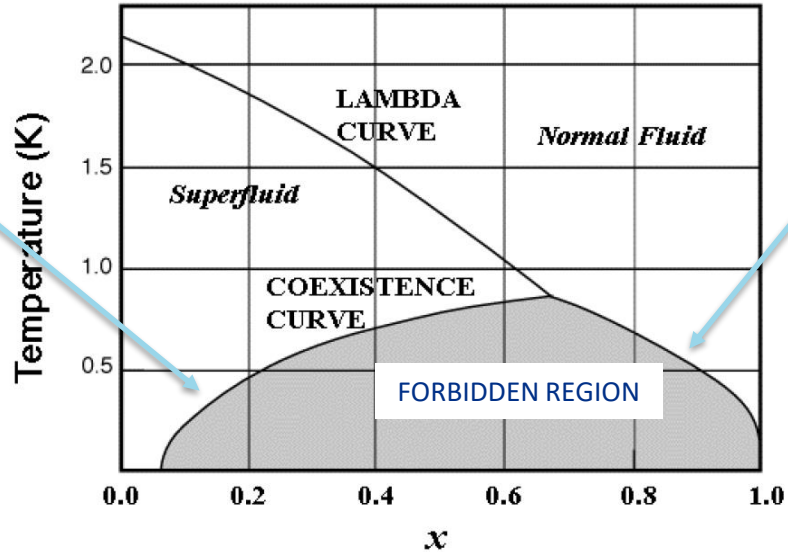

3He-rich phase
(essentially pure 3He)

Lower density, floats
on top of the 4He-rich
phase

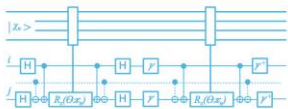
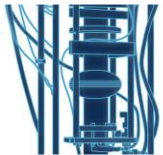

3He-4He mixtures as Fermi liquids

- As mentioned, 4He obeys Bose statistics and will condense into the quantum mechanical ground state at low enough temperature.
- **In a helium mixture, the condensed 4He acts as an “inert superfluid background”** which contributes to the volume of the liquid and the effective mass of the 3He atoms but has zero heat capacity.
- The 3He obeys Fermi statistics and will behave in a similar way to conduction electrons in a metal. However, whereas conduction electrons have a Fermi temperature of ~ 10000 K, the Fermi temperature of the 3He is ~ 1 K.

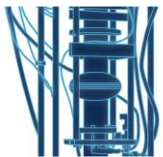

Finite solubility

- Let us consider whether a ^3He atom at the phase separation line would “prefer” to be in the ^3He phase or be in the ^4He -rich phase. The ^3He will go into the phase with the larger binding energy.
- For ^3He atoms in pure ^3He , the binding energy is the latent heat of evaporation.
- For ^3He atoms in ^4He , although the van der Waals forces between ^4He and ^3He are identical, the ^3He atoms have larger zero-point motion due to their smaller mass.
 - The ^4He atoms occupy a smaller volume than the ^3He atoms, so ^3He atoms will feel a stronger attraction to a ^4He atom.

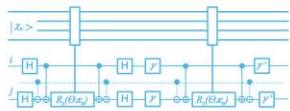
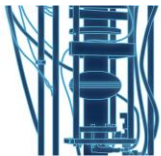

Finite solubility (continued)

- As more ^3He atoms enter the ^4He phase, two effects occur:
 - The larger zero-point motion of the ^3He means that the liquid near the ^3He atoms is more dilute than near ^4He atoms, and the ^3He atoms will tend to group. Binding energy of the ^3He atoms will increase with increasing x_3 .
 - The ^3He atoms must obey the Pauli principle, so additional ^3He atoms must occupy successively higher energy states. Binding energy of the ^3He atoms will decrease with increasing x_3 .
- The first effect is dominant – as x_3 increases, the binding energy of ^3He in ^4He approaches the binding energy of ^3He in ^3He , and an equilibrium is reached.
- This is true even at $T = 0$, hence the finite solubility effect.

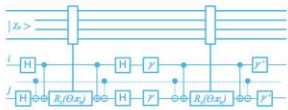
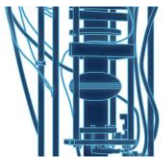

Cooling power of the dilution refrigerator

- Measurements of the specific heat shows that the enthalpy of ^3He in the dilute phase is larger than in the concentrated phase. Moving ^3He from the concentrated to the dilute phase will result in cooling due to the heat of mixing

$$\dot{Q}(T) = \dot{n}_3(H_d(T) - H_c(T))$$

- We won't work through the full derivation here, but in summary

$$H_3(T) = H_3(0) + 11T^2$$

$$H_{3,d}(T) = H_3(0) + 95T^2$$

This result is correct to a few % for $T < 40$ mK

$$\dot{Q}(T) = 84\dot{n}_3T^2$$

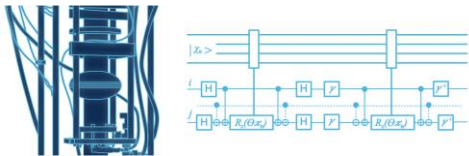

Cooling power – things to note

- The equation giving the cooling power is for the liquid in the mixing chamber. It takes no account of the Kapitza resistance between the liquid and the chamber itself, or the contact resistance between the chamber and any external equipment such as a cold plate.
- Derivation assumes that the ^3He in the concentrated and dilute phases are at the **same temperature**. In reality, the precooling of the inflowing ^3He won't be perfect, so we modify the derivation to account to T_N , the temperature of the ^3He leaving the last heat exchanger:

$$\dot{Q} = \dot{n}_3(96T_{mc}^2 - 12T_N^2)$$

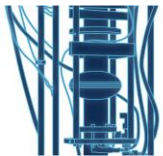

Osmotic pressure

- The osmotic pressure of the Helium mixture is a function of temperature and ^3He concentration (see plot right from Betts, 1989).
- We will discuss this in more detail in the next section, but if we pump ^3He away from the dilute phase the concentration will be reduced, resulting in a difference in the osmotic pressure and driving the flow of ^3He .

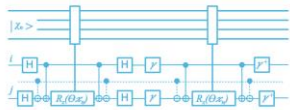
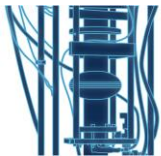
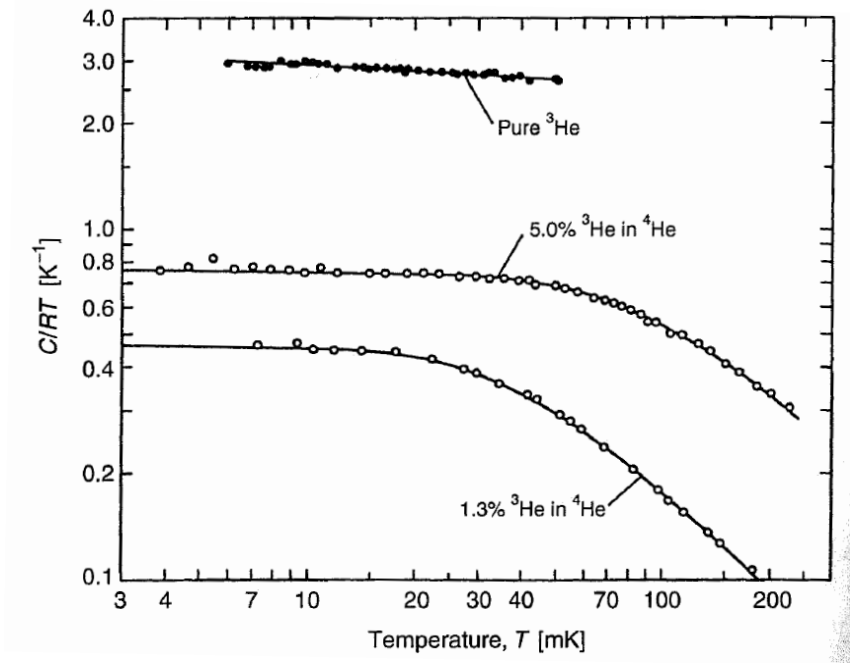

Building a Refrigerator

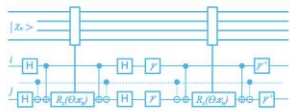

General layout of a dilution refrigerator

- Simplest model for the refrigerator is a U-tube, with the concentrated phase on one side and the dilute side on the other.
- As observed previously, the less dense concentrated phase floats on top of the dilute phase since the superfluid has much higher density.
- Removing ^3He from the dilute phase surface upsets the equilibrium.

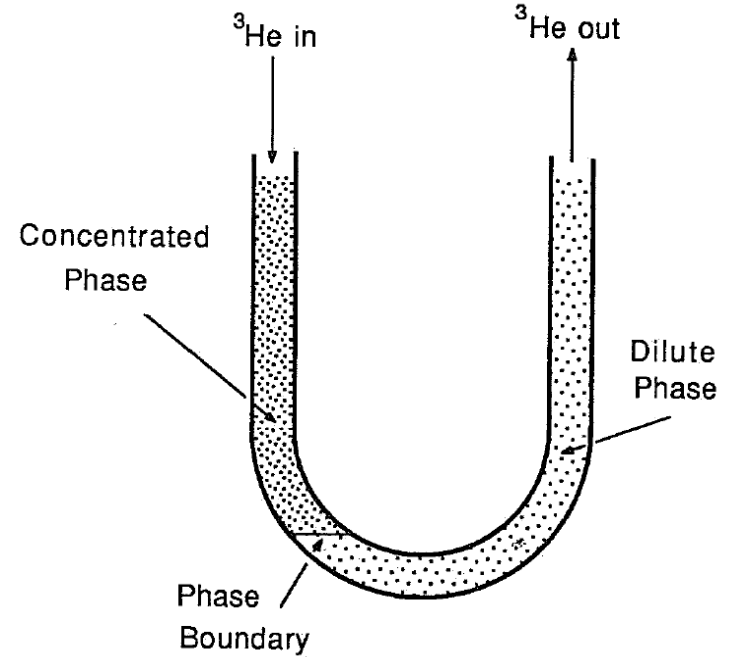

From Richardson & Smith (1998)

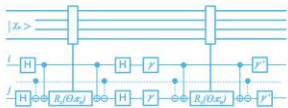
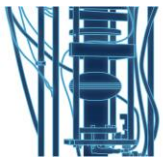

General refrigerator layout

- Major components of a generalized dilution refrigerator shown in the diagram.
- ^3He from the room temperature pump system is cooled and liquified above (or at) the still.
- Cooled further on the way to the mixing chamber.
- ^3He is pumped away from the still.

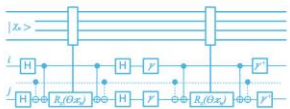
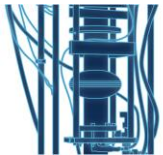
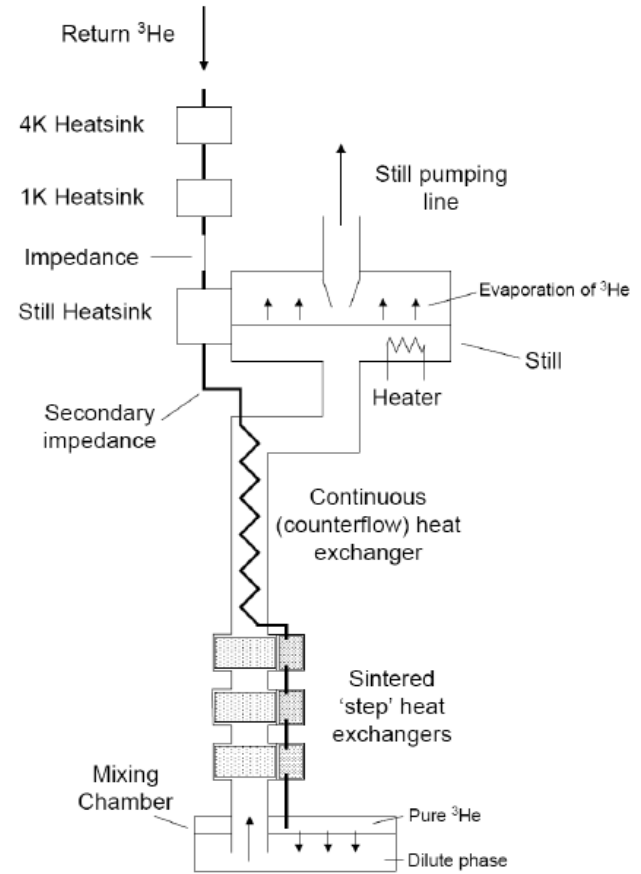

Heat exchanger design above 50 mK

- At higher temperatures, continuous heat exchangers work well. These are typically of the concentric (or coil-in-tube) configuration.
- Heat is transferred from the dilute phase in the annular space and the concentrated phase in the coiled capillary.
- Heat transfer along the fluid and the capillary are negligible.

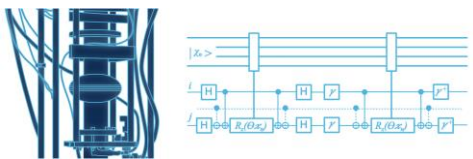
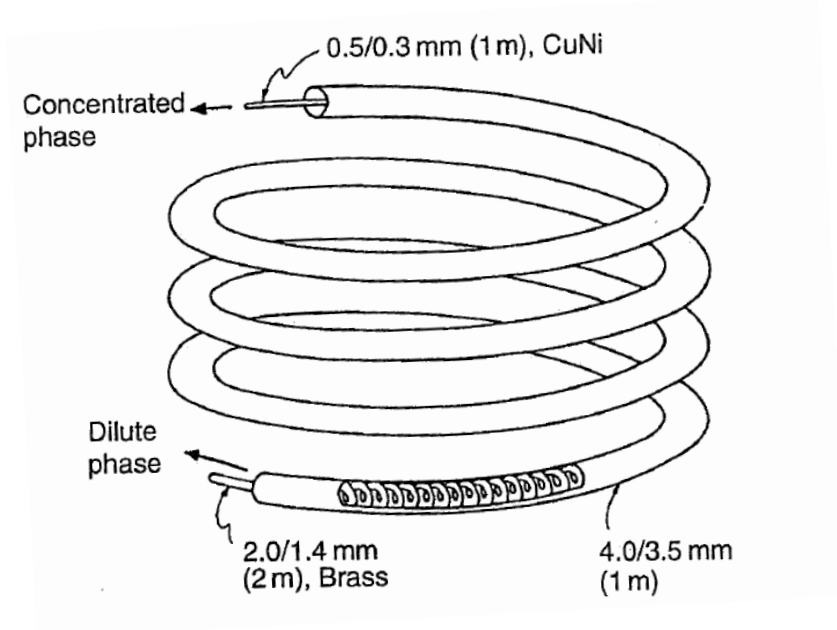

Heat exchanger design below 50 mK

- Designs using continuous heat exchangers only can reach ~30 mK.
- For lower temperatures or very high flow rates, larger surface area heat exchangers are needed to overcome the increasing Kapitza resistance.
- Simple form is a sintered metal block to give large surface area, with a machined channel to reduce flow impedance (and hence viscous heating).
- To minimize axial heat flow, several discrete heat exchangers are connected in series – “step” heat exchangers at progressively lower temperature.

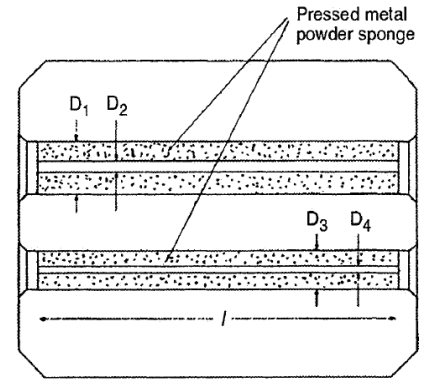

General discrete heat exchanger layout (from Pobell, 2007)

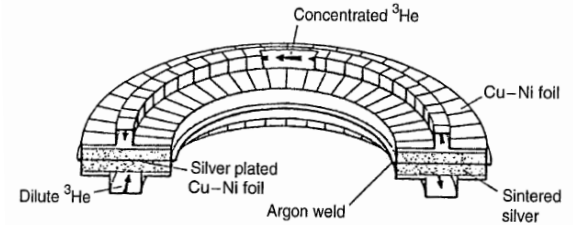

General Common design in commercial fridges similar to that shown above (from Pobell (2007), adapted from Frossati (1992)).

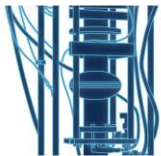

Mixing chamber

- The mixing chamber is relatively simple. Major requirement is for a large contact area between the helium phases and the metal.
- This is typically achieved through sintered structures, such as the silver sponge example shown right.
- In this design, the diameter of the mixing chamber is approximately 100 mm, while the sponges have a surface area of tens of square meters.

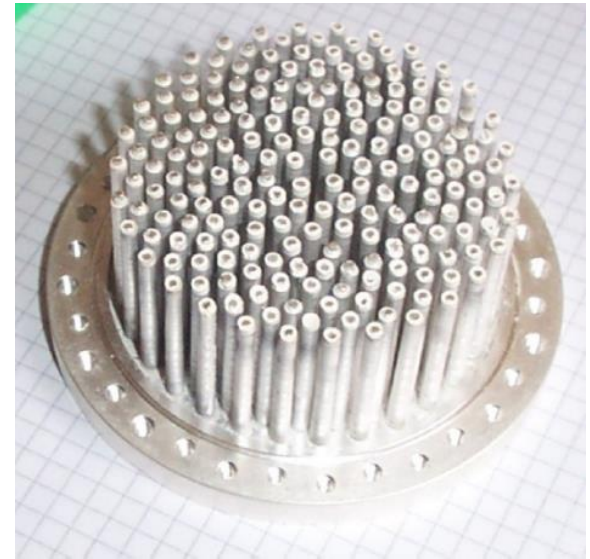

Mixing chamber construction example from Uhlig (2015)

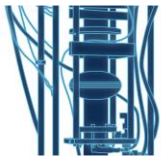

Room temperature components – Pumps

- Choice of pumps depend on circulation rate and desired base temperature.
- Usually consist of a primary pump (scroll or roots), sometimes combined with a booster pump.
- Still pumping may be supplemented with one or more turbomolecular pumps for higher-performance systems.
- For efficient condensation, it is often necessary to use a compressor to increase the inlet pressure (and decrease the outlet pressure of the primary pump).
- Important that pumps are sealed for helium use and do not contaminate the process line.

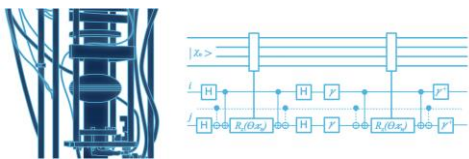

Room temperature components – Filtering and sealing

- Majority of the gas handling at room temperature will be subatmospheric, so will tend to suck in air that could contaminate the process line.
 - Fridges generally include cold filters with Pt or other metal sinters internally
 - Many will also include an external activated charcoal trap in liquid nitrogen
 - For very long duration runs, an LHe or 4-K trap can also be used.
- Choice of flanges and seals is important. Metal seals generally much better than rubber, but harder to work with.
 - Be wary of parts of the system that will see internal pressure. If using rubber O-rings, it may be necessary to add overpressure rings.

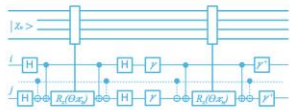
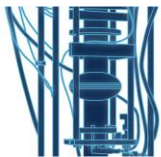

History and Development of the Dilution Refrigerator

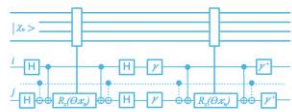
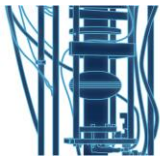

Early development

- The idea of using $^3\text{He}/^4\text{He}$ mixtures as a refrigeration method was first proposed by London in 1951, and further developed in 1962 by London, Clarke and Mendoza.
- First demonstrations:
 - Das, de Bruyn & Taconis (1965) reached 220 mK
 - Hall, Ford and Thompson (1966) reached 80 mK
 - Neganov, Borisov & Liburg (1966) reach 25 mK
- The refrigerator of Hall *et al.* is shown on the right.

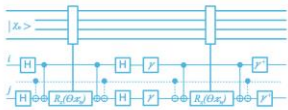
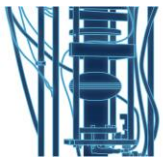
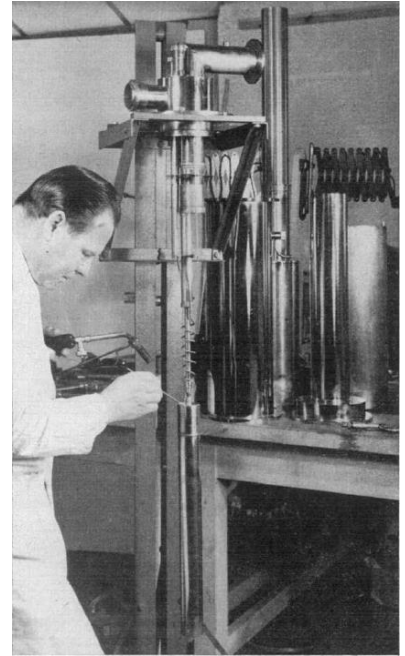

Early commercialization

- The first commercial refrigerators were built in the mid-1960s by Oxford instruments, first in collaboration with Heinz London, and later based on Hall's design licensed from the UK Atomic Energy Authority.

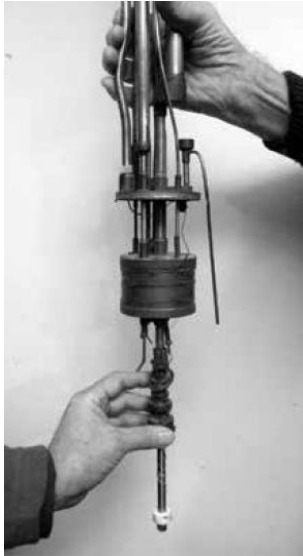

(Left) Early commercial refrigerator insert

(Right) Commercial refrigerator with copper heat exchangers, c.1975

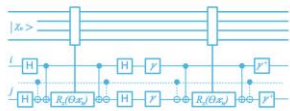
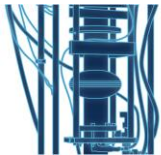

Eliminating the liquid helium

- The primary feature that distinguishes modern refrigerators from the older style is the use of mechanical precoolers in place of the liquid helium bath.
- This was made possible by an earlier innovation, the Joule-Thomson Heat Exchanger.
- Described independently by Kraus at ZTB and by de Waele at Eindhoven in 1977, this device eliminates the 1-K Pot in a wet dilution refrigerator by using a long counterflow exchanger cool the Helium-3 stream with gas pumped from the still, followed by an expansion valve.
 - This stage cools and partially liquifies the Helium-3, with the remaining liquification taken care of by the still.

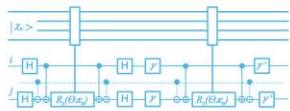
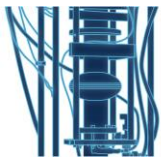

Eliminating the liquid helium (continued)

- Removing the 1-K Pot served three important purposes:
 - The pumped pot can be a significant source of vibration in sensitive experiments
 - The pumped pot can dominate the Helium consumption of a system
 - The pot is prone to blockage, making it a common source of fridge failure
- Note that it would not be ideal to just cool and liquify the Helium-3 by running the gas directly to the still since the enthalpy of the gas is larger than that of the gas leaving the still at $\sim 1\text{K}$.
 - This has been demonstrated, but only for very low flow rate fridges with efficient precooling, so not a very practical approach.

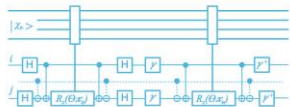

Eliminating the liquid helium (continued)

- With improvements in mechanical cryocoolers in the late 1980s, it was a natural step to couple one to a dilution refrigerator.
- First example described by Pari in 1990, followed by the pioneering development work of Uhlig starting in 1993.
- **These fridges (an example of Uhlig's cryostat shown right)** initially used 10 K Gifford-McMahon coolers.
- Important to note that 4-K class cryocoolers were not available until 1999-2000.

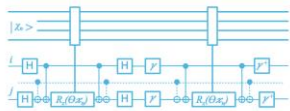
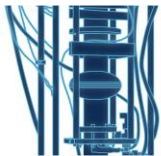
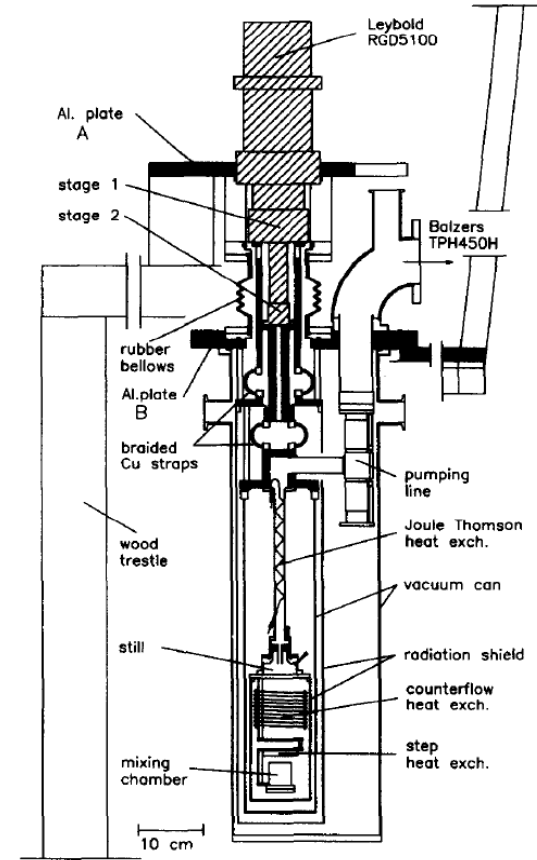

“Dry” vs “Wet” refrigerators

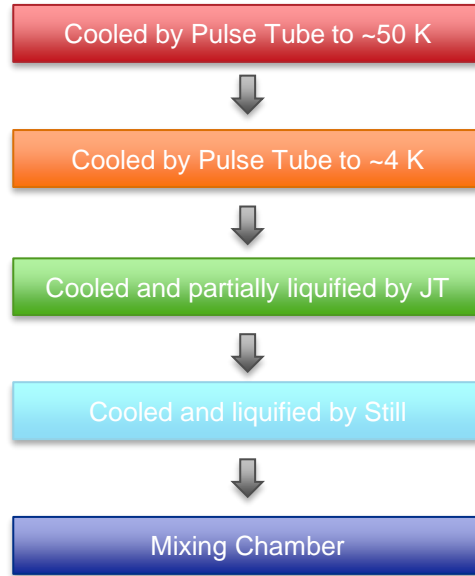

“Dry” Process

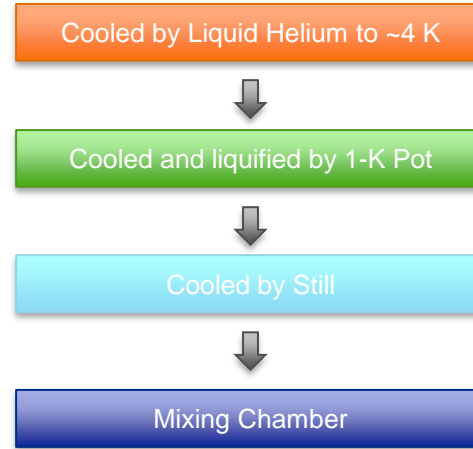

“Wet” Process

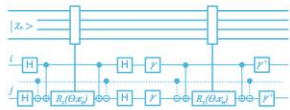
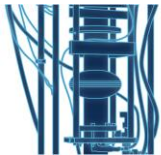

Early commercial dry fridges

- Early examples of commercial cryogen-free fridges came from Leiden Cryogenics and Air Liquide in the early 2000s
- The Leiden refrigerator, built for the SCUBA-2 astronomical camera (right) is still operational at 14000 feet at the James Clerk Maxwell Telescope in Hawaii.
- Limitations of these early designs were often poor heat exchange at 4 K on the second stage of the pulse tube cooler.

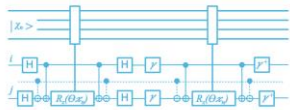
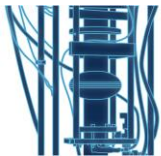

Improvements to the pre-cooler design

- An interesting property of the pulse tube cooler was measured in the early 2000s in that excess cooling capacity on the regenerator between the two stages exists.
- Some heat can be dissipated on the regenerator with little impact on the 4 K cooling performance.
- Adding a coil to the regenerator provides a useful additional heat sink for the inflowing ^3He , reducing the cooling load at the 4-K stage.

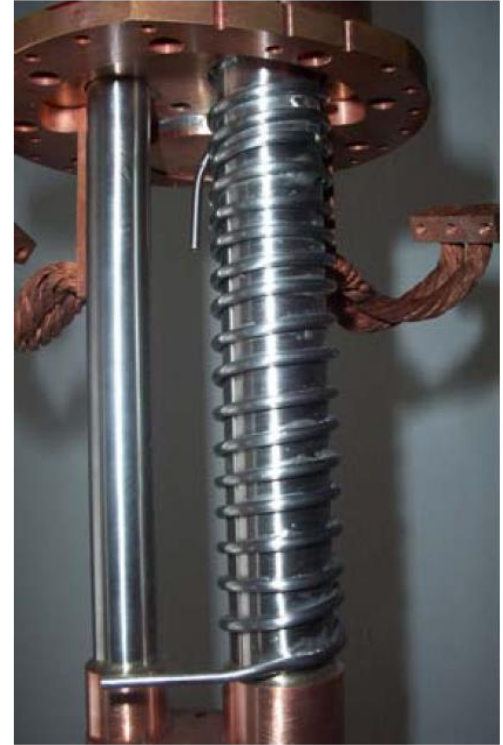

Additional heat exchanger
(Uhlig, personal communication)

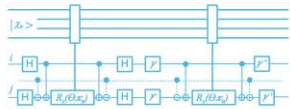
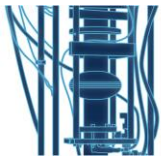

Modern Dilution Refrigerator Design and Operation

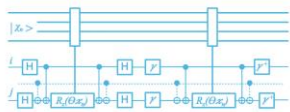
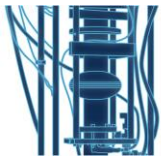

Modern refrigerator layout

Image: Oxford Instruments

2 stage pulse tube cooler

Additional heat exchanger



Additional heat exchanger (Uhlig, personal communication)

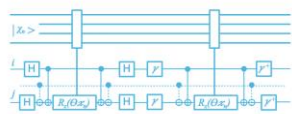
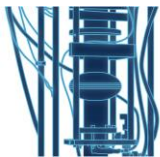
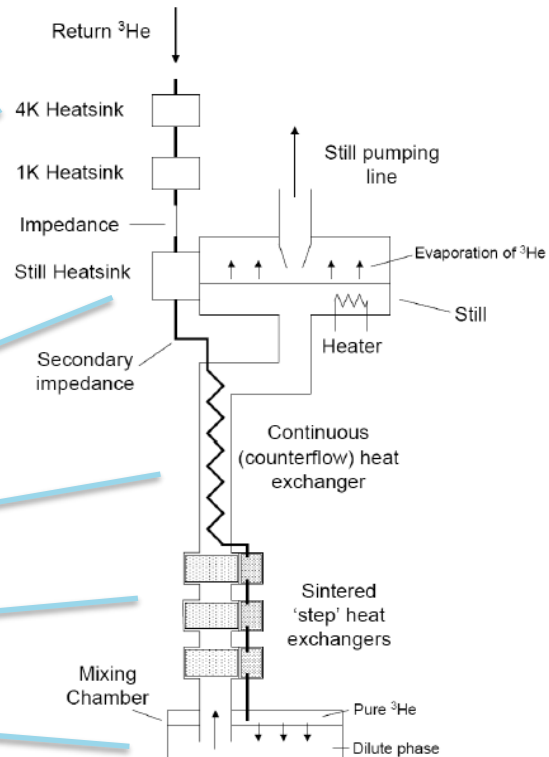
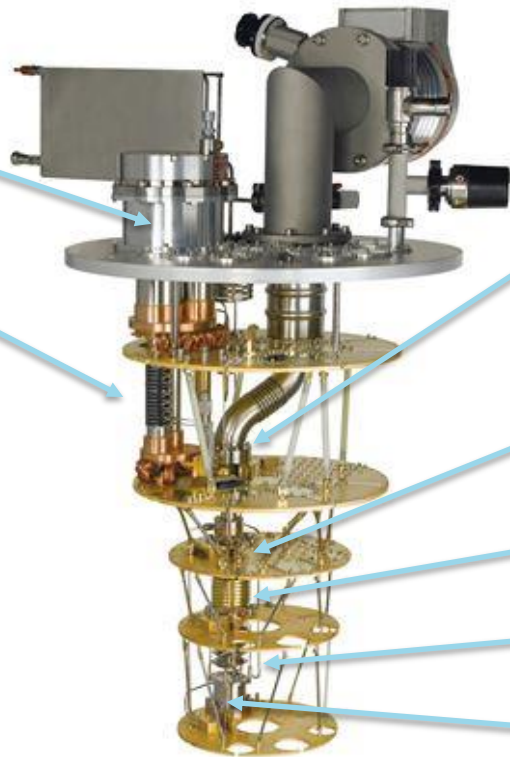

Modern refrigerator layout – temperature stages and dilution unit

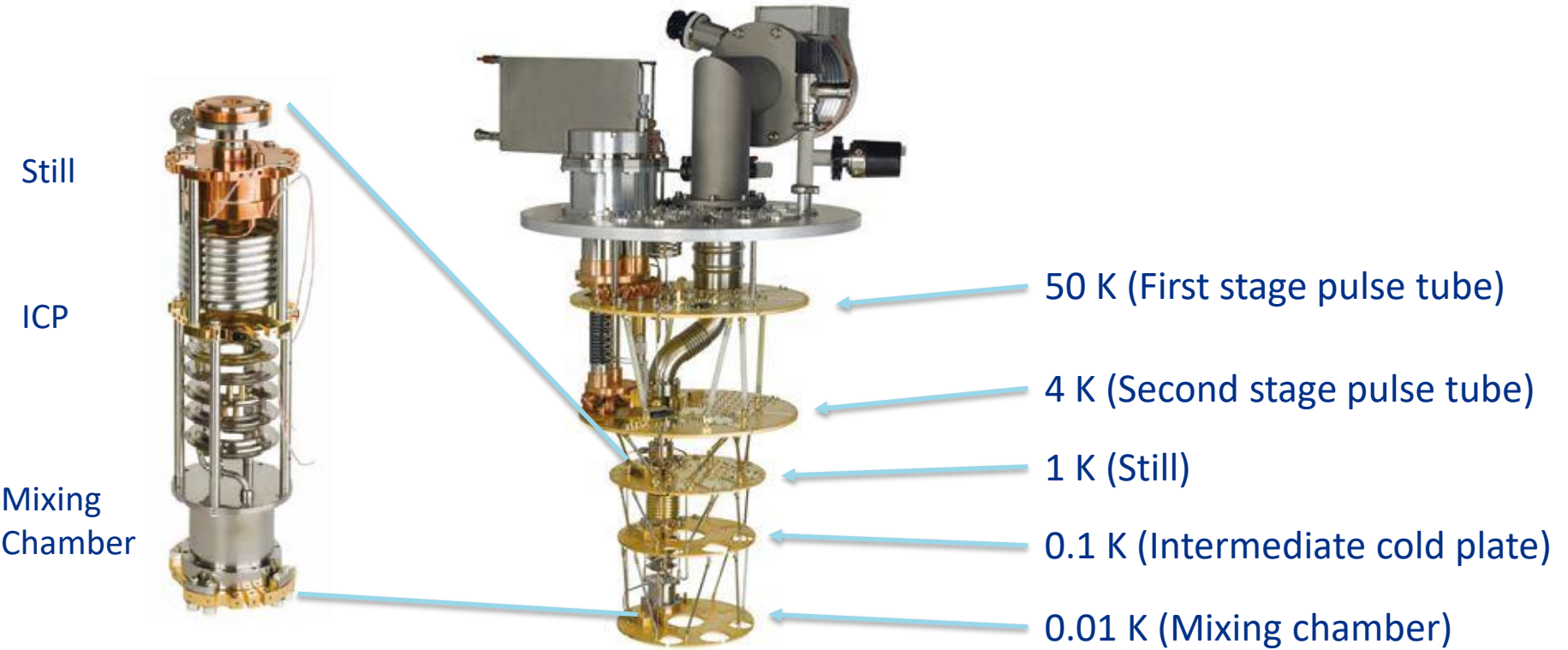

Images: Oxford Instruments

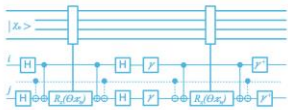
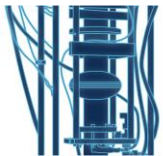

Commercial fridge examples

Image: Oxford Instruments



Small fridges
 Mixing chamber diameter ~150mm
 Minimum temperature ~25 mK

Image: Oxford Instruments



Standard fridges
 Mixing chamber diameter ~300mm
 Minimum temperature ~10 mK

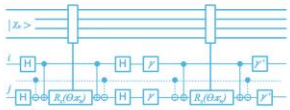
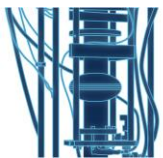

Commercial fridge examples (continued)

Image: BlueFors



Large frame fridges
 Mixing chamber diameter ~500mm
 Minimum temperature ~10 mK

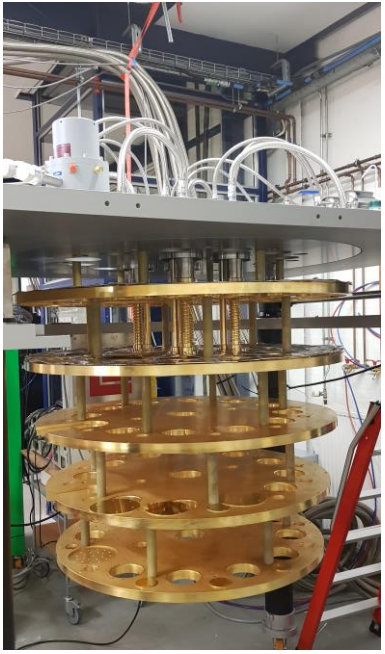
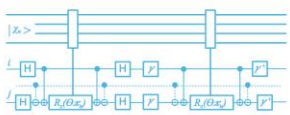
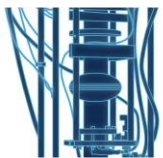
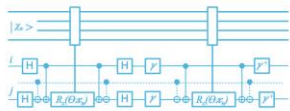
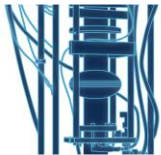

Image: Leiden Cryogenics

"XXL" fridges
 Mixing chamber diameter ~1000mm
 Minimum temperature ~10 mK



Materials at Low Temperature



Thermal conductivity

- Thermal conductivity includes contributions from electrons (in metals) and phonons (in metals and insulators).
- As temperature decreases, **the phonons will freeze out**, strongly reducing the conductivity in insulators and leaving the **electrons as the dominant conduction mechanism in metals**.
- In superconducting metals, conduction falls off below T_c since **Cooper pairs have poor energy transport properties**.

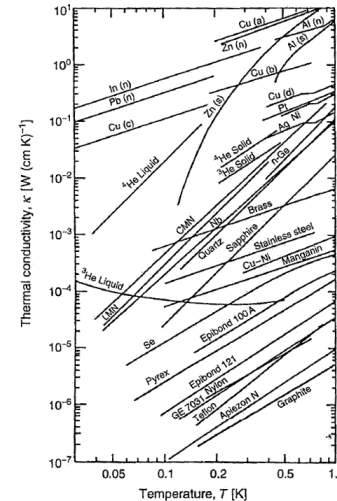
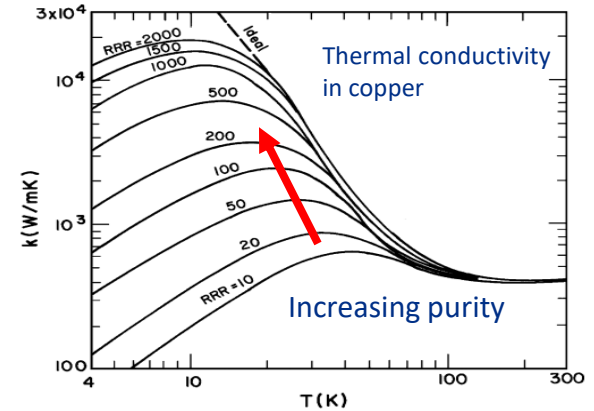

Pobell (2007)

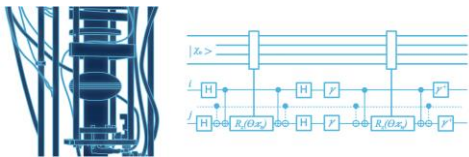

Thermal isolation

- Assuming a notional support with dimensions chosen to give the same stiffness/fundamental frequency (so we are comparing like-with-like), we can compare the conducted heat for different materials.

Material	Conducted Heat (1 K to 0.1 K)
G-10 CR	11.5 μ W
Stainless Steel 304	12.0 μ W
Carbon Fiber Reinforced Polymer	3.5 μ W
Titanium 15-3-3-3	2.8 μ W

- CFRP is an extremely amorphous material, so lots of scattering
- Ti 15-3-3-3 is superconducting, with a $T_c \sim 3$ K

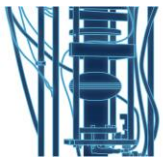

Contact conductance

- At interfaces, physical contact exists over microscopic asperities.
- Area available for heat transfer is a tiny fraction of the macroscopic contact area. This can be maximized by using very low surface roughness (i.e. polished) surfaces.
- Many of the “tricks” to improve conductance at high temperature don’t work well below 1 K.

Fig. 1.1 Heat flow through a joint

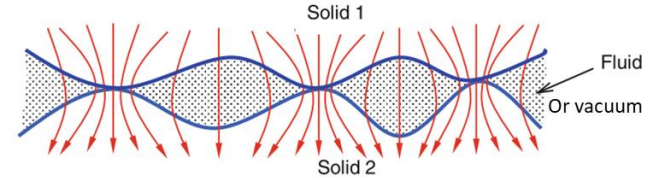
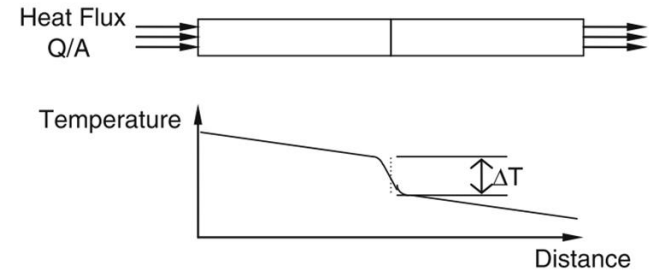
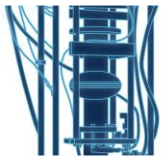

Fig. 1.2 Temperature drop at an interface



From Thermal Contact Conductance (2014) C V Madhusudhana



Permanent joining techniques

- Less common to join components permanently than with a demountable joint, but still worth considering in some circumstances.
- Permanent joining techniques include:
 - Soldering/brazing (basically the same process at different temperatures), using a filler (solder or braze alloy). Be wary of superconductors in fillers.
 - Welding, which melts the base metal.
- Electron-beam welding is extremely effective at low temperatures, especially for copper. Can also be used to join dissimilar metals. E-Beam welding does not use a filler rod, unlike GTAW.

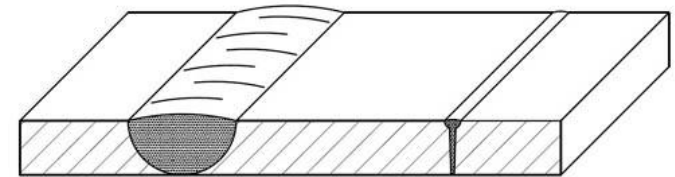
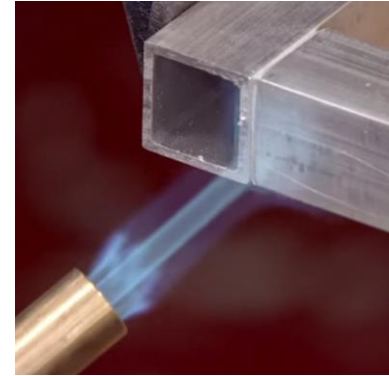

CONVENTIONAL WELD

ELECTRON BEAM WELD

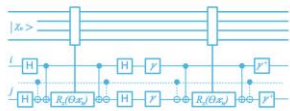
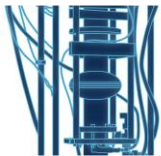

Improving contact conductance

- For a fixed joint pressure, thermal resistance at a joint can be lowered using an interposer.
- Need to be wary that interposers such as N grease or indium are less effective below 1 K (and can degrade the joint) but can be useful in very low-pressure joints.
- Gold (silver, or Pt) plating is very effective.
- Surface treatments that prevent oxidation are also effective.

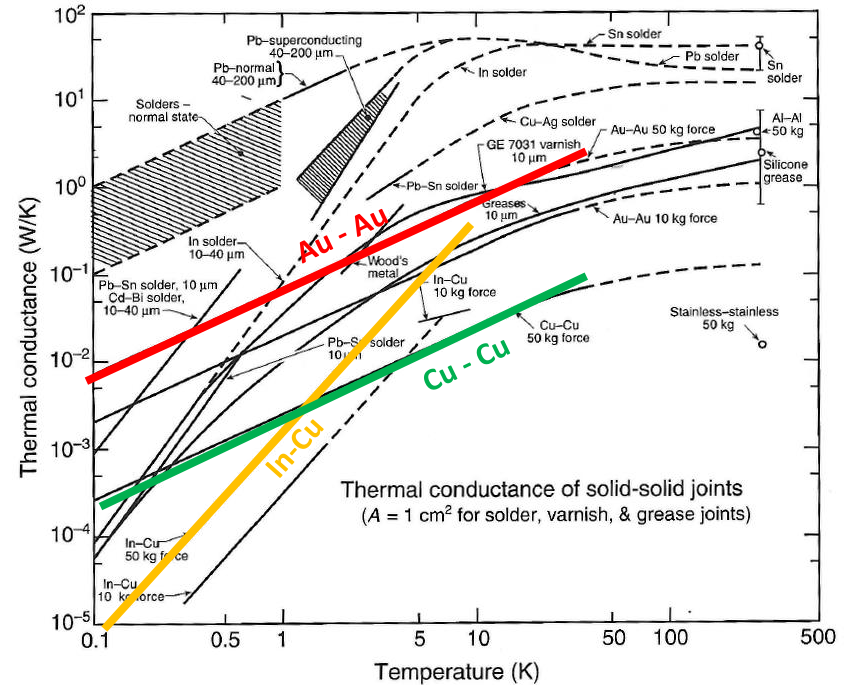

Adapted from Eiken (2006)

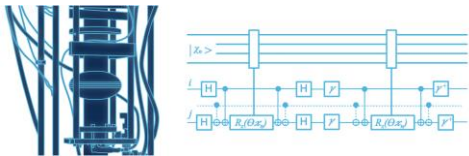

Summary, Concluding Remarks, References

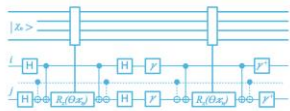
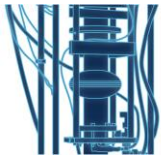

Summary

- We have reviewed:
 - The physics of Helium-3/Helium-4 mixtures and the dilution process
 - Practical aspects of constructing a refrigerator and the design of key components
 - The history of development of modern, cryogen-free refrigerators
 - Current state-of-the-art
 - Materials and engineering approaches for low temperature experiments
- This of course was a very quick tour through a complex set of topics – if anyone has detailed questions, please feel free to talk during the break, or you can contact me at mhollist@fnal.gov

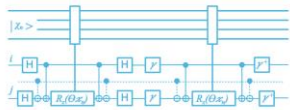
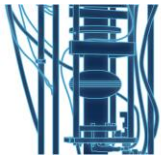

Useful references

- **“Matter and Methods at Low Temperatures”**, Frank Pobell – Very good general textbook for low temperature physics
- **“Experimental Principles and Methods Below 1K”**, O.V. Lounasmaa – Good description of the dilution refrigeration process, although was published in 1974 so is out of date on the technology
- **“Experimental Techniques for Low-Temperature Measurements”**, Jack Ekin – Not so much about the cooling techniques themselves, but has a wealth of cryogenic reference data

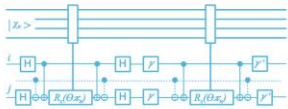
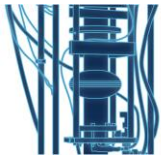

Acknowledgement

This manuscript has been authored by Fermi Research Alliance, LLC under Contract No. DE-AC02-07CH11359 with the U.S. Department of Energy, Office of Science, Office of High Energy Physics.

