

# SLAC Project-X RF Development

November 14<sup>th</sup> 2012

Rosa Ciprian, Heinz Schwartz



U.S. DEPARTMENT OF  
**ENERGY**

Office of  
Science



# RF high power sources 325MHz & 650MHz

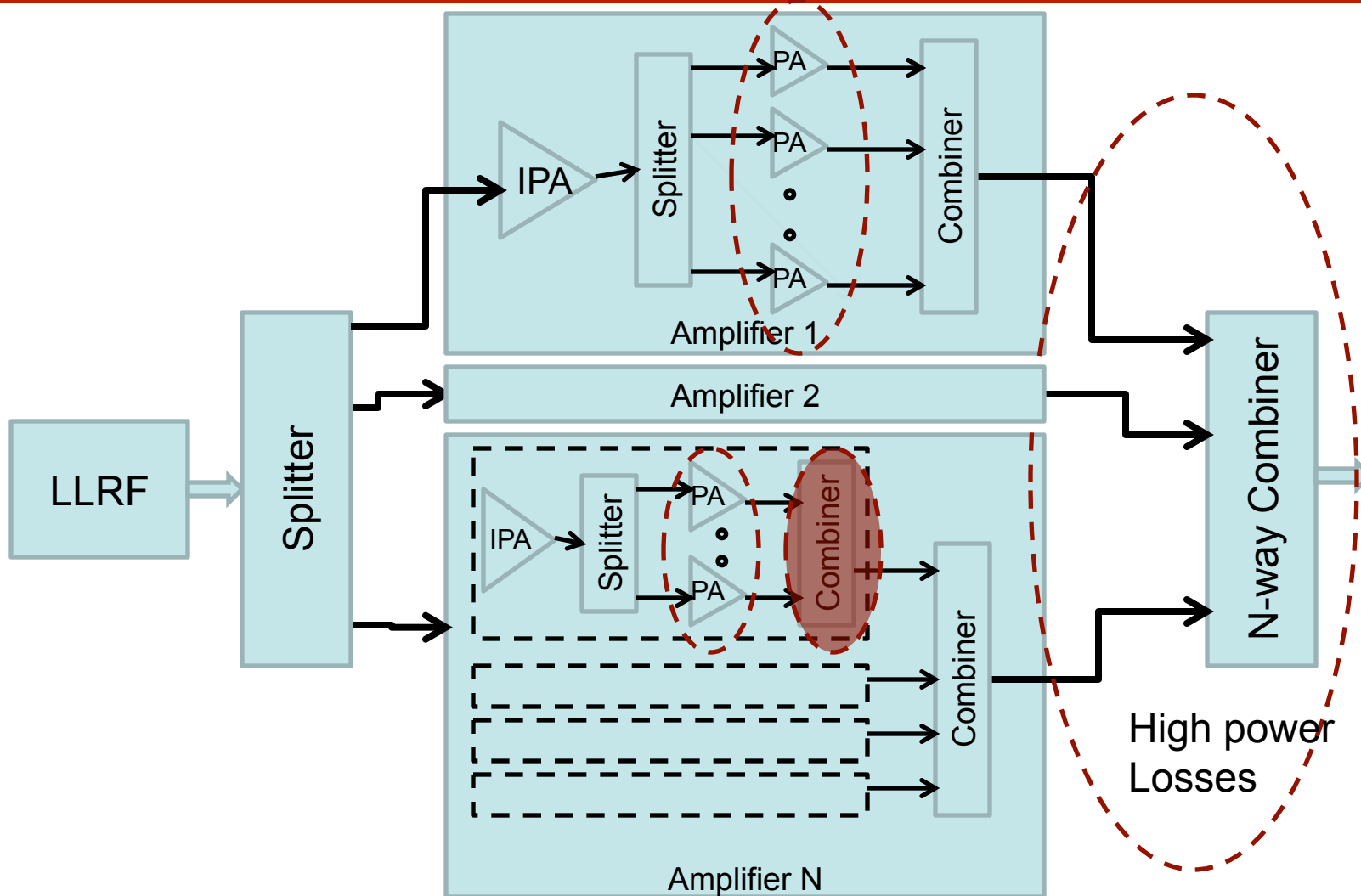

# OUTLINE

---

- Baseline amplifier progress
- 2.5 kW vendor-built evaluation
- Options for combining networks
- Controls, LLRF

# 2.5kW Amplifier Eval

---

- Nautel delivered amplifier by end of September.
- Migrated to 8 amplifiers/module (redundancy)
- Transistors evaluation of efficiency > **70%**
- Efficiency varies with operating point
- Overall dimension 3U 19" rack: ~ 19" x 5.2" x 30"
- **MEASURED AC-RF efficiency @ SLAC:  
~60% @ 2.5kW**
- At 25% of max power ~800W AC-RF efficiency 48%

# 2.5kW Amplifier Eval – cont.

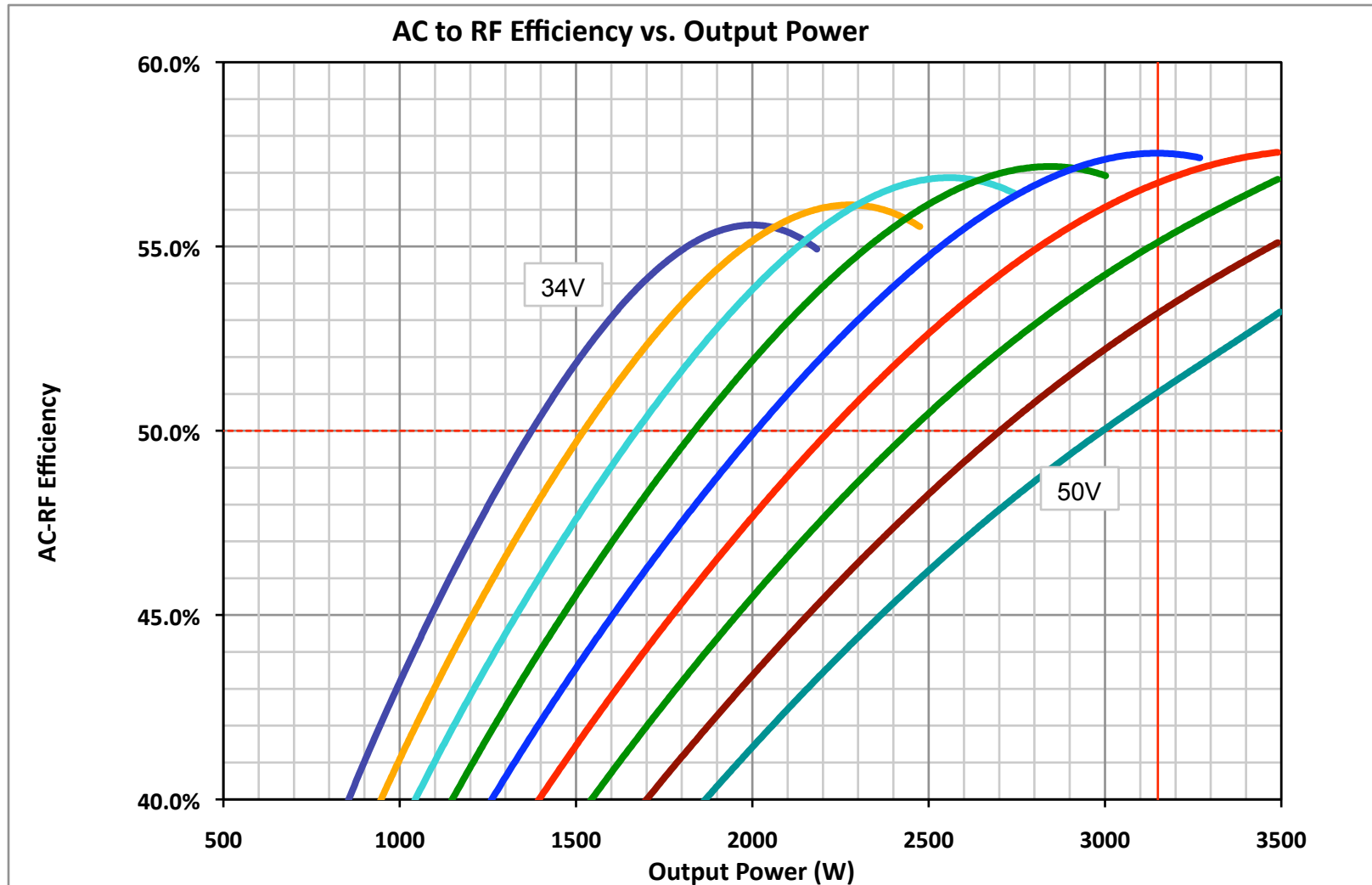

# 2.5kW Amplifier Eval – cont.

---

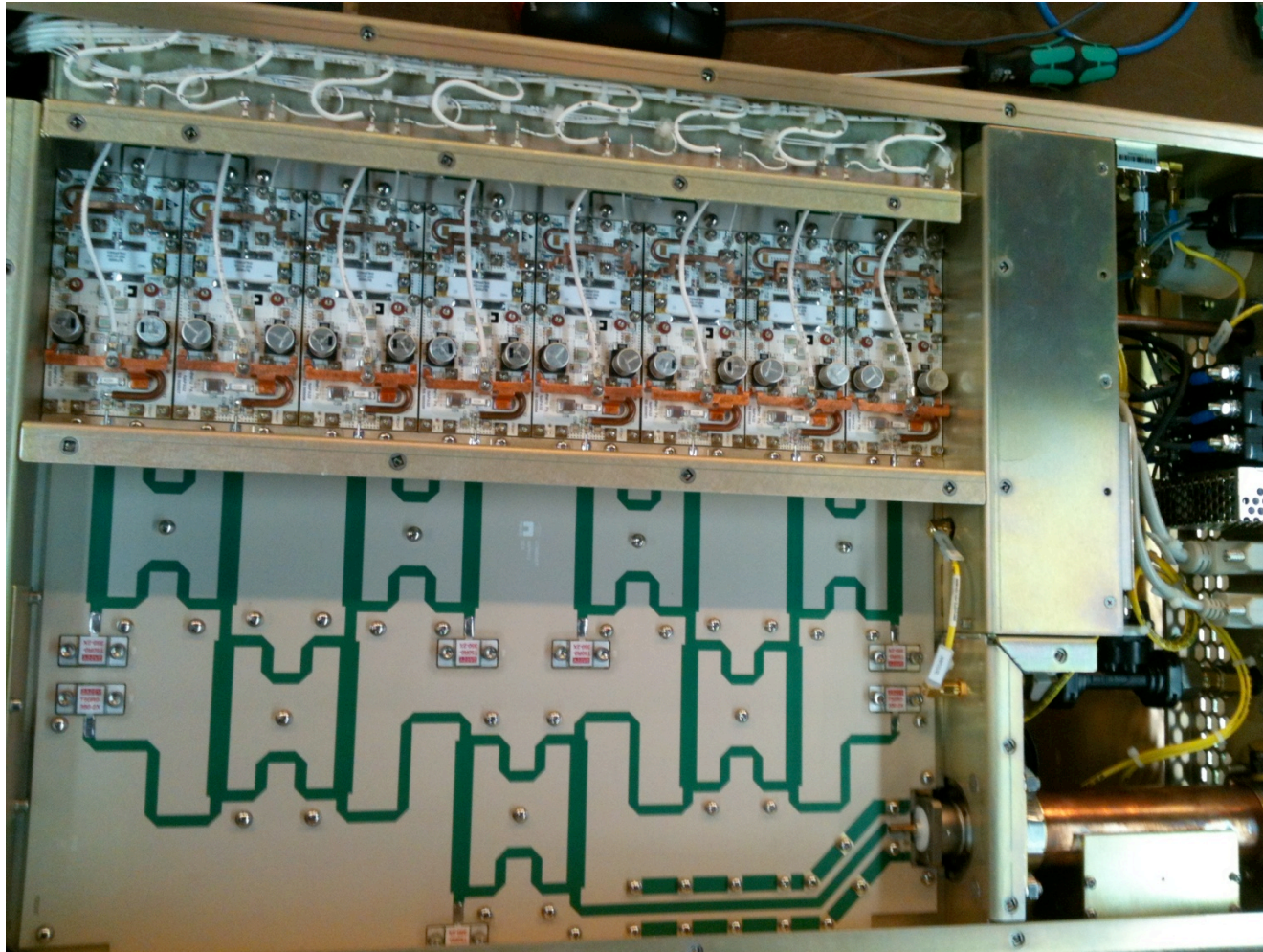

# 2.5kW Amplifier Eval – cont.



# 2.5kW Amplifier Eval – cont.

---

Others:

- 2.5 GPM cooling water @  $\sim 30^{\circ}\text{C}$
- Best efficiency at  $\sim 800\text{W}$  is with  $V_d=21\text{V}$  and  $-1.5\text{dBm}$  input
- Best efficiency at  $\sim 2.5\text{kW}$ ,  $V_d= 38\text{V}$  and  $0\text{dBm}$
- Max power  $\sim 3.5\text{kW}$  efficiency  $\sim 58\%$  with  $V_d = 44\text{V}$
- Verified some local and remote controls and protection
- $\sim 80\text{ lb}$



# Combiners - losses/max pwr

TYPE	Att (dB/ 100ft)	Average Pwr (kW)	Bend radius (in)
Microstrip RT6035HTC 125mils	8.64	2.7 (*)	
Microstrip RT6035HTC 250mils	6	4 (*)	
7/16" HELIAX	3	2	
1 5/8" HCA158-50 air dielectric	0.5	7.3	7
1 5/8" LCF158-50 CELLFLEX foam	0.54	6.3	8
3" HCA-300 HELIFLEX air dielectric	0.338	14.6	11
5" HJ9-50 HELIAX air dielectric	0.222	30	
5" HCA495-50 HELIFLEX air dielec	0.23	31.8	20
6 1/8" HCA618-50 HELIFLEX air	0.157	65.6	39
WR1150 11.5"X5.75"	0.09	200 (**)	
WR1500 15"x7.5"	0.0553	500 (**)	

# 30kW Combiners Failure Mode

	8-way	10-way	12-way	16-way
Output power 1 fail (%)	77%	81%	84%	88%
Power/mod for 30kW (kW)	3.75	3	2.5	1.875
Power/mod for 1 fail (kW)	4.9	3.7	2.975	2.14
Output pwr 2 fail (%)	56%	64%	69%	77%

# 30kW Combiners

---

- 2kW modules using AB amps just need two levels of hybrid combiners within.
- Gysel combiner 16x1 (2kW => 30kW) with coax inputs offers low loss. Projected design from Nautel would not fit in a 19" rack, but very close
- PS and controls separately from amp modules.
- Independent modular power lines to each subgroup (4x4 or 2x8) for redundancy and ease of implementation

# 30kW Efficiency assessment

---

Choice of 100W, 250W and 500W affects overall efficiency and dimensions:

- 100W class F amplifiers with drain efficiency in the 80% and assuming 500W modules in the 70% can get 58% overall efficiency. Modules can be arranged in 2 x 19" racks.
- 250W amplifiers with drain efficiency in the 60% range and assuming 50% at the 1.9kW module, can get to 47% overall efficiency. Modules could possibly fit in a single 19" rack.
- 500W amplifiers (derated to 320W) with drain efficiency in the 70% range and assuming 57% at the 2.5kW module ~3U each, can get to 53% overall efficiency. Modules will fit in a single 19" rack.
- The same 500W amplifiers arranged into a 2kW module can get up to 58% overall efficiency with a 16x1 Gysel combiner. Modules will be less than 2U each.

# Controls

---

- No-beam load is about 25% of the nominal load.
- Process for maximum efficiency (class AB amplifiers):
  - Reduced drain voltage during no-beam mode
  - Ramp up drain voltage to prepare for nominal load. Efficiency is not optimized during this time
  - LLRF to bring up output power
  - This process can be implemented on the LLRF side (lookup table?), with digital control for PS and analog signal for phase and amplitude.
- For a class F amplifier, output power is directly controlled from the LLRF side, no major difference in efficiency throughout. Response time (BW) depends on power supply.

---

# Additional Slides

# Amplifiers - commercial

---

- MRFE6VP5600H: 600W CW **60%** efficiency
- BLF888B: (NXP/Nautel)
  - Up to 600W
  - 500W @ 48V with **71%** drain efficiency and 22dB gain.
  - Phase change
    - less than 0.1deg over 1 hour
    - ~0.45deg with 3°C change at baseplate
    - ~5deg with a 7V drain voltage change
    - ~2.5deg with a 10% load change.
  - Harmonics: More than 50dBc up to 3.9GHz.