

Gas System

Igor Liubarsky

Instituto de Física Corpuscular-Valencia

Aim of Gas System

- ✦ Primary

- ✦ Maintain Gas purity necessary for charge drift

- ✦ Cold Getter

- ✦ Hot Getter

- ✦ Secondary

- ✦ Provide security measures against loss of gas

- ✦ Sensing

- ✦ Recovery

Primary Loop

Gladys

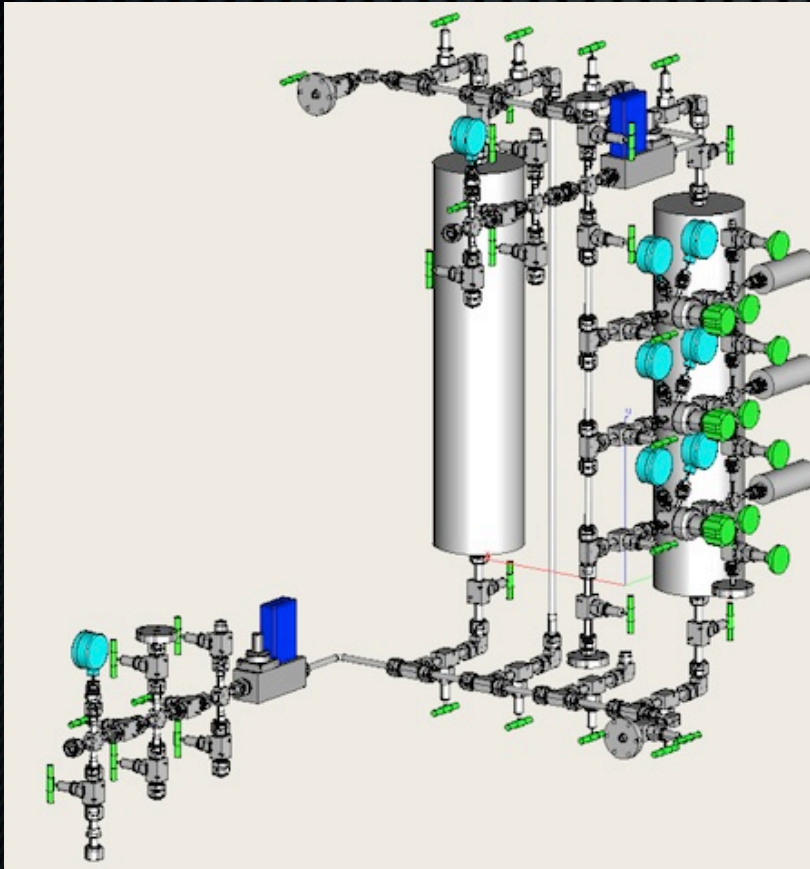

Primary Loop

Gladys

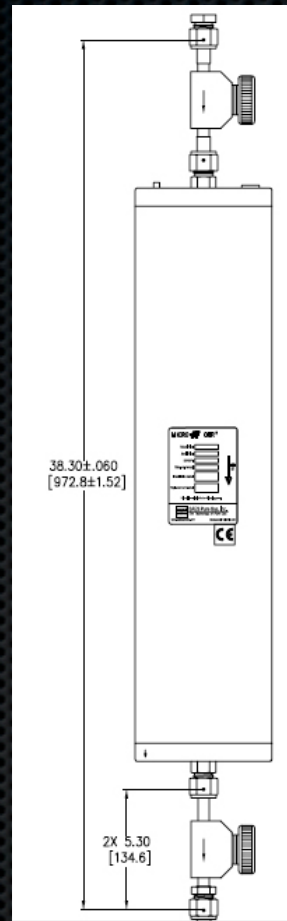

MC4500



MT50

Secure Re-circulation Compressor

Triple Diaphragm

Stainless-Bronze-Stainless

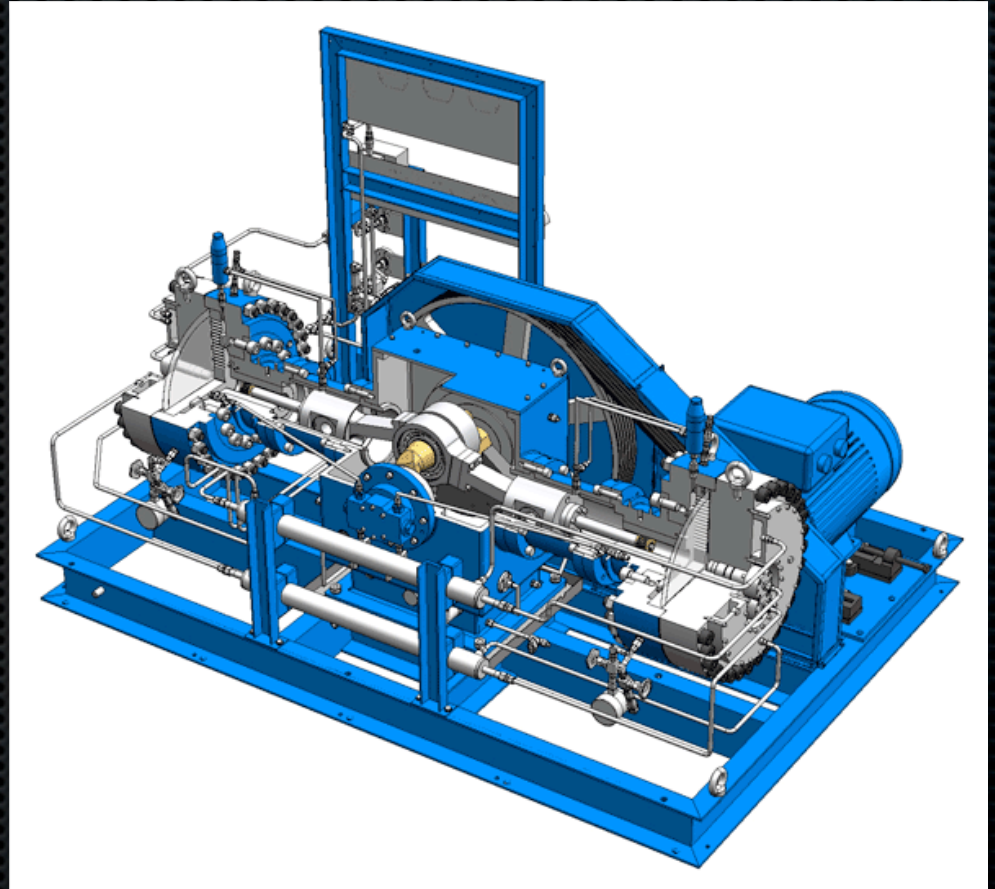

<http://www.sera-web.com>

Leak Sensing

Multi-Channel RGA
software to
recognise leaks



Leak Recovery

Xe Cold Trap

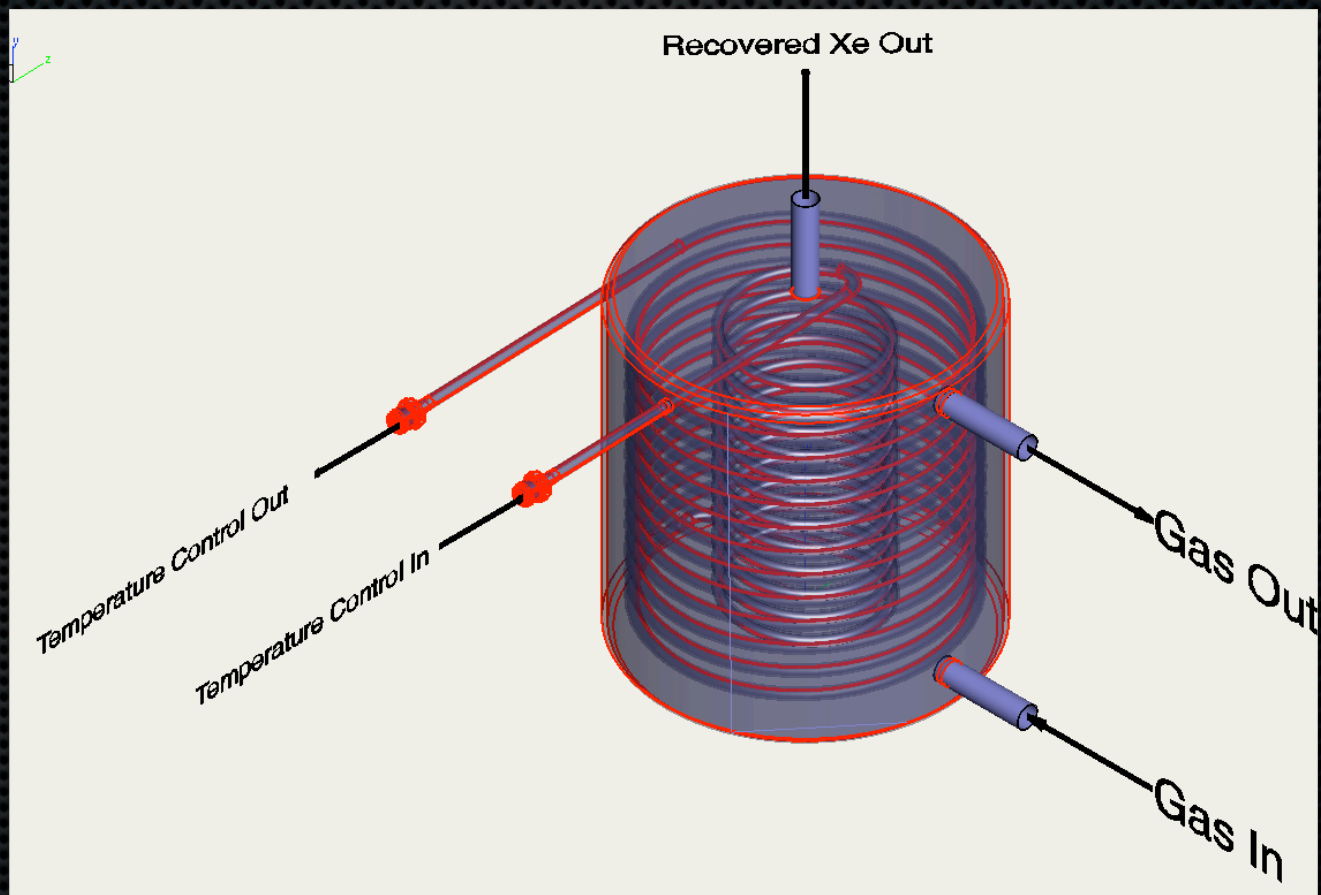

Leak Recovery

Expansion Tanks



ZEPLIN

Gas System

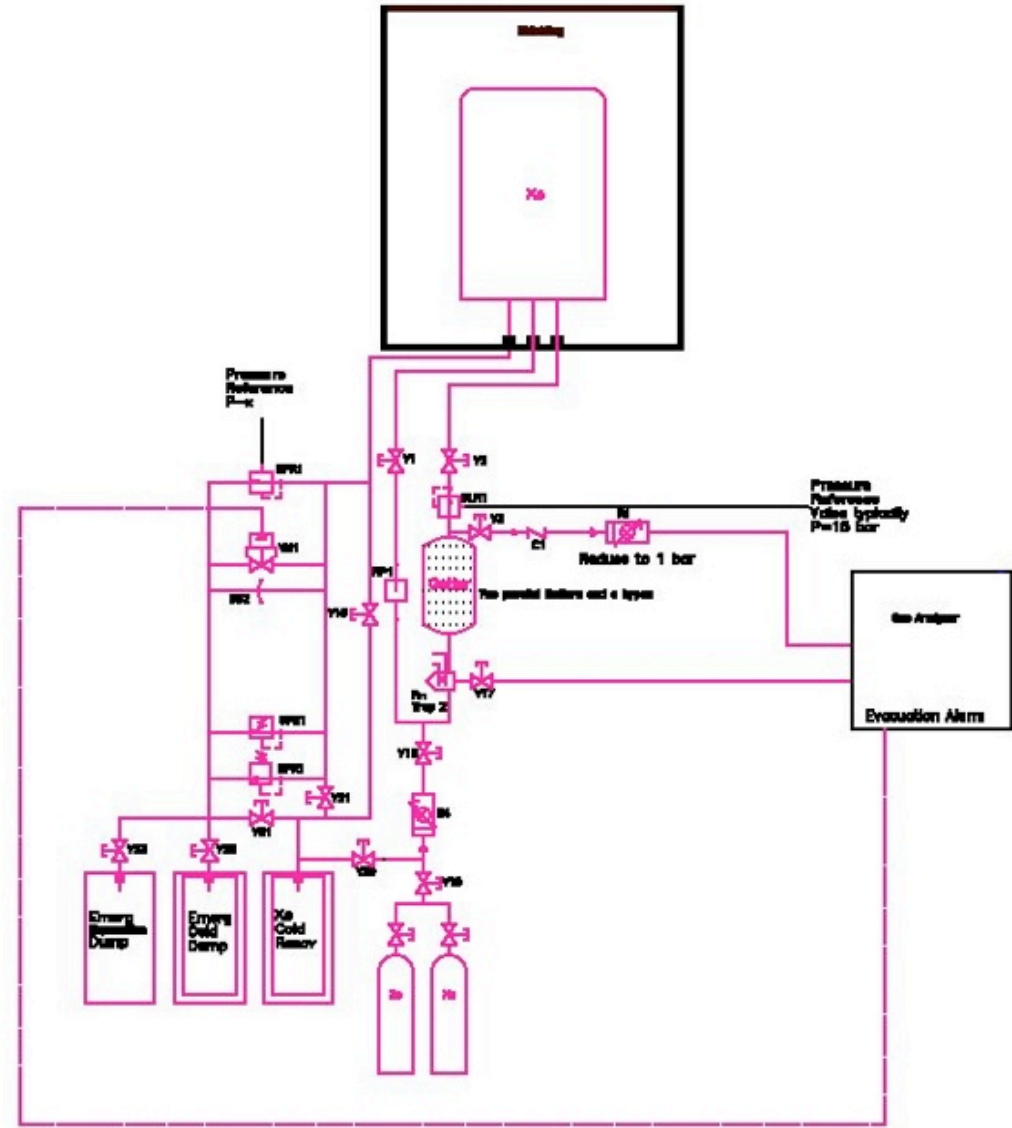
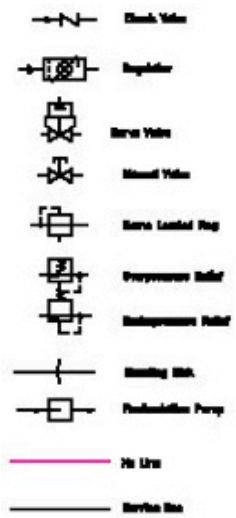

Gas System

Normal Operations

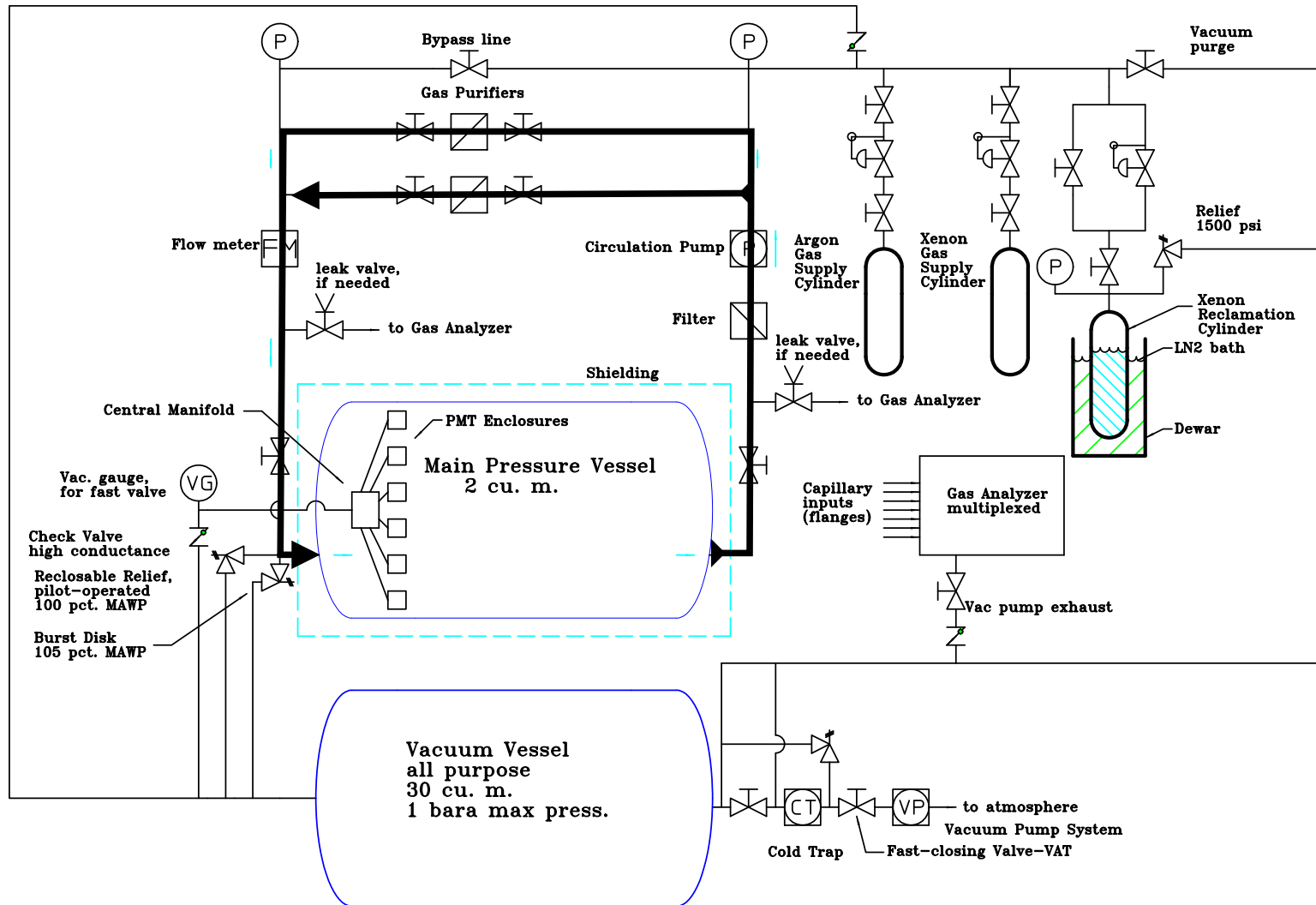

Gas System

Normal Evacuation

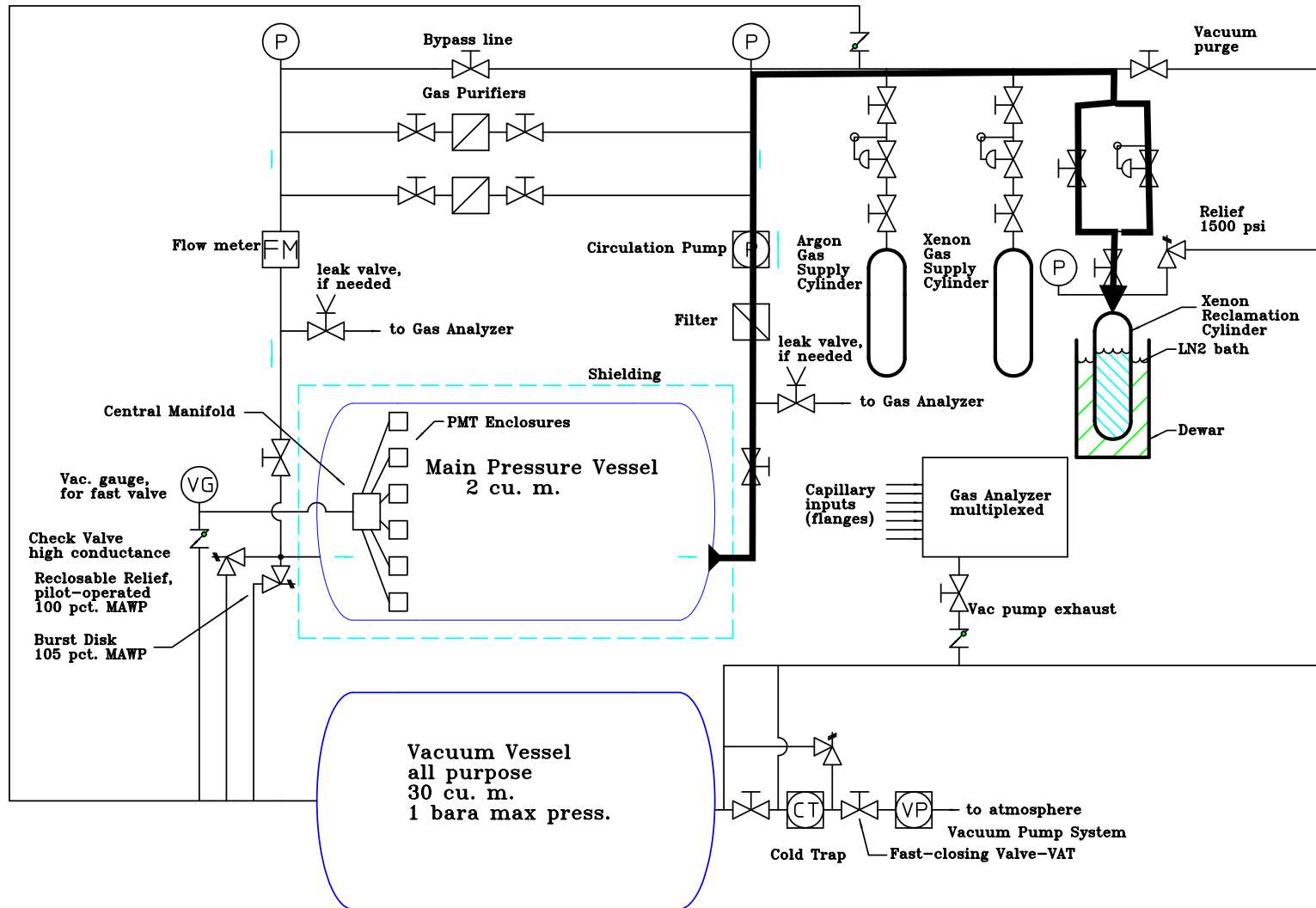

Gas System

Emergency Evacuation

