

Hadronic Molecule Effective Field Theory for T_{cc}^+

Thomas Mehen
Duke University

BEACH 2024

Charleston, SC, 6/3/2024

Discovered 7/2021: T_{cc}^+ doubly charm tetraquark

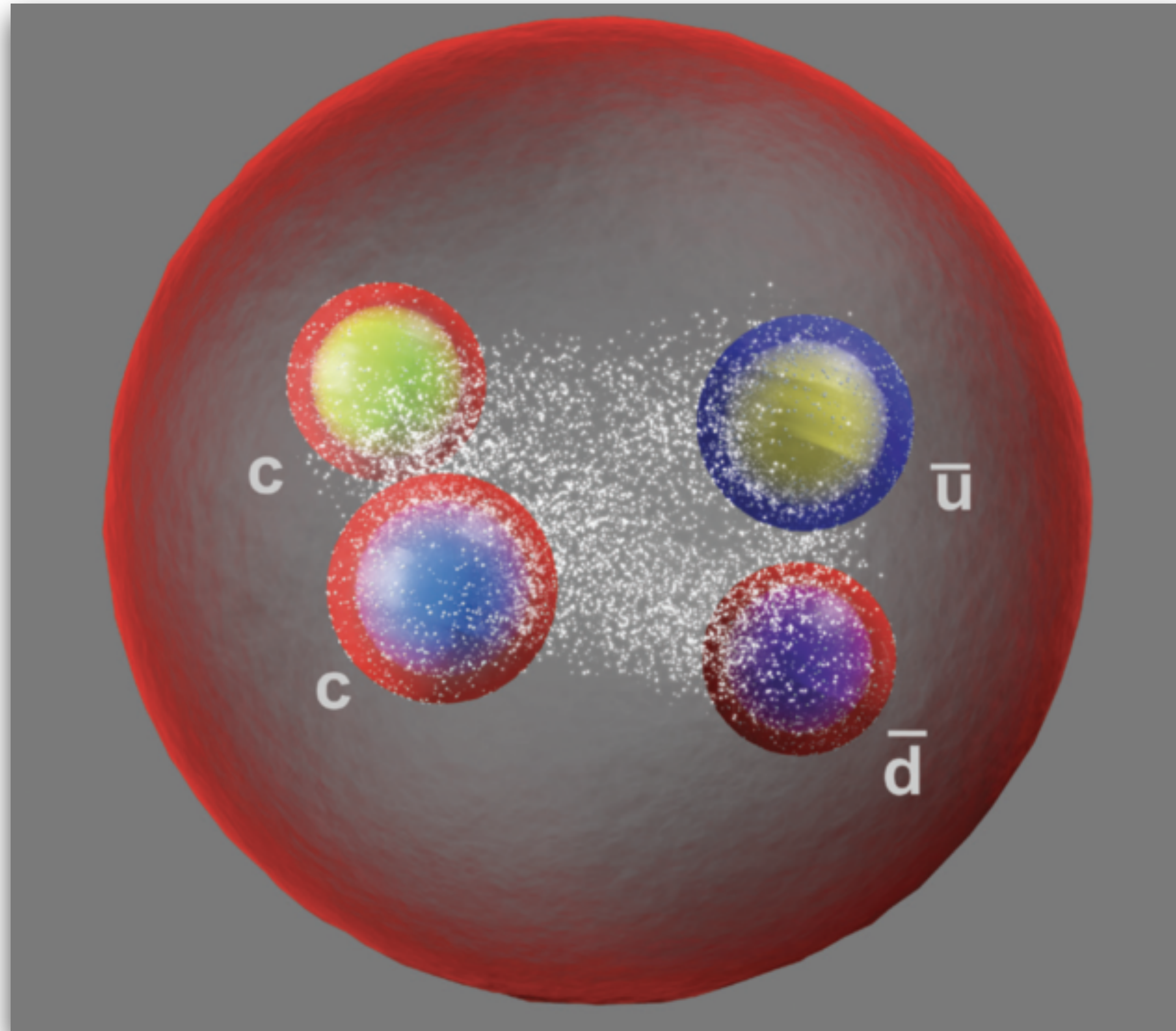

R. Aaij *et. al.* (LHCb), Nature Phys. 18 (2022) 7, 751-754, arXiv 2109.01038 [hep-ex]. (1)

R. Aaij *et. al.* (LHCb), Nature Commun. 13 (2022) 1, 3351, arXiv 2109.01056 [hep-ex]. (2)

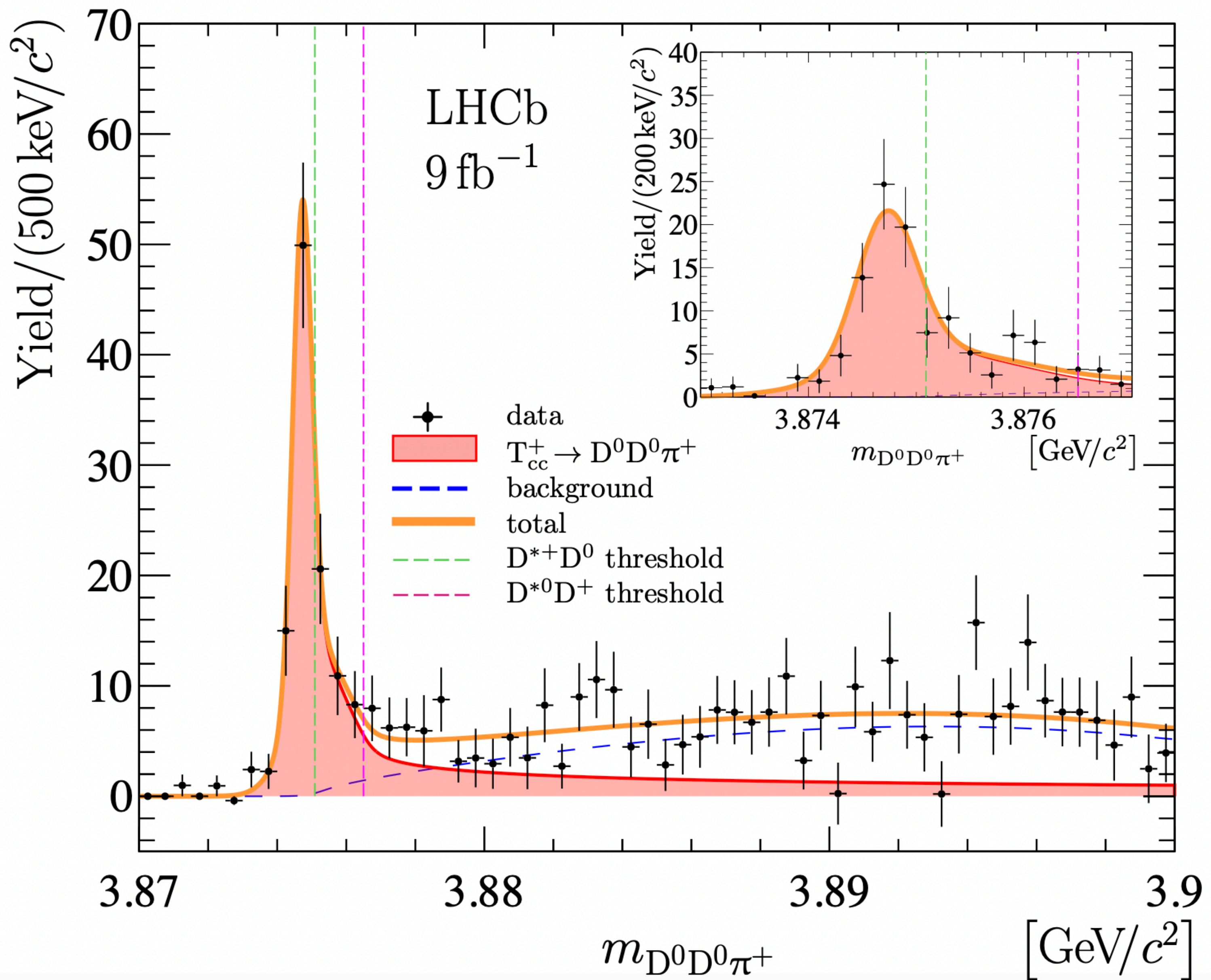

$$\delta m_{pole} = -360 \pm 40_{-0}^{+4} \text{ keV},$$

$$\Gamma_{pole} = 48 \pm 2_{-14}^{+0} \text{ keV}. \quad (2)$$

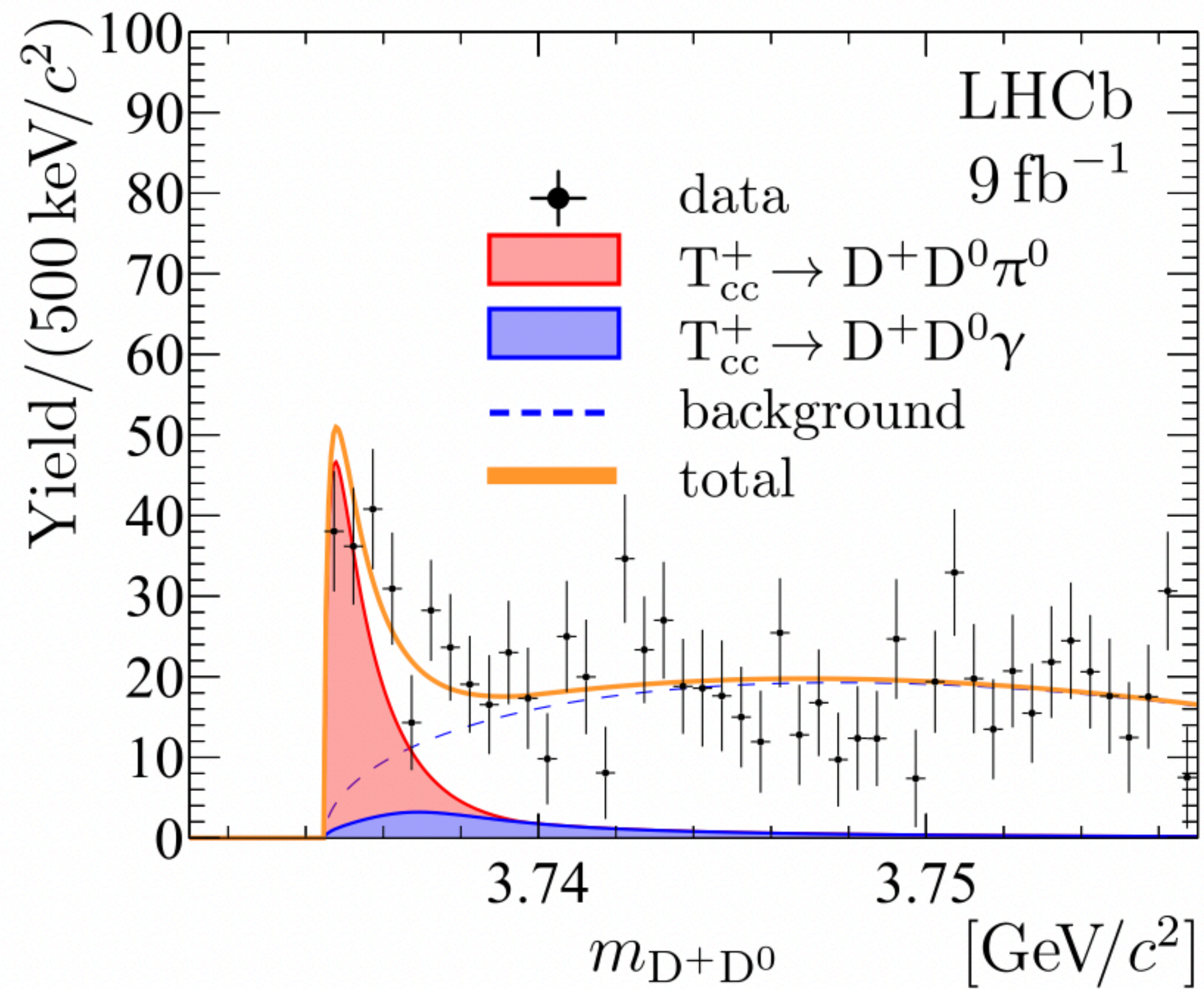
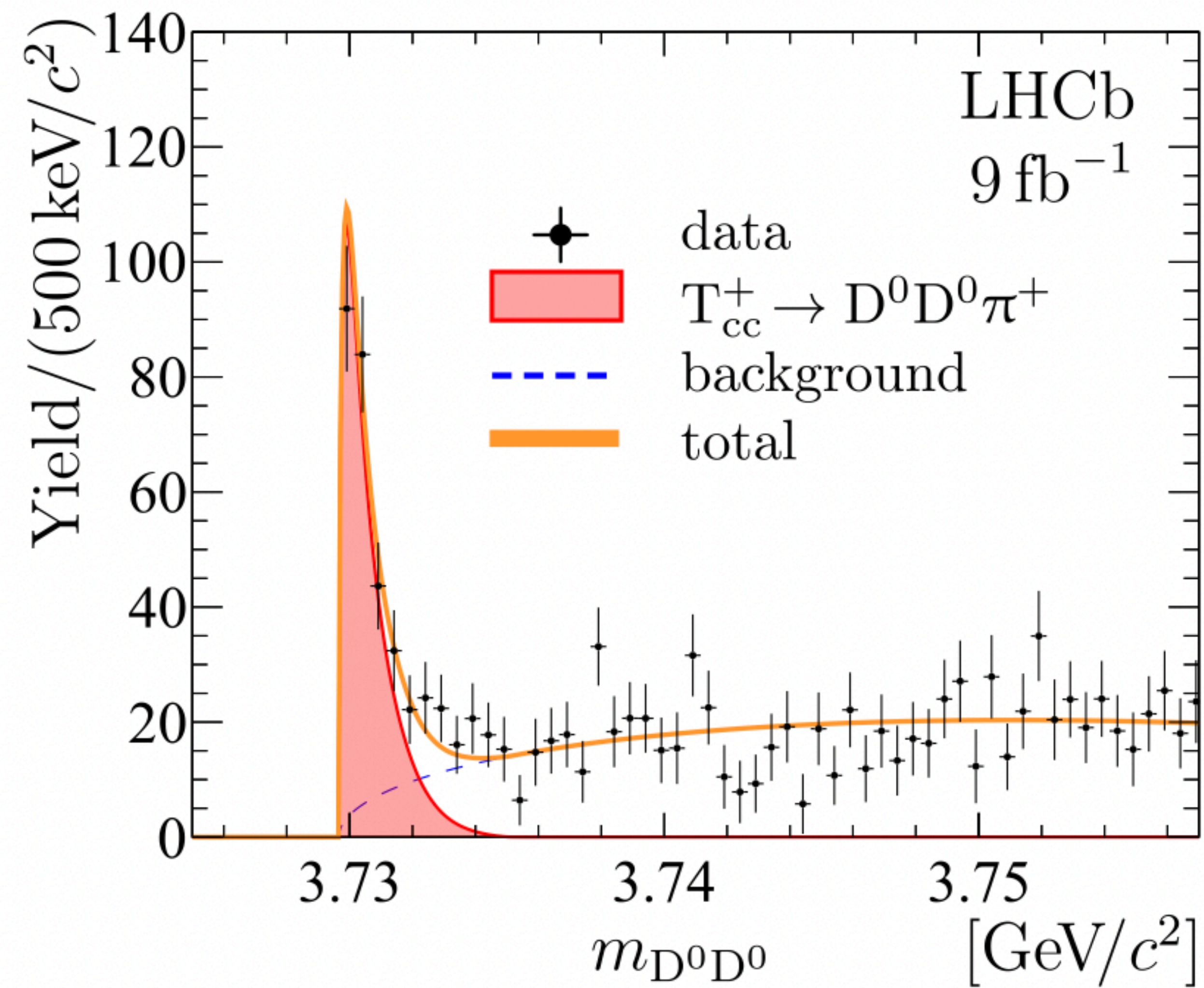

T_{cc}^+ is quite similar to $X(3872)$

Decays: $X(3872) \rightarrow J/\psi \pi^+ \pi^-$ $X(3872) \rightarrow J/\psi \pi^+ \pi^- \pi^0$
 $\rightarrow D^0 \bar{D}^0 \pi^0$ $\rightarrow J/\psi \gamma$ (C=1)
 $\rightarrow D^0 \bar{D}^0 \gamma$ $\rightarrow \psi(2S) \gamma$

angular distributions in $J/\psi \pi^+ \pi^-$ require

$$J^{PC} = 1^{++}$$

LHCb, PRL 110 (2013) 222001
arXiv:1302.6269 [hep-ex]

S-wave coupling to $D\bar{D}^* + \bar{D}D^*$

$$\frac{Br[X(3872) \rightarrow J/\psi \pi^+ \pi^- \pi^0]}{Br[X(3872) \rightarrow J/\psi \pi^+ \pi^-]} = 0.8 \pm 0.3$$

$X(3872)$ is mixed state
w/ $l=0$ and $l=1$?

Extremely Close to Threshold:

$$m_X = 3871.65 \pm 0.06 \text{ MeV}$$

$$m_{D^0} = 1864.84 \pm 0.05 \text{ MeV}$$

$$m_{D^{*0}} = 2006.85 \pm 0.05 \text{ MeV} \quad (\text{from PDG})$$

$$m_X - m_{D^0} - m_{D^{*0}} = -0.04 \pm 0.09 \text{ MeV}$$

Universality: $\psi_{D^0 D^{*0}} \propto \frac{e^{-r/a}}{r} \quad a \geq 9.5 \text{ fm} \quad B.E. = \frac{1}{2\mu_{DD^*} a^2}$

Long distance physics of X(3872) calculable in terms of scattering length,
known properties of D mesons - Effective Range Theory (ERT)

(M. B. Voloshin, E. Braaten, et. al.)

$$m_X - m_{D^+} - m_{D^{*-}} = -8.11 \text{ MeV} \quad \psi_{D^+ D^{*-}} \propto \frac{e^{-r/a_+}}{r} \quad a_+ = 1.6 \text{ fm}$$

Long distance physics of X(3872) dominated by $D^0 \bar{D}^{*0} + c.c.$ state for $r \geq 2 \text{ fm}$

This is true even if short-distance structure of X(3872) is, e.g., $l = 0$

Motivates low energy EFT description of X(3872) with D^0, D^{*0}, π^0 as relevant d.o.f.

Non-Relativistic Propagators

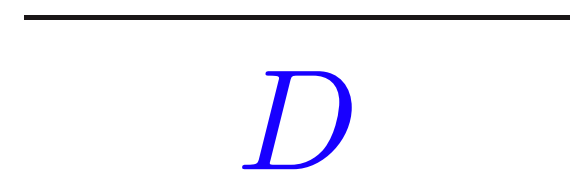

D

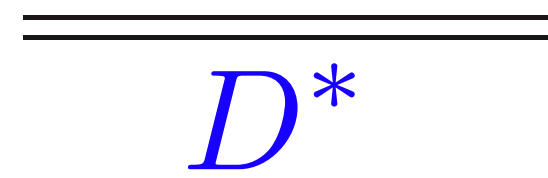

D^*

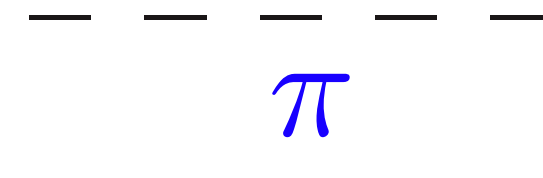

π

$$\sim \frac{1}{Q^2}$$

Contact Interactions, Pion Exchange

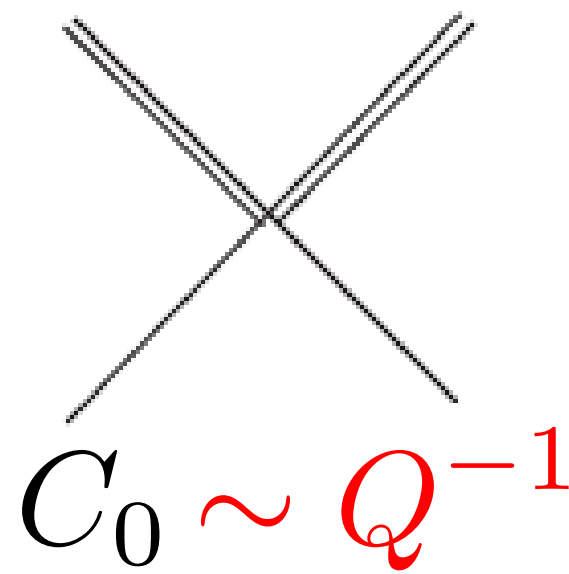

$$C_0 \sim Q^{-1}$$

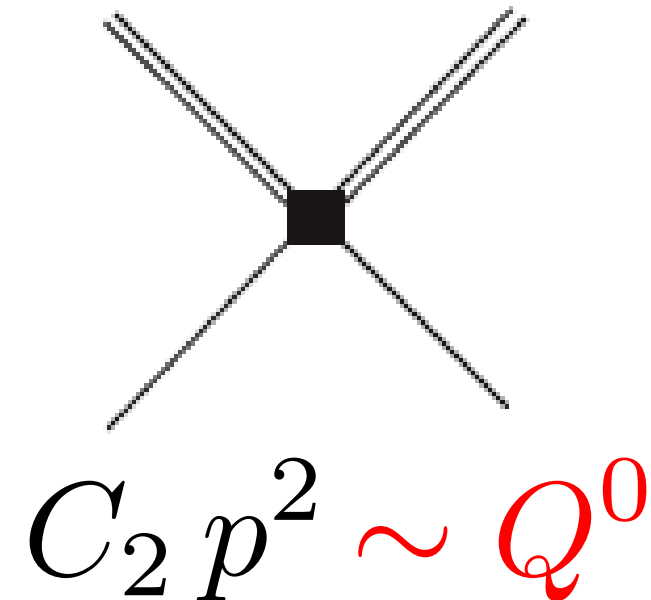

$$C_2 p^2 \sim Q^0$$

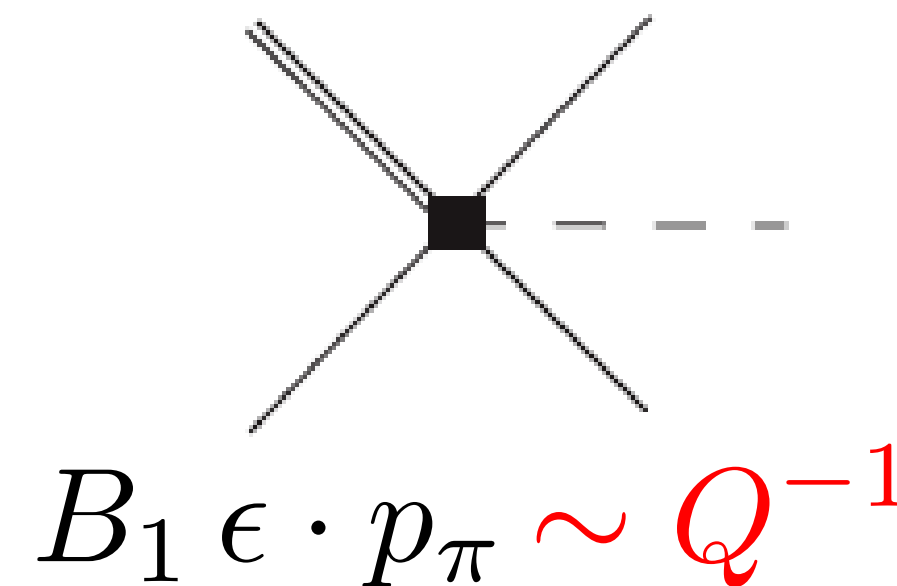

$$B_1 \epsilon \cdot p_\pi \sim Q^{-1}$$

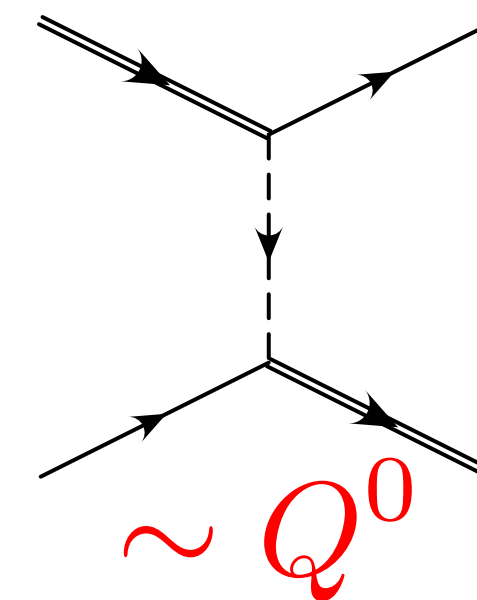

$$\sim Q^0$$

Power Counting

$$p_D \sim p_\pi \sim \mu \sim \gamma \sim Q \quad \gamma \equiv \sqrt{-2\mu_{DD^*} \text{B.E.}} \leq 34 \text{ MeV}$$

$$m_\pi \approx \Delta_H \approx 140 \text{ MeV} \quad \text{are large scales in X-EFT}$$

π^0 exchange and the X(3872)

$$\Delta \equiv m_{D^*} - m_D \approx 142 \text{ MeV}$$

$$m_{\pi^0} \approx 135 \text{ MeV}$$

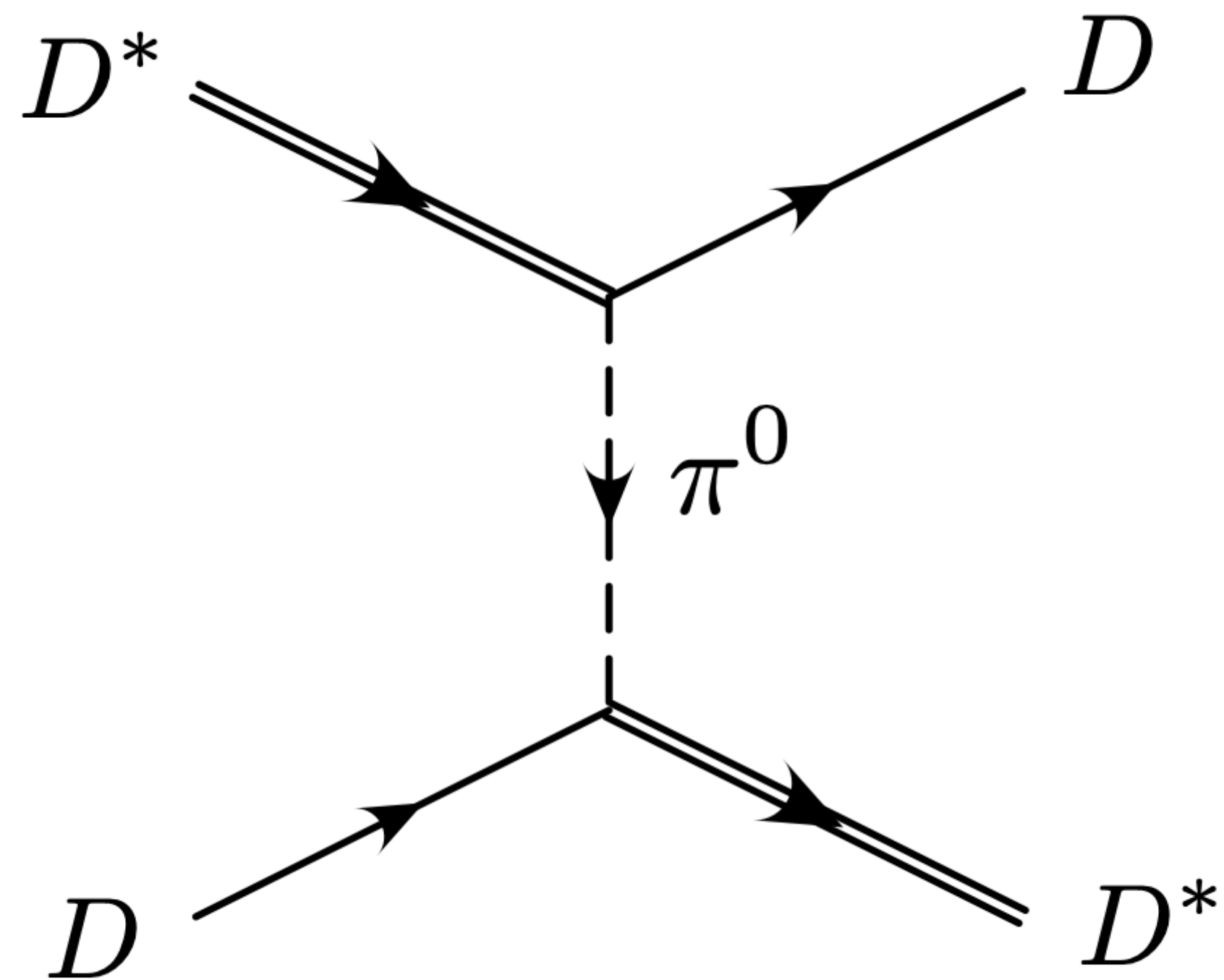

$$\propto \frac{1}{\Delta^2 - \vec{q}^2 - m_\pi^2} = \frac{1}{-\vec{q}^2 + \mu^2}$$

$$\mu^2 \equiv \Delta^2 - m_\pi^2 \approx (44 \text{ MeV})^2$$

μ - new long distance scale

(Torngqvist, Suzuki)

perturbative pions and the X(3872)

nuclear physics: pion exchange in NN scattering

$$\overline{\text{---}} \text{---} = \frac{g_A^2}{2f^2} A \left(\frac{p}{m_\pi} \right), \quad \overline{\text{---}} \text{---} \text{---} = \left(\frac{g_A^2}{2f^2} \right)^2 \frac{M m_\pi}{4\pi} B \left(\frac{p}{m_\pi} \right)$$

Expansion parameter: $\frac{g_A^2 M_N m_\pi}{8\pi f^2} \sim \frac{1}{2}$

X(3872) $g_A = 1.25 \rightarrow g \sim 0.5 - 0.7$ $m_\pi \rightarrow \mu$

$$\frac{g^2 M_D \mu}{8\pi f^2} \sim \frac{1}{20} - \frac{1}{10}$$

LO - reproduce ERT prediction for $X(3872) \rightarrow D^0 \bar{D}^0 \pi^0$

M.B.Voloshin, PLB 579: 316 (2004)

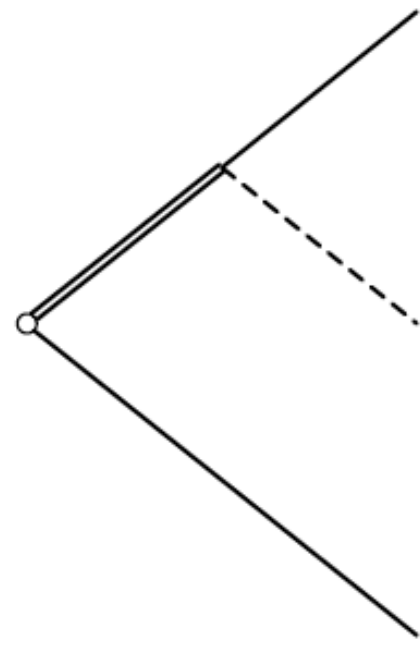

$$\frac{d\Gamma_{\text{LO}}}{dp_D^2 dp_{\bar{D}}^2} = \frac{g^2}{32\pi^3 f_\pi^2} 2\pi\gamma (\vec{p}_\pi \cdot \vec{\epsilon}_X)^2 \left[\frac{1}{p_D^2 + \gamma^2} + \frac{1}{p_{\bar{D}}^2 + \gamma^2} \right]^2$$

NLO - range corrections, non-analytic corr. from π^0 exchange

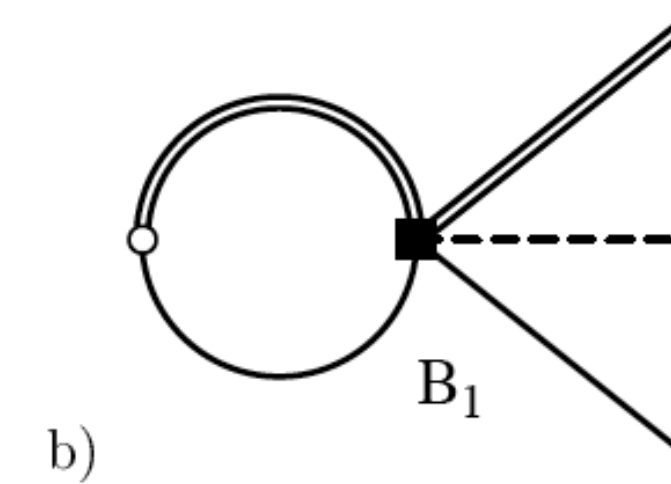
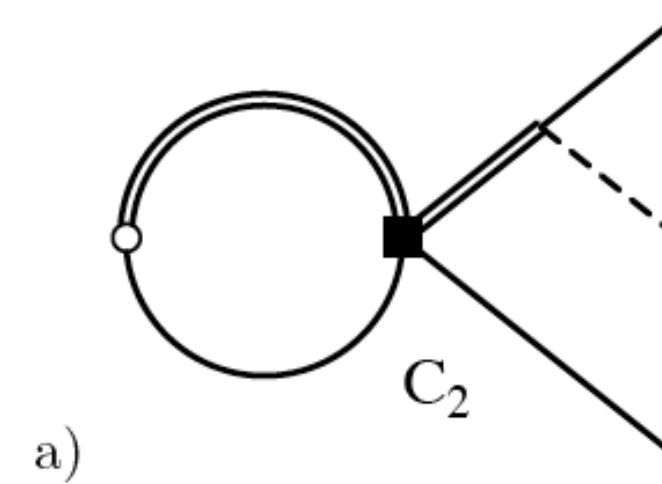
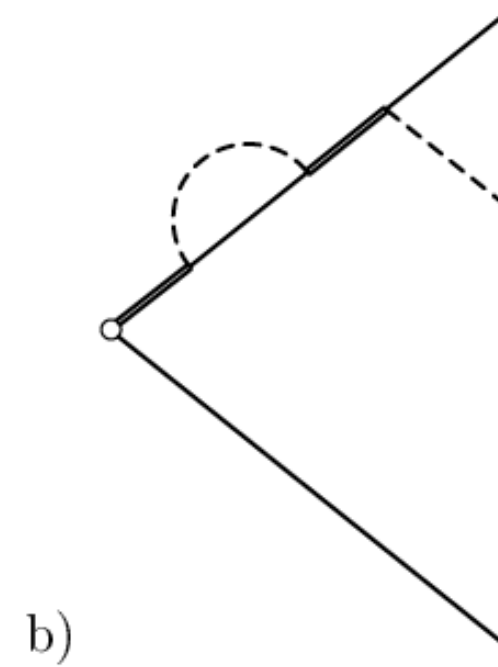
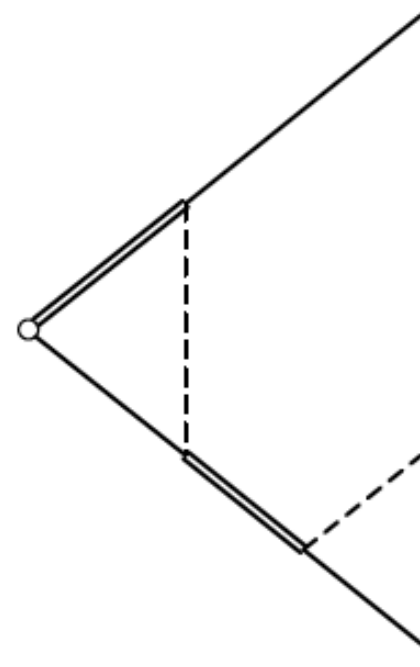

Wavefunction Renormalization

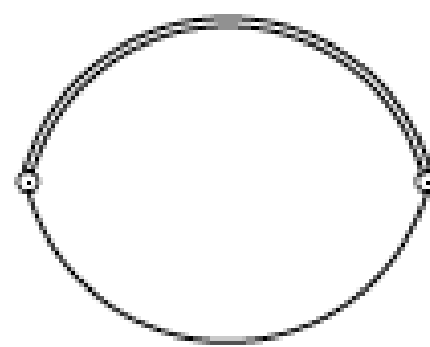

LO

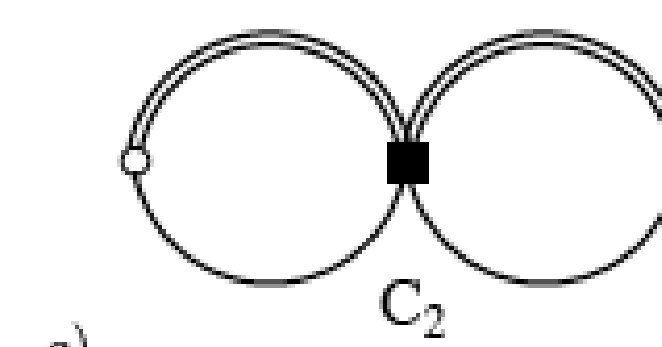
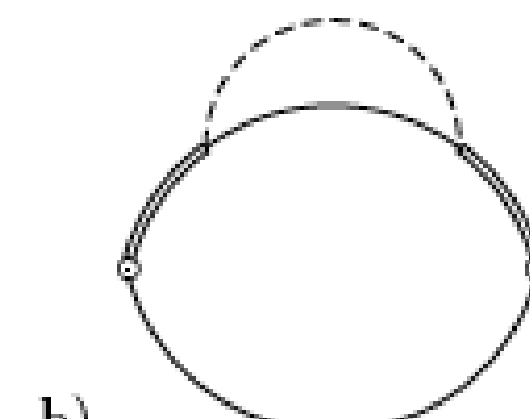
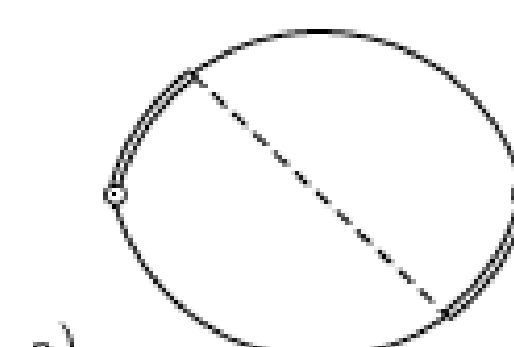

NLO

Revisiting $X(3872) \rightarrow D^0 \bar{D}^0 \pi^0$ in XEFT

L. Dai, F.-K. Guo, TM, Phys. Rev. D. 101 (2020) 5, 054024, arXiv:1912.04317

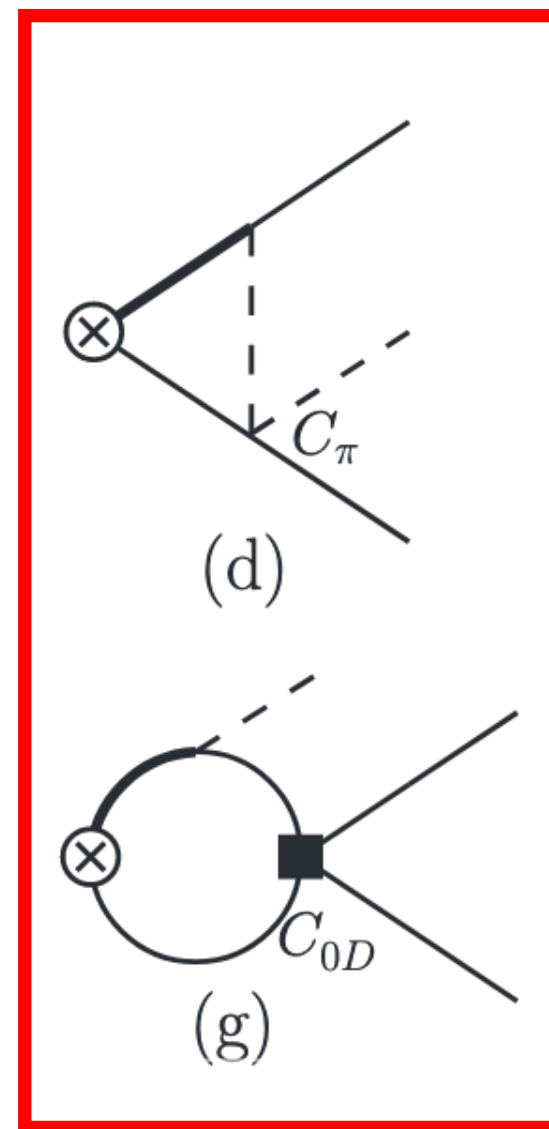
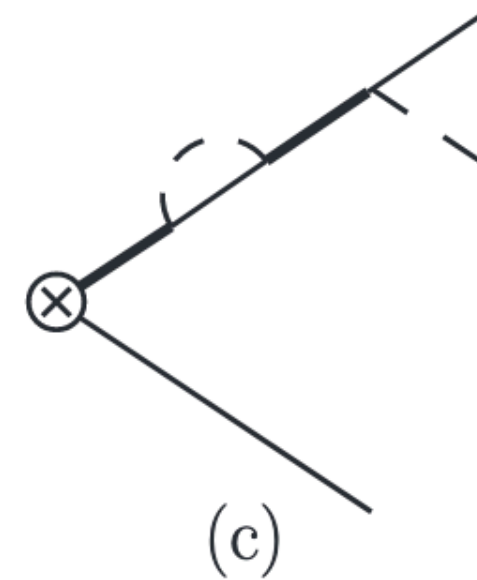
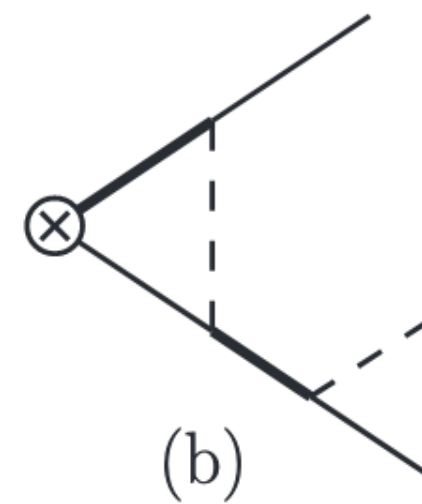
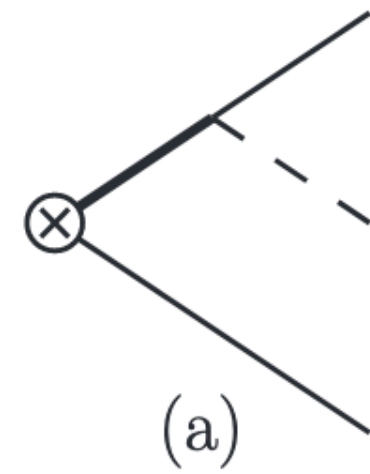

πD rescattering

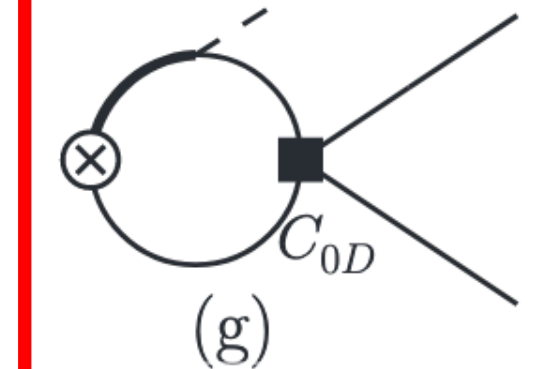
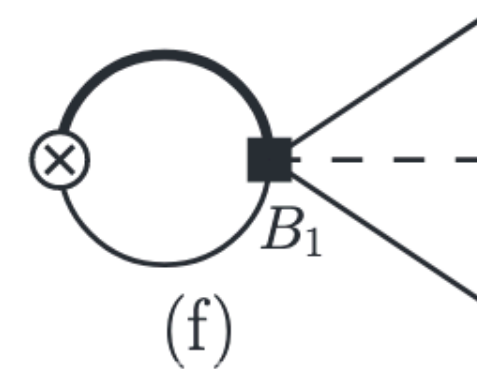
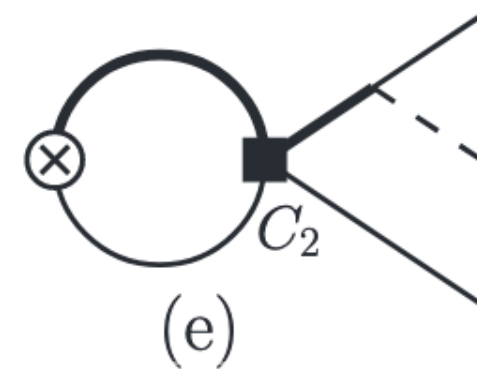

$D\bar{D}$ rescattering

C_π operators had not been known when XEFT as developed,
coefficients recently fixed on lattice

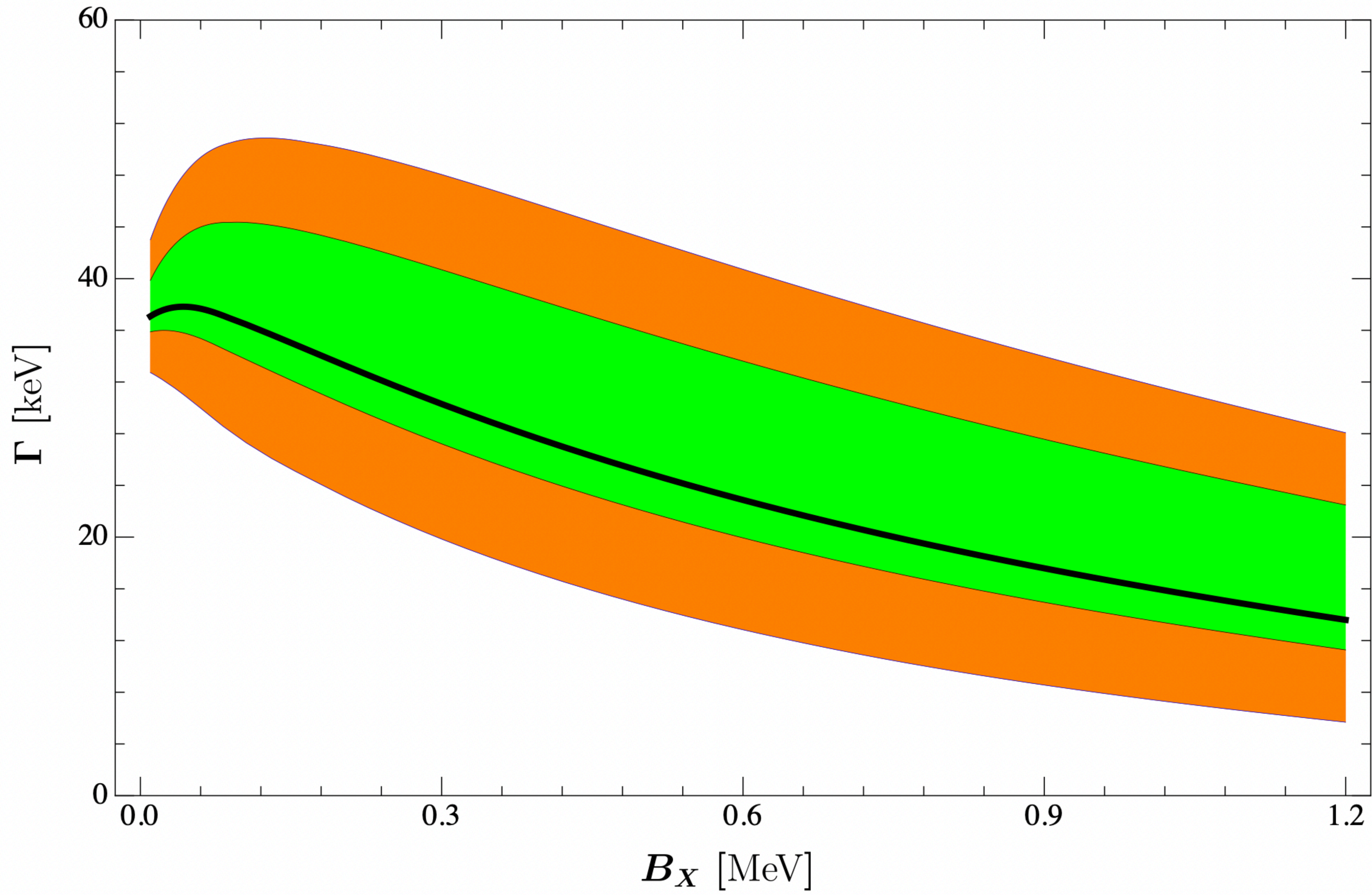

$B_X = 0.05$ [MeV]

$B_X = 0.1$ [MeV]

$B_X = 0.5$ [MeV]

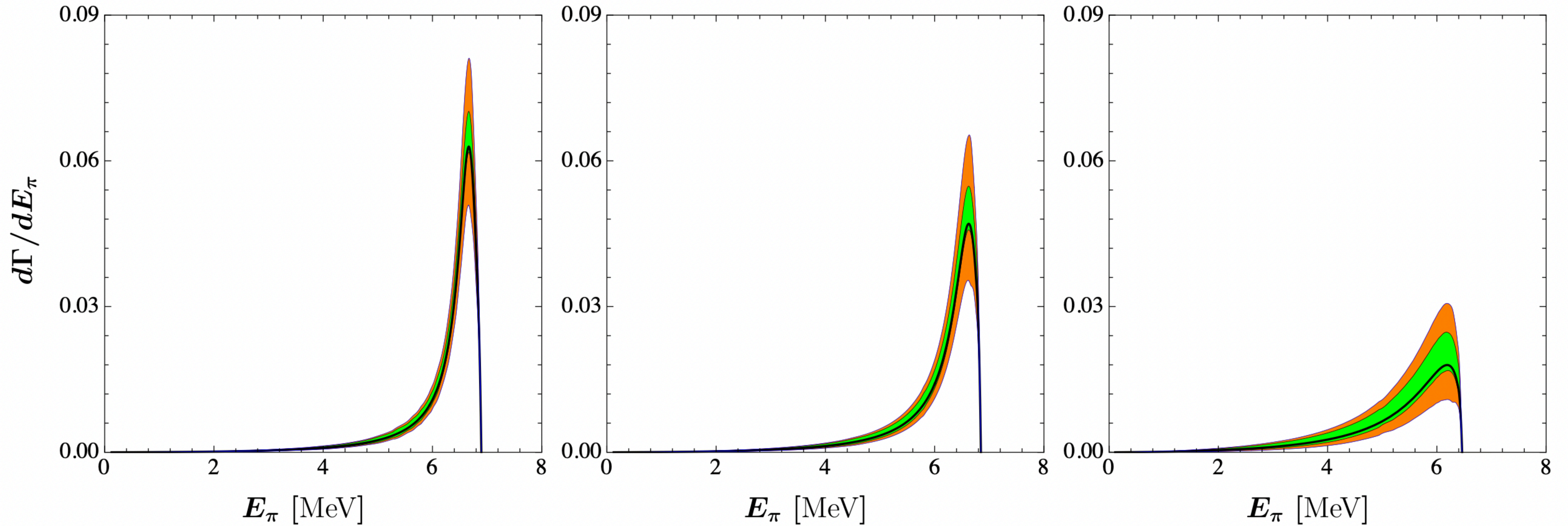

peak location is sensitive to binding energy
insensitive to NLO corrections

$B_X = 0.05$ [MeV]

$B_X = 0.1$ [MeV]

$B_X = 0.5$ [MeV]

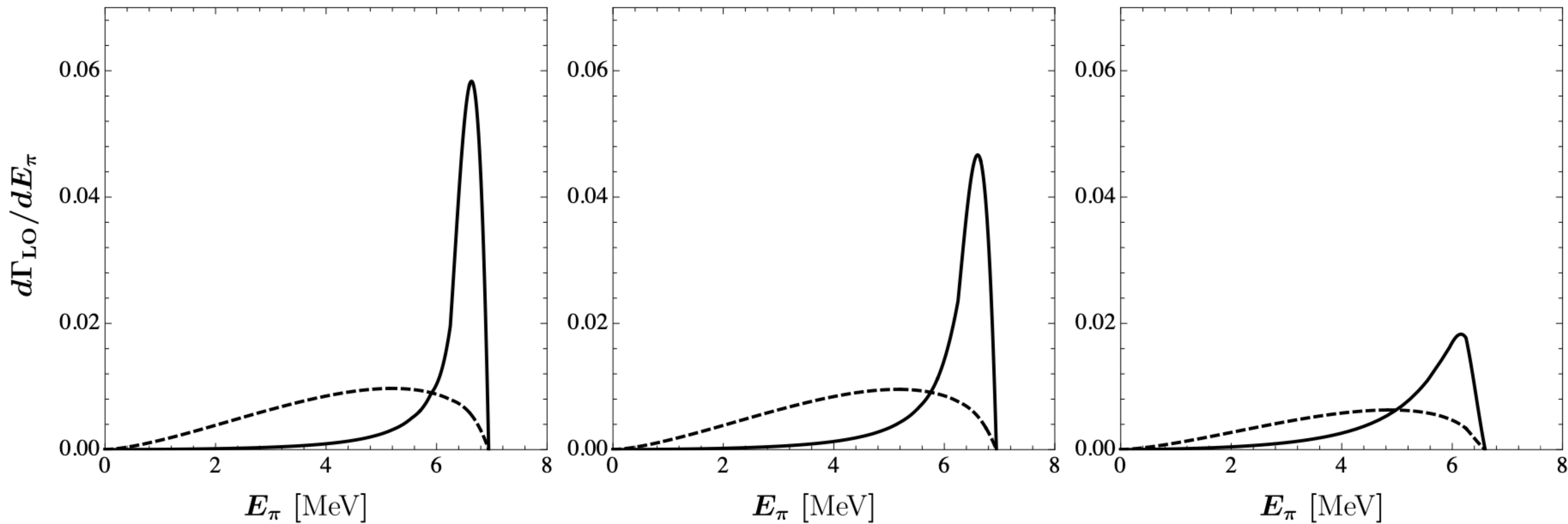

dashed line - phase space times p_π^2

Effective Field Theory for T_{cc}^+

Heavy Hadron Chiral Perturbation Theory
plus contact terms for S-wave D^*D scattering

$$\begin{aligned}\mathcal{L} = & H^{*i\dagger} \left(i\partial^0 + \frac{\nabla^2}{2m_{H^*}} - \delta^* \right) H^{*i} + H^\dagger \left(i\partial^0 + \frac{\nabla^2}{2m_H} - \delta \right) H \\ & + \frac{g}{f_\pi} H^\dagger \partial^i \pi H^{*i} + \text{h.c.} + \frac{1}{2} H^\dagger \mu_D \vec{B}^i H^{*i} + \text{h.c.} \\ & - C_0 (H^{*T} \tau_2 H)^\dagger (H^{*T} \tau_2 H) - C_1 (H^{*T} \tau_2 \tau_a H)^\dagger (H^{*T} \tau_2 \tau_a H).\end{aligned}$$

$$H = \begin{pmatrix} D^0 \\ D^+ \end{pmatrix}, \quad H^{*i} = \begin{pmatrix} D^{*0i} \\ D^{*+i} \end{pmatrix}$$

S. Fleming, R. Hodges, TM, Phys. Rev. D. 104 (2021) 11, 116010, arXiv:2109.02188

Similar to XEFT for $X(3872)$, new feature is coupled channels

T-Matrix for D*D scattering

$$T = \frac{1}{E + E_T} \begin{pmatrix} g_0^2 & g_0 g_+ \\ g_0 g_+ & g_+^2 \end{pmatrix} \quad g_0^2 \Sigma'_0(-E_T) + g_+^2 \Sigma'_+(-E_T) = 1;$$

Tune interactions to produce pole at T_{cc}^+

Decay Diagrams

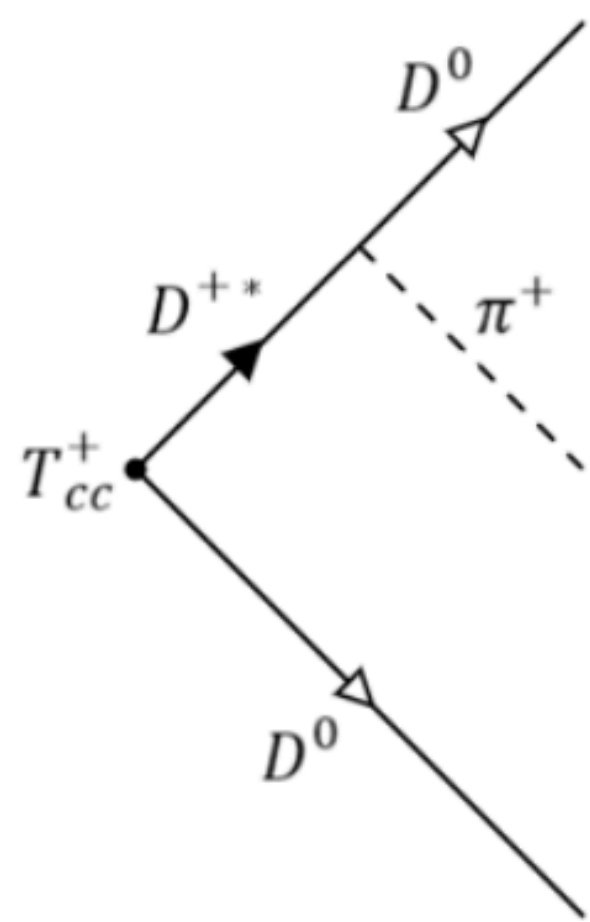

(a)

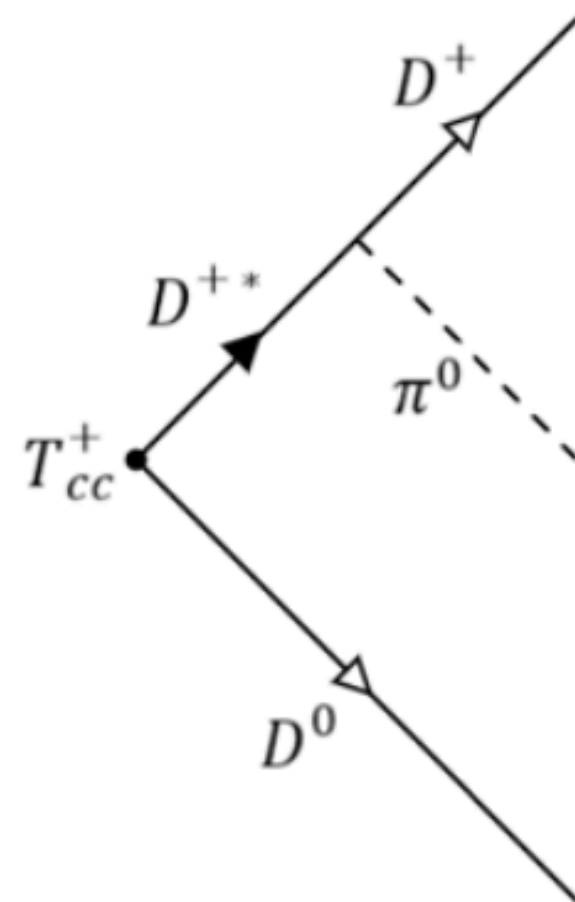

(b)

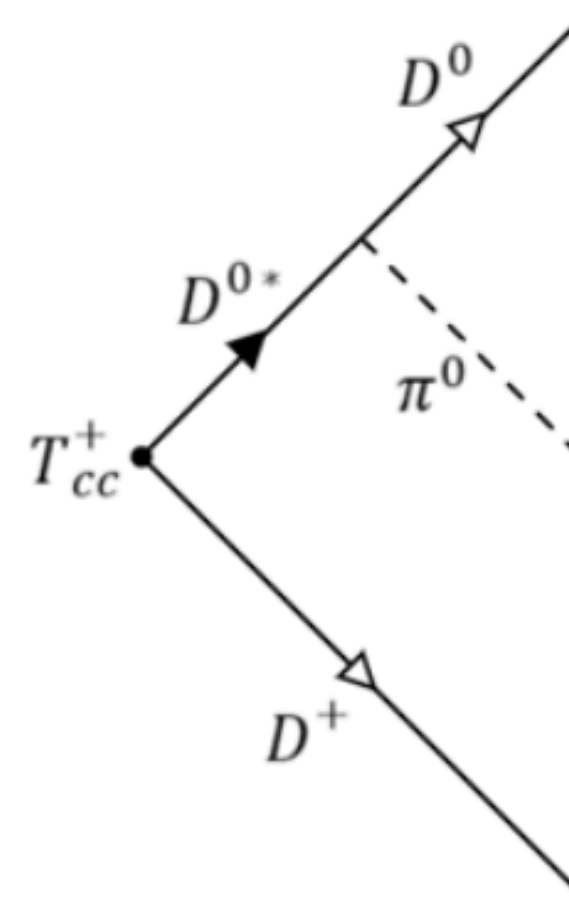

(c)

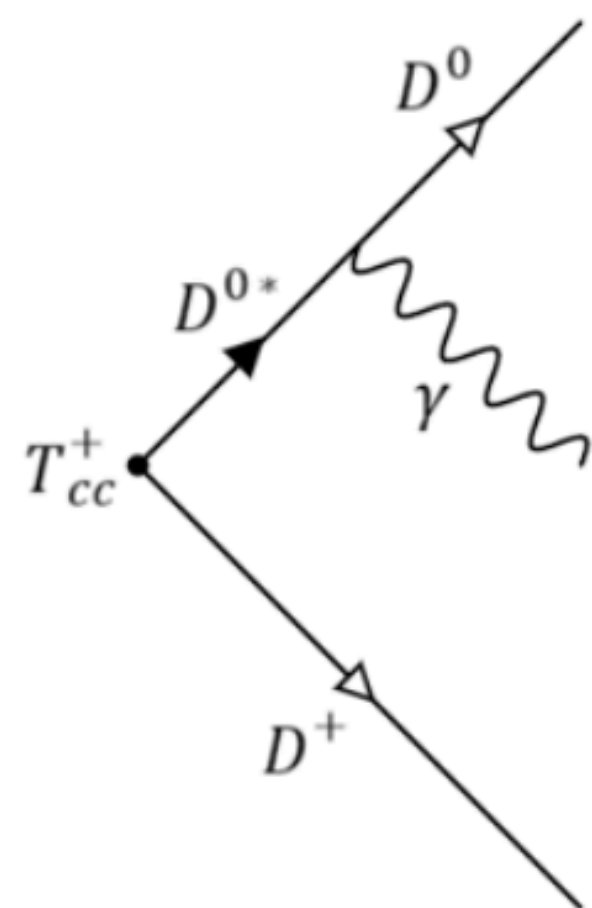

(d)

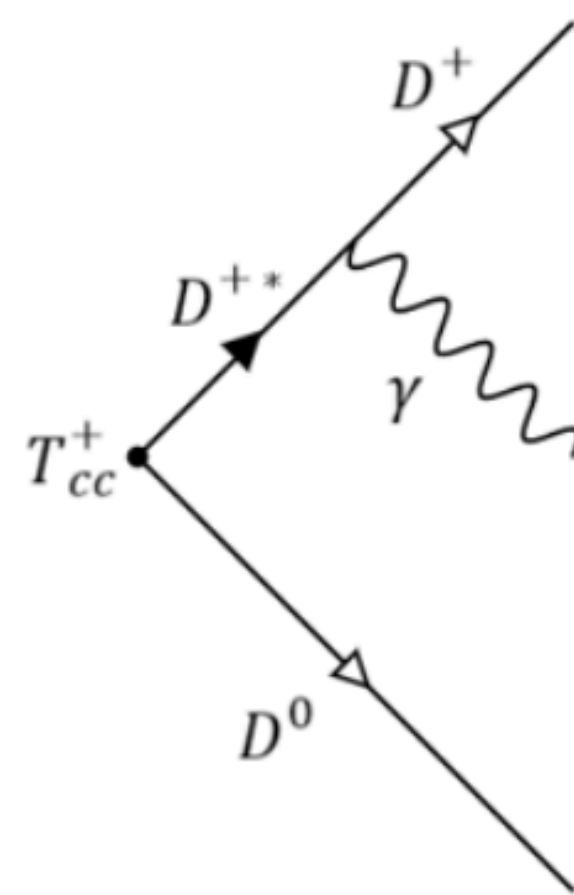

(e)

Decay rate formulae

$$\frac{d\Gamma[T_{cc}^+ \rightarrow D^0 D^0 \pi^+]}{dp_{D_1^0}^2 dp_{D_2^0}^2} = c_\theta^2 \frac{g^2}{(4\pi f_\pi)^2} \frac{2\gamma_0 p_\pi^2}{3} \left[\frac{1}{p_{D_1^0}^2 + \gamma_0^2} + \frac{1}{p_{D_2^0}^2 + \gamma_0^2} \right]^2 ,$$

$$\frac{d\Gamma[T_{cc}^+ \rightarrow D^+ D^0 \pi^0]}{dp_{D^+}^2 dp_{D^0}^2} = \frac{g^2}{(4\pi f_\pi)^2} \frac{2p_\pi^2}{3} \left[\frac{\sqrt{\gamma_0} c_\theta}{p_{D^+}^2 + \gamma_0^2} - \frac{\sqrt{\gamma_+} s_\theta}{p_{D^0}^2 + \gamma_+^2} \right]^2 ,$$

$$\frac{d\Gamma[T_{cc}^+ \rightarrow D^+ D^0 \gamma]}{dp_{D^+}^2 dp_{D^0}^2} = \frac{E_\gamma^2}{6\pi^2} \left[\frac{\sqrt{\gamma_0} c_\theta \mu_{D^0}}{p_{D^+}^2 + \gamma_0^2} - \frac{\sqrt{\gamma_+} s_\theta \mu_{D^+}}{p_{D^0}^2 + \gamma_+^2} \right]^2 .$$

$$\gamma_0^2 = 2\mu_0(m_{D^0} + m_{D^{*+}} - m_T)$$

$$\gamma_+^2 = 2\mu_+(m_{D^+} + m_{D^{*0}} - m_T)$$

$$g_0^2 = \frac{\cos^2 \theta}{\Sigma'_0(-E_T)}$$

$$g_+^2 = \frac{\sin^2 \theta}{\Sigma'_+(-E_T)} ;$$

$$i\Sigma_i(E) =$$

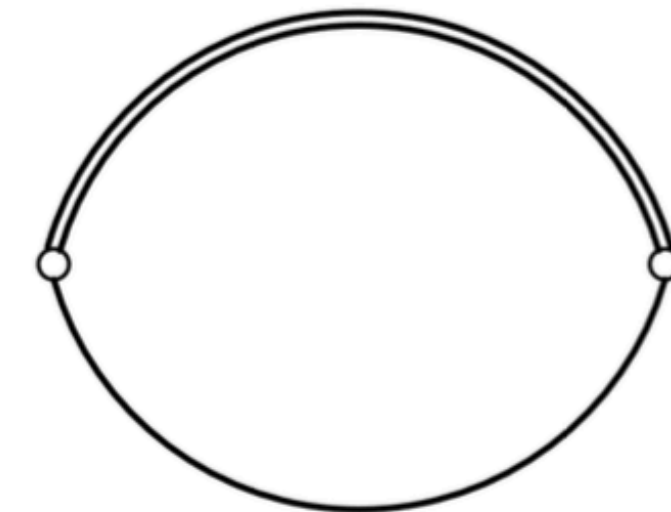

LO Predictions for Decay Rate

	I=0	I=1	Γ_{\max}
θ	-32.4°	32.4°	-8.34°
$\Gamma[T_{cc}^+ \rightarrow D^0 D^0 \pi^+]$	32	32	44
$\Gamma[T_{cc}^+ \rightarrow D^+ D^0 \pi^0]$	15	3.8	13
$\Gamma[T_{cc}^+ \rightarrow D^+ D^0 \gamma]$	6.1	2.8	1.9
$\Gamma[T_{cc}^+]$	52	38	58

$$I = 0 : g_0 = -g_+$$

$$I = 1 : g_0 = g_+$$

Other Predictions

	$\Gamma(T_{cc}^+) \text{ (keV)}$
Fleming et al.	52
Meng et al.	$46.7_{-2.9}^{+2.7}$
Ling et al.	53
Feijoo et al.	43
Yan & Valderrama	49 ± 16
Albaladejo	77

$$\delta m_{BW} = -273 \pm 61 \pm 5_{-14}^{+11} \text{ keV},$$

$$\Gamma_{BW} = 410 \pm 165 \pm 43_{-38}^{+18} \text{ keV}. \quad (1)$$

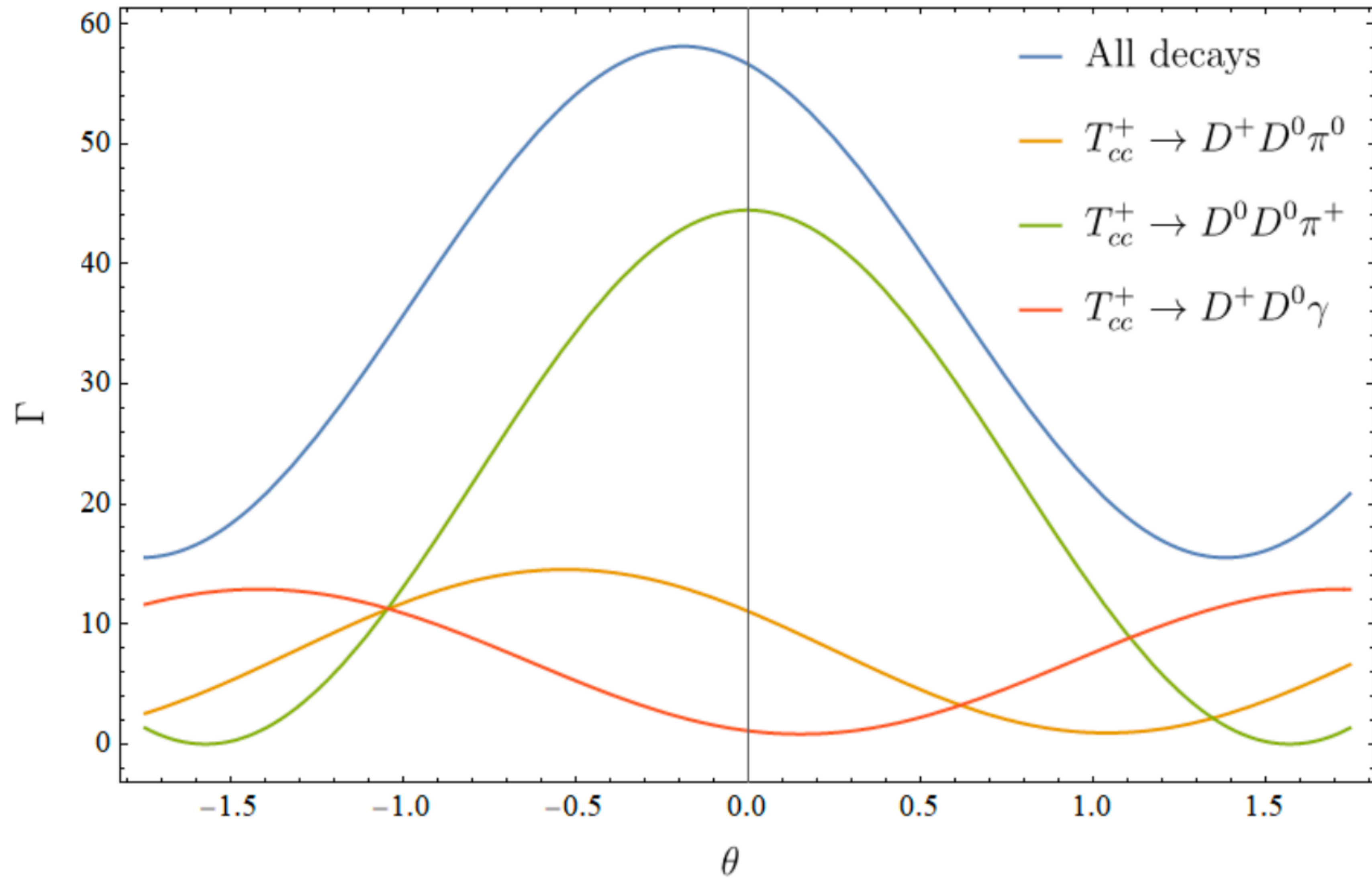

this agrees well with the same plot by Meng et al. (2107.14784)

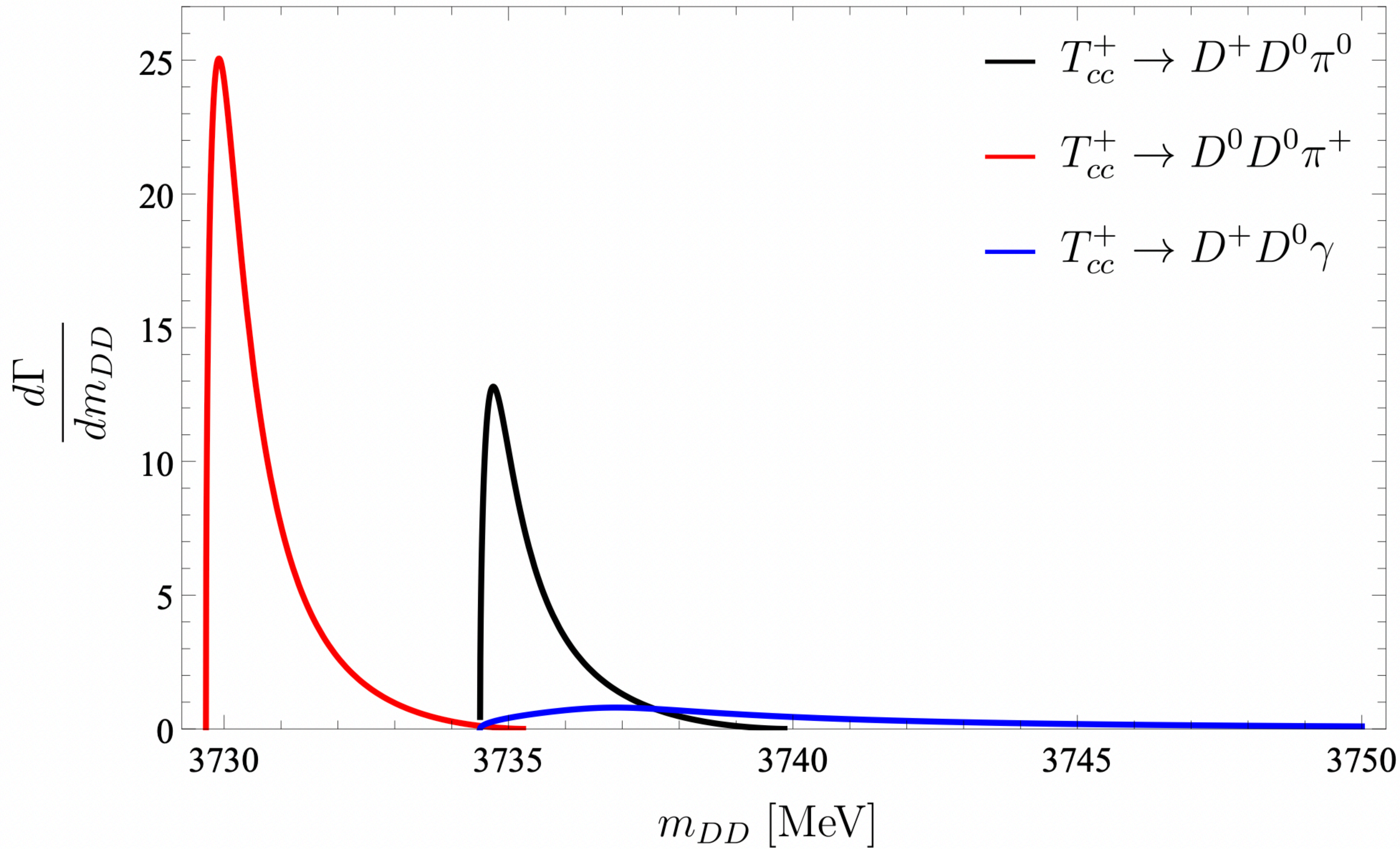

$d\Gamma/dm_{DD}$ vs. data

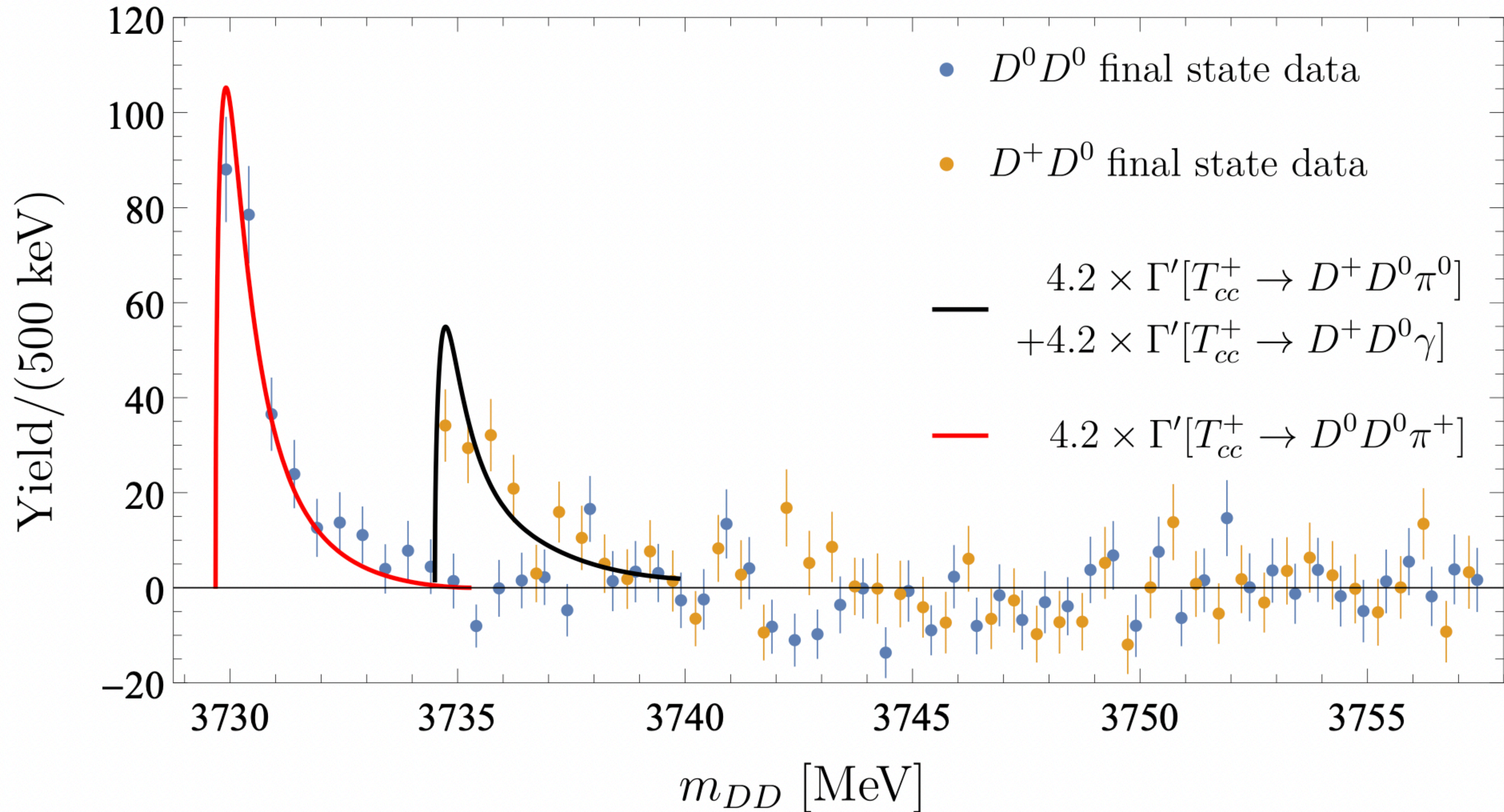

see also M.-L. Du, et.al., Phys. Rev. D, 105 (2022) 1, 014024

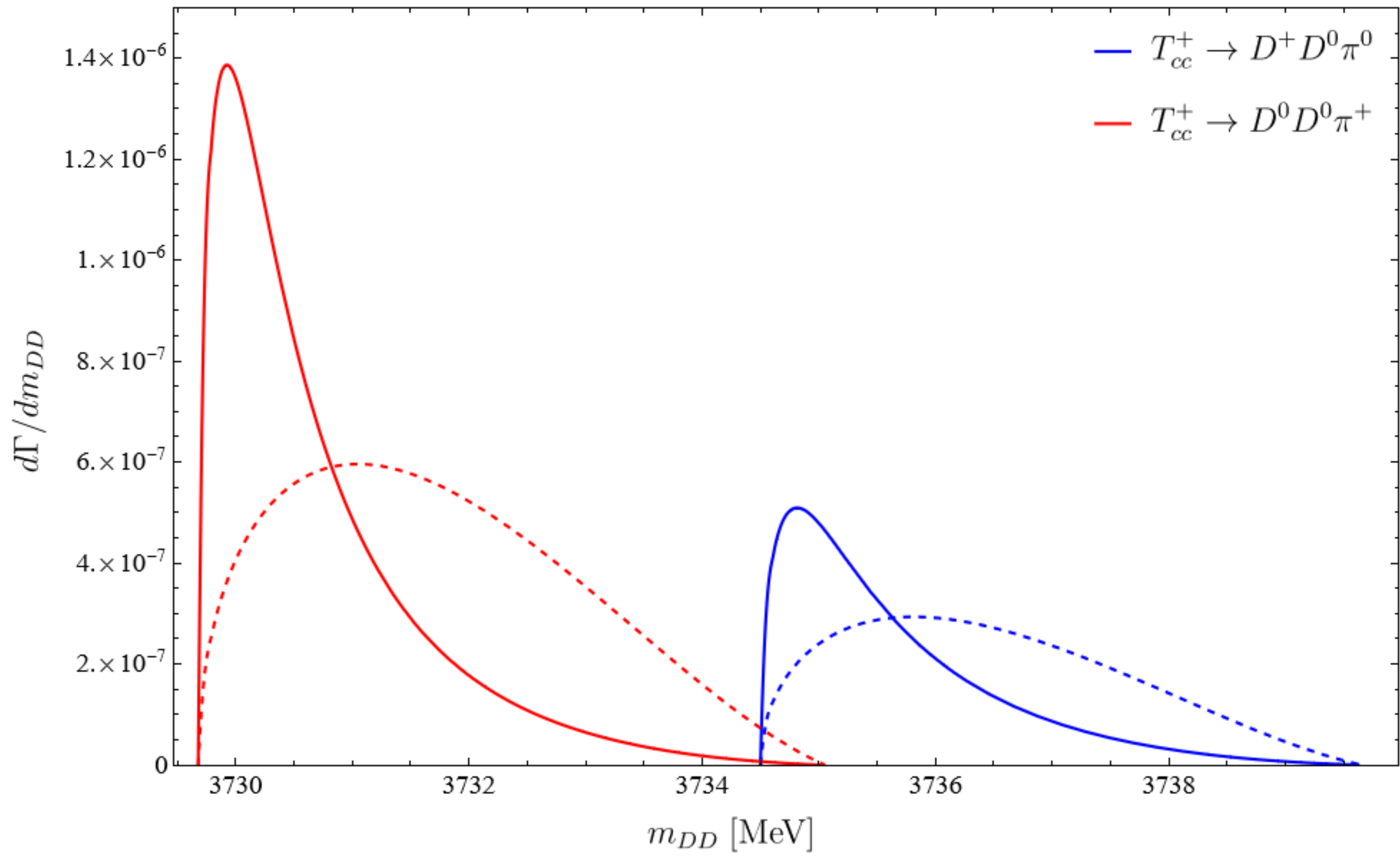

comparison with $p_\pi^2 \times$ phase space (dashed)

NLO Corrections to Decay Rate - assume $l = 0$ state

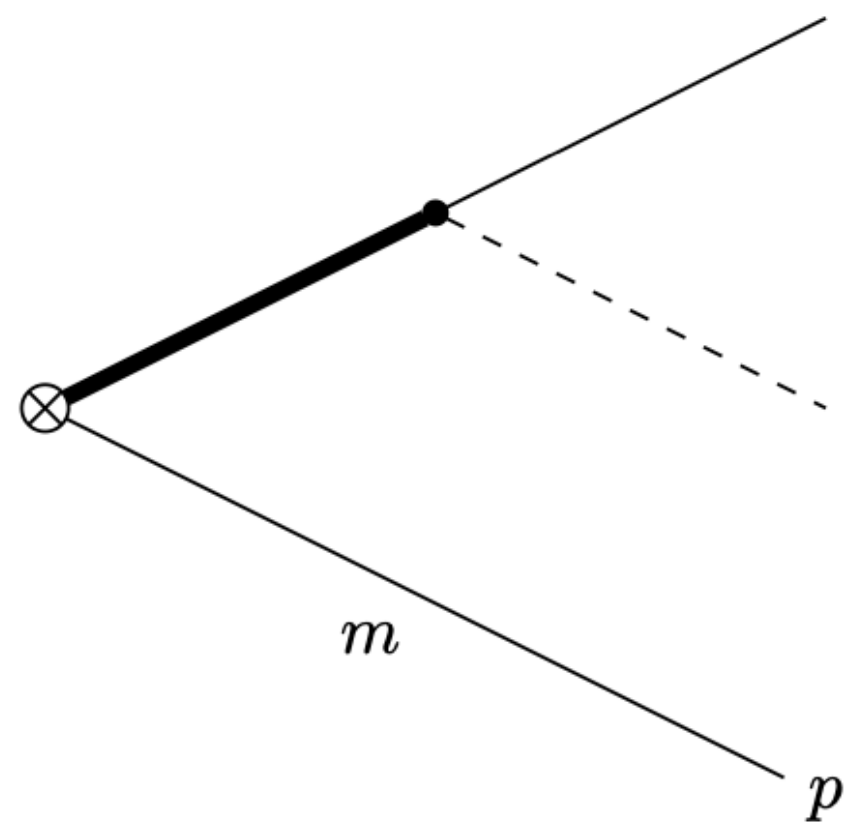

(a)

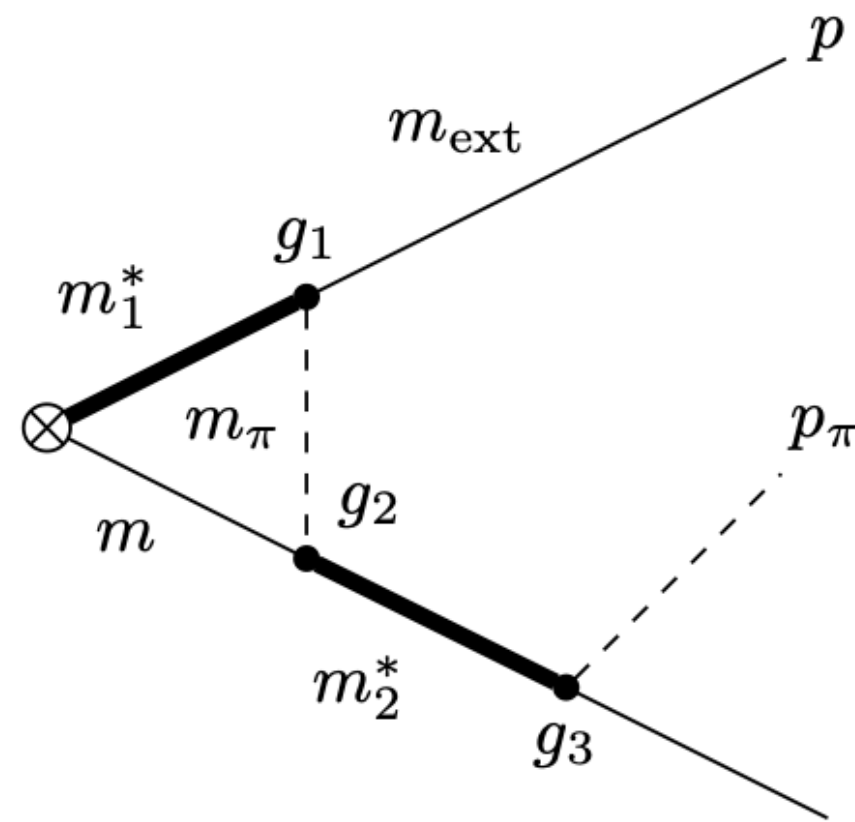

(b)

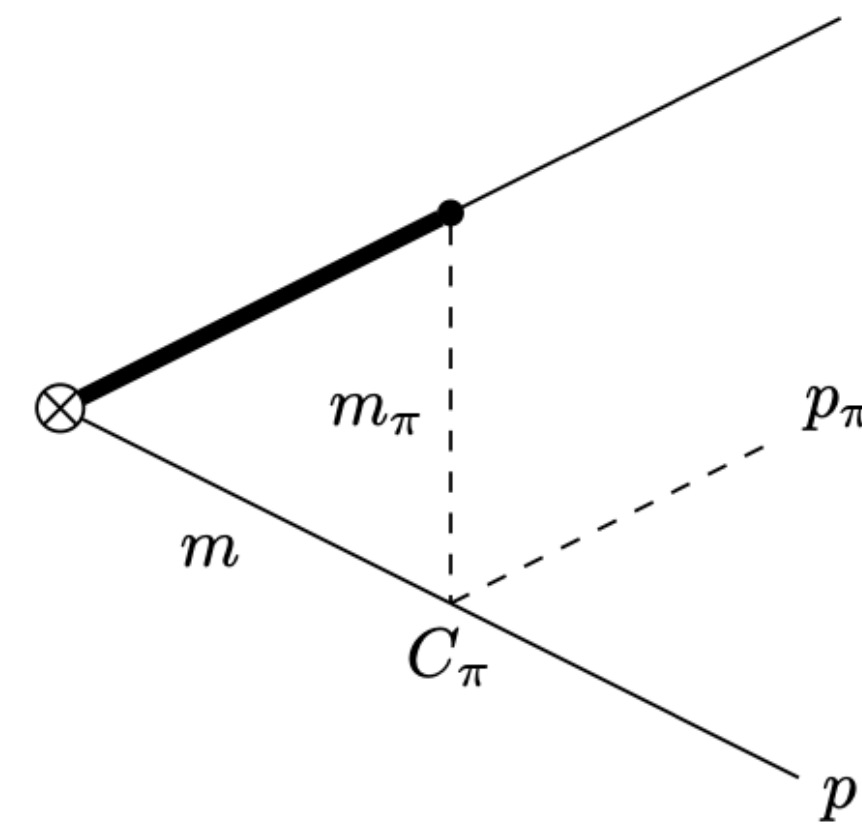

(c)

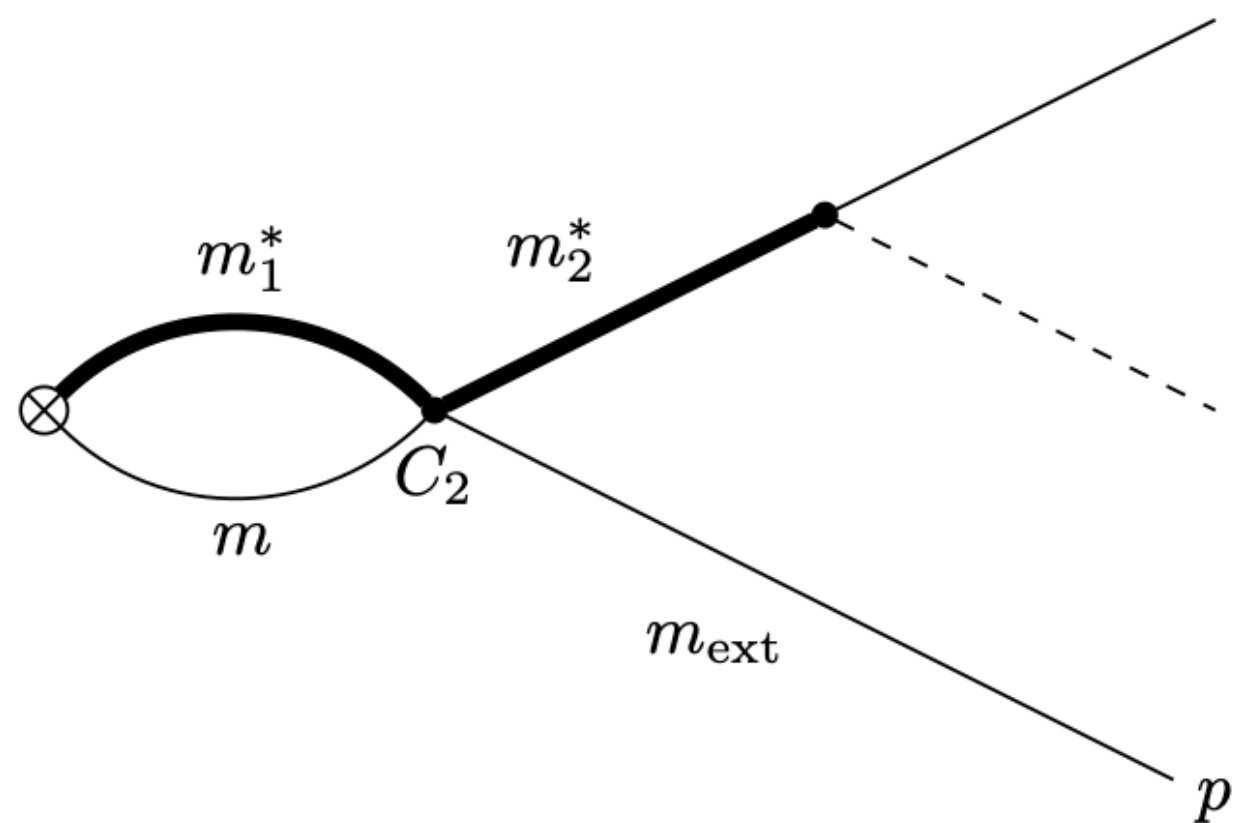

(d)

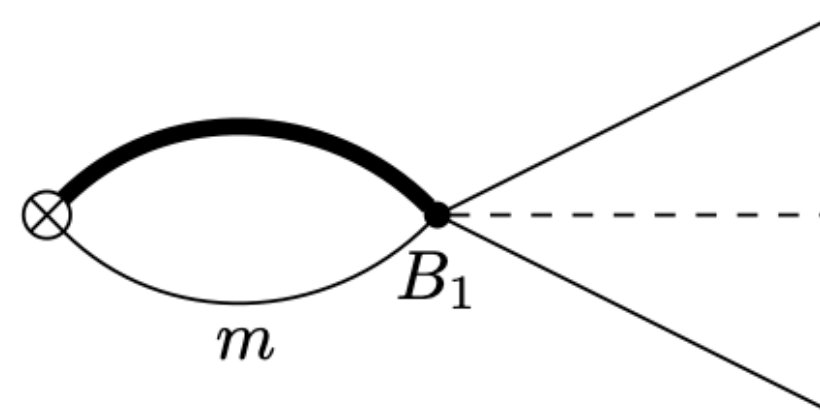

(e)

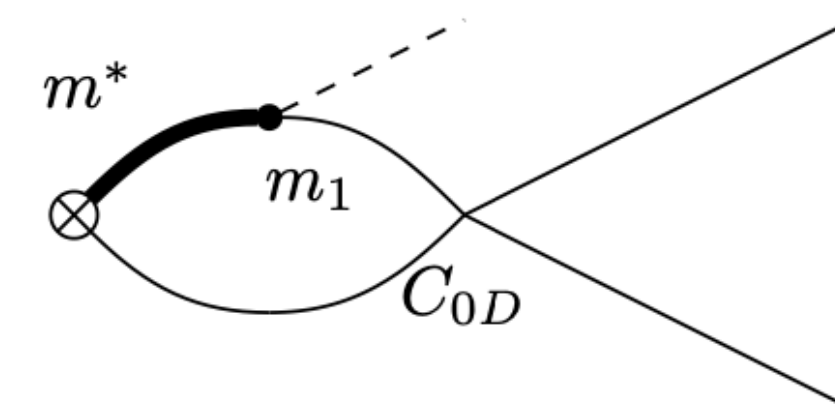

(f)

$$\Gamma_0 \approx \Gamma^{LO} \left(1 - \frac{\text{Re } \Sigma_0'^{NLO}(-E_T)}{\text{Re tr } \Sigma'^{LO}(-E_T)} \right) + \frac{2 \text{Im } \Sigma_0^{NLO}(-E_T)}{\text{Re tr } \Sigma'^{LO}(-E_T)}$$

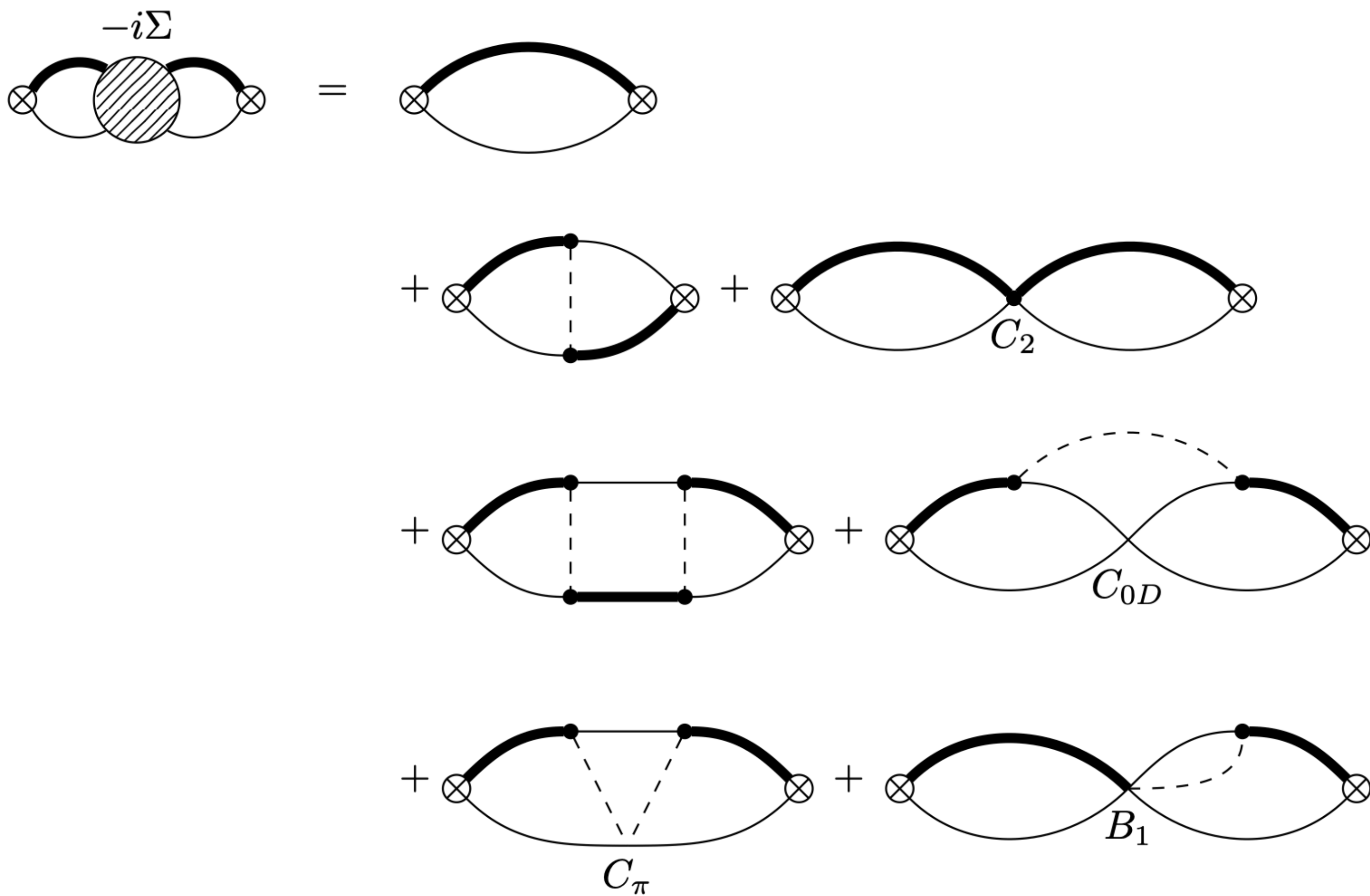

NLO Corrections to Decay Rate

TABLE I: Partial and total widths in units of keV at LO and NLO.

	LO result	NLO lower bound	NLO upper bound
$\Gamma[T_{cc}^+ \rightarrow D^0 D^0 \pi^+]$	28	21	44
$\Gamma[T_{cc}^+ \rightarrow D^+ D^0 \pi^0]$	13	7.8	21
$\Gamma_{\text{strong}}[T_{cc}^+]$	41	29	66
$\Gamma_{\text{strong}}[T_{cc}^+] + \Gamma_{\text{EM}}^{LO}[T_{cc}^+]$	47	35	72

$$\delta m_{pole} = -360 \pm 40_{-0}^{+4} \text{ keV} ,$$

$$\Gamma_{pole} = 48 \pm 2_{-14}^{+0} \text{ keV} . \quad (2)$$

Non – analytic and NLO self – energy contributions

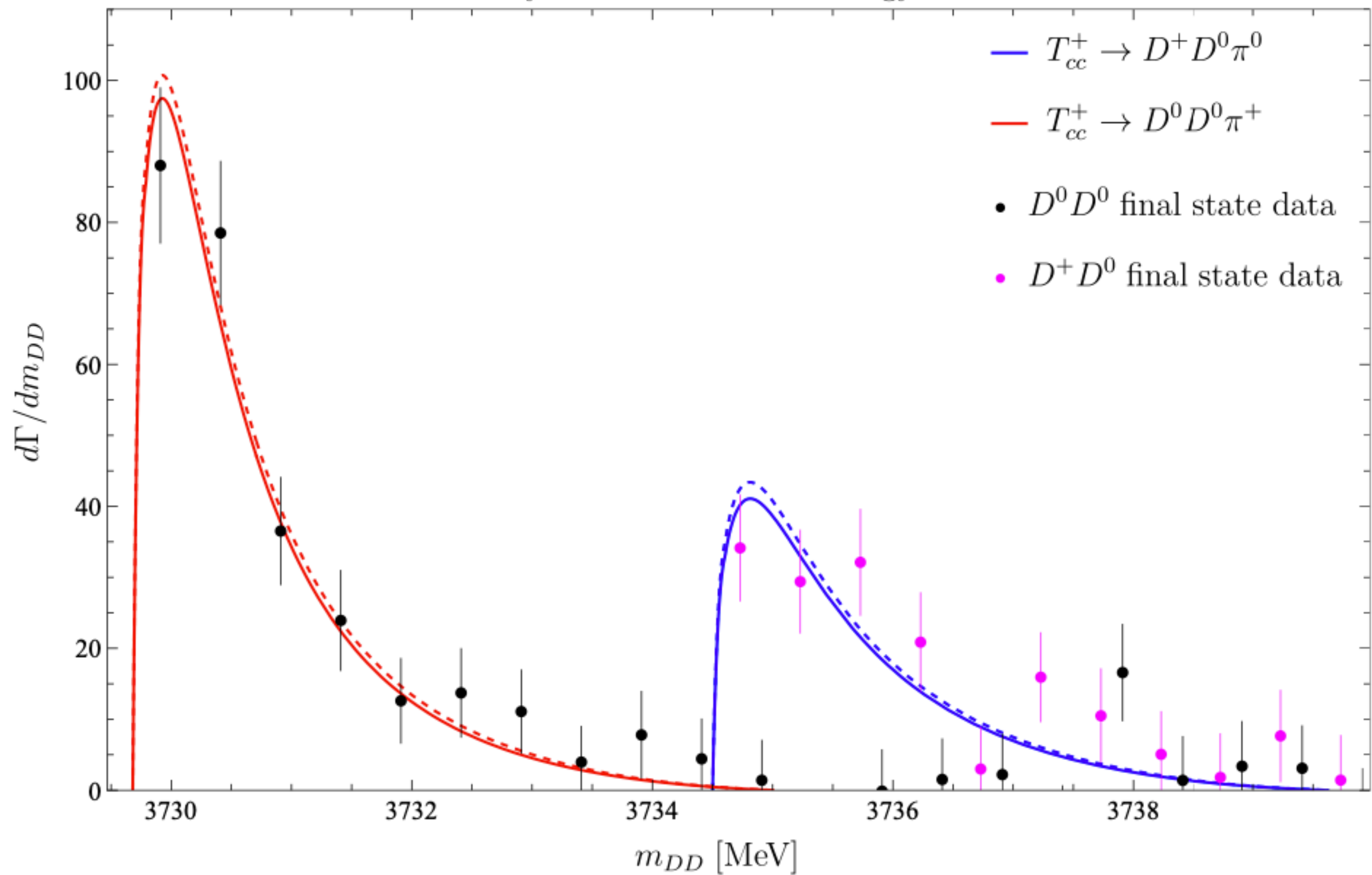

Contributions from C_{0D} interactions

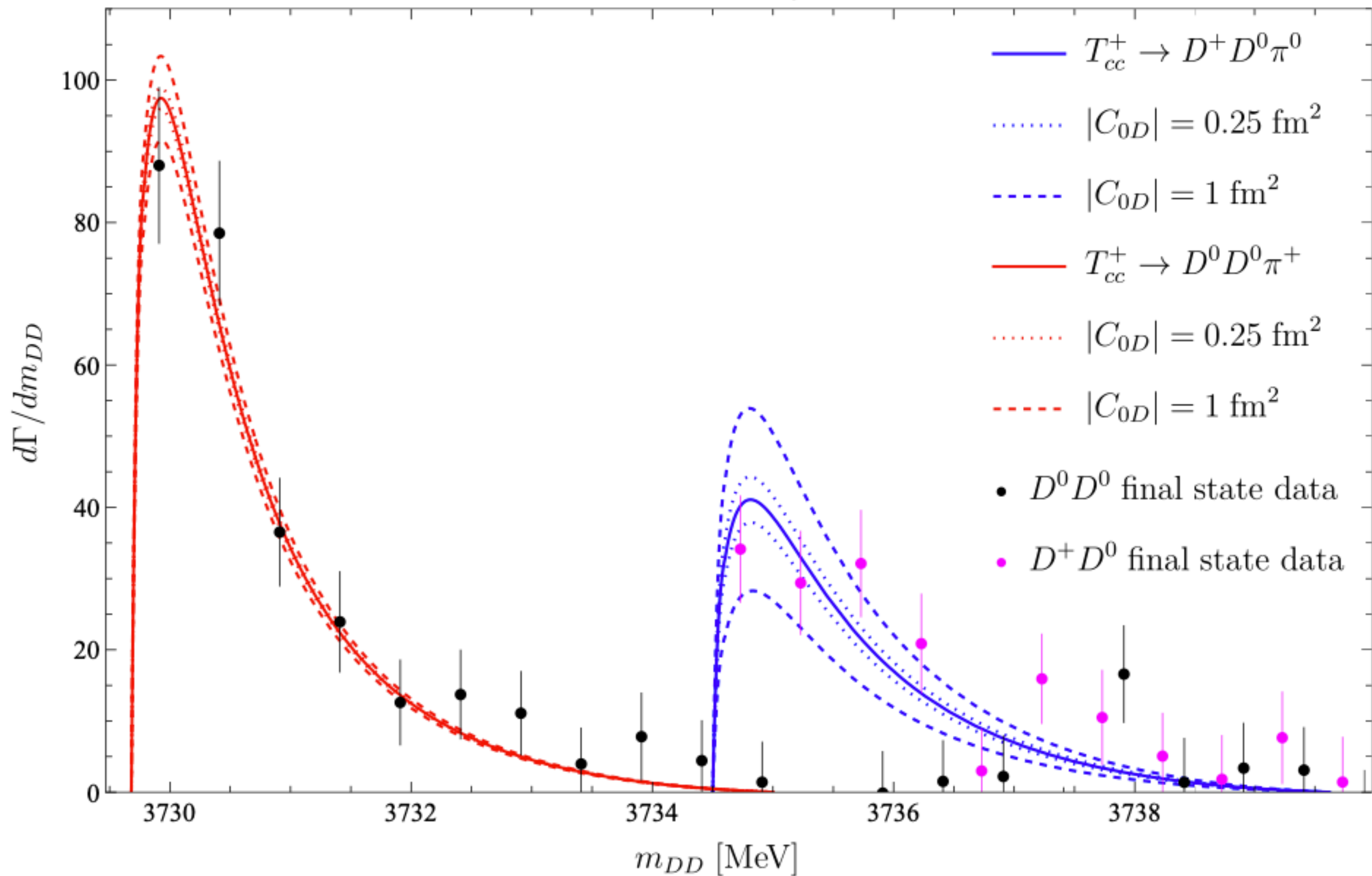

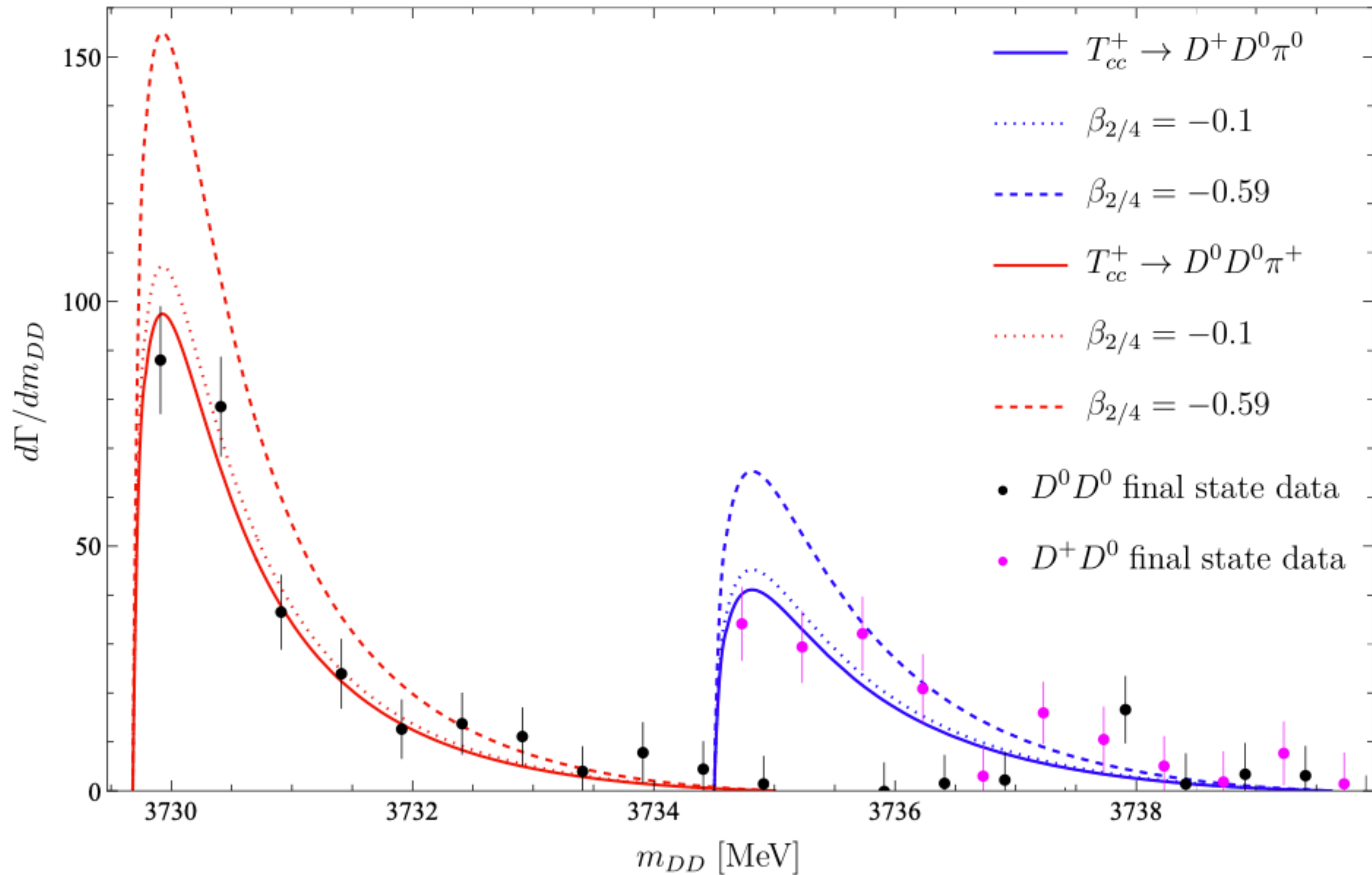
Contributions from β_2 and β_4 

All NLO contributions

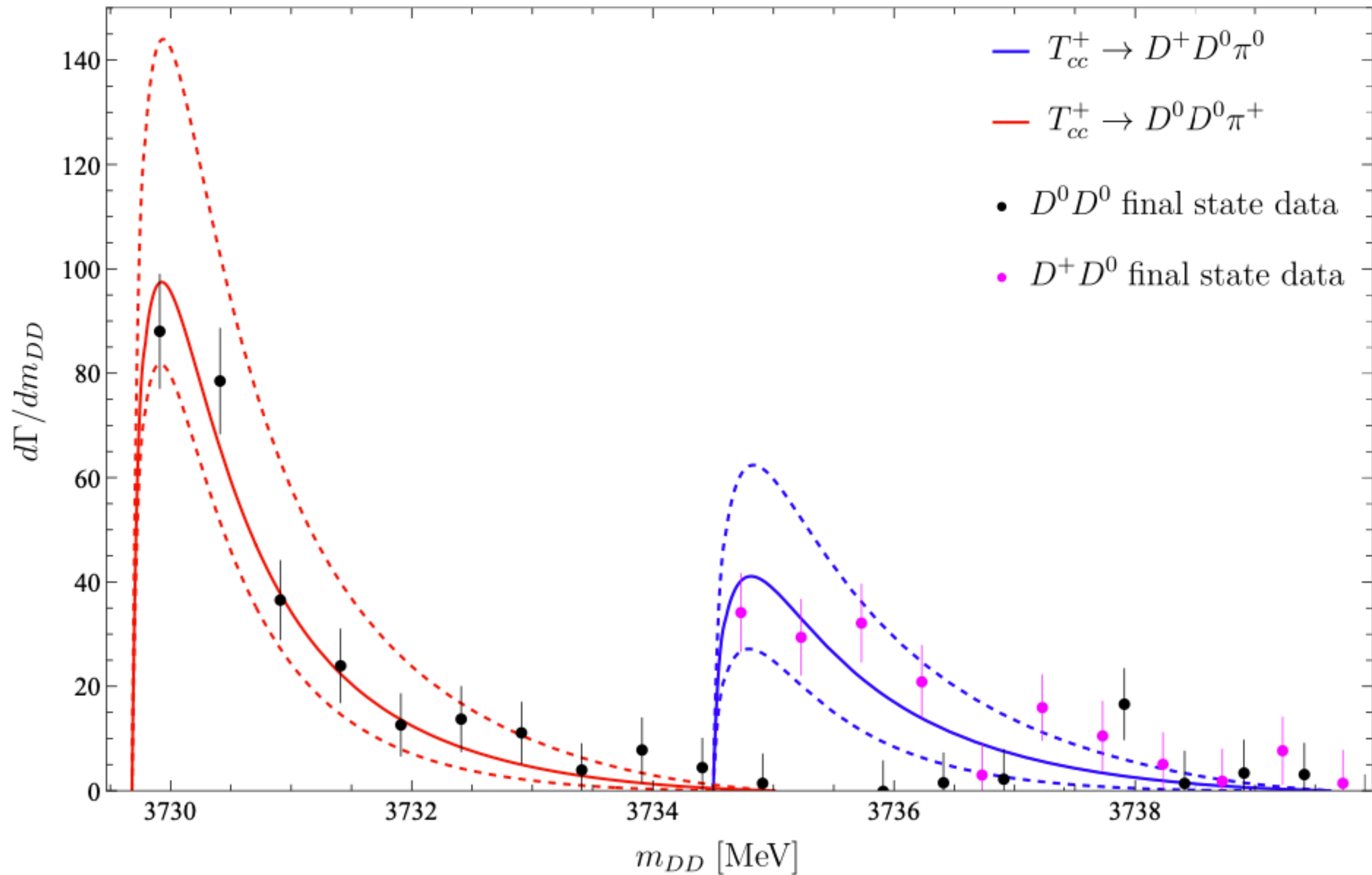

Summary

excellent agreement w/ LO EFT calculations

T_{cc}^+ decays described by XEFT-like theory w/ coupled channels

$$\Gamma[T_{cc}^+], d\Gamma[T_{cc}^+]/dm_{DD}$$

NLO corrections: pion loops

negligible

πD rescattering

negligible

range corrections

dominant

DD rescattering

significant

NLO calculations agree with data, could constrain D interactions