

# A fully integrated FieldCage-Photodetector system for large volume LArTPC experiments

## APEX Concept (Aluminum Profiles with Embedded X-Arapucas)

- Field cage modular unit 3m x 3.2m panel made of Al profiles, as in current DUNE FD modules
- **We propose to retain the LArTPC field cage and integrate photodetector module into it**
  - 0.5m x 0.5m PD module, 6 modules per row share power and readout
    - Granularity adjustable
  - Larger oval shaped FC profiles: keep the max **E** field small
  - **Operate photodetectors on HV surface**
    - **Solution: PoF and SoF technologies (later slides)**
  - Three FRP beams as structural support
    - Center beam also serves as cable conduits

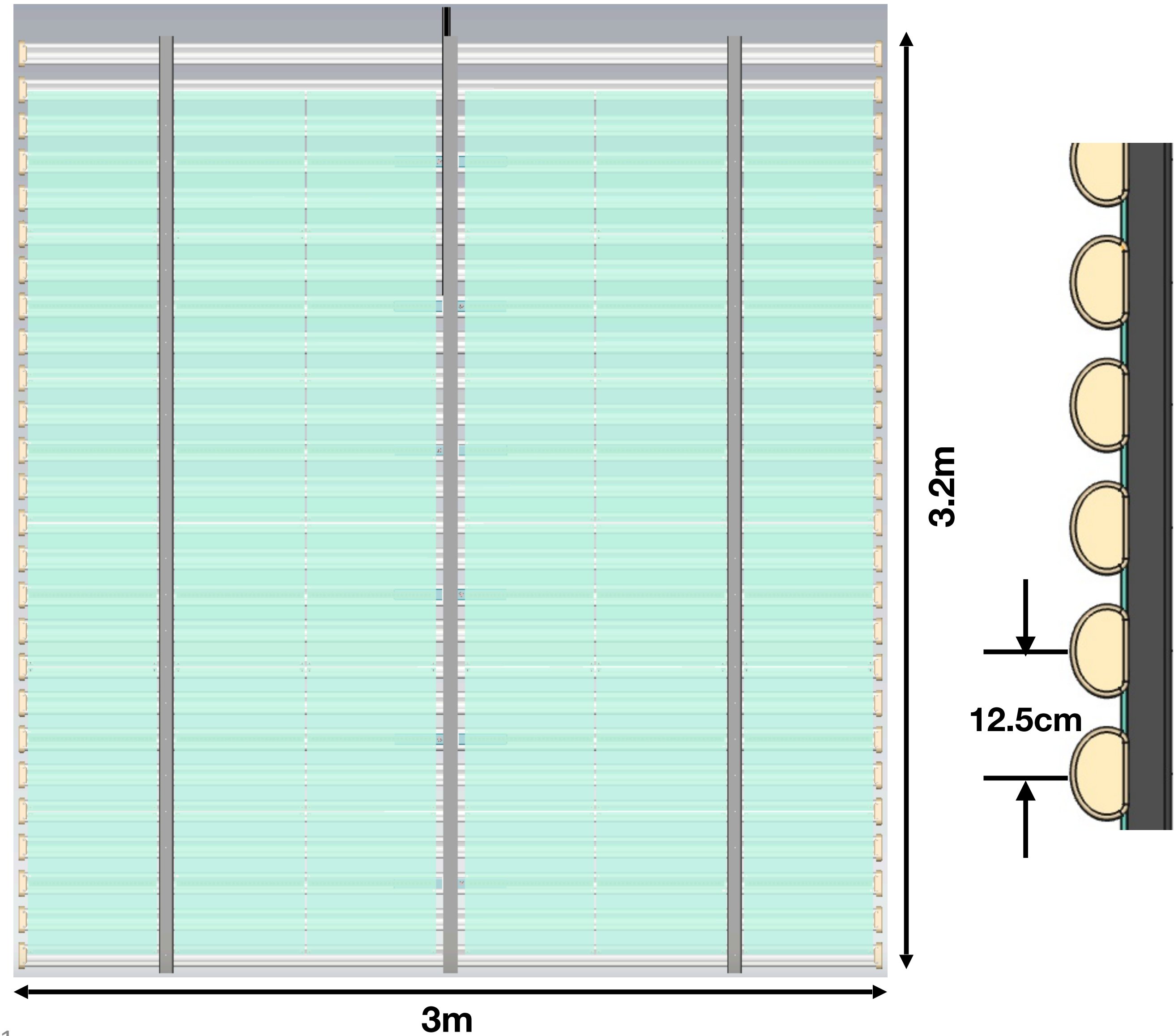

# A fully integrated FieldCage-Photodetector system for large volume LArTPC experiments

## APEX Concept (Aluminum Profiles with Embedded X-Arapucas)

[Reflector - WLS2 - Dichroic - WLS1]  
 VIKUITI foil - PMMA - ALD - pTP film

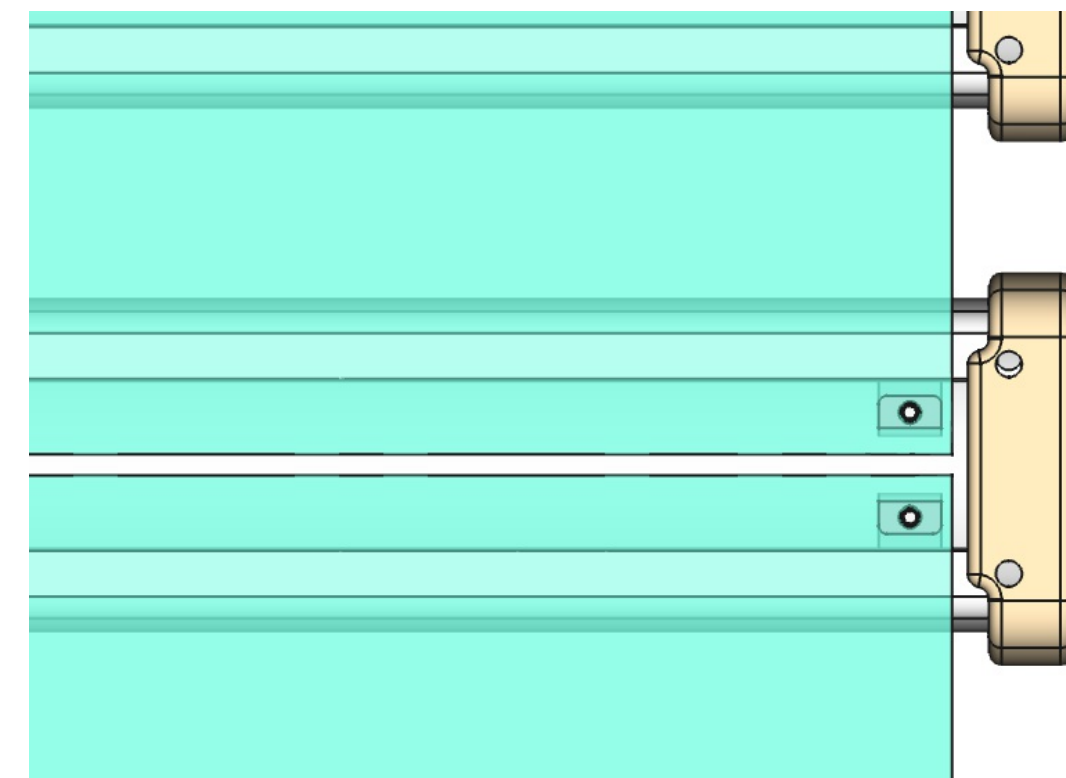
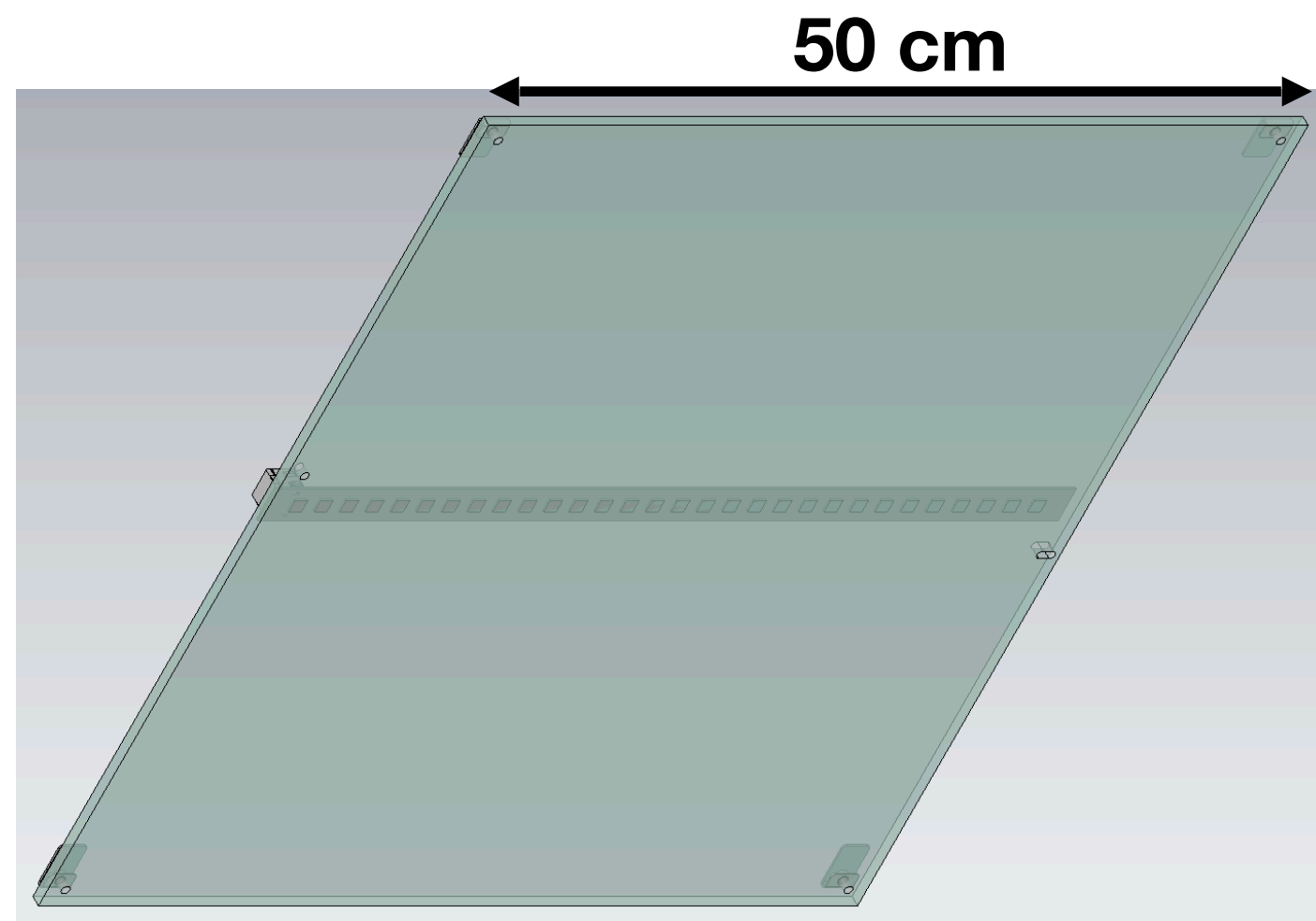

Mounting details

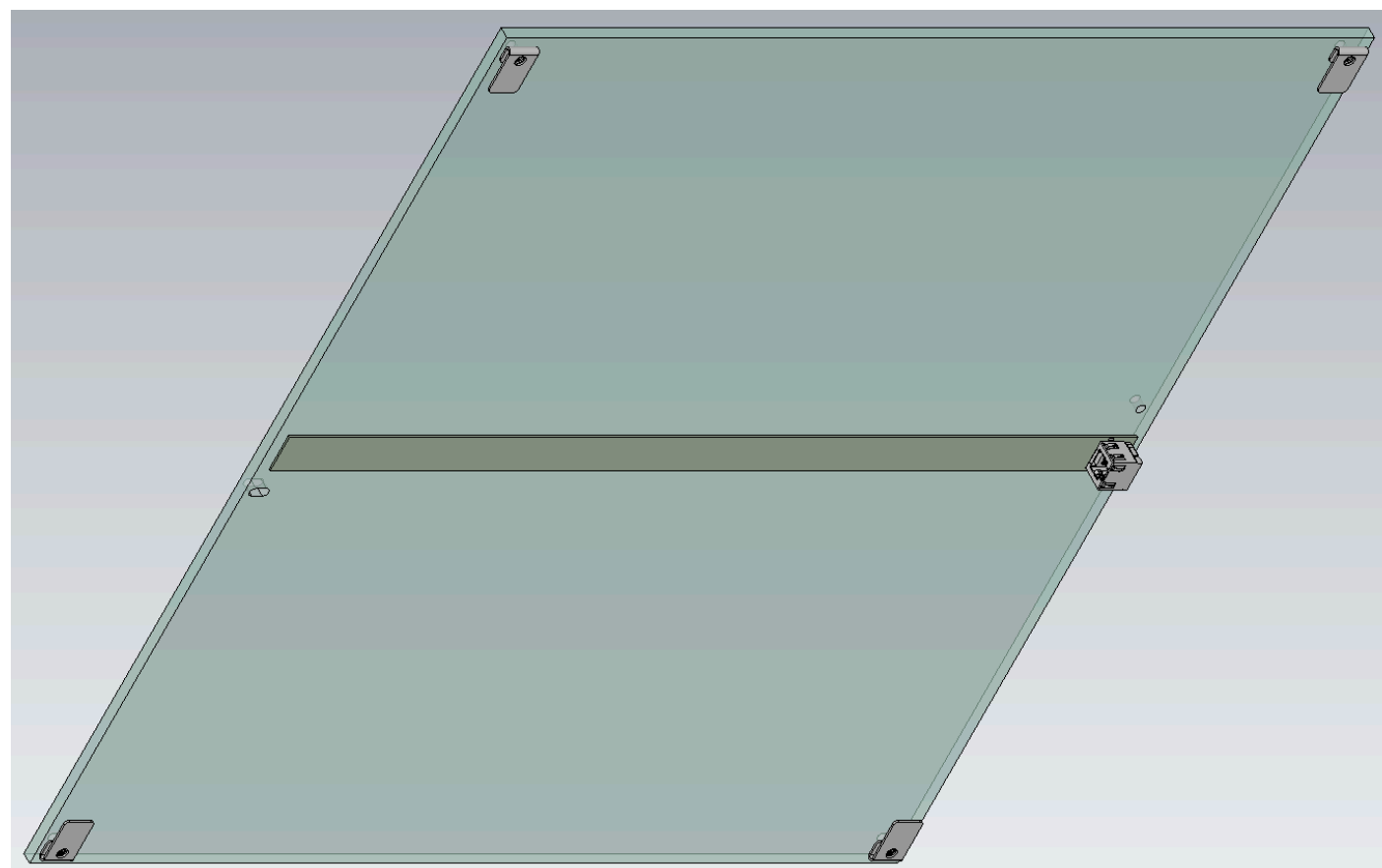
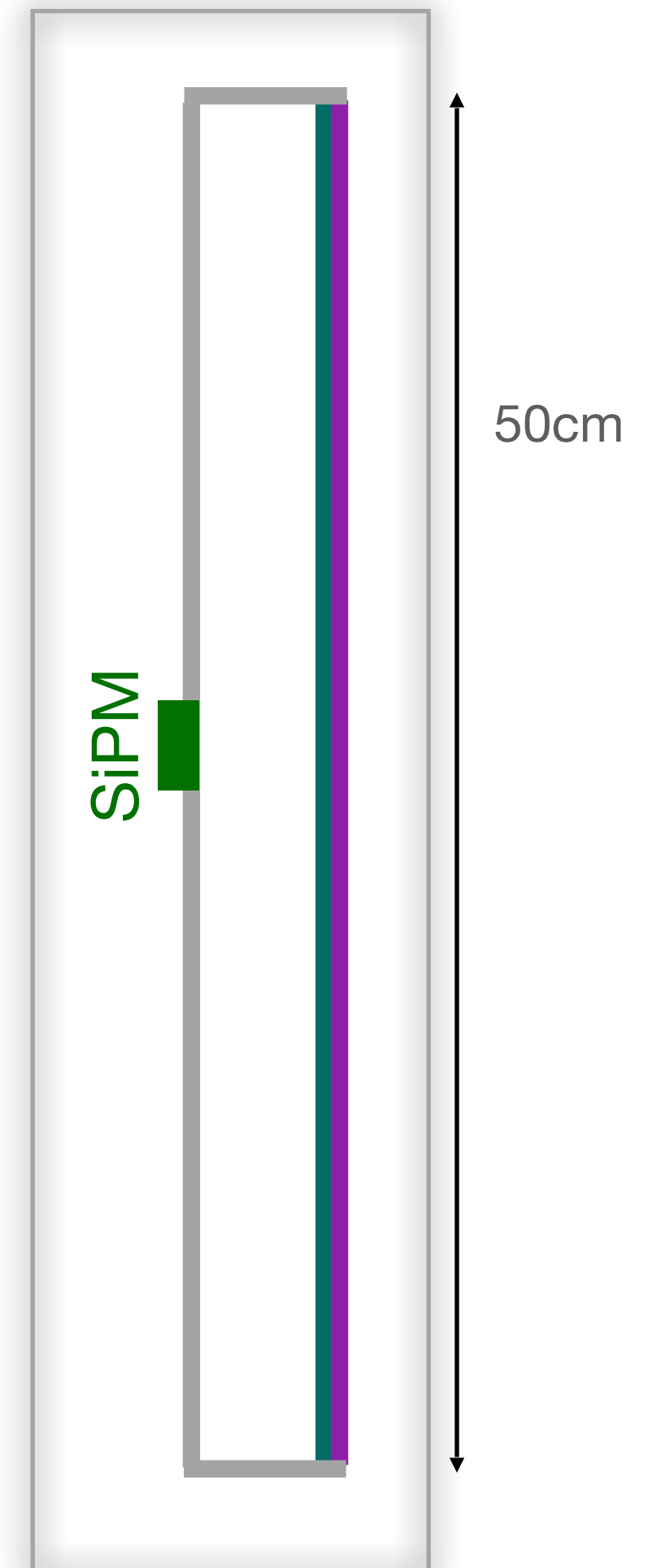
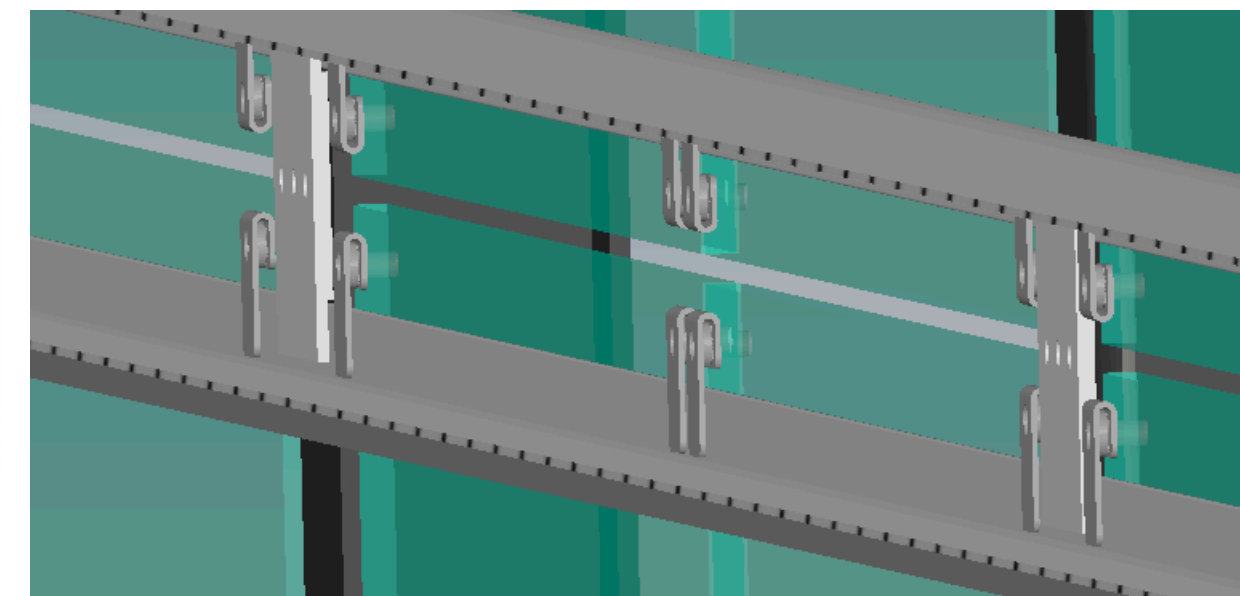

SiPMs at the center

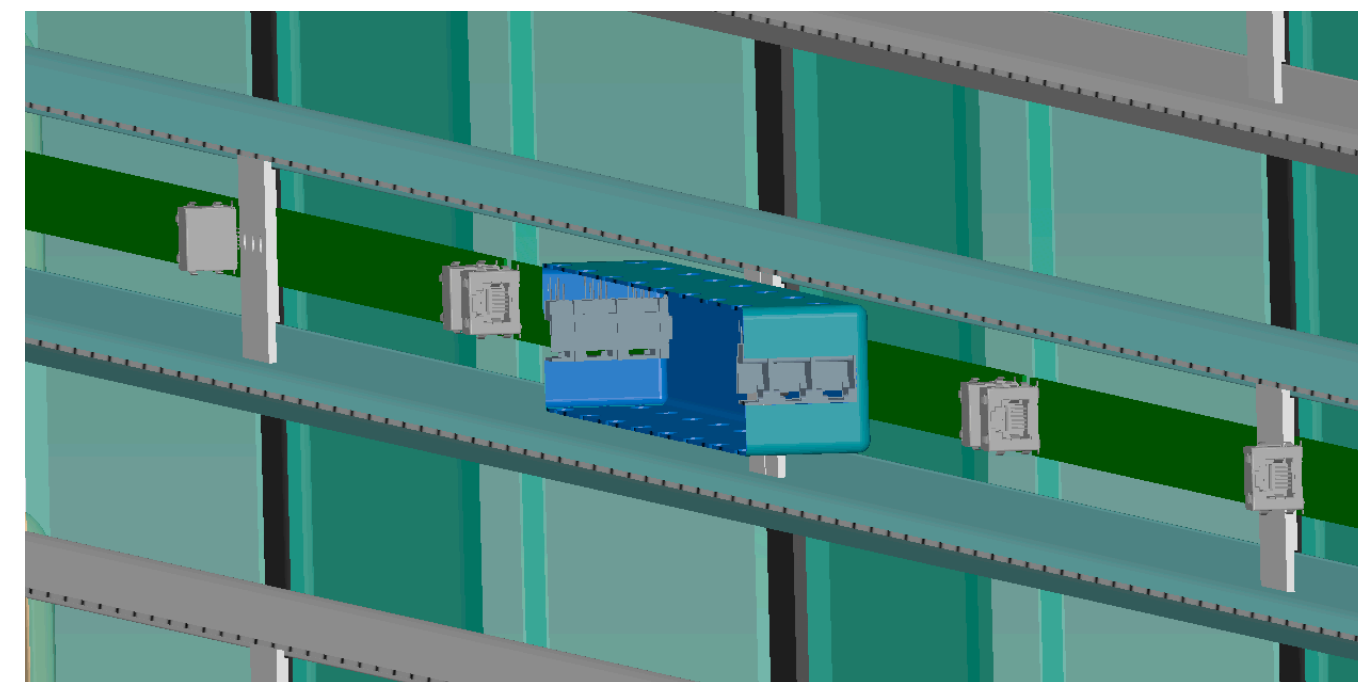
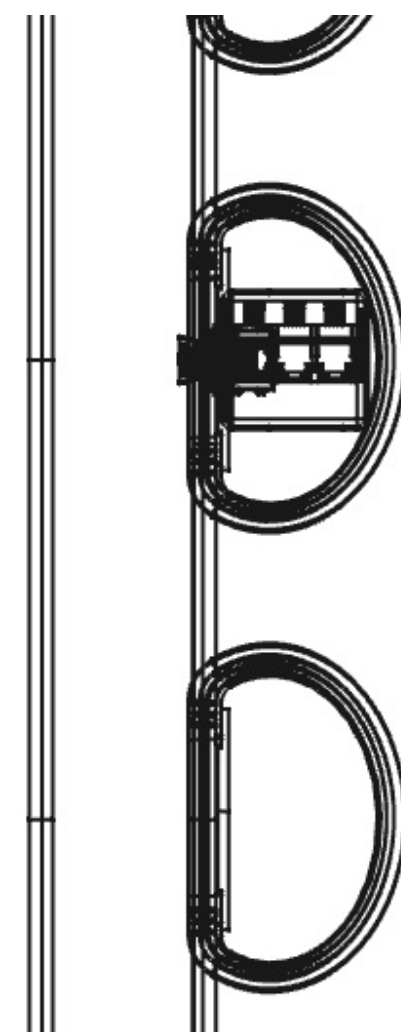

SiPMs, electronics boards, and instrumentation housed inside Al profile (shielding and discharge protection)

Side view

# View in DUNE VD-like LArTPC

3 m x 3.2 m module

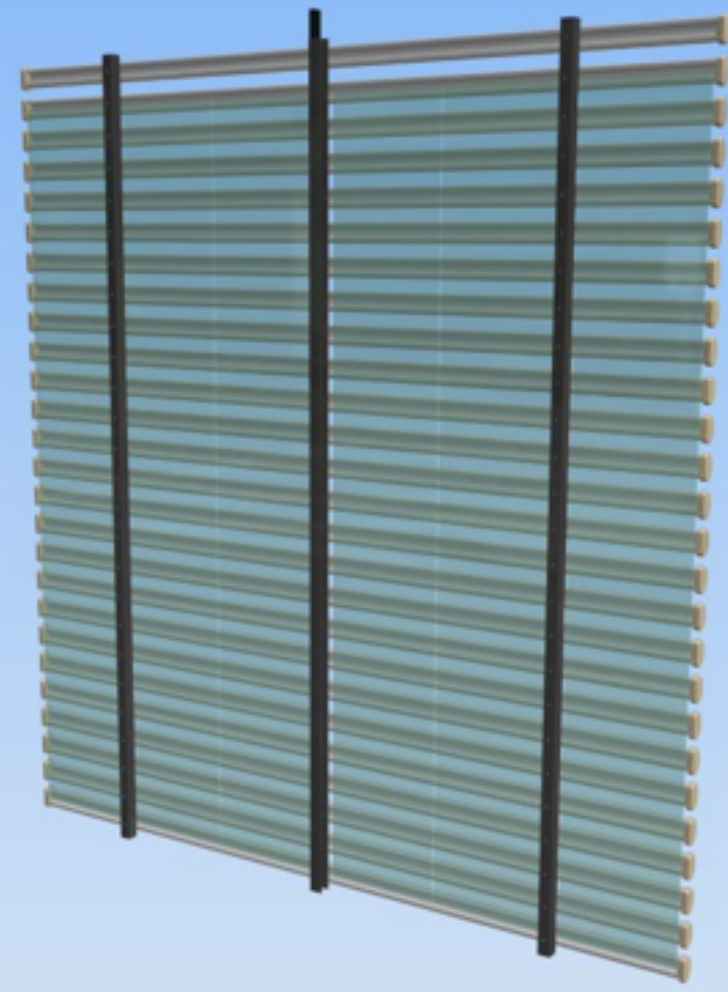

4 modules/column

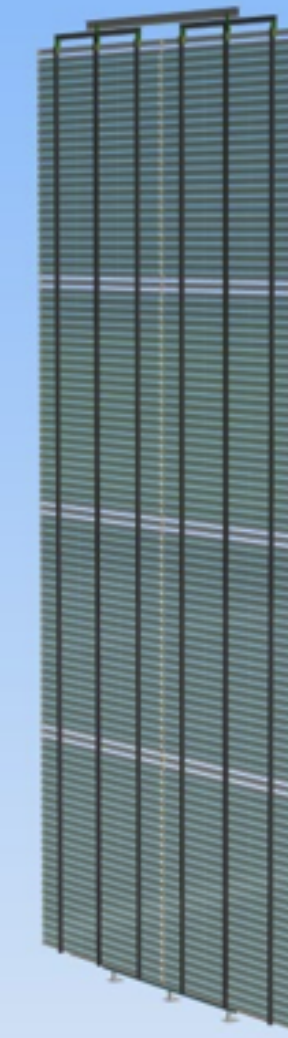

Interior view

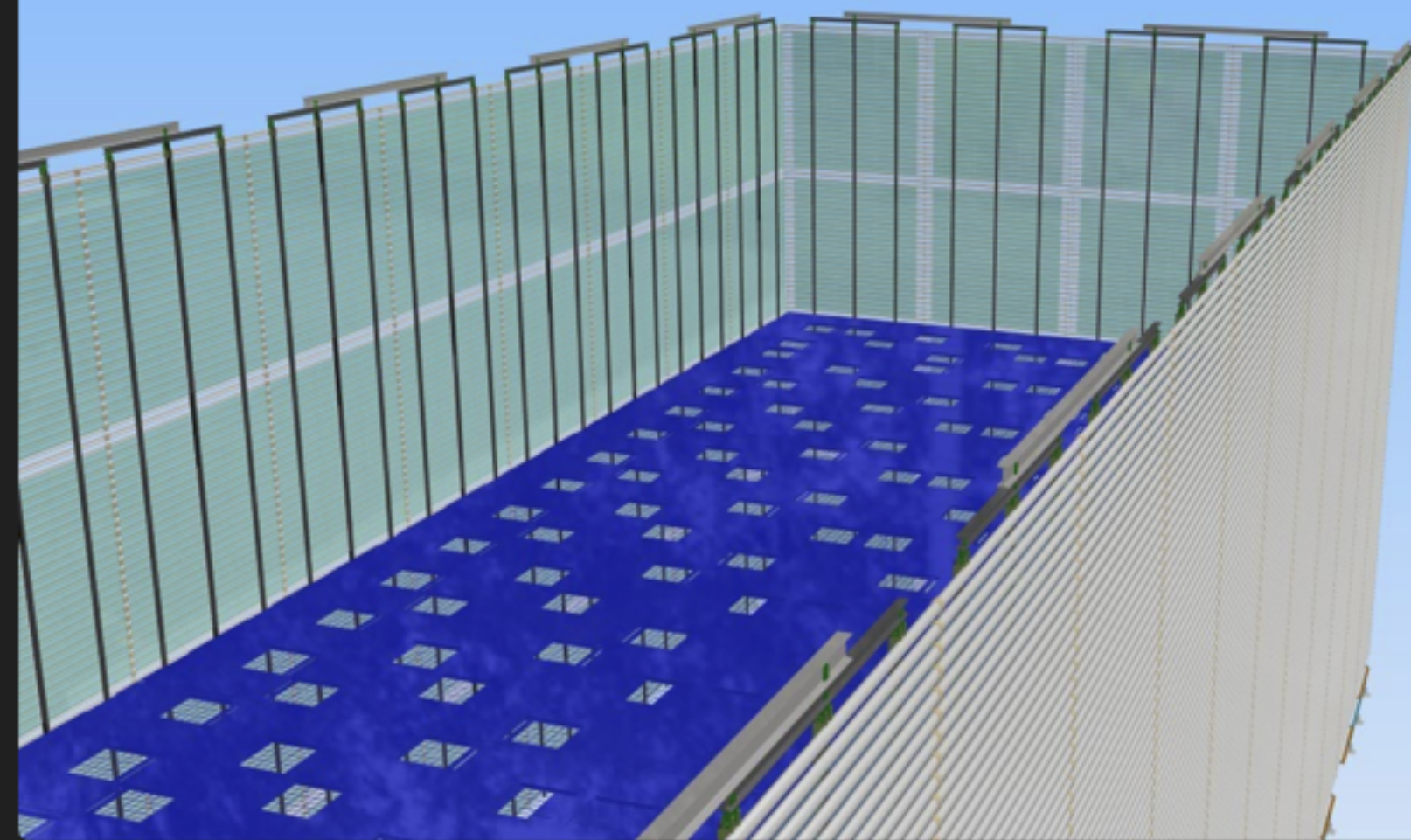

Bird's-eye view

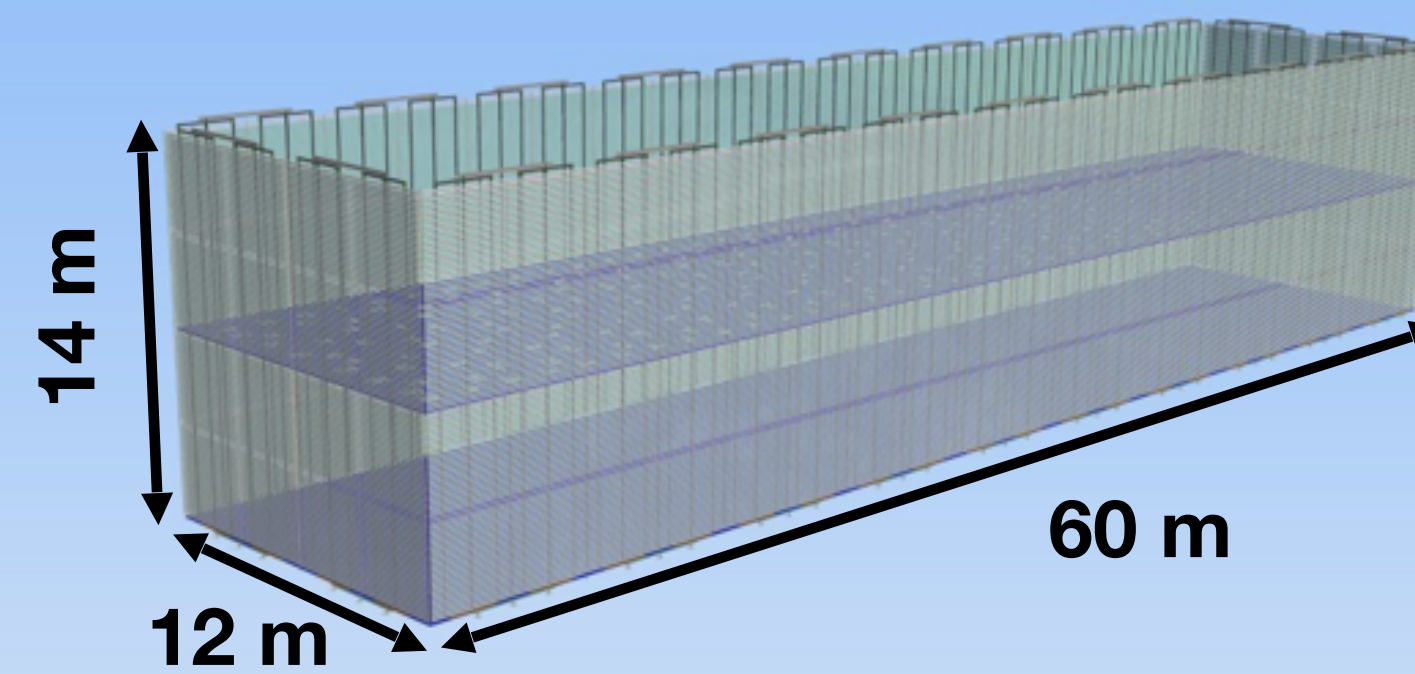

# APEX Module Readout Concept with PoF and SoF

- LV PoF for powering cold readout electronics
- Each row of 6 PD modules share HV PoF to bias all SiPMs, share ADC to single SoF fiber

