



The search for CLFV with the Mu2e Experiment

Kevin Lynch, AD/TSD and Mu2e
US/JP Target Collaboration Meeting
19 February 2024

There are many potential signatures of CLFV physics in the muon sector

Surface muon beams

$$\mu^+ \rightarrow e^+ \gamma$$

$$\mu^+ \rightarrow e^+ e^+ e^-$$

$$\mu^+ e^- \leftrightarrow \mu^- e^+$$

Double CLFV!

“High” energy beams

$$\mu^- A(Z, N) \rightarrow e^- A(Z, N)$$

$$\mu^- A(Z, N) \rightarrow e^+ A(Z - 2, N)$$

CLFV and LNV!

There are a large number of experiments proposed to further address these channels; I apologize for only mentioning those I'm involved with.

Our key advantage: conversion is kinematically distinct from the background muon decay spectrum

Our key advantage: conversion is kinematically distinct from the background muon decay spectrum

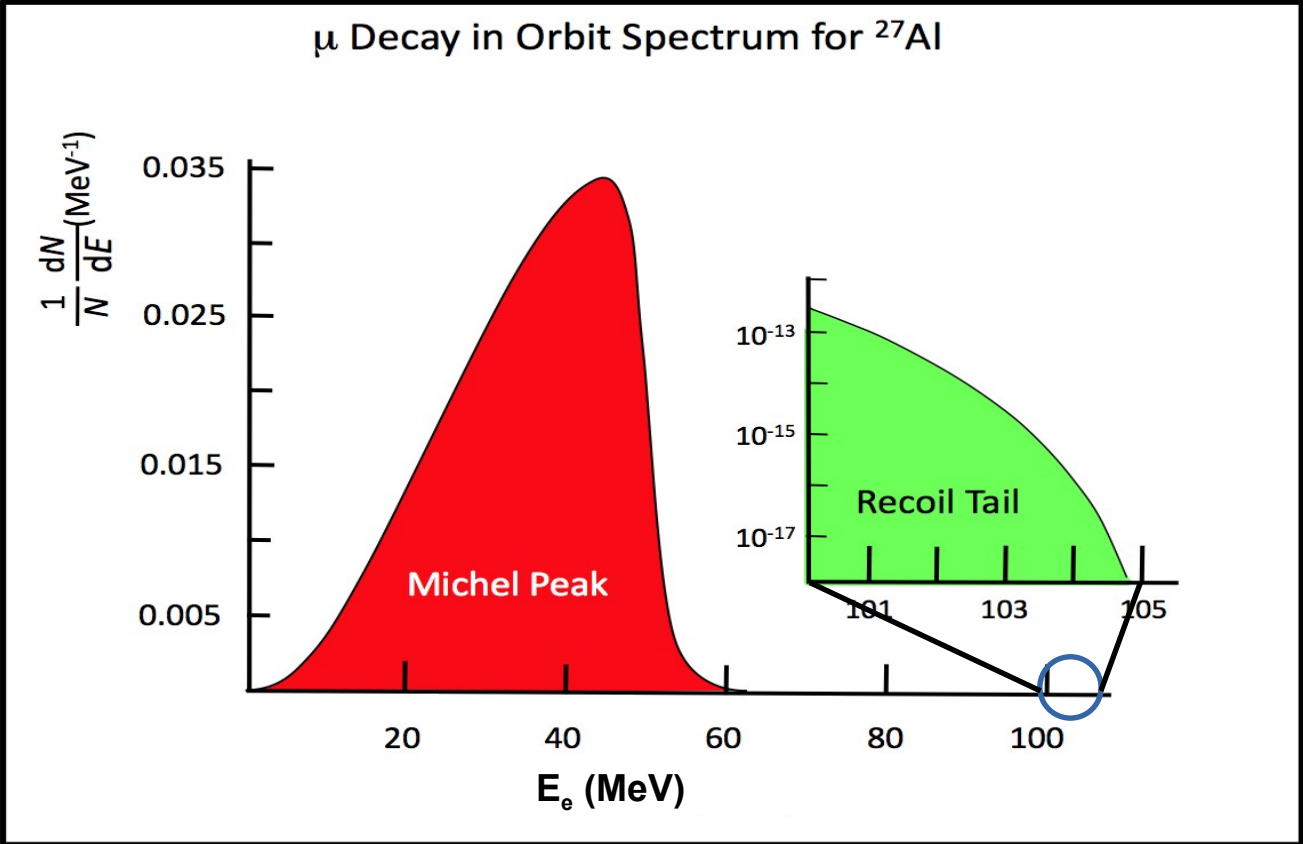

Our key advantage: conversion is kinematically distinct from the background muon decay spectrum

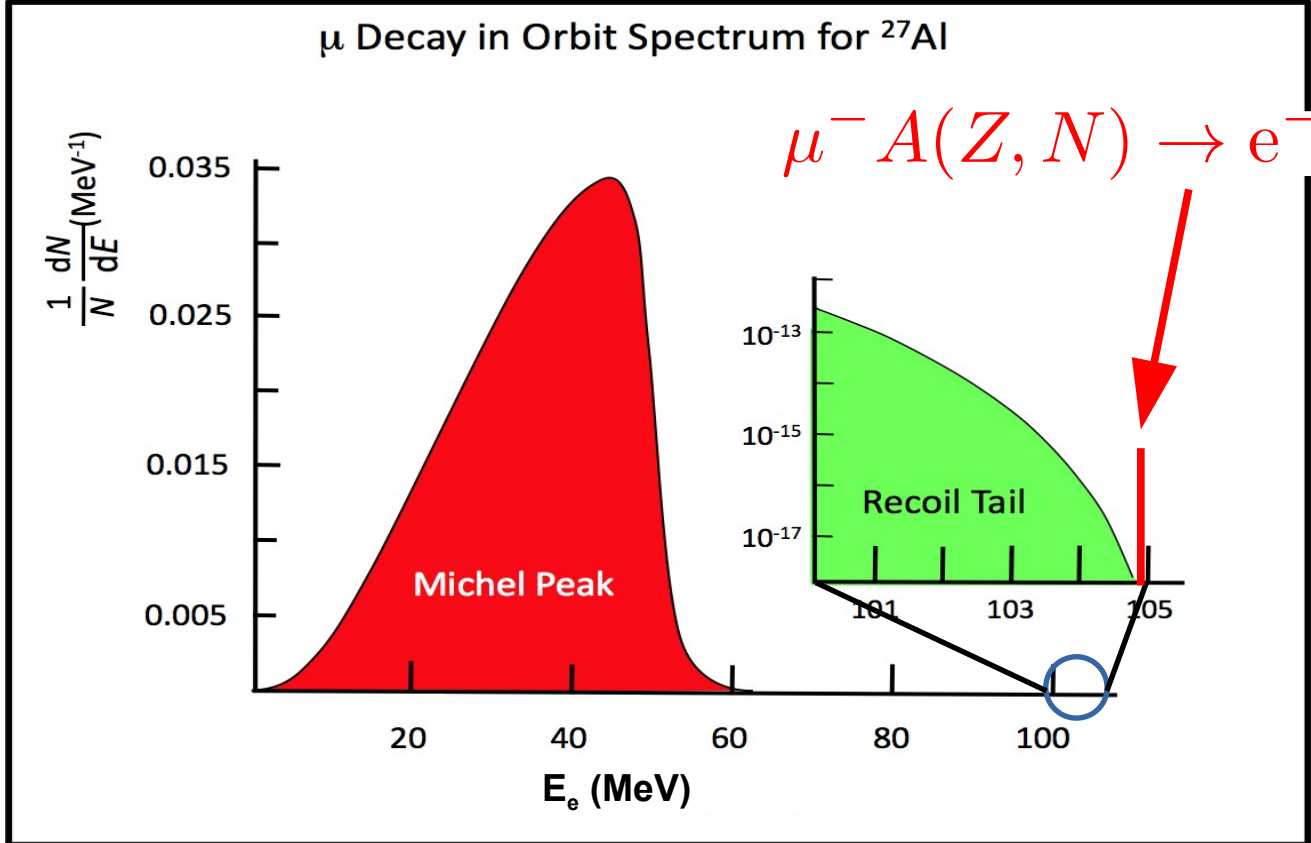

Our key advantage: conversion is kinematically distinct from the background muon decay spectrum

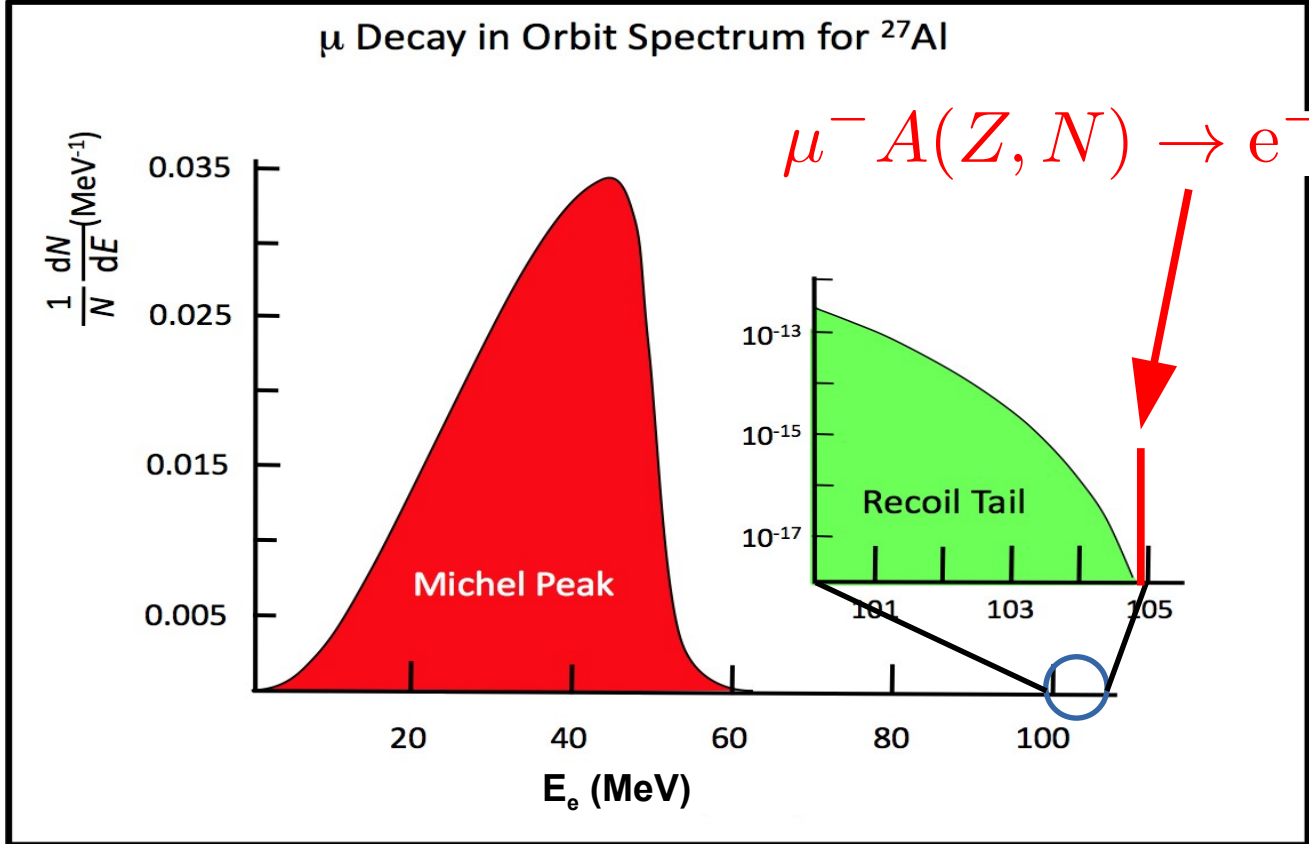

Our signal is a mono-energetic electron at 105 MeV, above the background tail!

Beam induced backgrounds can be reduced by using a pulsed beam source ... which we can generate at Fermilab

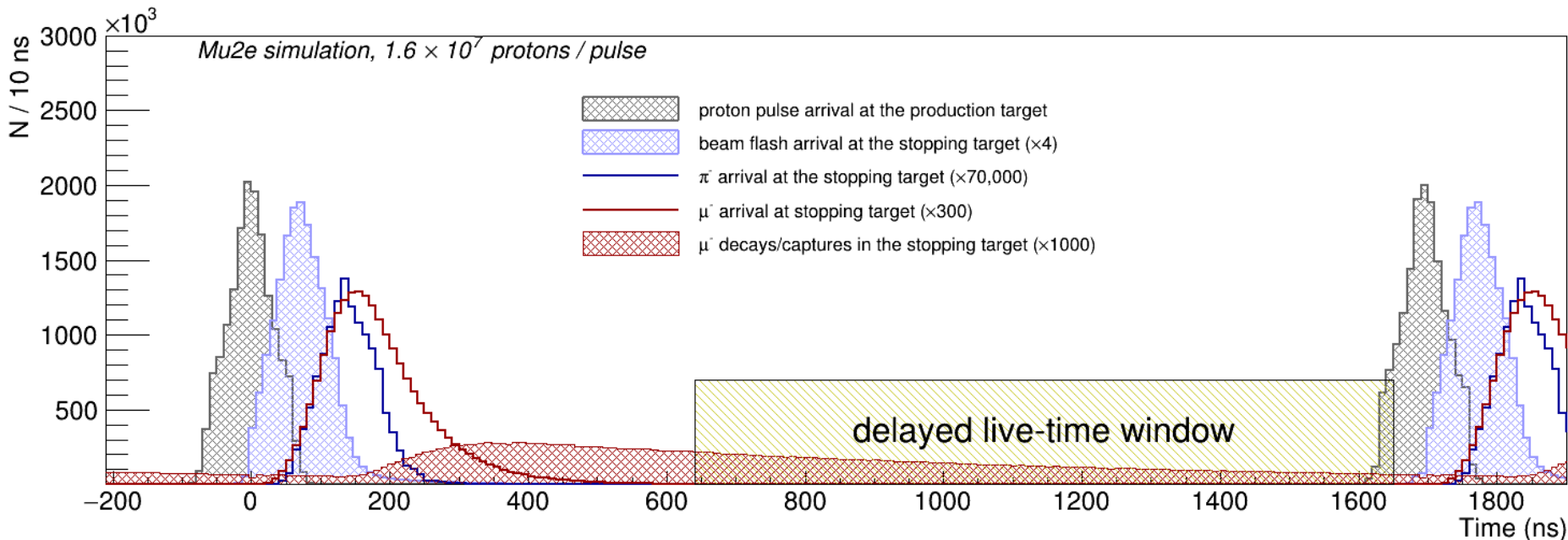

Let's first explore how Mu2e will tackle this challenge

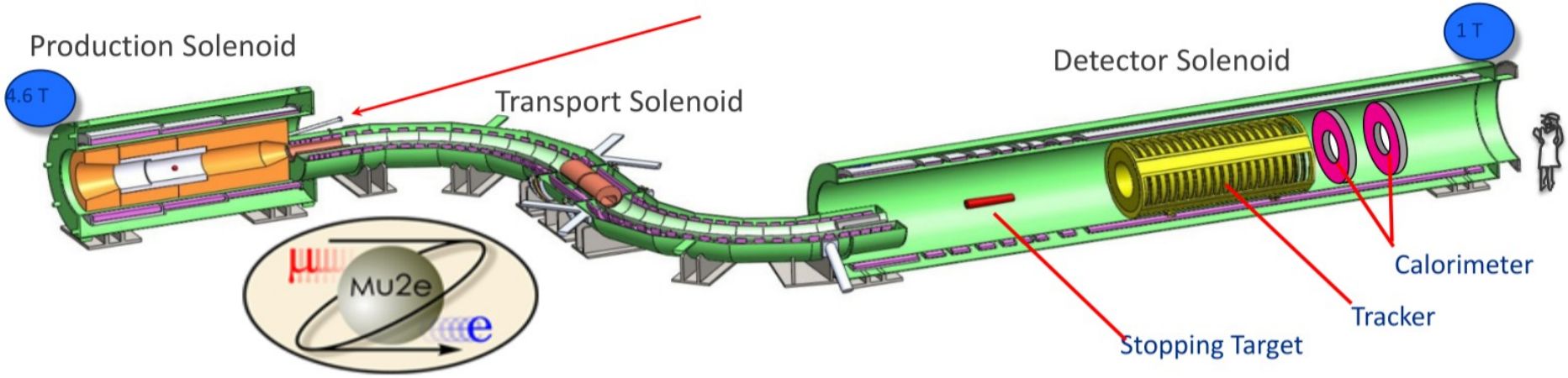

Where do our protons come from? Keep this constraint in mind:

Where do our protons come from? Keep this constraint in mind:

Since the end of Tevatron running, *neutrino physics* has driven the proton economics at Fermilab, and that *will* remain the key driver for the next 30+ years!

Cartoon of the current accelerator complex

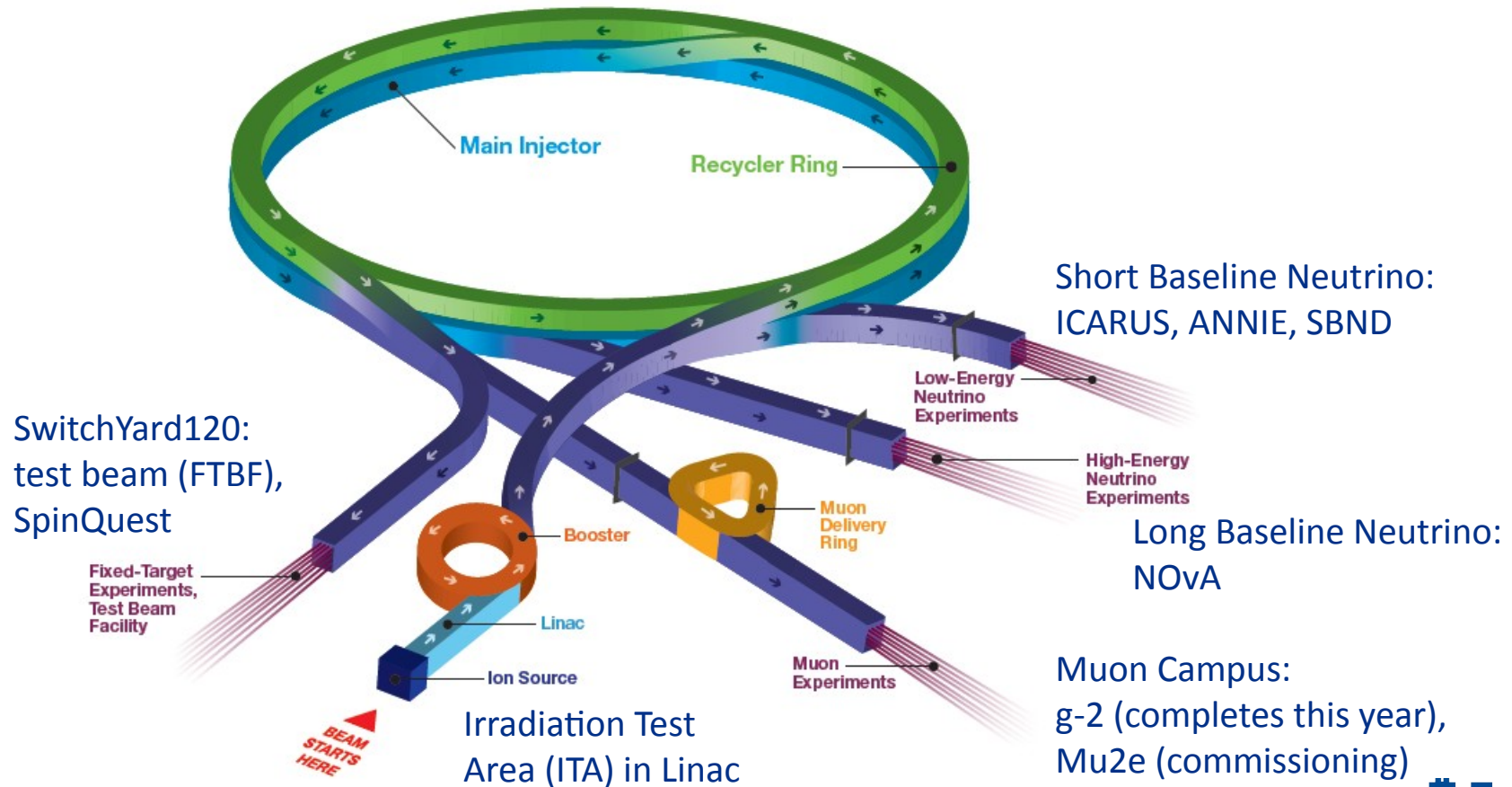

Cartoon of the current accelerator complex

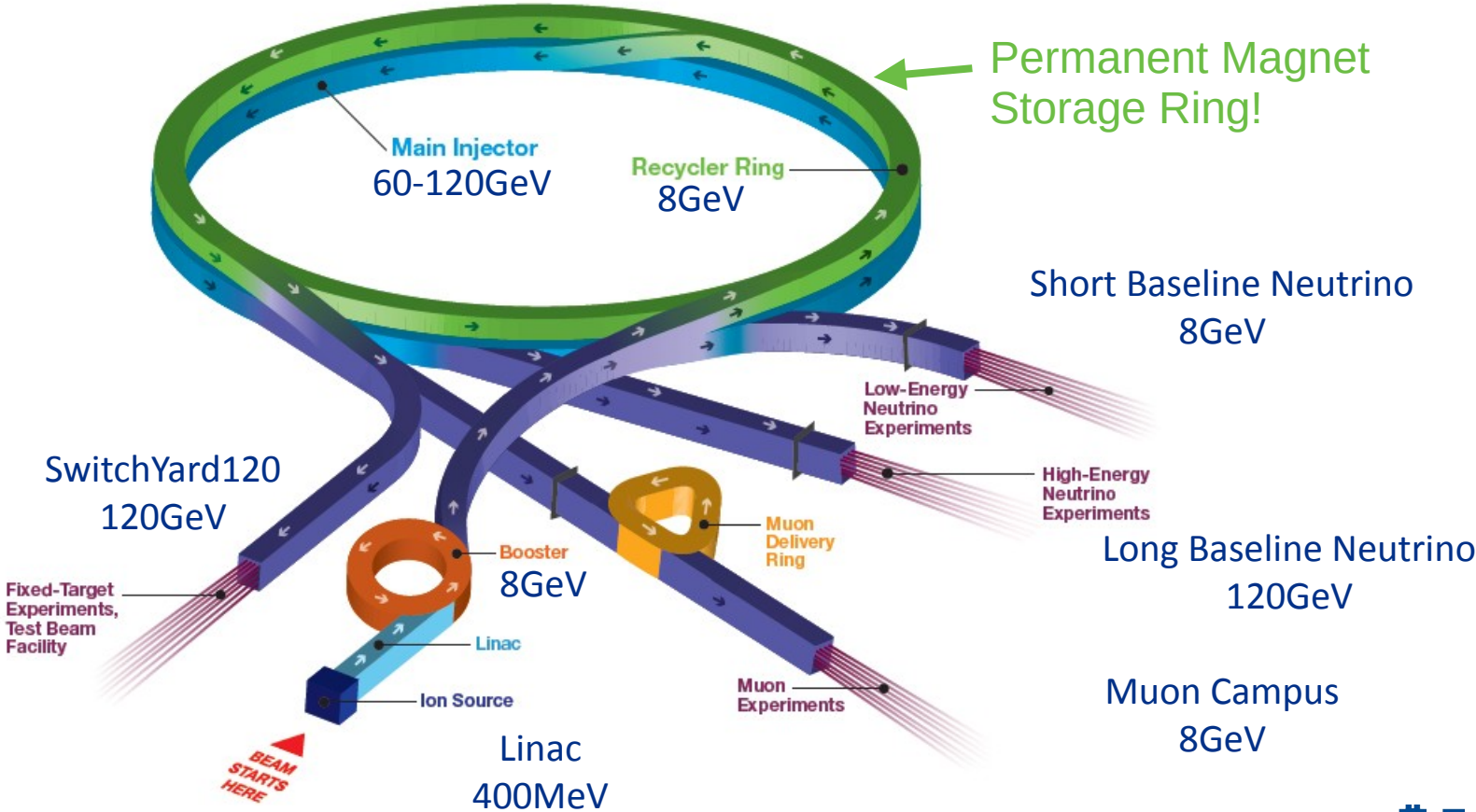

Reminder that these cartoons hide a wealth of complex and interesting science and engineering

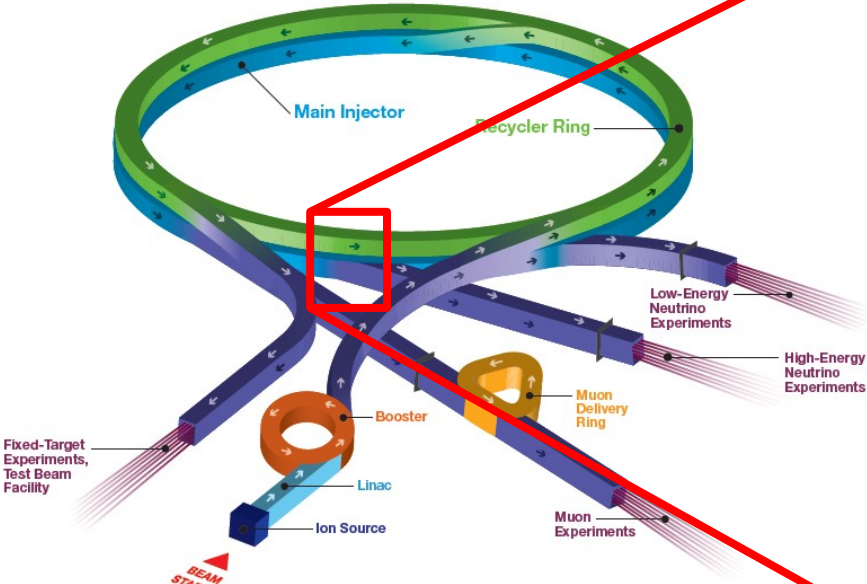

They also hide a vast hierarchy of scales!

- Linac (400MeV)
- Booster (8GeV)
- RR/MI (8GeV/120GeV)
- Muon Campus (3.094GeV/8GeV)
- BNB (8GeV)
- NuMI (120GeV)

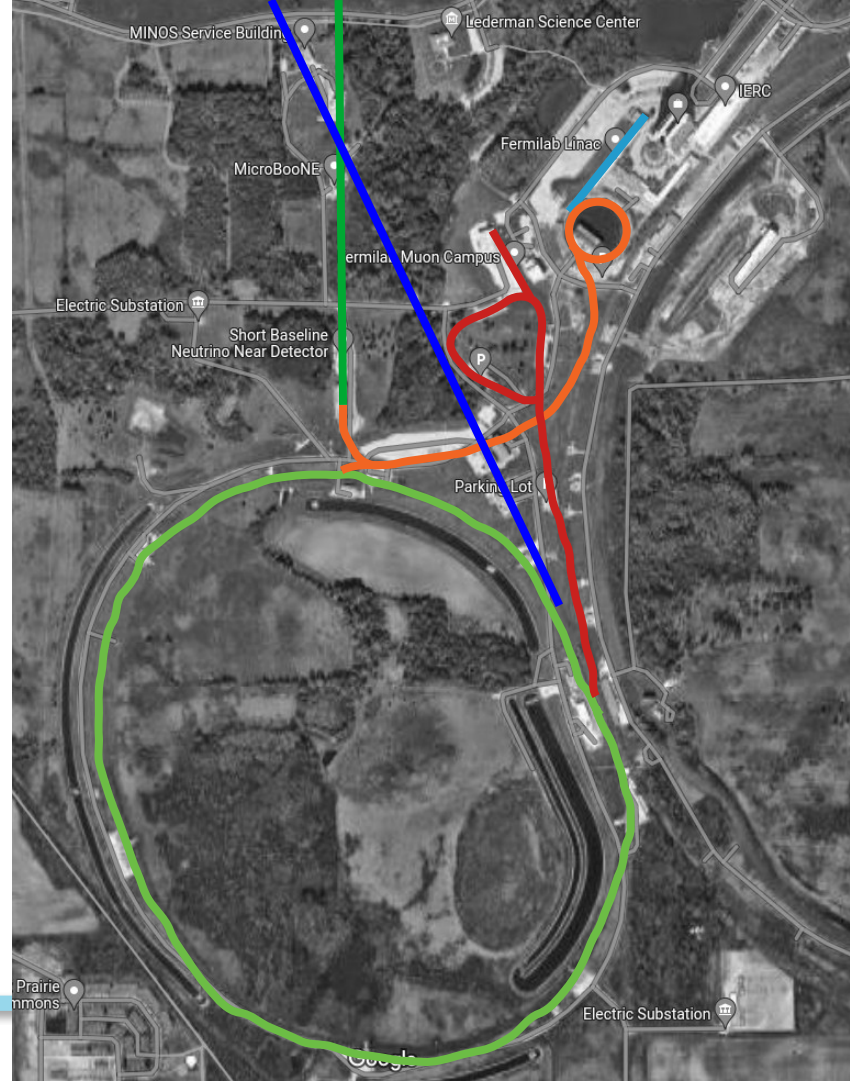

The accelerator timeline is organized around the NuMI program

- H⁻ linac (1970, 1993, 2012)
 - 400 MeV linac ~20mA
- Booster synchrotron (1970)
 - H⁻ stripping injection (1978)
 - 16 turns to $\sim 4.7 \times 10^{12}$ p per pulse
 - **Resonant Ramp from 0.4 to 8 GeV at 15 Hz**
- Recycler (1998)
 - 3.3 km permanent magnet 8 GeV ring
 - Slip-stacking 12 Booster batches, $\sim 56 \times 10^{12}$ p
 - Also re-bunches beam for Muon Campus
- Main Injector (1998, but!)
 - 8 to 120 GeV ramp, cycle time 1.133*-1.4 s

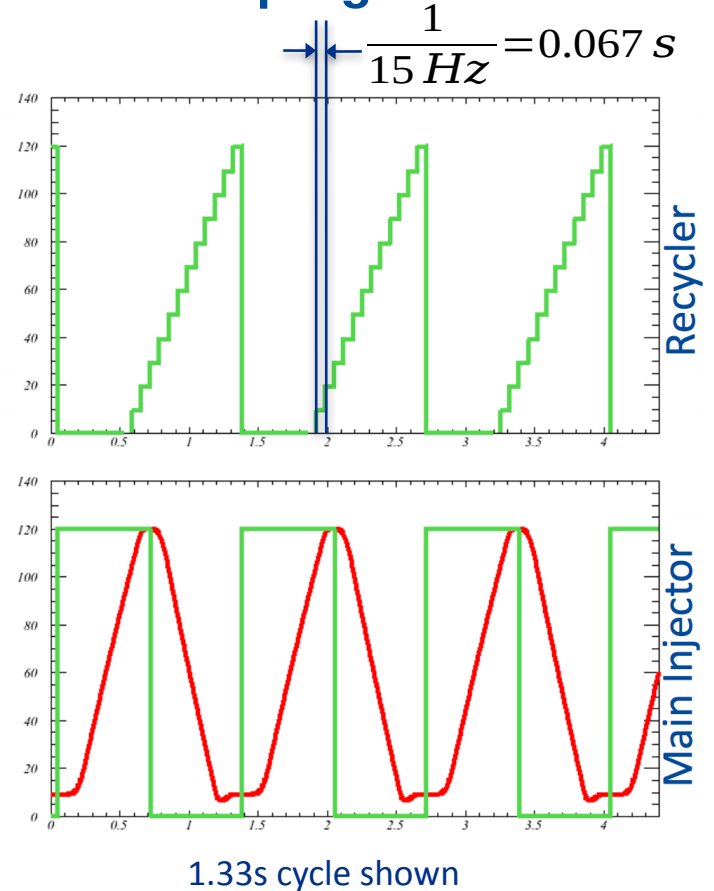

Stacking beam in the Recycler is the key timeline constraint

- Slip stacking is a method of injecting multiple beams at different momenta into the same circular machine.
 - We combine slip stacking with boxcar stacking to stuff beam into the Recycler

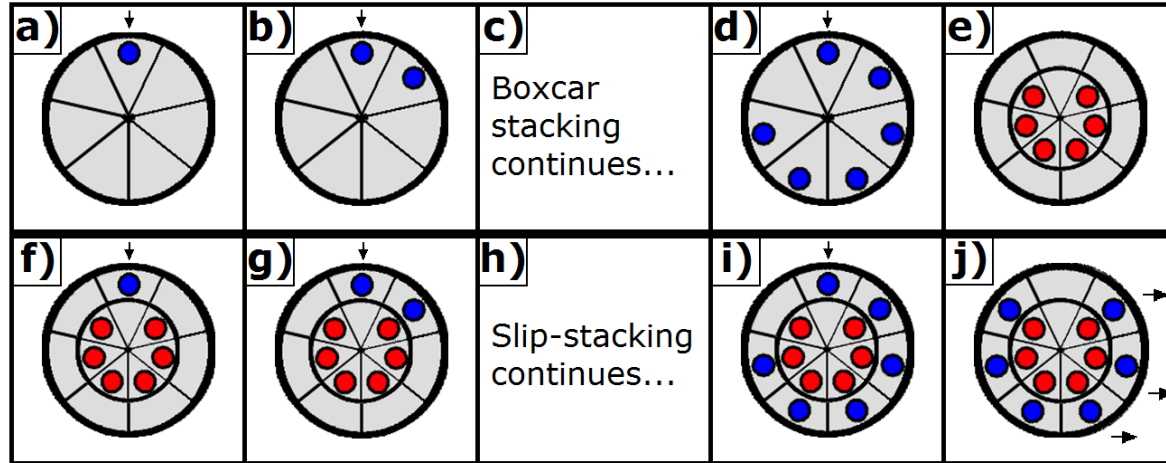

7x as many
53MHz RF
buckets in RR/MI
as in Booster
(588/84) ... 81
filled buckets per
transfer

- These manipulations require 13 ticks of the Booster clock
 - 12 for injection, one for extraction

We want to take those spare protons and move them to Mu2e

- Each Booster batch is rebunched from $81 \times 53\text{MHz}$ to $4 \times 2.5\text{MHz}$
- The rebunched beam pulses are extracted one at a time from the RR
- These pulses are injected into the 2.36MHz DR
- Those protons are then slowly extracted to the experiment



We want to take those spare protons and move them to Mu2e

- Each Booster batch is rebunched from $81 \times 53\text{MHz}$ to $4 \times 2.5\text{MHz}$
- The rebunched beam pulses are extracted one at a time from the RR
- These pulses are injected into the 2.36MHz DR
- Those protons are then slowly extracted to the experiment

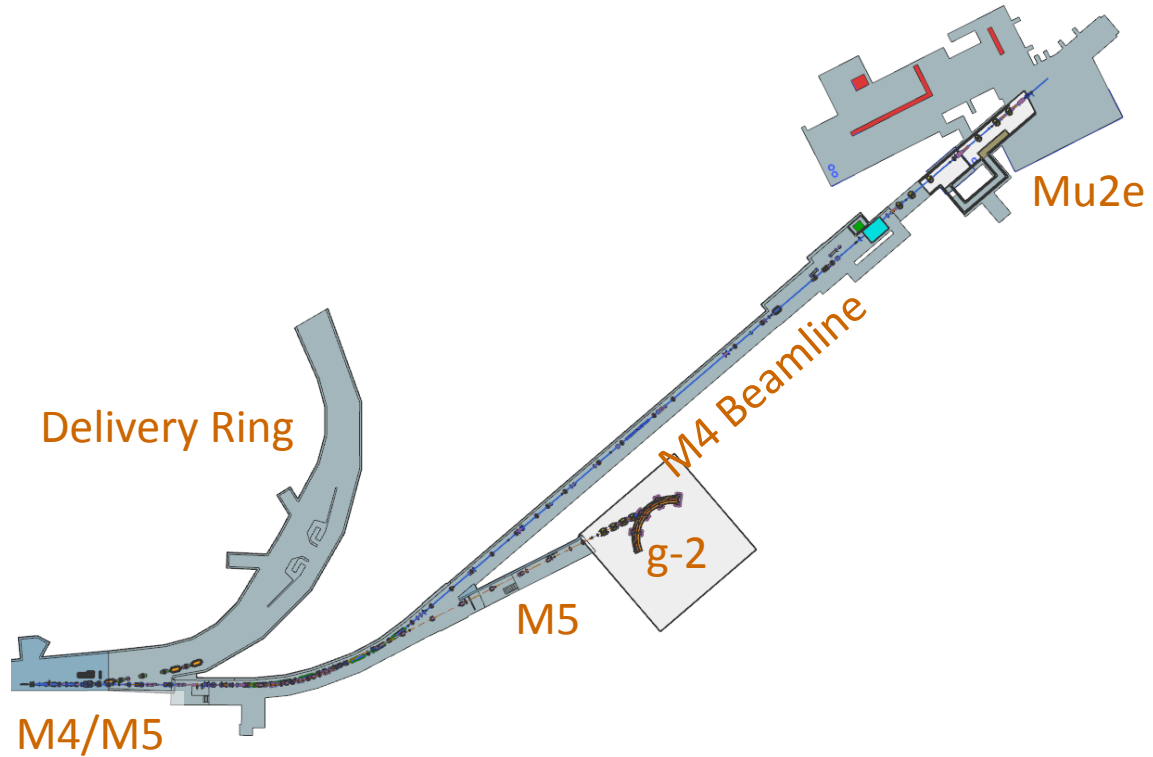

We want to take those spare protons and move them to Mu2e

- Each Booster batch is rebunched from $81 \times 53\text{MHz}$ to $4 \times 2.5\text{MHz}$
- The rebunched beam pulses are extracted one at a time from the RR
- These pulses are injected into the 2.36MHz DR
- Those protons are then slowly extracted to the experiment



M4/M5

All our machine timelines are built around moving 12 successive Booster batches to the MI – how does this impact muons?

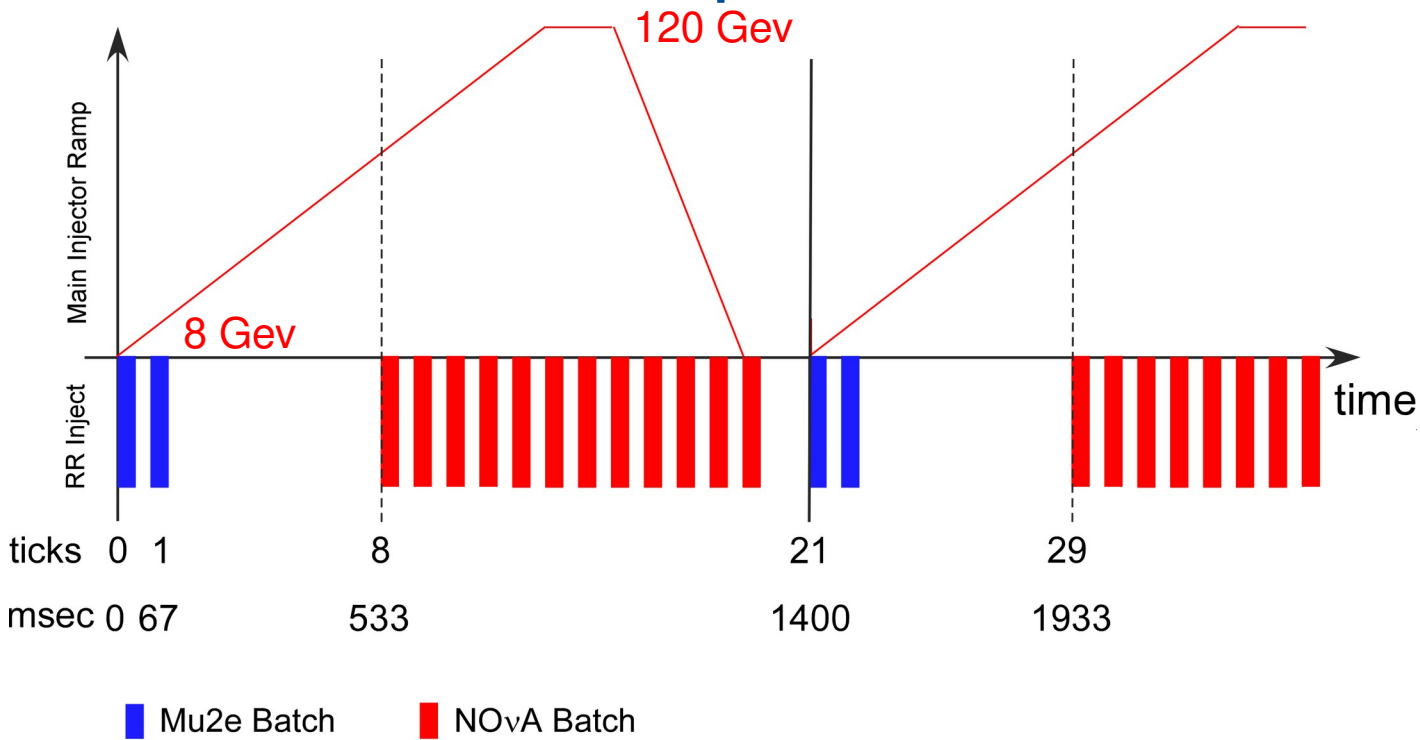

1 tick = 1/15 sec

All our machine timelines are built around moving 12 successive Booster batches to the MI – how does this impact muons?

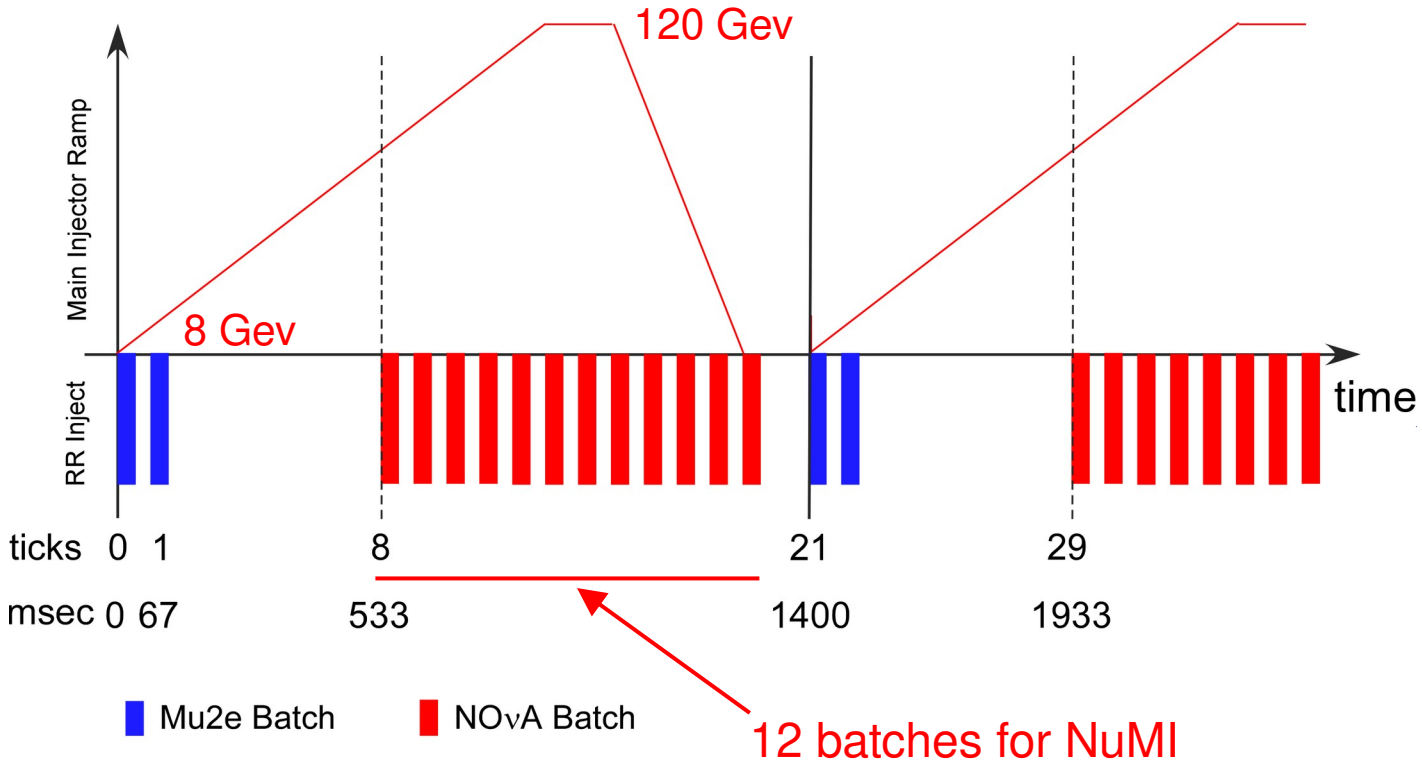

1 tick = 1/15 sec

All our machine timelines are built around moving 12 successive Booster batches to the MI – how does this impact muons?

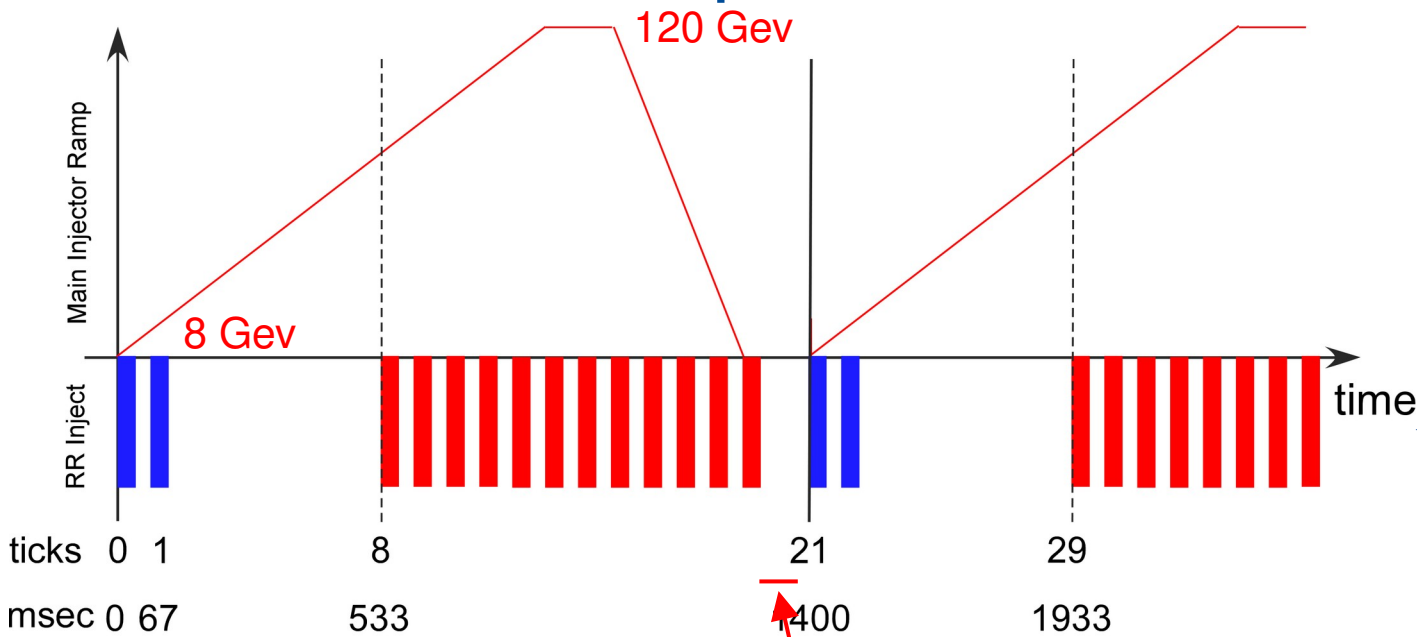

■ Mu2e Batch

■ NOvA Batch

1 tick = 1/15 sec

One tick for RR → MI transfer

All our machine timelines are built around moving 12 successive Booster batches to the MI – how does this impact muons?

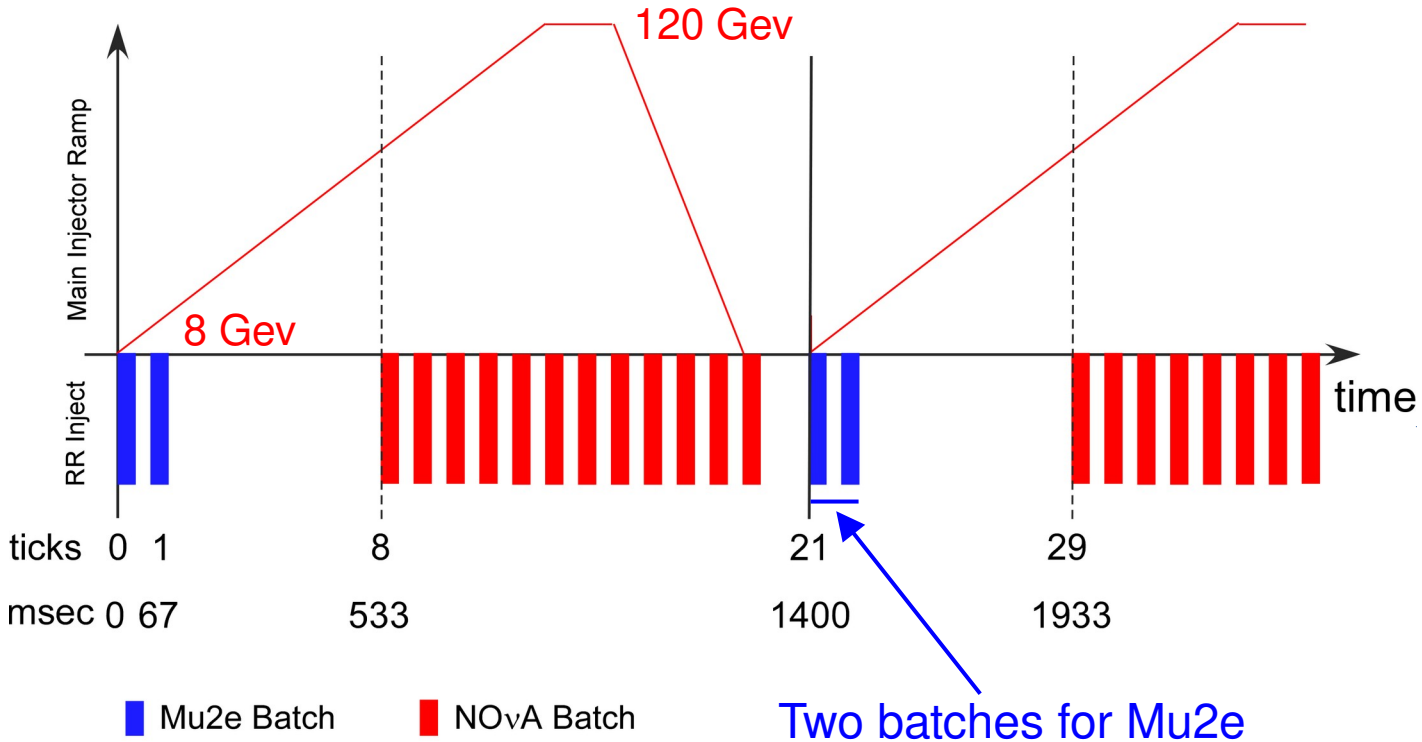

1 tick = 1/15 sec

All our machine timelines are built around moving 12 successive Booster batches to the MI – how does this impact muons?

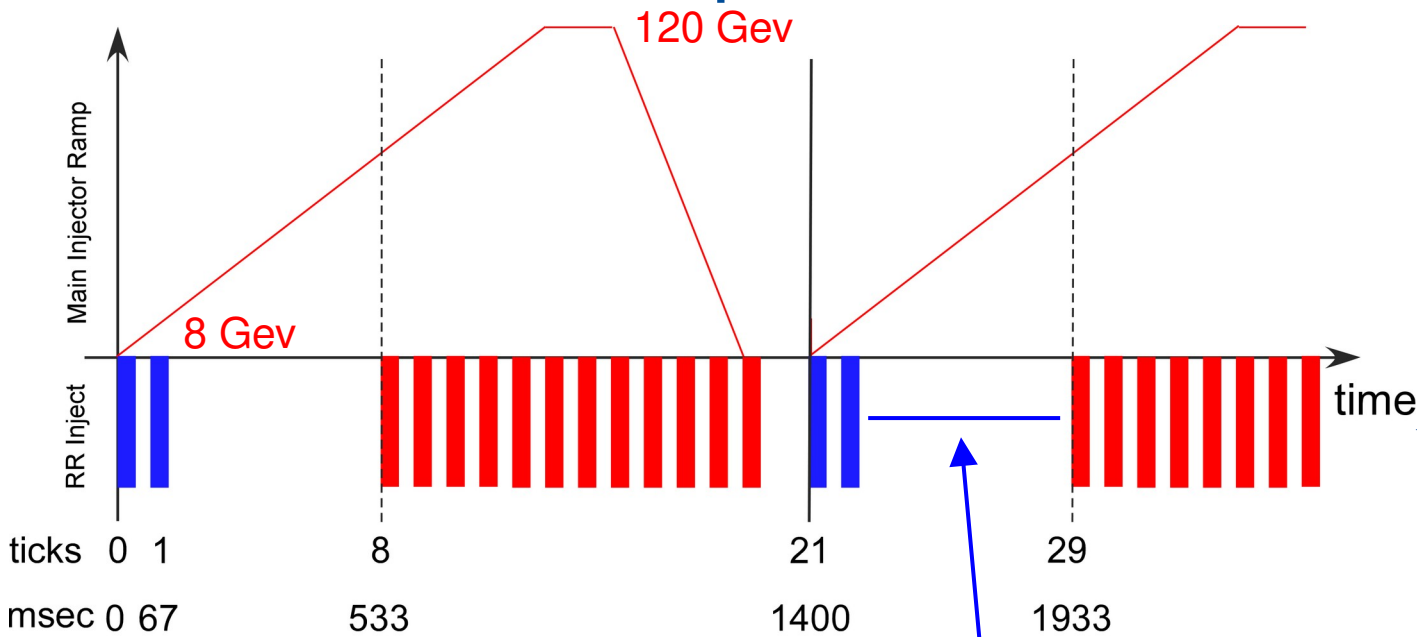

Mu2e Batch

NOvA Batch

1 tick = 1/15 sec

Rebunching and transfer to DR
81x2 53MHz → 1x8 2.5MHz

Beam to Mu2e is resonantly extracted from the DR over 8 ticks

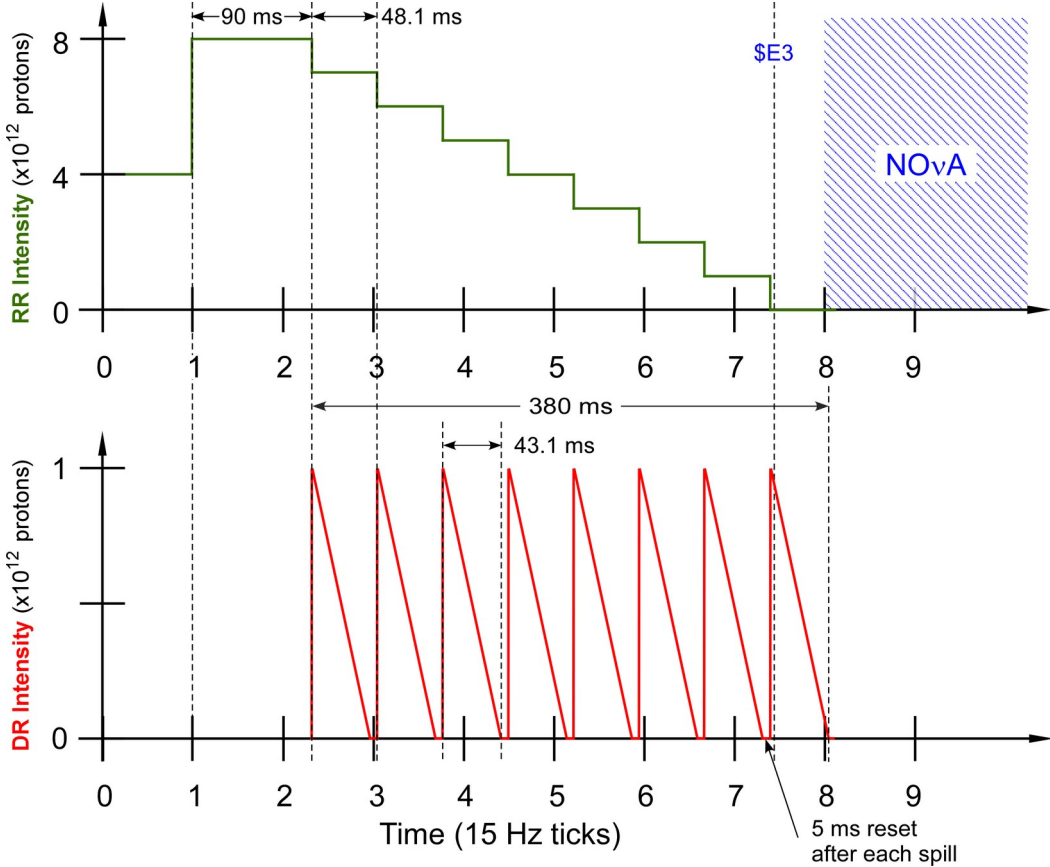

Beam to Mu2e is resonantly extracted from the DR over 8 ticks

Two batches from Booster

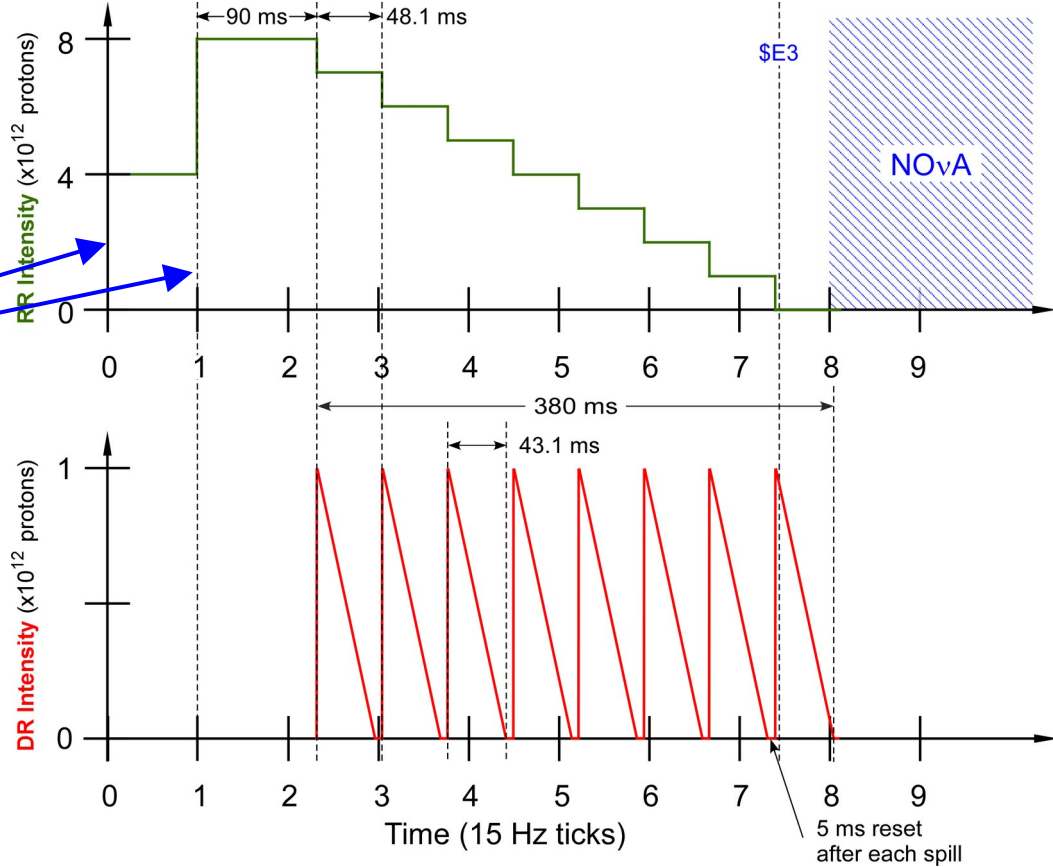

Beam to Mu2e is resonantly extracted from the DR over 8 ticks

Rebatching takes >1 15Hz tick!!!

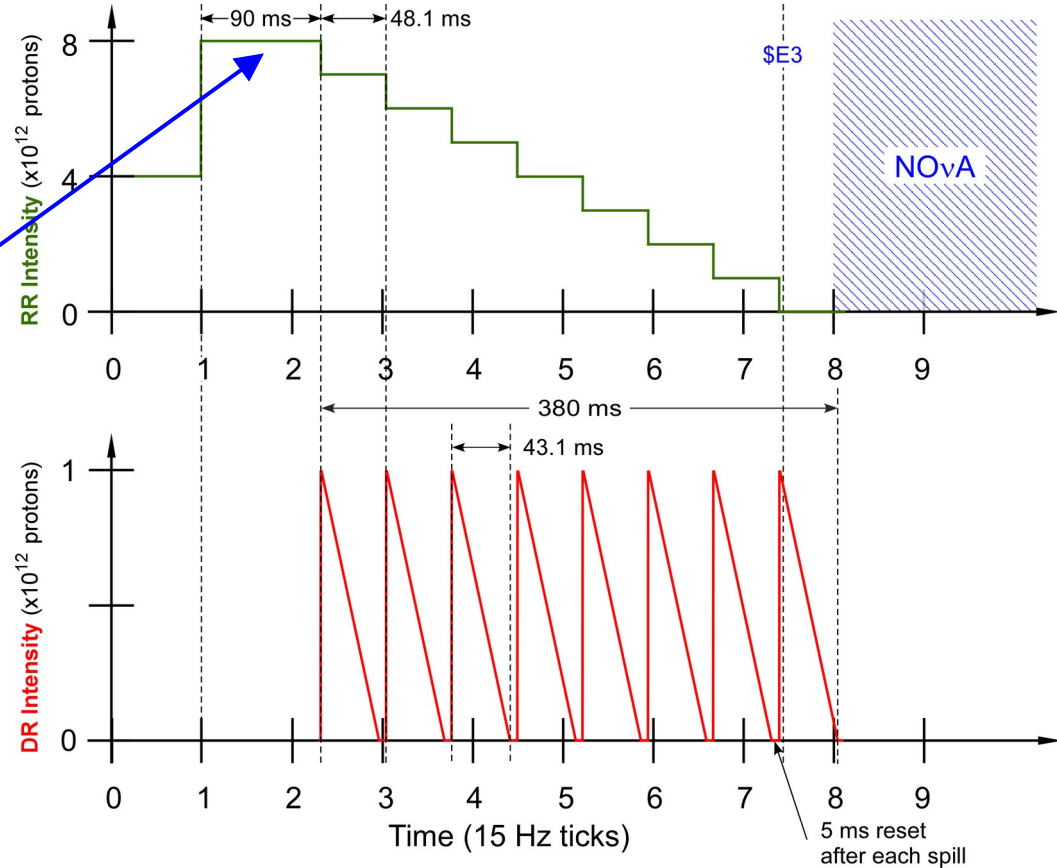

Beam to Mu2e is resonantly extracted from the DR over 8 ticks

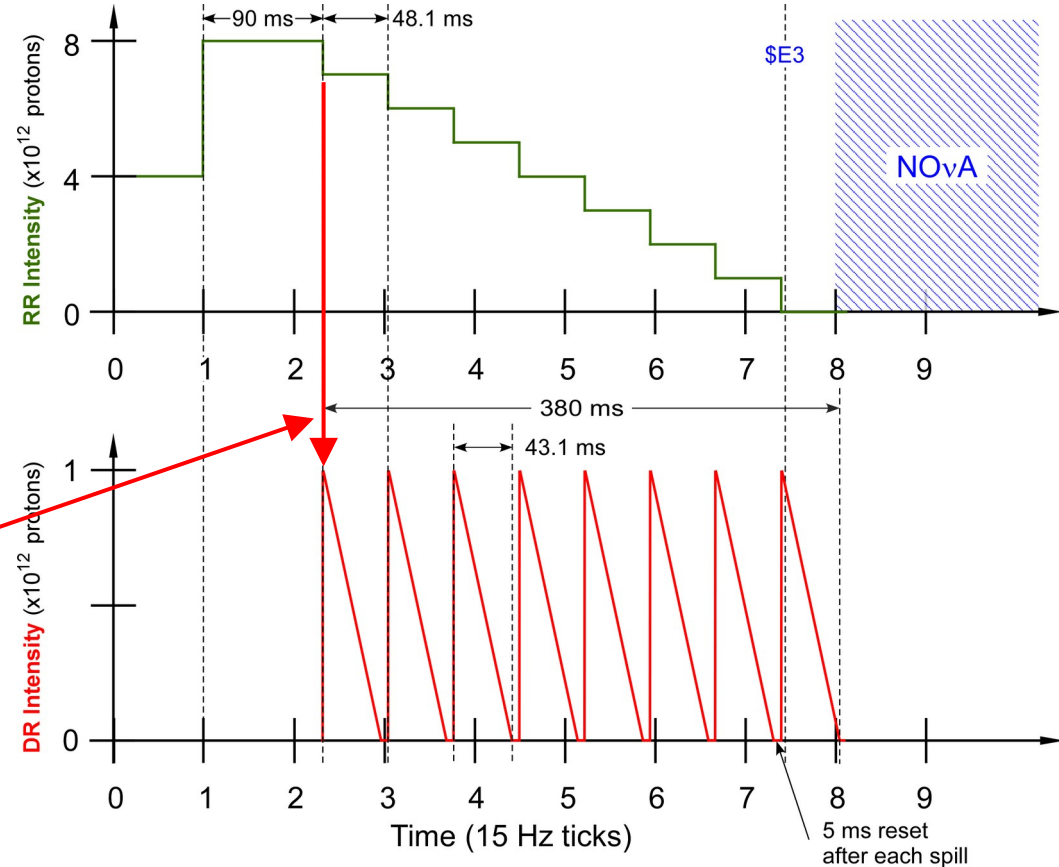

Move one of the new batches to DR
2.5MHz \rightarrow 2.36MHz!

Beam to Mu2e is resonantly extracted from the DR over 8 ticks

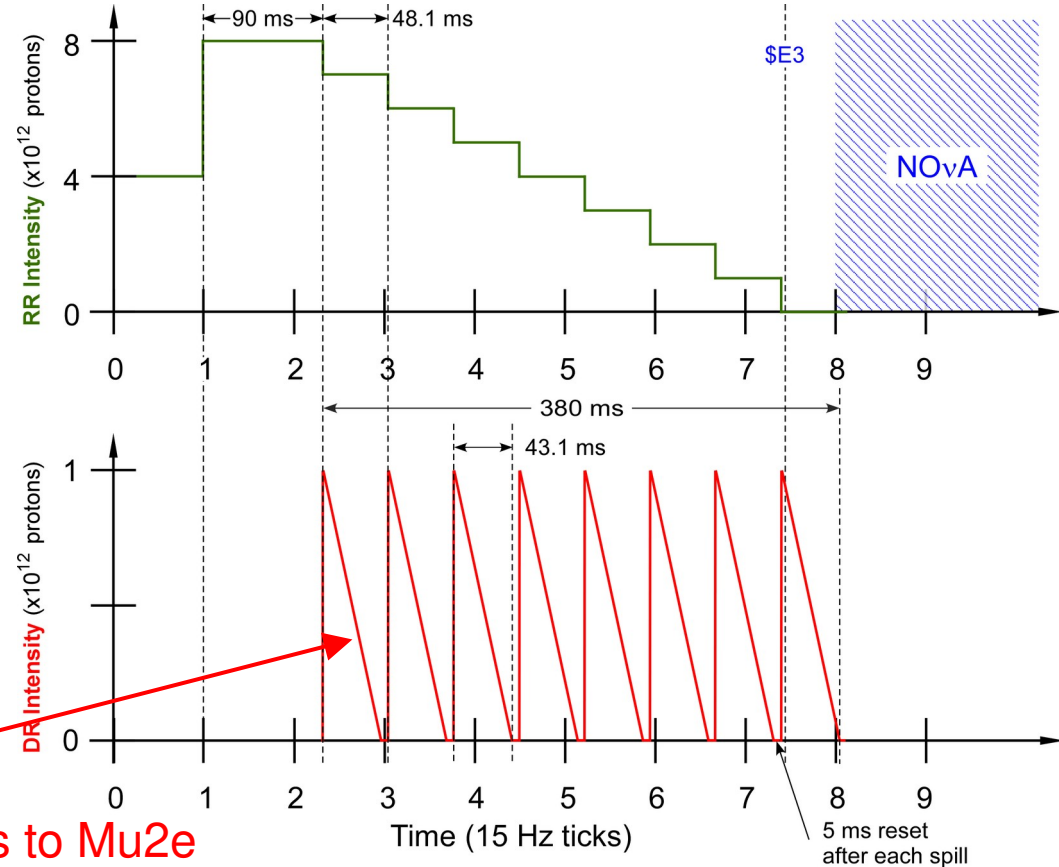

Resonant extraction ~25-30k pulses to Mu2e

Mu2e resonantly extracts from the delivery ring

- Quadrupoles intentionally drive a $1/3$ integer resonance in the horizontal tune.
- Sextupoles induce a controlled beam instability.
- Septum foils peel off a bunch each turn.
- Dynamic spill regulation control is accomplished by tune corrections and RFKO.
- Full extraction occurs over $\sim 25\text{-}30\text{k}$ turns.
- Remaining beam is dumped, and the cycle starts again.

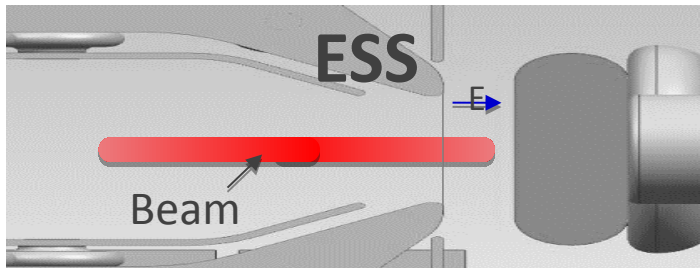
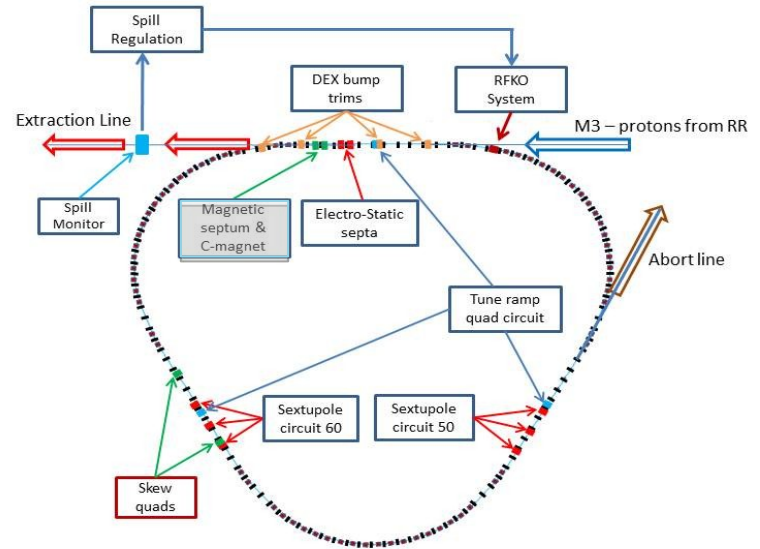

The delivery ring orbital period – 1695ns – drives the interpulse spacing in Mu2e, and is a nearly ideal match to the muonic aluminum lifetime of 864ns .

Twenty slides ago, I showed you this picture

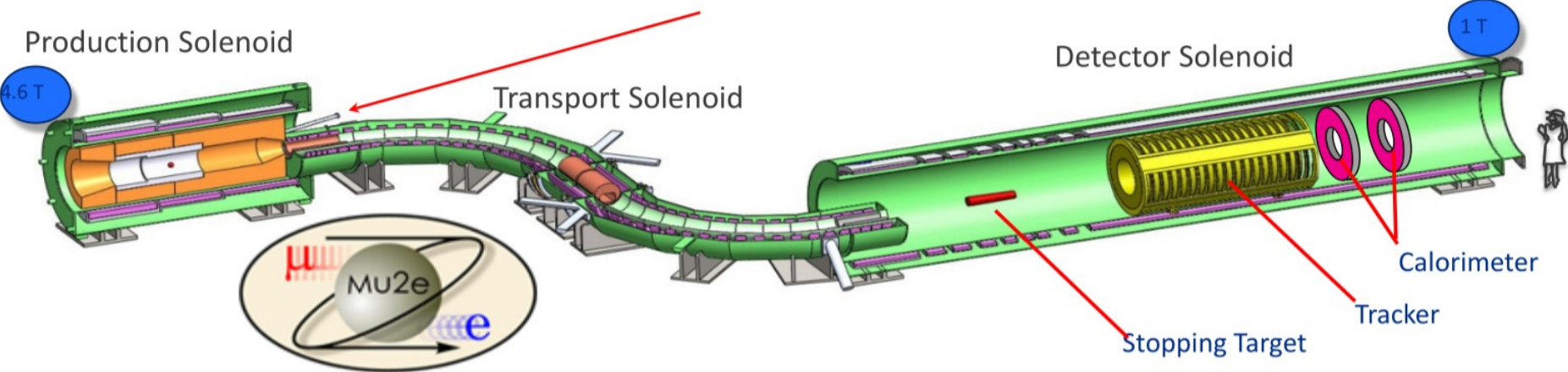

The production target is mounted inside a high field Production Solenoid, and we capture and transport backward muons

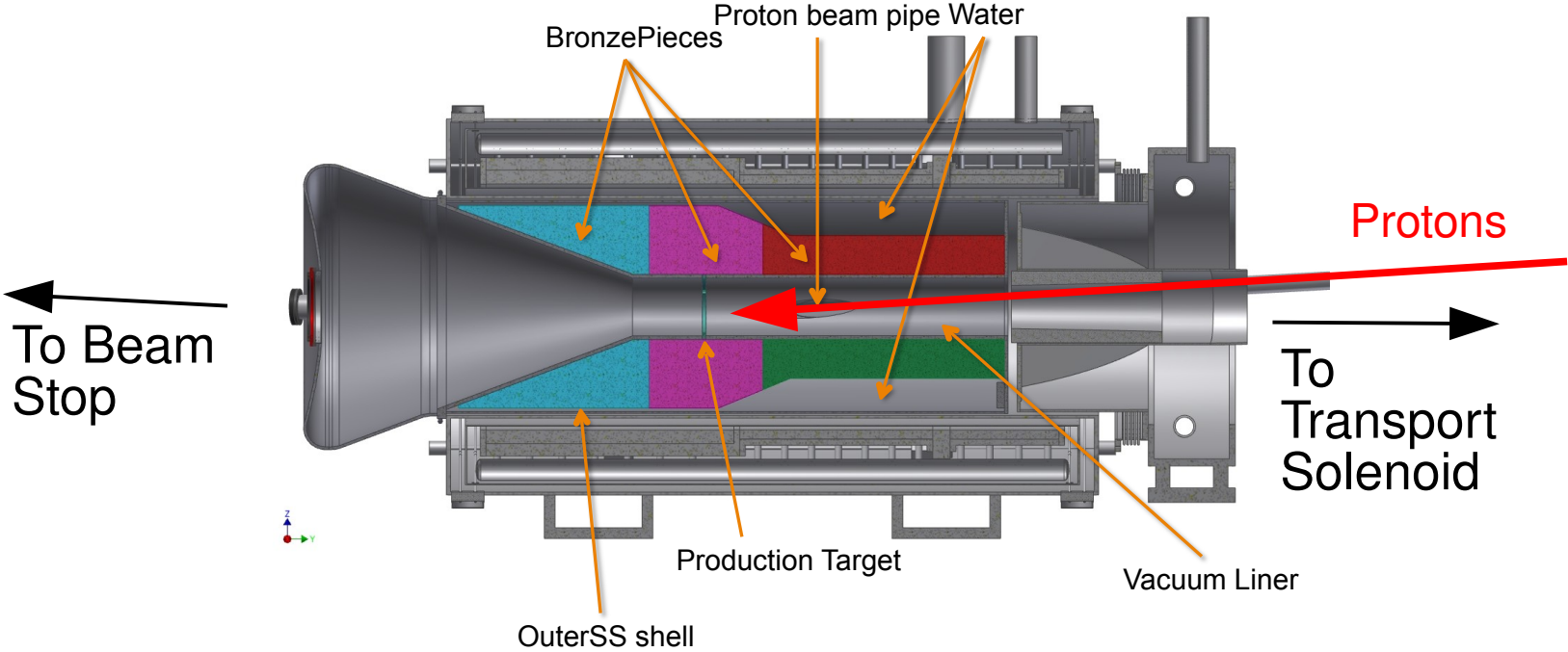

The production target is a radiatively cooled tungsten structure

- Bicycle wheel support
- LaO₂-doped Tungsten, core is EDMed from single rod
- Longitudinally segmented cylinder (**stress management**):
 - 3.15 mm radius, 160+60 mm length
- Longitudinal fins (**structure and thermal management**)
- 1mm tungsten spokes
- ~ 700 W power absorption
- ~ 1500 K temperature

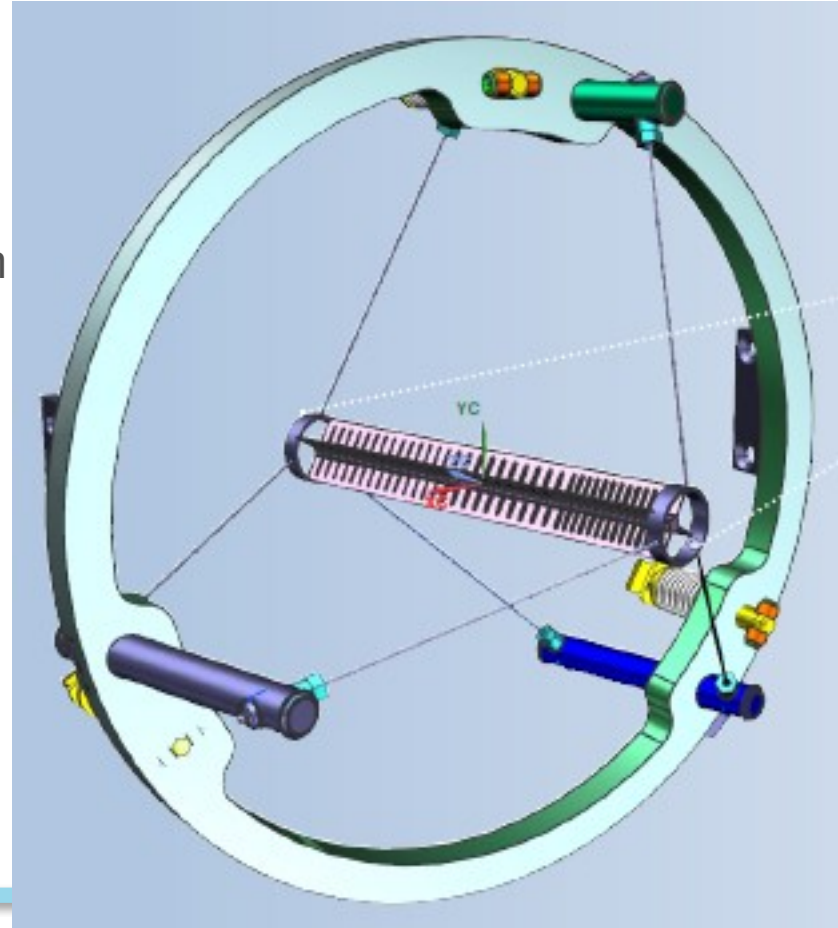

The Transport Solenoid sign-selects with a collimator

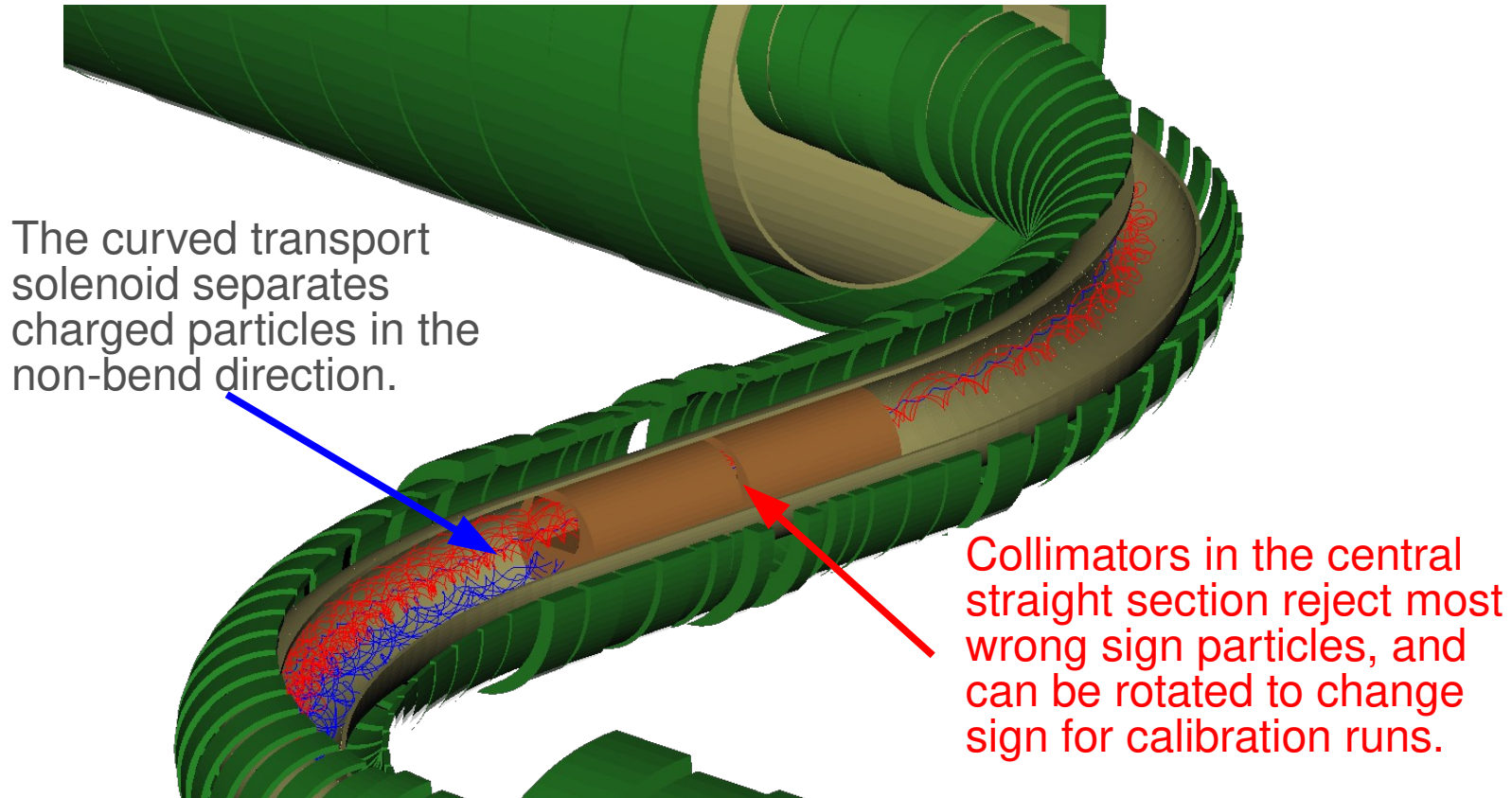

The Detector Solenoid is the heart of the experiment

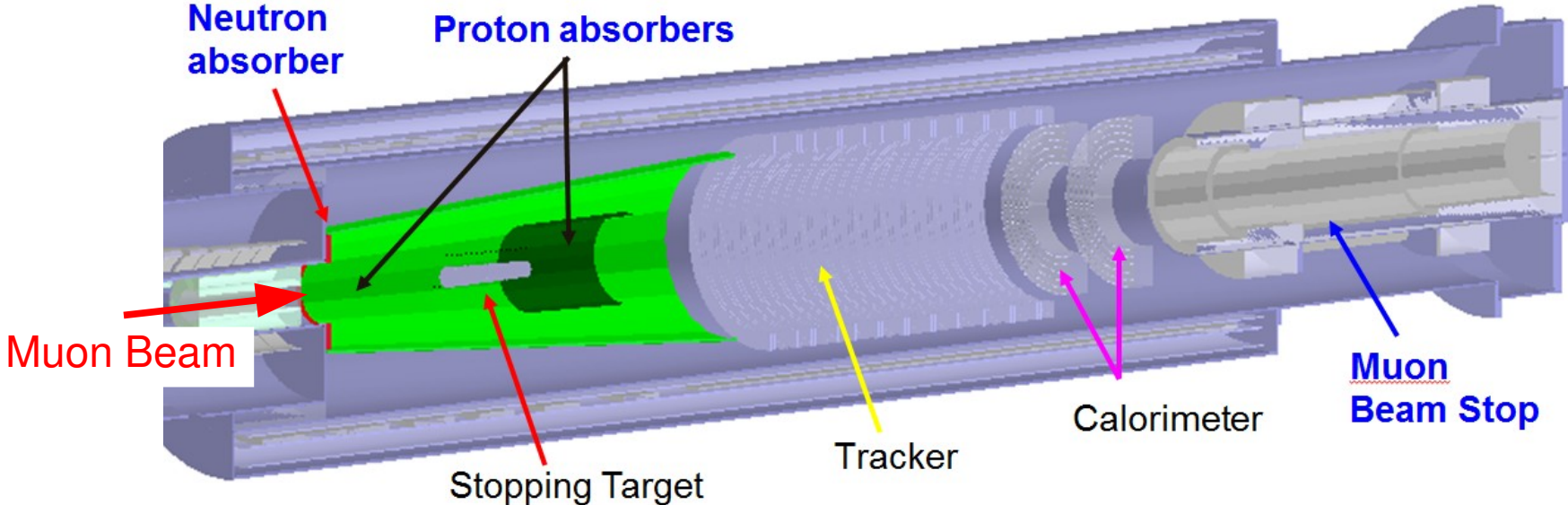

The Detector Solenoid is the heart of the experiment

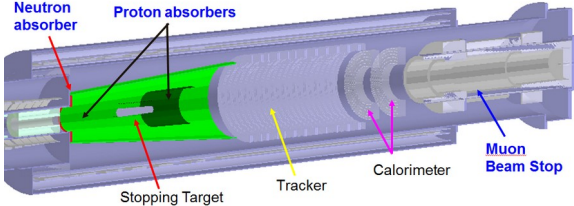
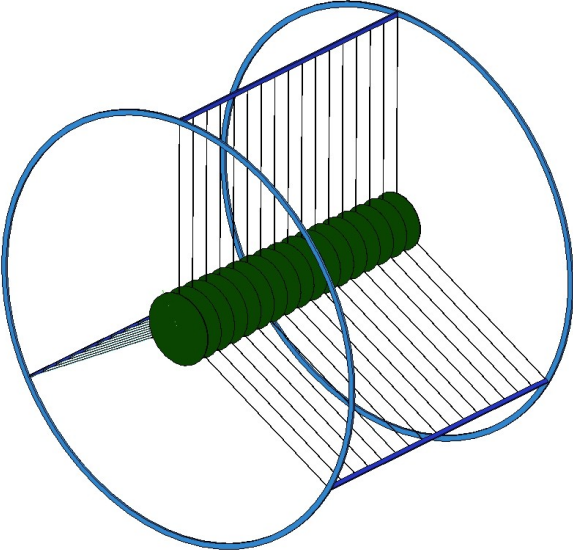

The stopping target is 17 Al foils to intercept and stop the secondary beam

The Detector Solenoid is the heart of the experiment

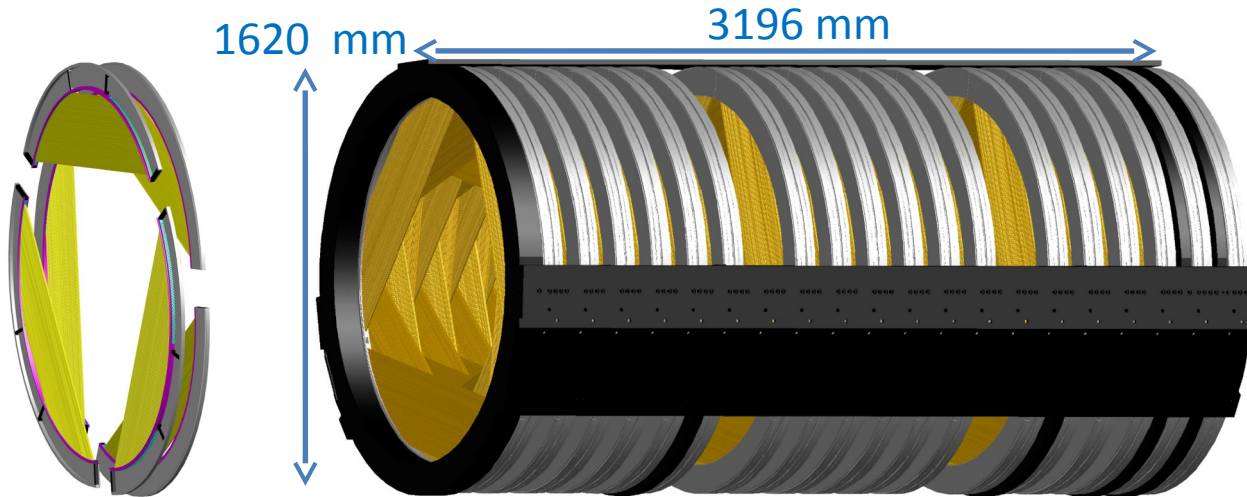
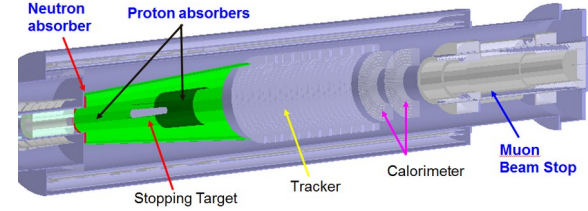

The electron tracker is a low mass straw tube design with 18 stations of tubes transverse to the secondary beam, with 21,000 straws in total.

It provides precision momentum measurement.

The Detector Solenoid is the heart of the experiment

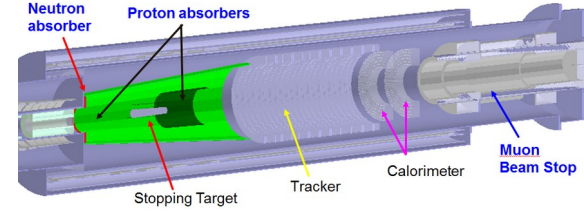
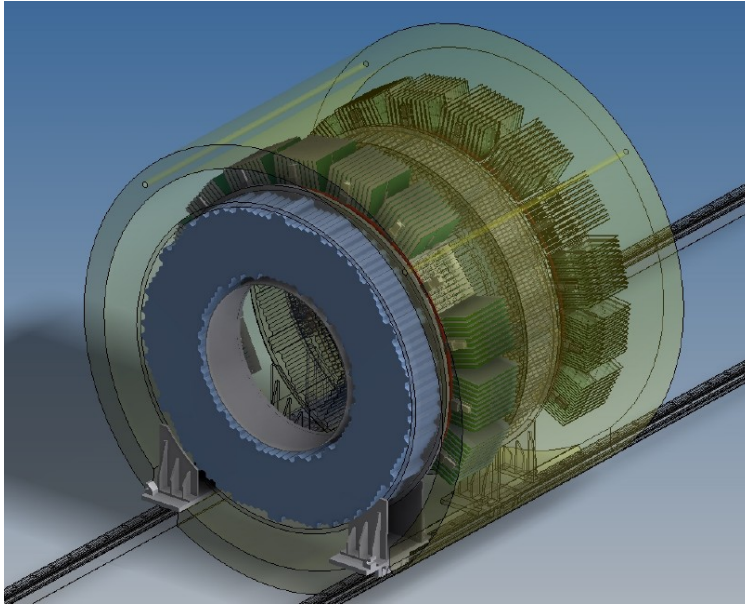

The calorimeter is a two layer, annular, undoped CsI crystal calorimeter.

It provides precision timing and particle ID

Detectors are uninstrumented along the axis of the solenoid

The vast majority of remnant beam, brehmstrahlung, and muon decay products escape down this central hole and are captured in a muon beam stop designed to prevent “back splash”

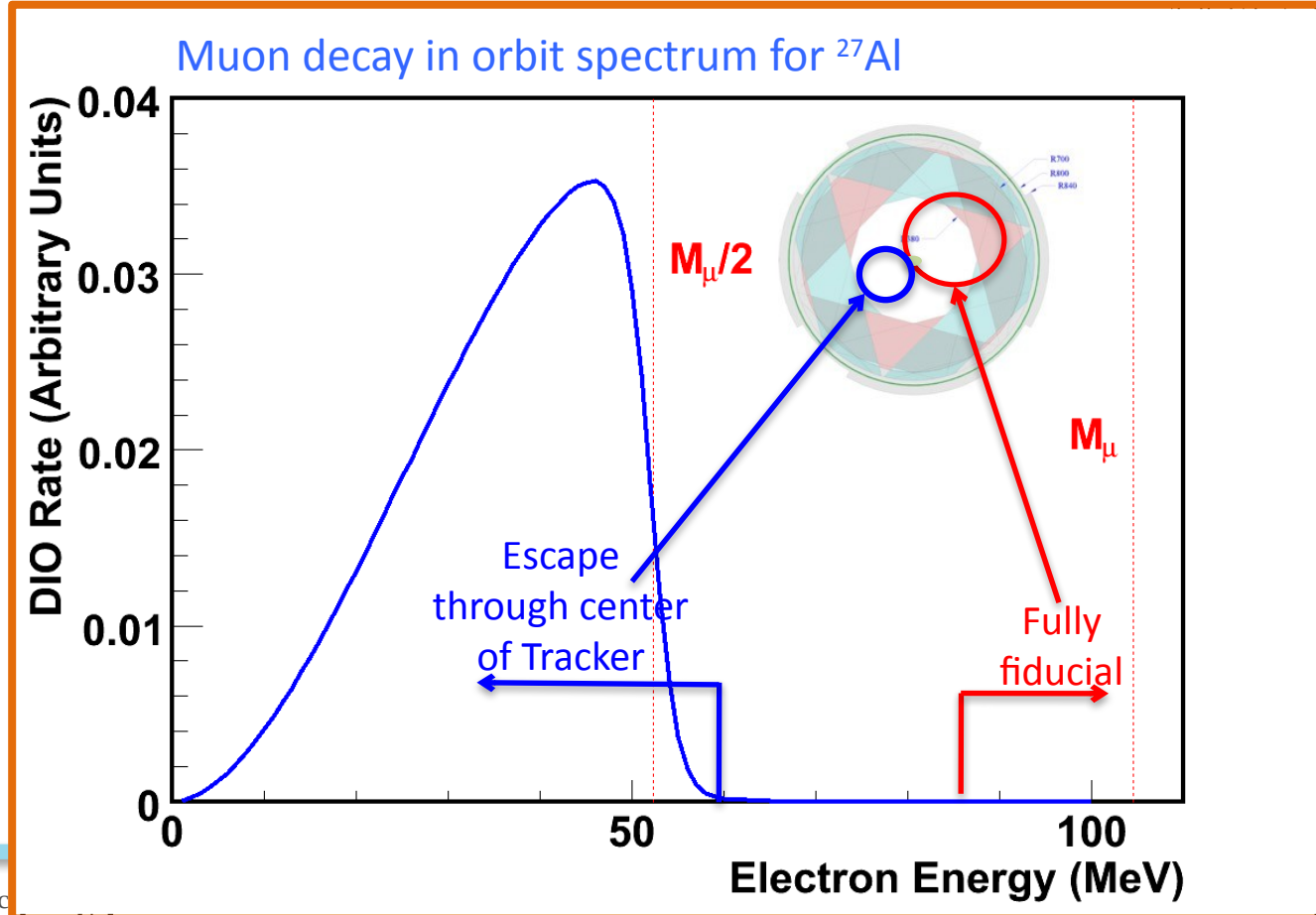

Mu2e running will be split by the LBNF shutdown

Construction should complete in 2025, with commissioning and Run 1 physics data in 2026-2027.

Recently completed a sensitivity estimate for Run 1:

- 5σ discovery $R = 1.1 \times 10^{-15}$
- 90% CL $R < 5.9 \times 10^{-16}$
- 1000x better than SINDRUM-II
- Paper to be submitted to Universe

Run 2 will commence in 2029 with a goal to improve the measurement to 10000x better than SINDRUM-II.

For the full dataset, our expected sensitivity

- 90% CL $R < \text{few} \times 10^{-17}$

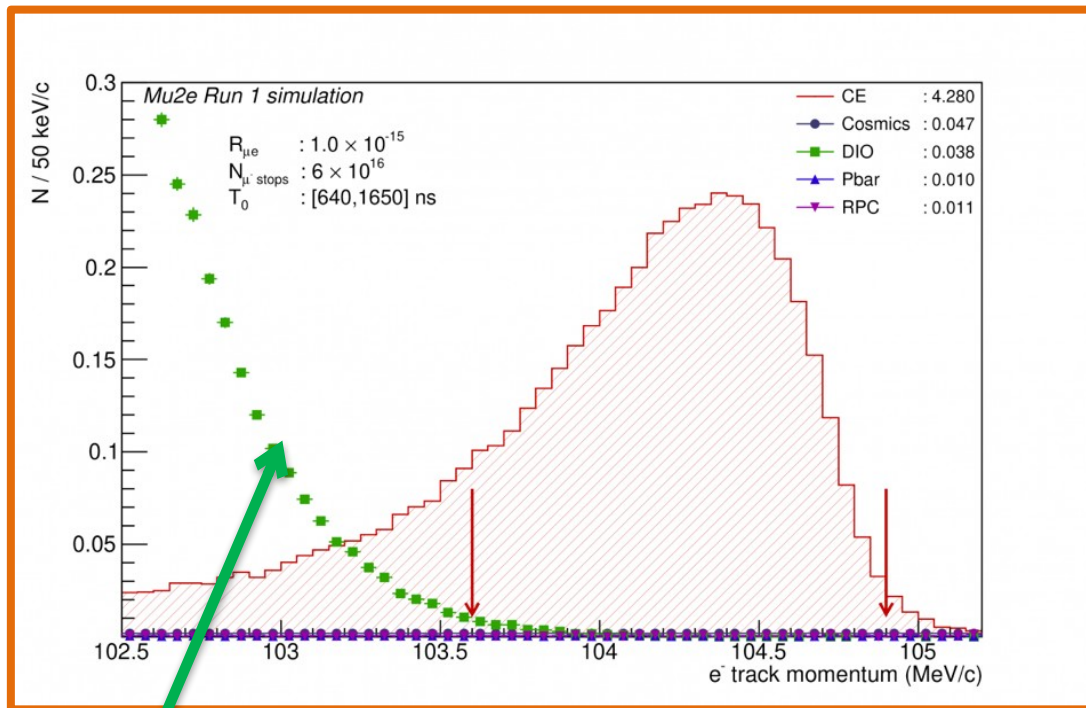

Long DIO tail due to nuclear recoil

To summarize...

- Fundamental muon physics today is focused on CLFV searches
 - $\mu \rightarrow e \gamma$
 - $\mu \rightarrow eee$
 - $\mu N \rightarrow e N$
- Mu2e and COMET are friendly competition in the conversion search with much shared DNA
 - Both aim for a 10,000x improvement over SINDRUM-II
- We're either going to discover new physics in the next few years, or we'll provide a nearly unprecedented improvement in sensitivity, either of which beg for a next generation experiment
 - Although I couldn't talk about them today, there are ideas to gain an additional 2-3 orders of magnitude with future searches in these and other channels