



Istituto Nazionale di Fisica Nucleare
SEZIONE DI FERRARA

KLOE to SAND

Magnet Coil: dismantling and transport (WP5)

Review

- Services, structures and tools
- Design Status
- Working Procedure
- Organization

Cryostat and Magnet Coil: dimensions and weight

nil volentibus arduum

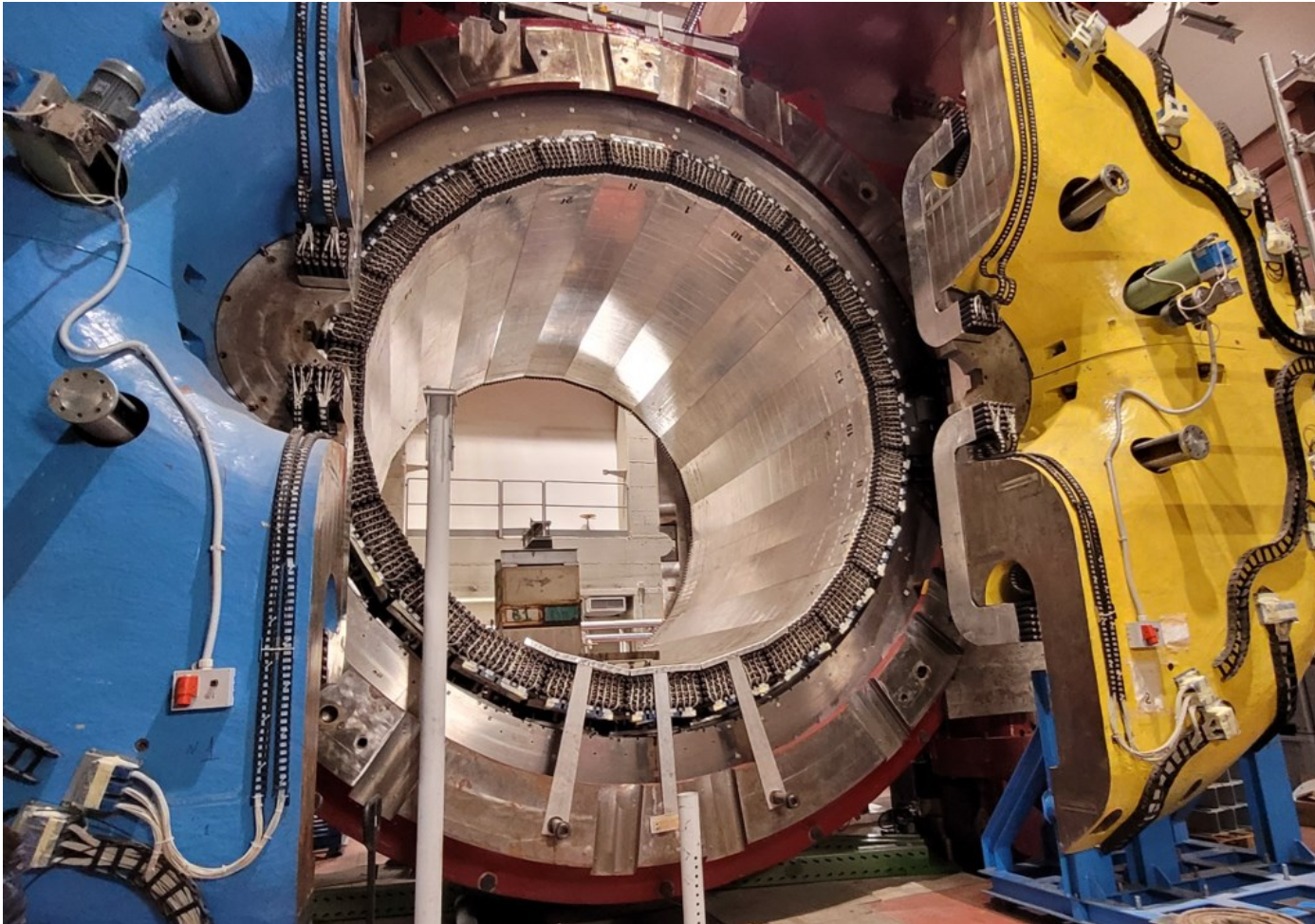

(Cryostat + Coil) dimensions: $\Phi = 5766$ mm ; $L = 4400$ mm

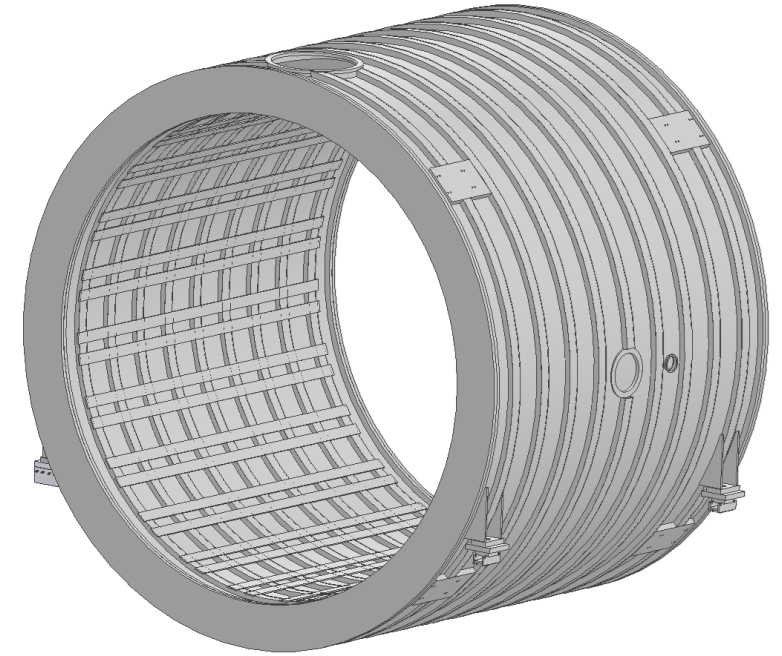

Cryostat + Coil \approx 40 tons

20 x



Services, structures and tools: extraction (@LNF) & insertion (@FNAL)

nil volentibus arduum



Crane = 22 t + 22 t

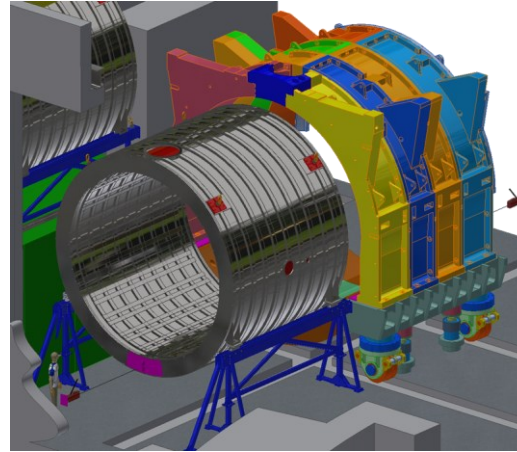

Extraction/Insertion Tool



Loading Dock

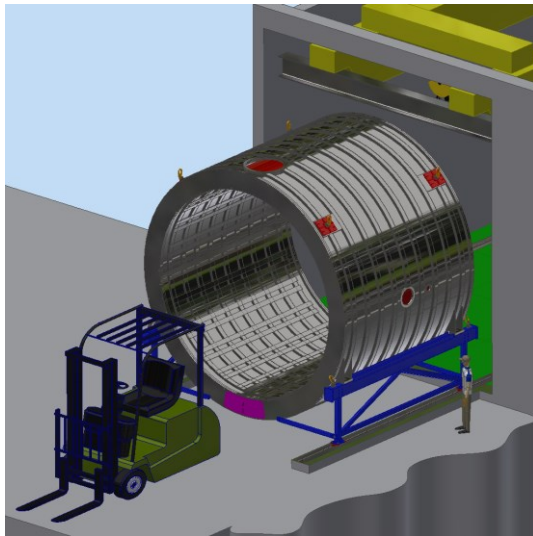

Trolley System

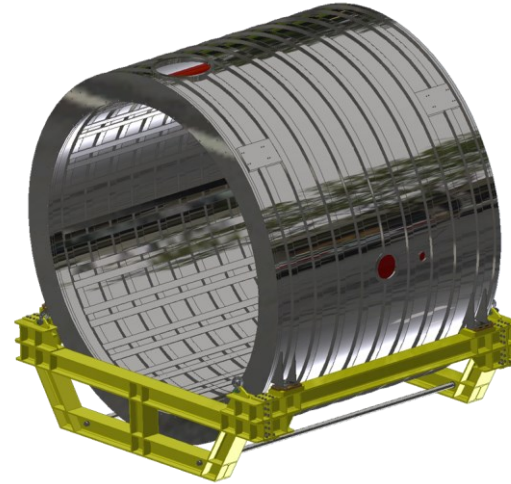

Cradle



Lugs

Services and tools: loading and unloading operations



Two cranes



Lifting Beam



Design Status

Design Status

Tool	3D Model	Workshop Drawings	Sizing and verification calculations	Certification (CE and ASME)	Technical Specification for tender
Extraction and Insertion	Done	Done	Done	To be done	Done
Trolley System	Done	Done	Done	To be done	Done
Cradle	Done	Done	Done	To be done	Done
Lugs	Done	Done	Done	To be done	Done
Tirfort System	Done	Done	Done	To be done	Done

Other project documents	
Work Practices Plan (operating procedure)	Under review
Safety Plan	Under preparation

Design Status: transport cradle

nil volentibus arduum

All workshop drawings are ready
Technical specification is ready

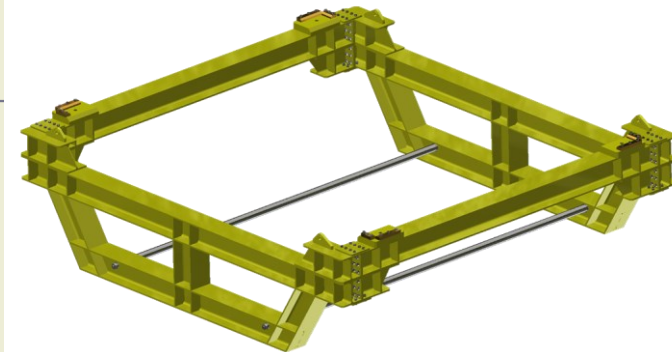
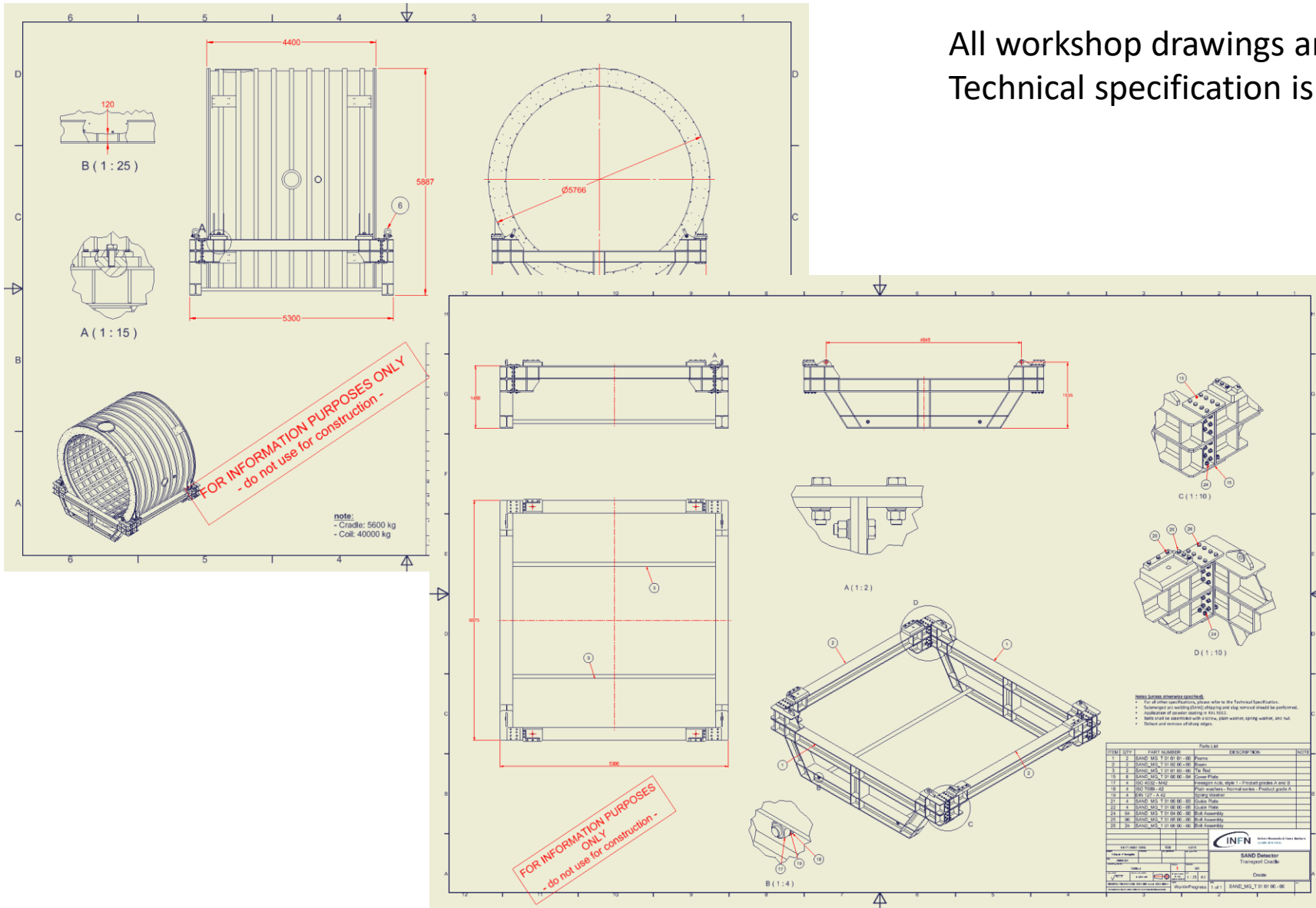

Design Status: extraction/insertion tool

nil volentibus arduum

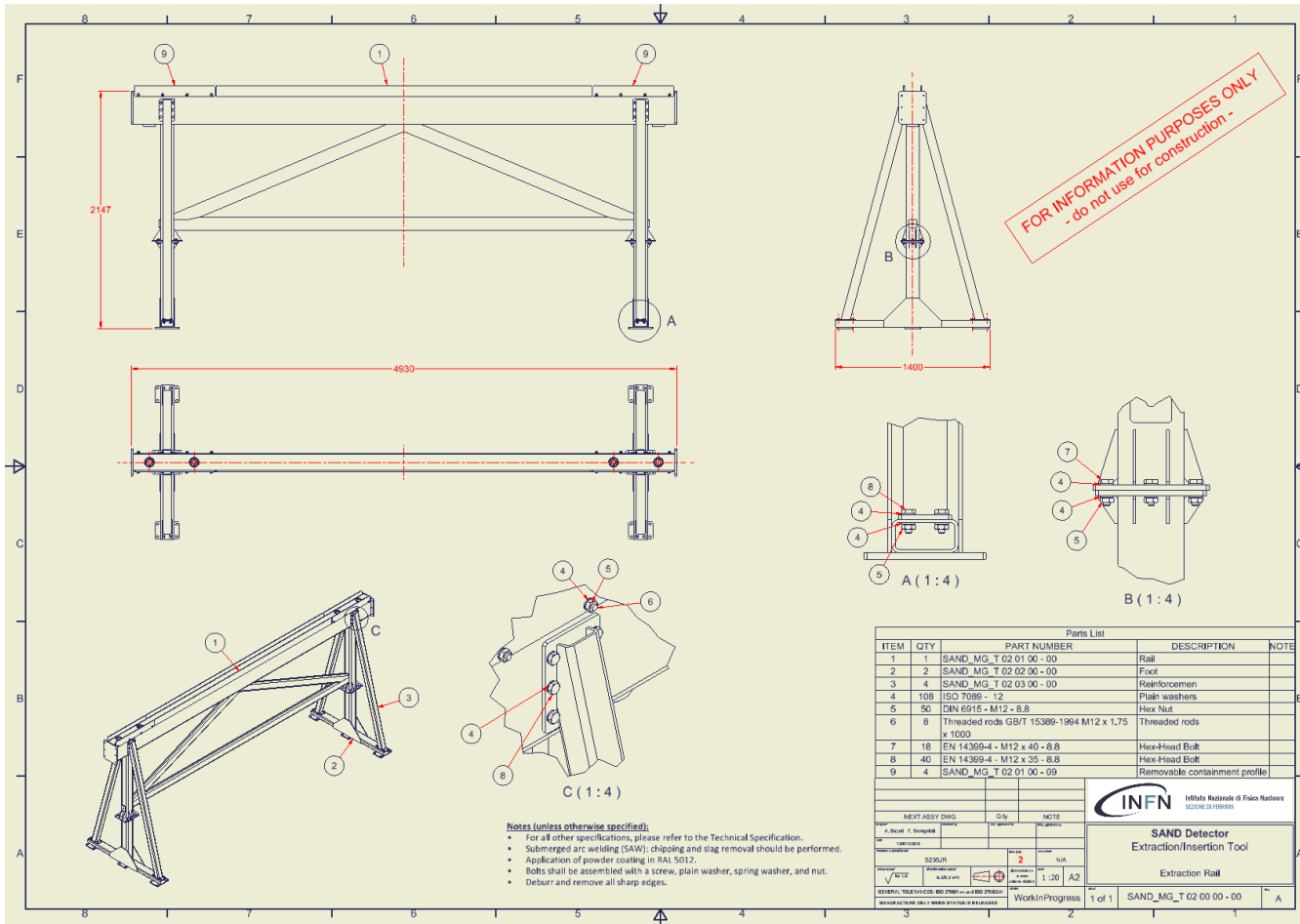

All workshop drawings are ready
 Technical specification is ready

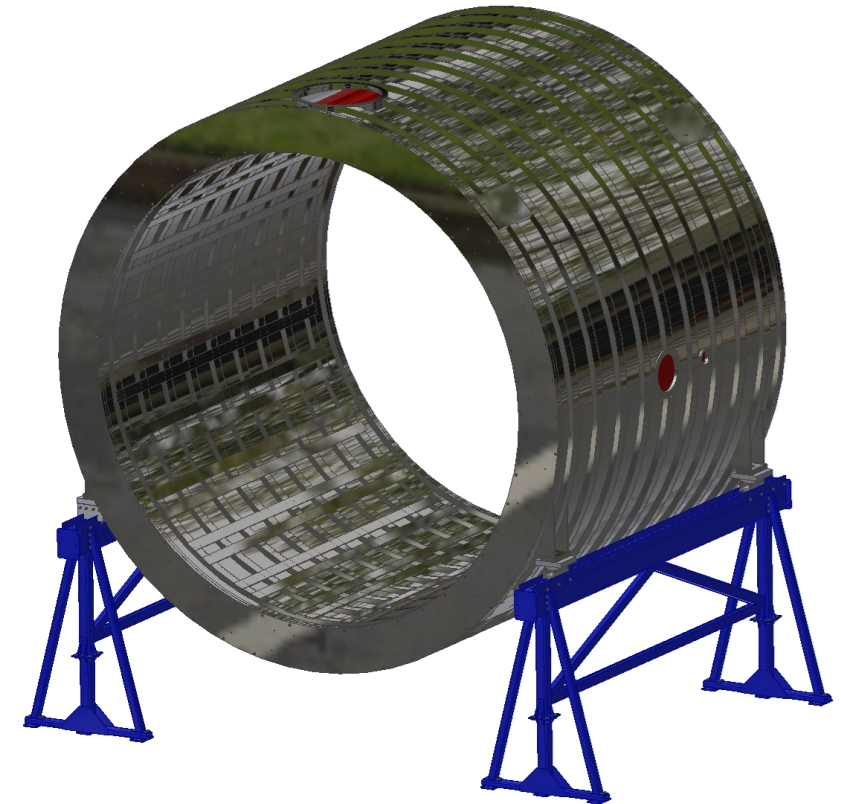

Design Status: lugs

nil volentibus arduum

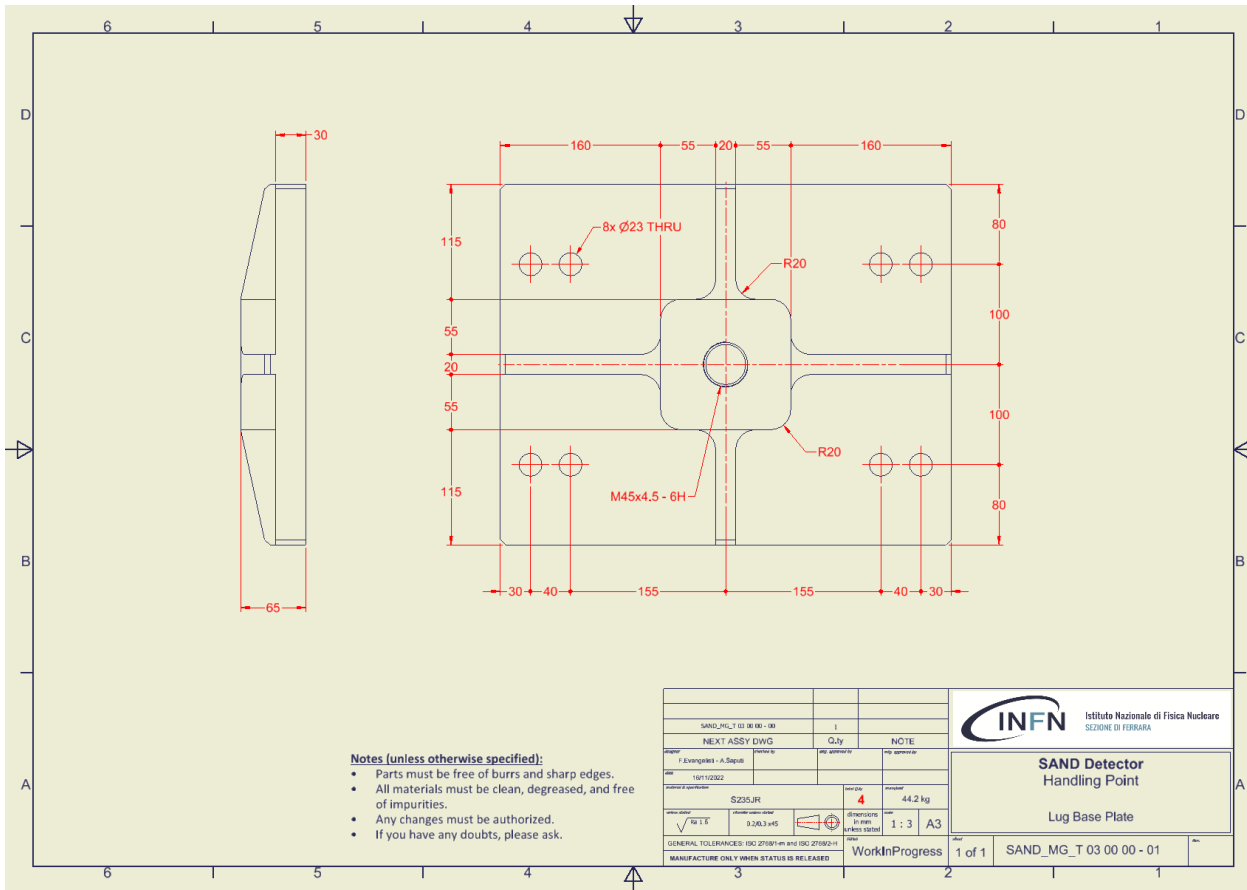

All workshop drawings are ready
Technical specification is ready

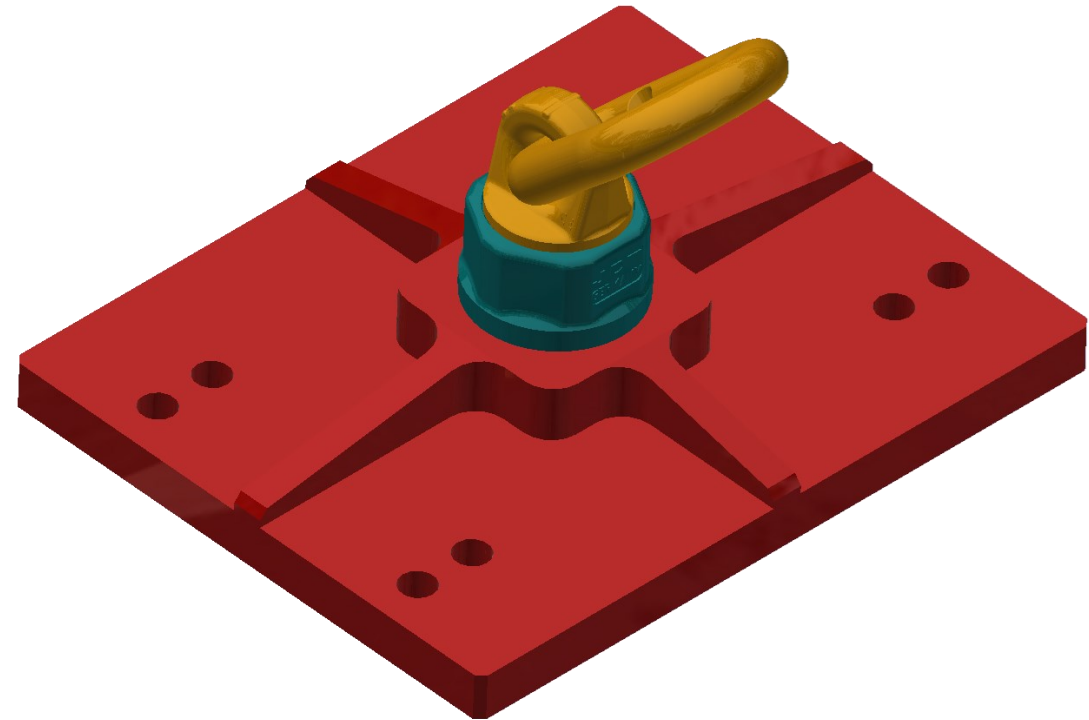

Design Status: trolley system

nil volentibus arduum

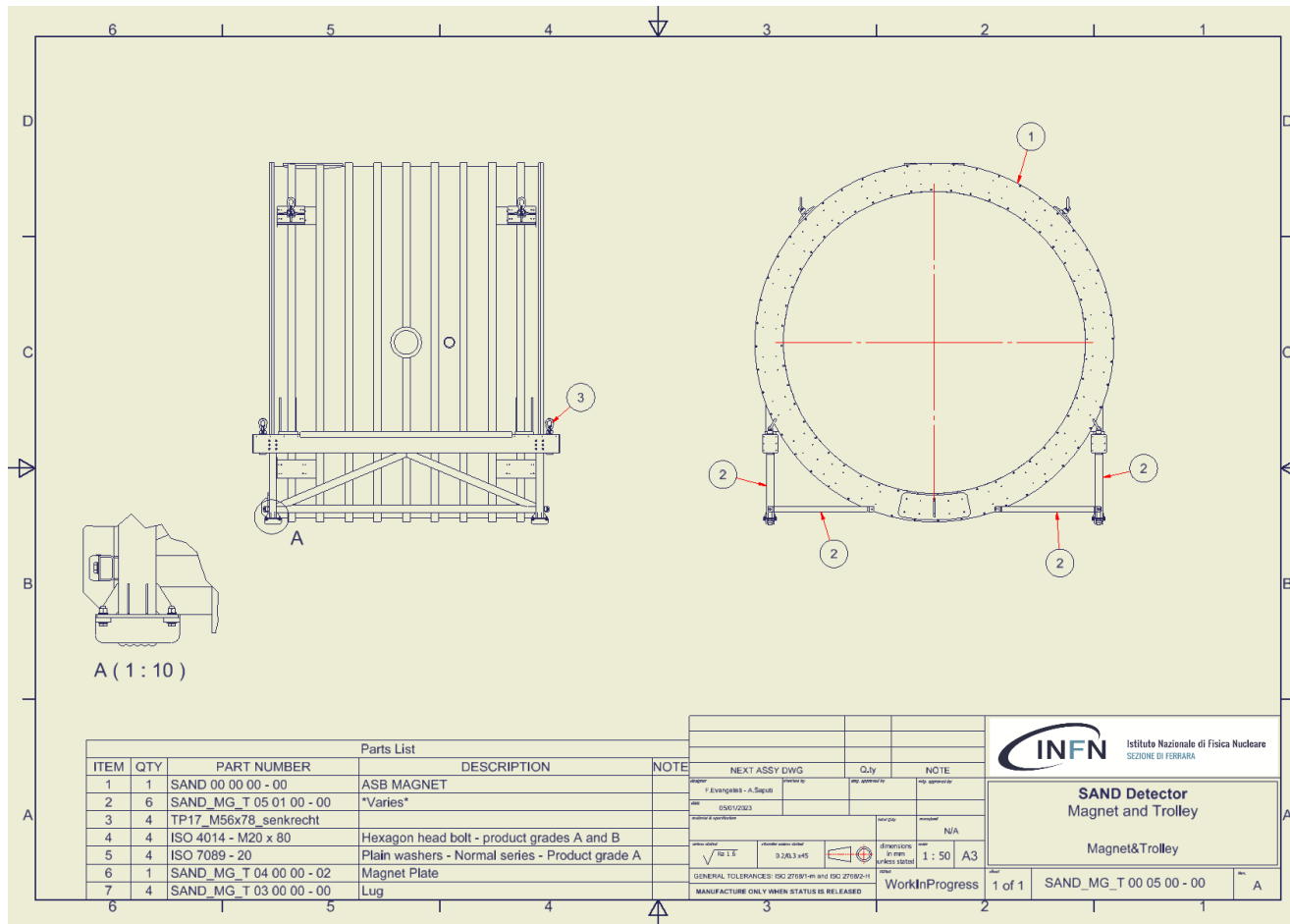

All workshop drawings are ready
 Technical specification is ready

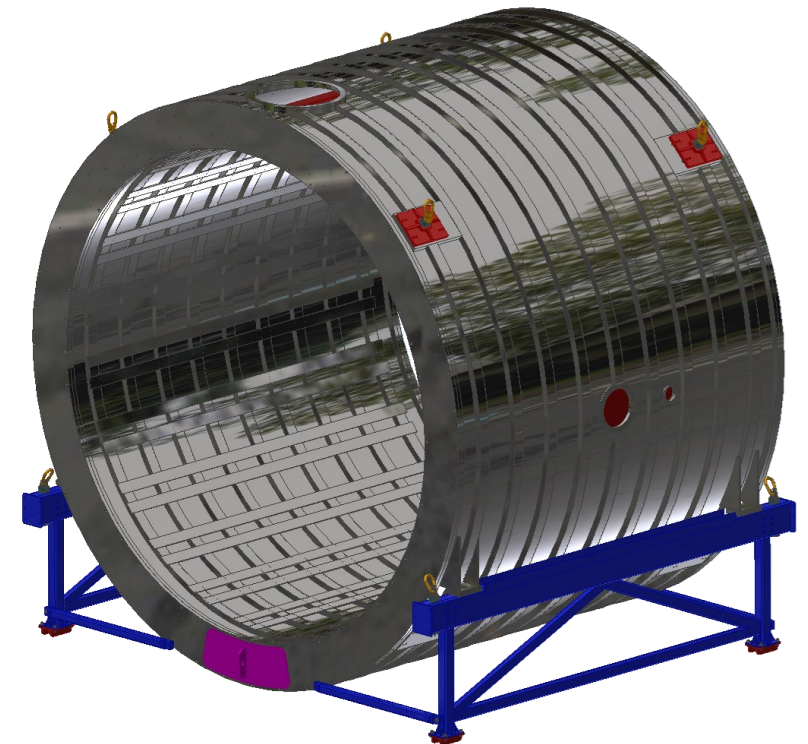

Working Procedure

Indoor and outdoor working area

nil volentibus arduum

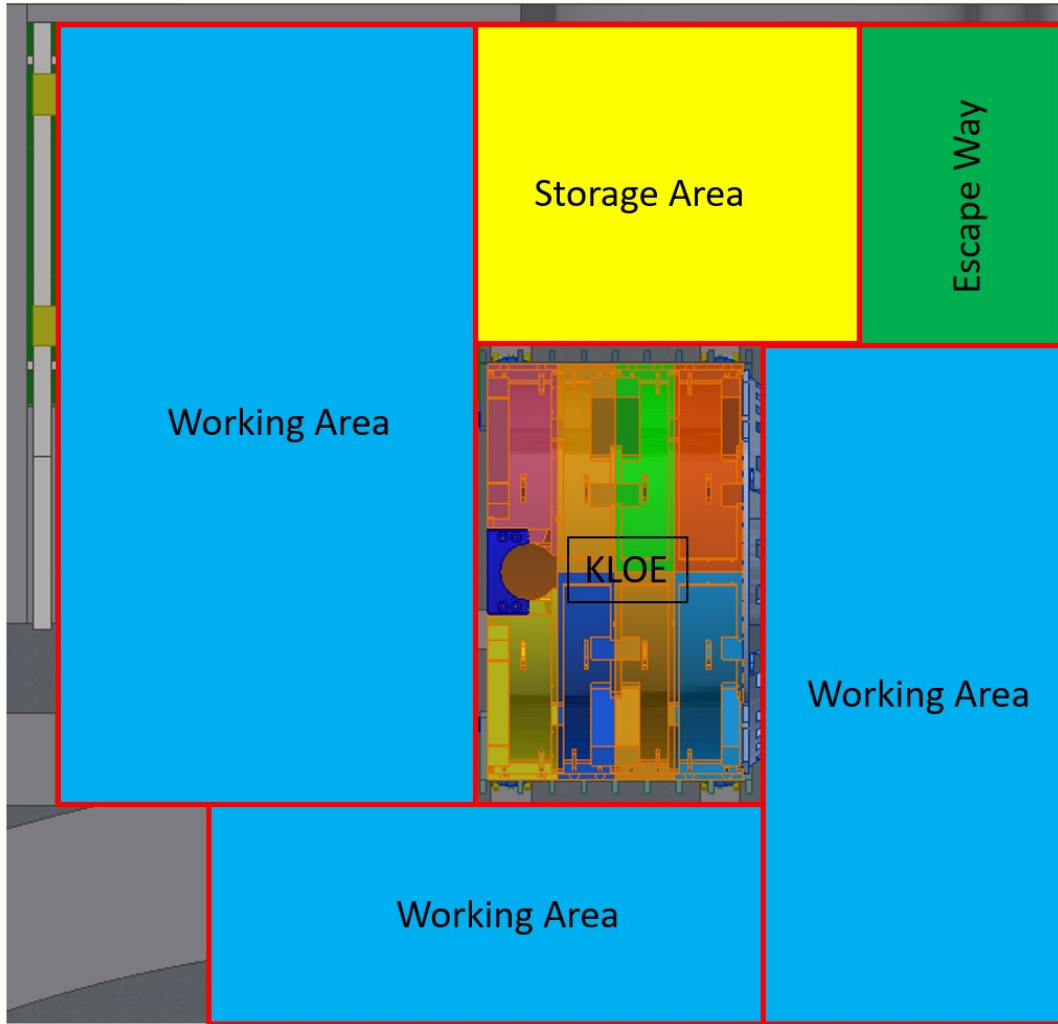

KLOE Assembly Hall

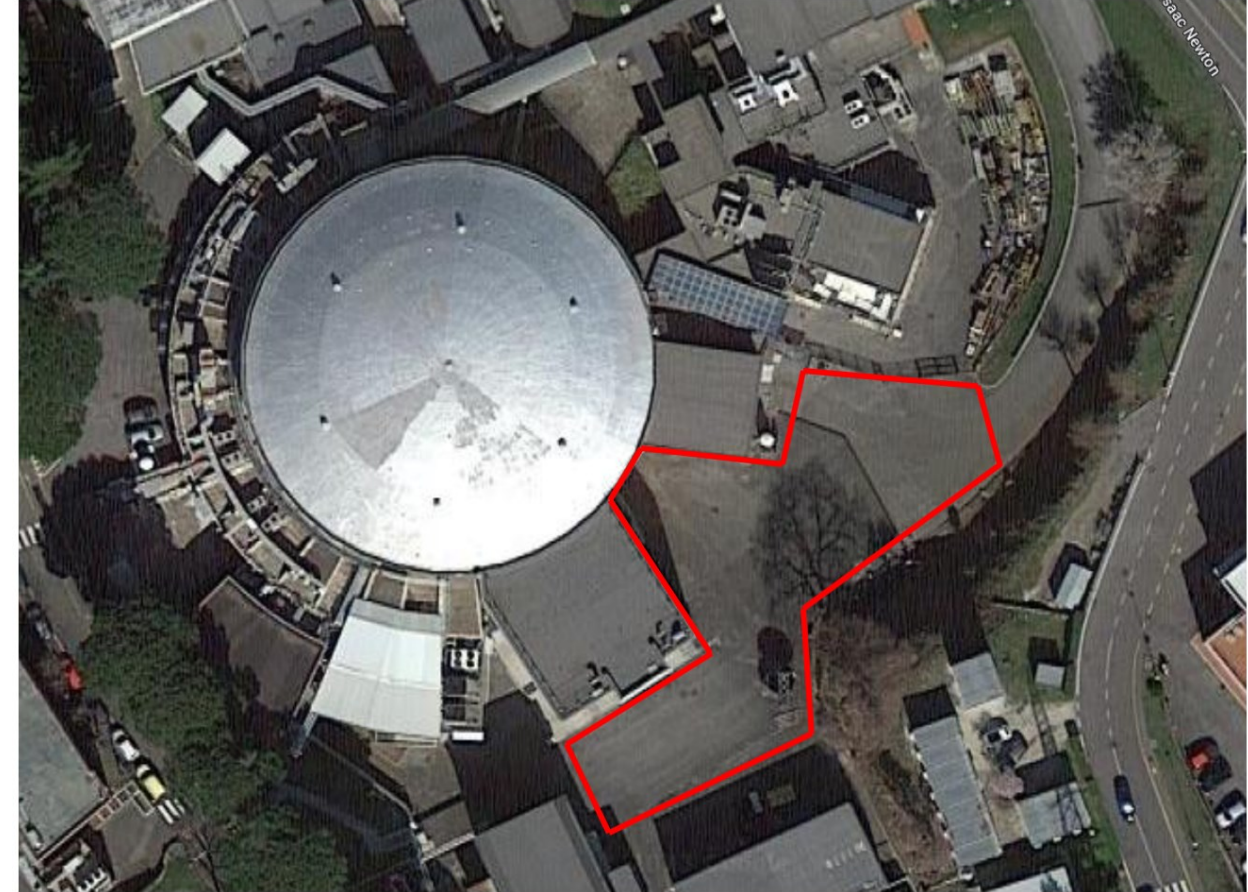

Outdoor Working Area

Magnet extraction: working procedure

nil volentibus arduum

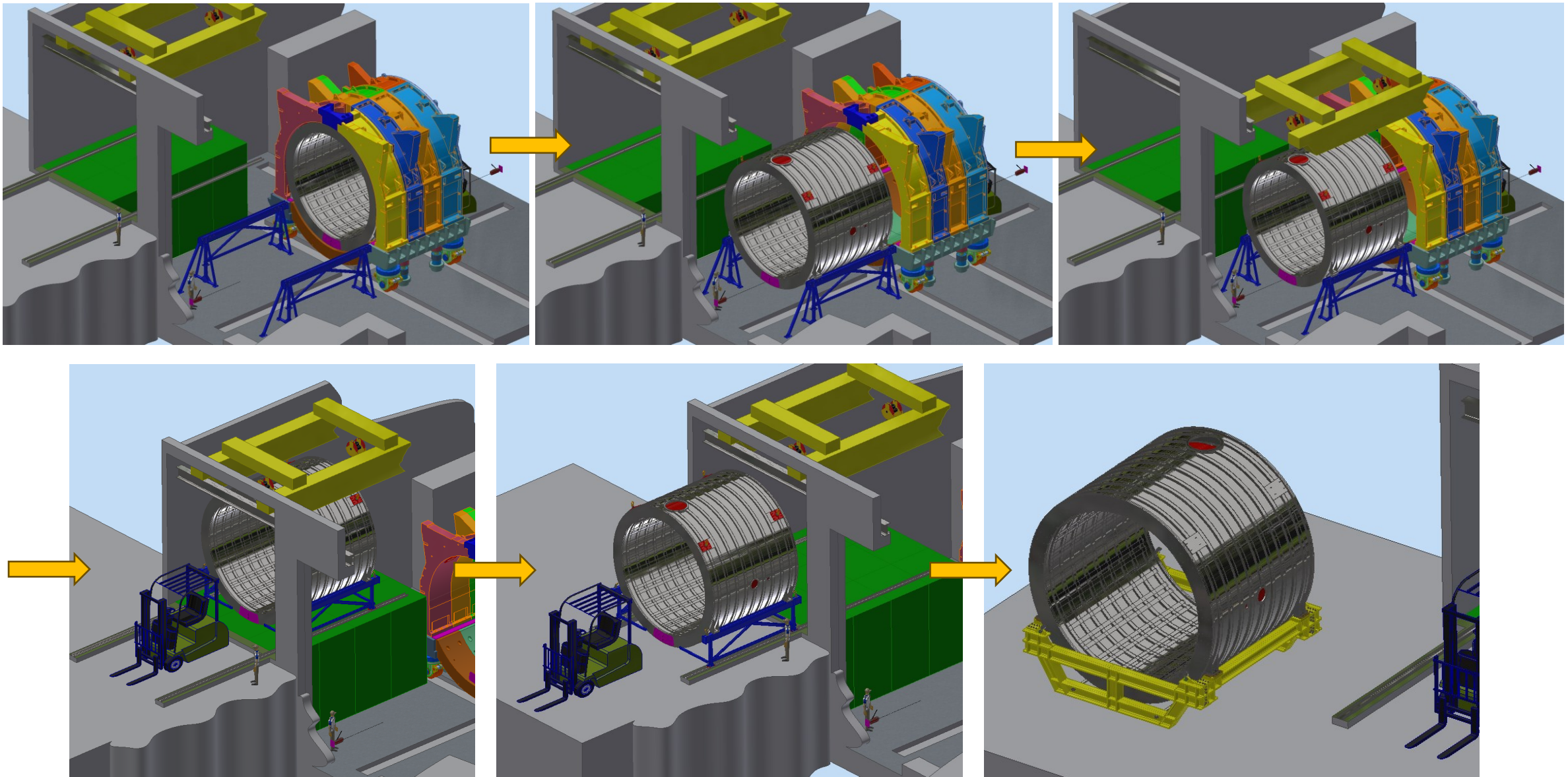

Magnet: preparation for transport

nil volentibus arduum

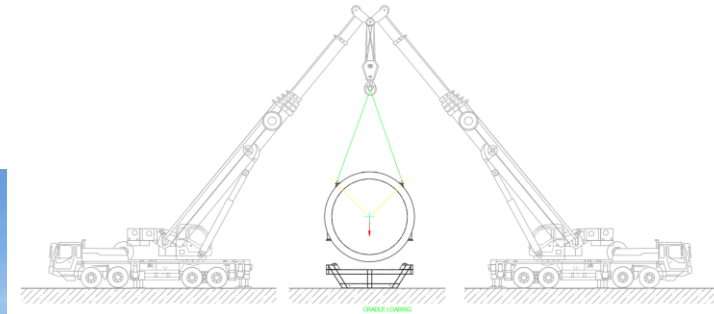
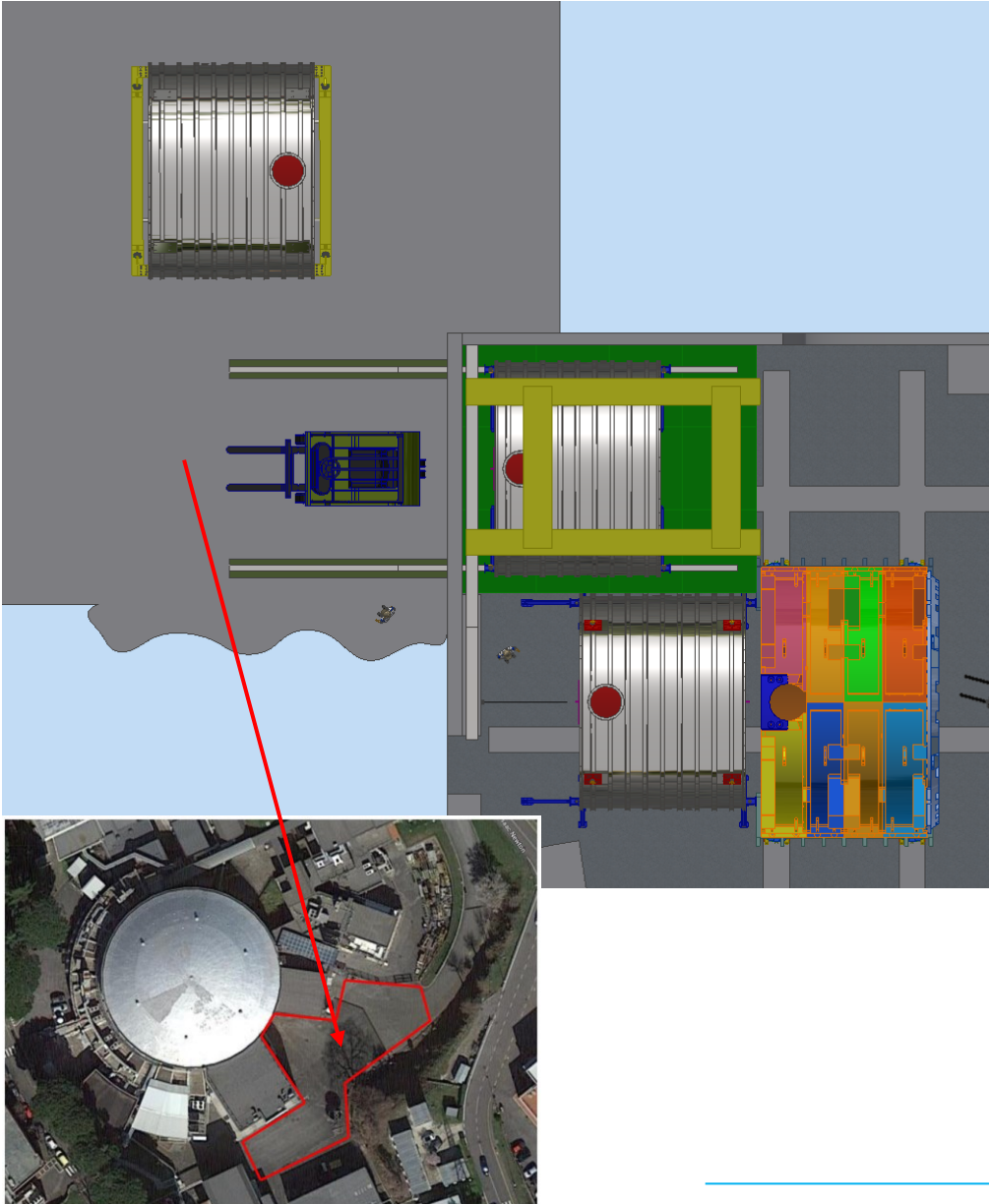

Handling

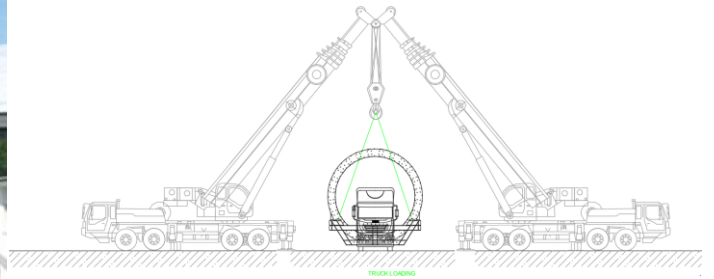

Magnet: temporary storage @ LNF

nil volentibus arduum



Protection Wrapping

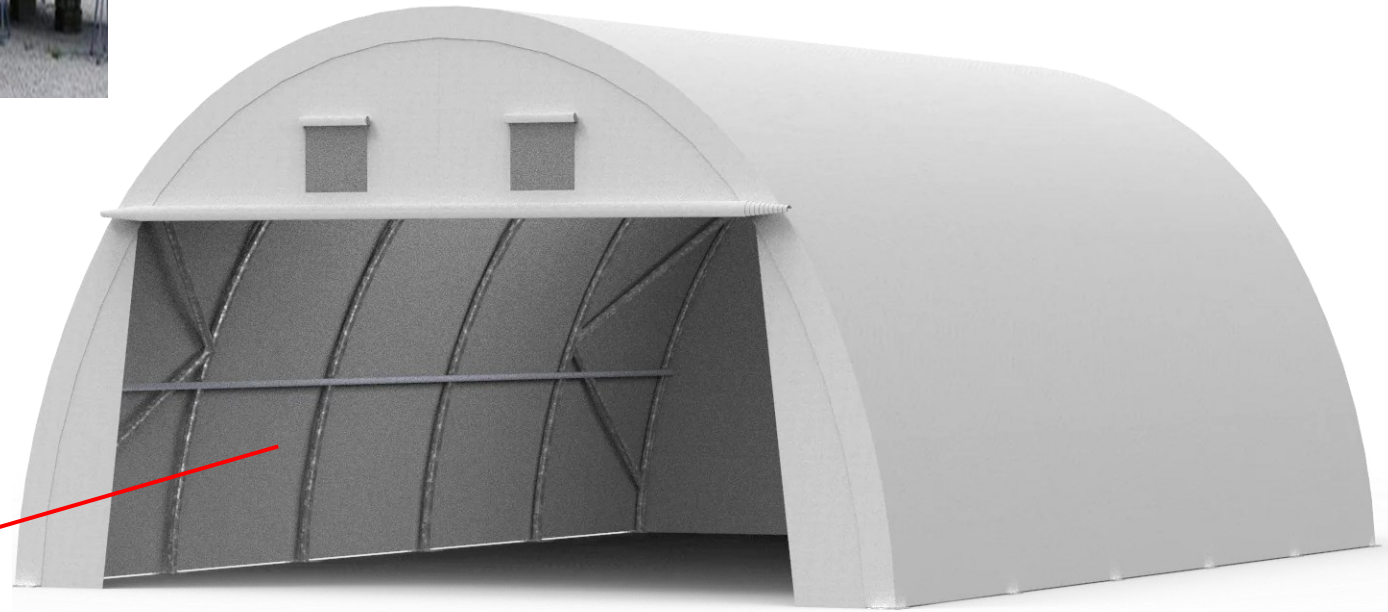
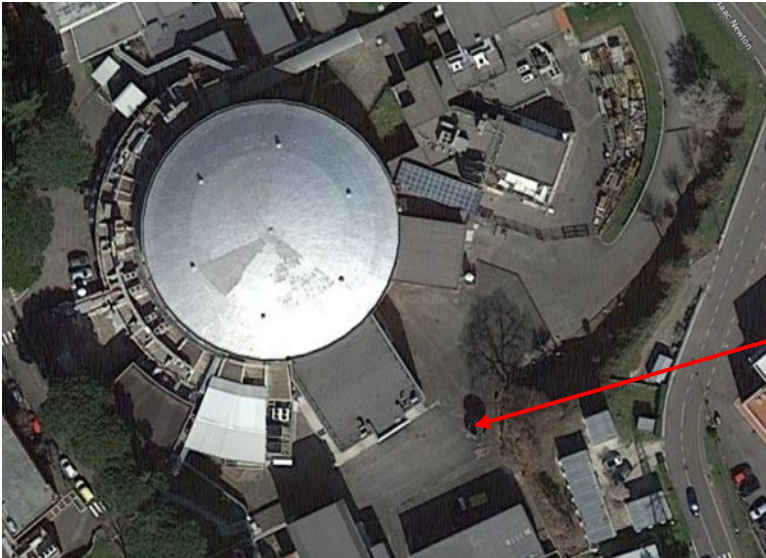

Temporary Storage Tent

Magnet: transport from LNF to FNAL

nil volentibus arduum



On the way to LNF



Loading phase



On the boat

Preparatory work

Service Turret: removal

nil volentibus arduum

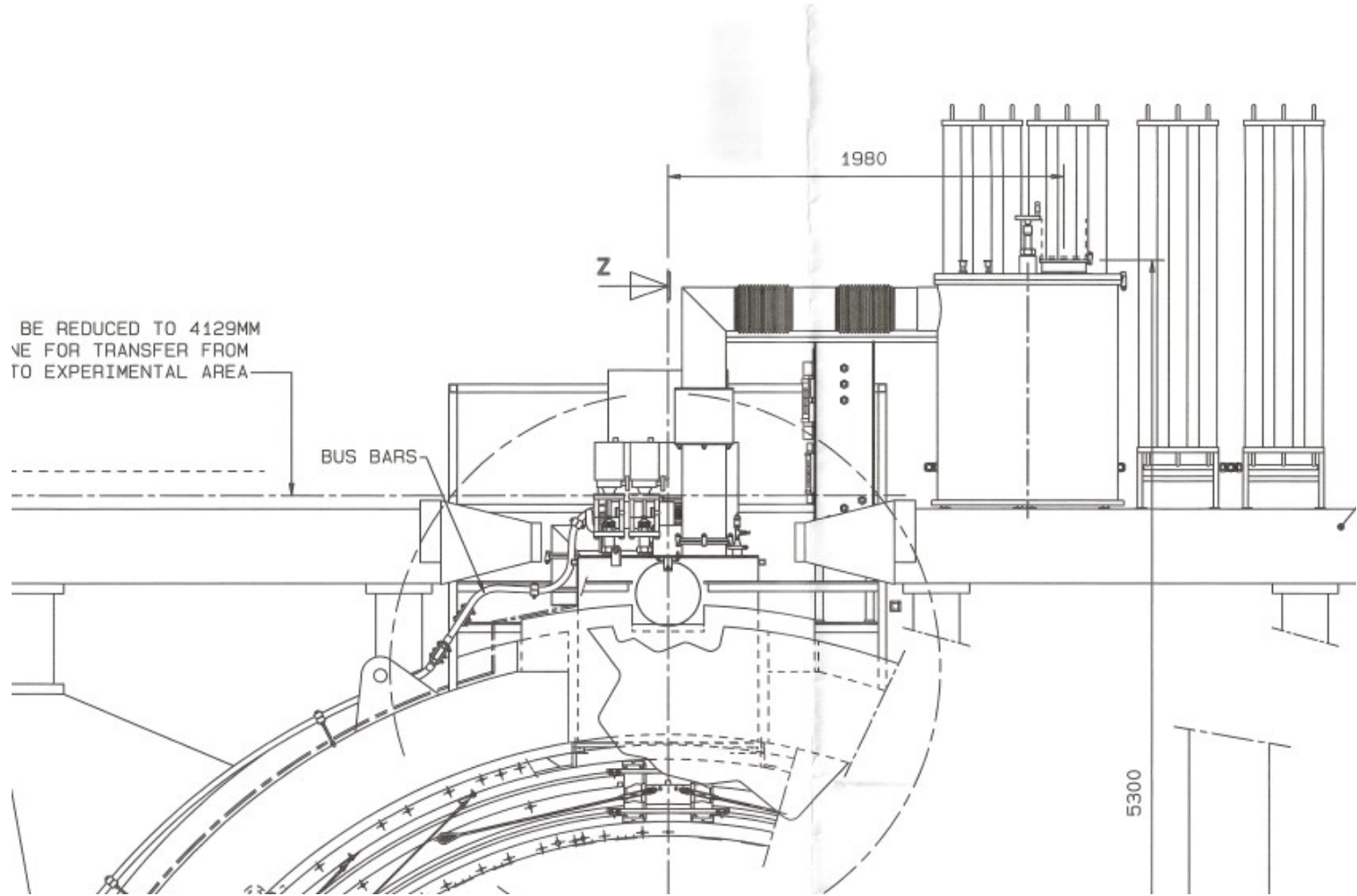

Rings removal

nil volentibus arduum

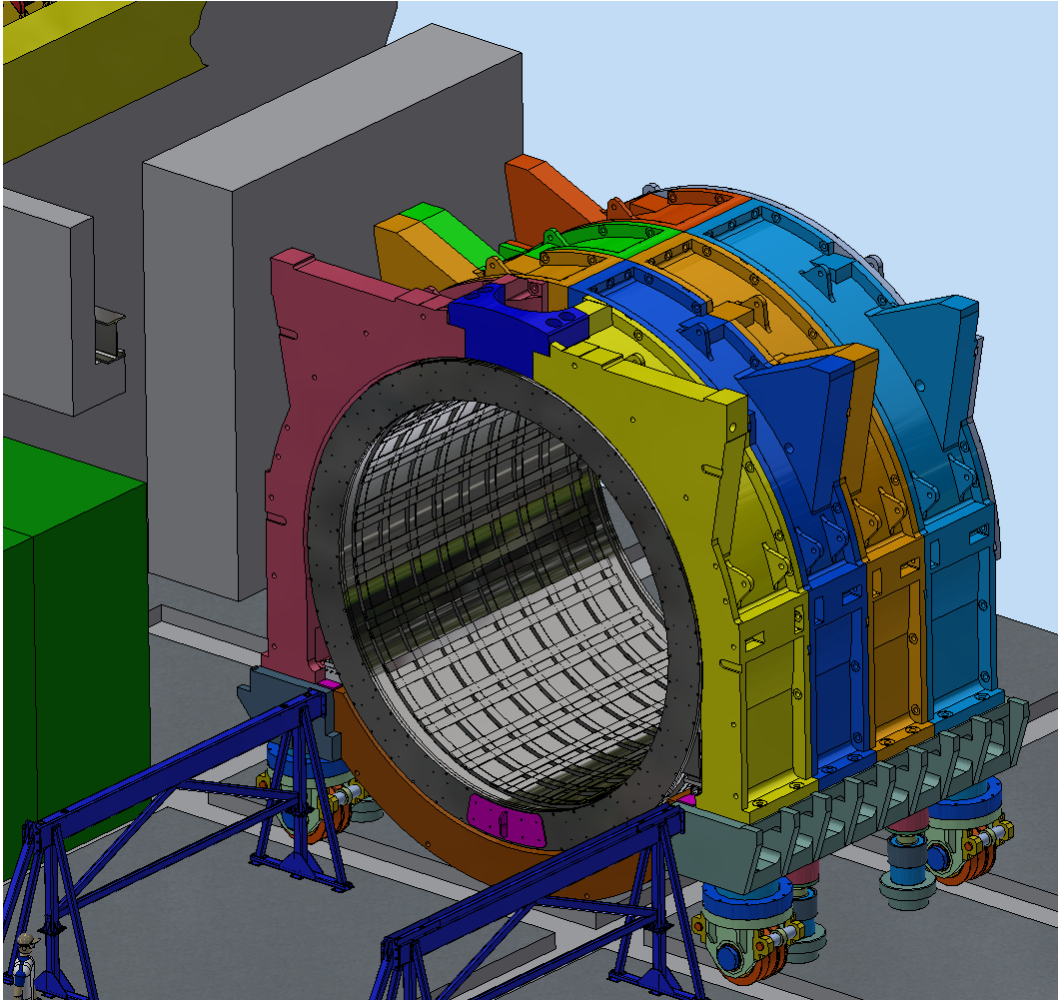

Front (parking side)

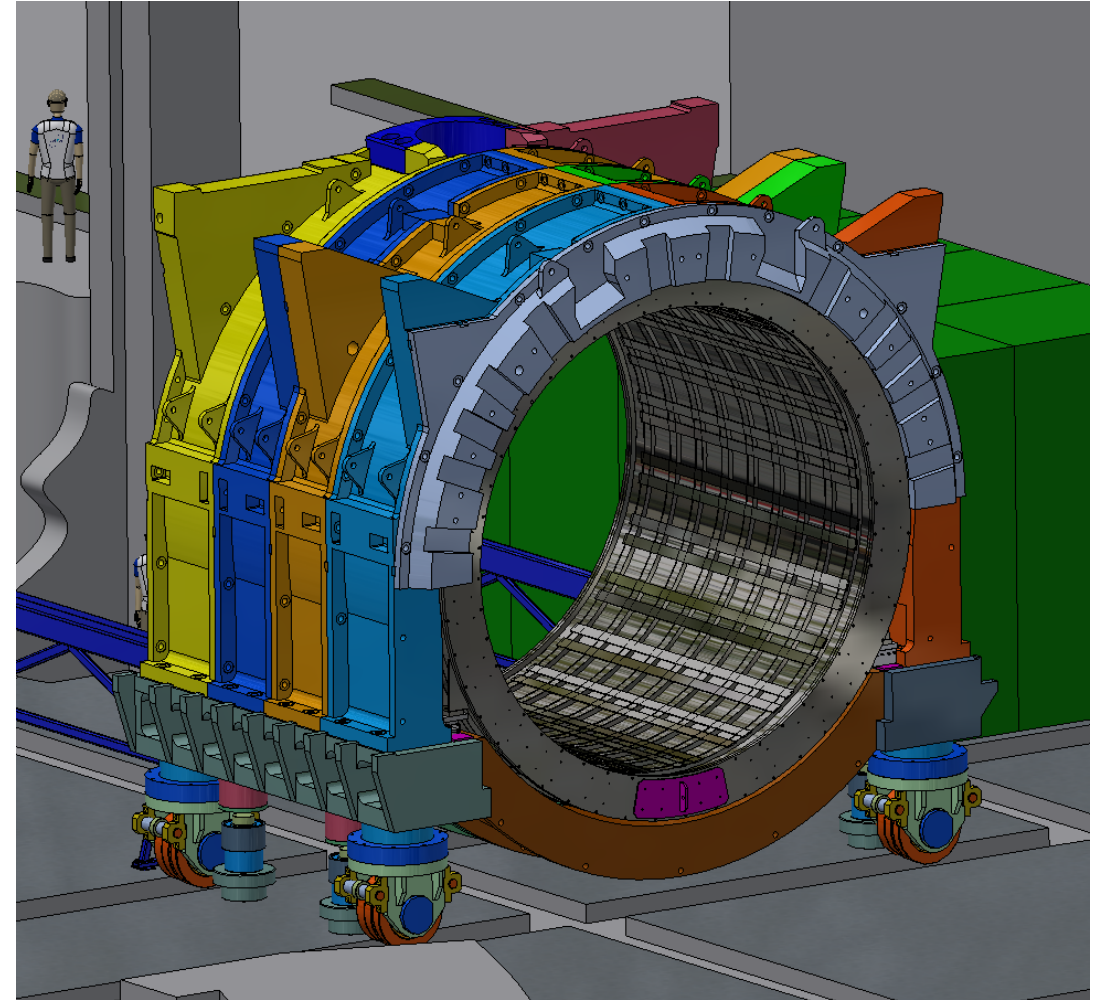

Back (DAFNE side)

Installation of loading dock and rails

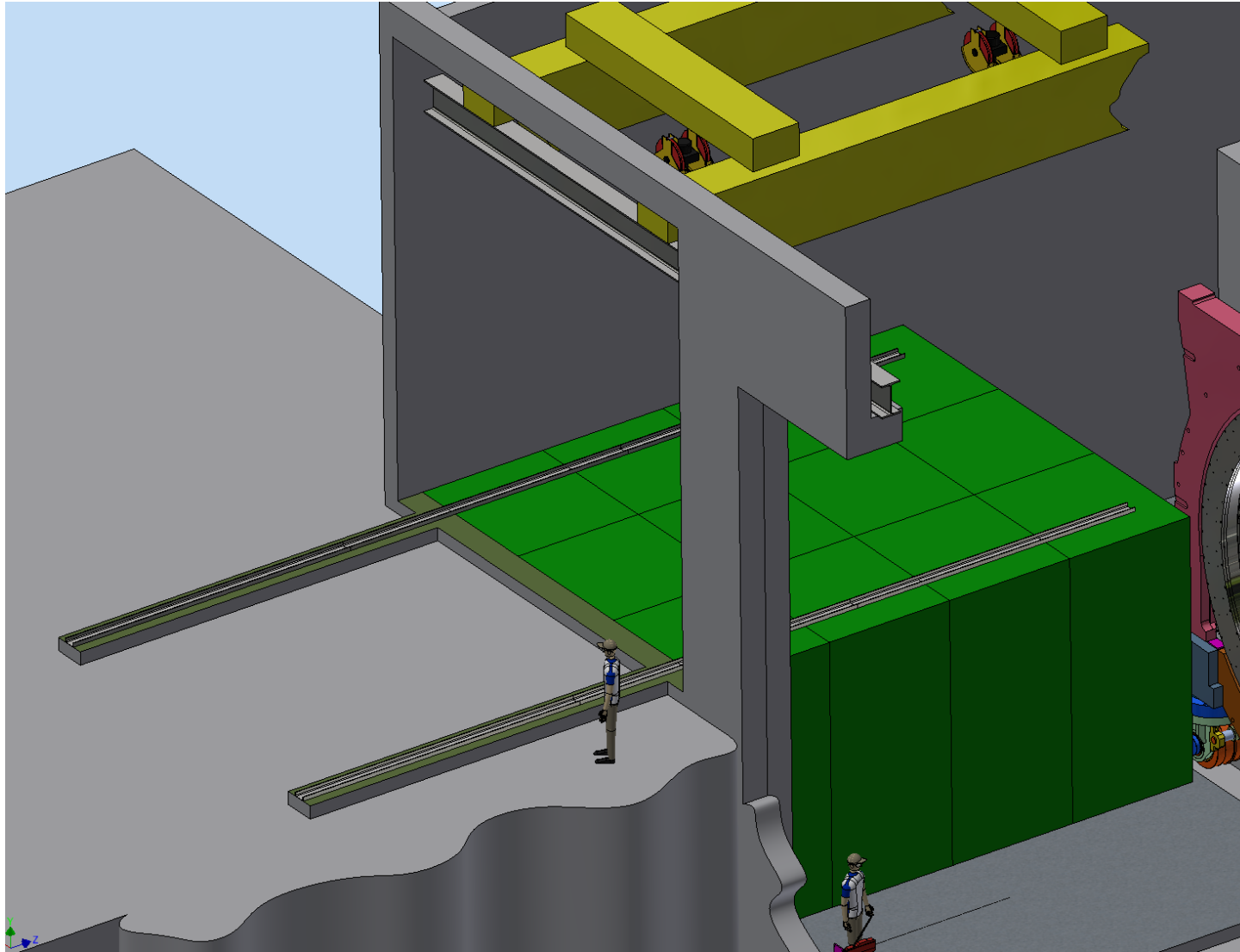

The loading dock shall be extended to allow the magnet to be moved out of the assembly hall. The new design will include reinforced structures and appropriate safety measures to handle the weight and size of the magnet.

Two rails shall be installed to slide the magnet out of the assembly hall. The installation process will include precise alignment and secure anchoring of the rails to handle the weight and dimensions of the magnet.

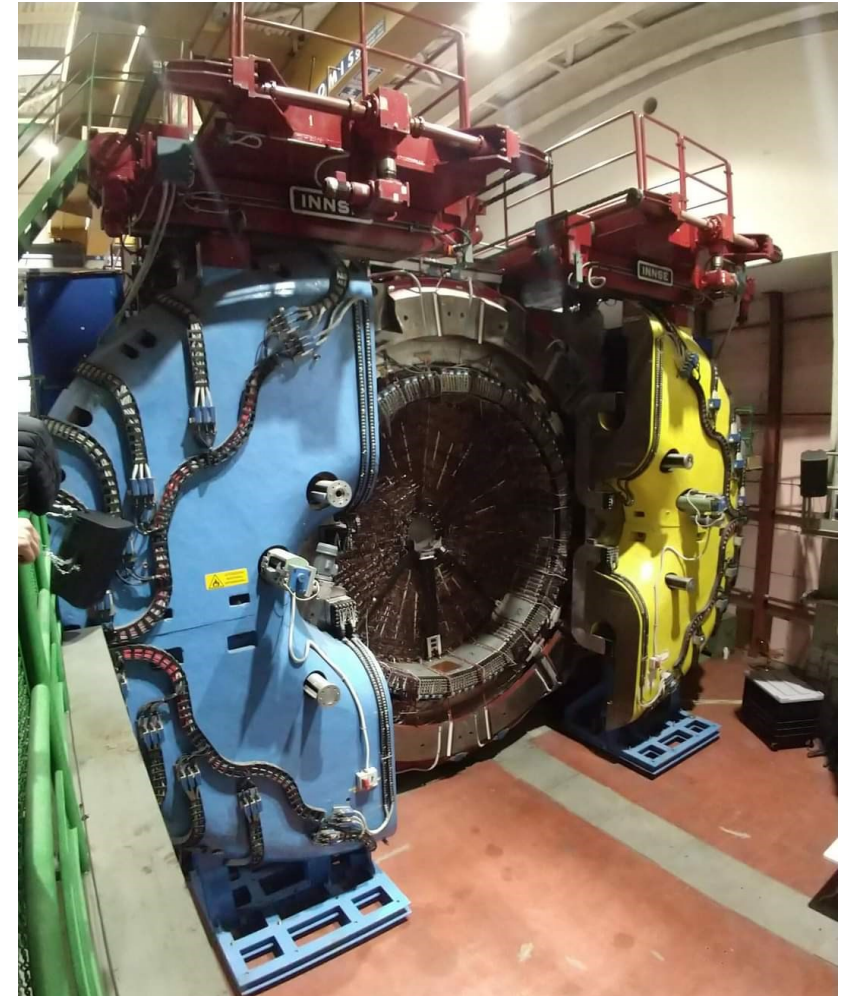
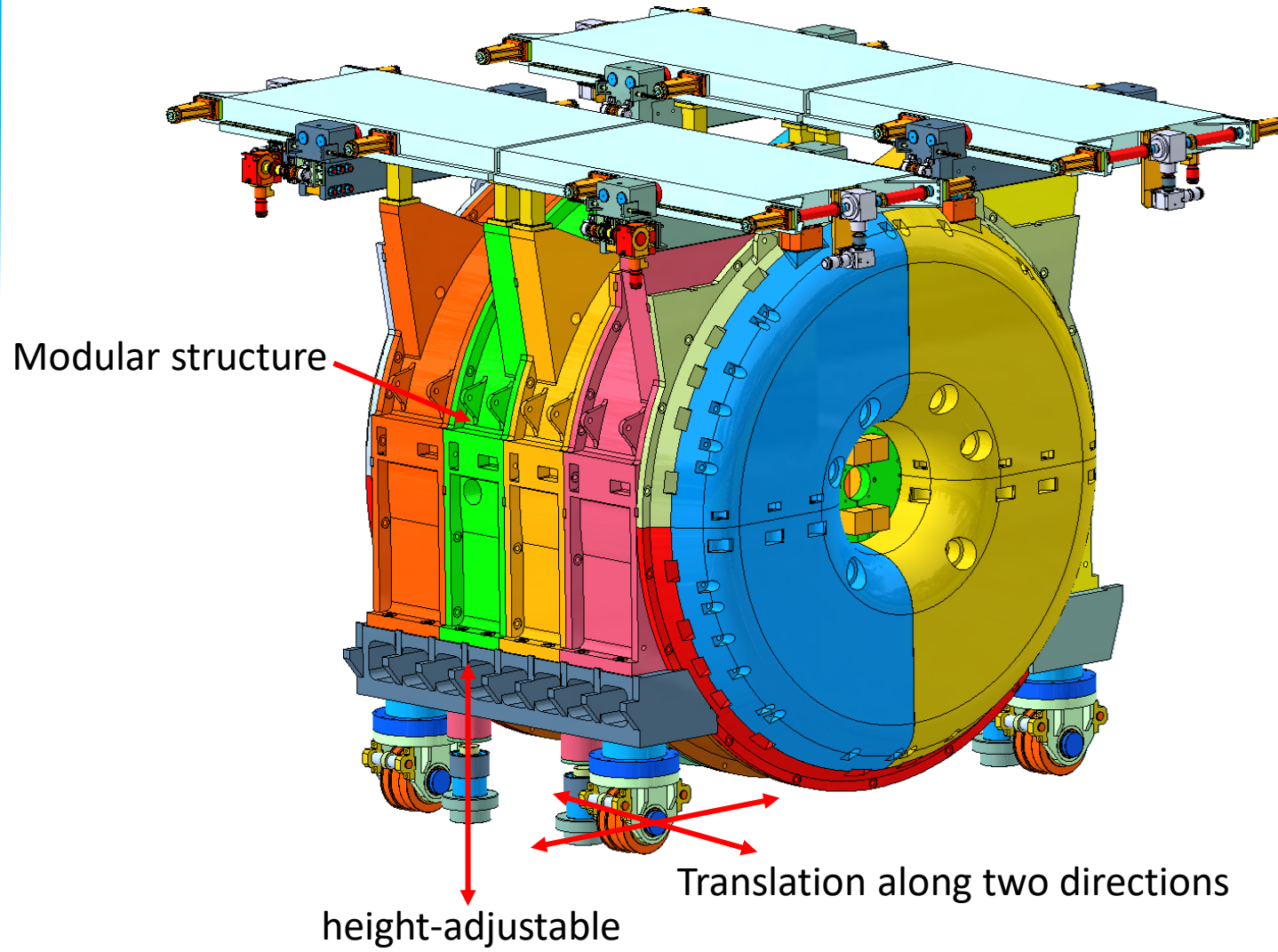

Organization

Organization

SAND Group will put in place a number of hardware experts (engineers/technicians) sufficient to complete the operations in the time allocated in the planning.

The team involved on the dismantling will be composed by:

- Work Package Leader (technical responsible);
- Site Supervisor
- Safety Coordinator (PSCe)
- GLIMOS
- Mechanical technicians (external staff): 3 technicians
- Technicians (INFN): 2 technicians
- Handling Team (external staff): 2 technicians

Name	Role	Organisation
Alessandro Saputi	Work Package Leader	INFN/FE
	Technical Coordinator and Site Supervisor	INFN/LNF
Sandro Vescovi	Safety coordinator	INFN/LNF
Francesco Noto	GLIMOS	INFN/LNS
?	Mechanical technicians	External Staff
?	Technicians	INFN
Ditta Polacchi	Handling team	External Staff

Thank You!!



KLOE Magnet: arrival in Frascati

nil volentibus arduum



Unloading phase

KLOE Magnet: insertion

nil volentibus arduum



KLOE Magnet: handling

nil volentibus arduum

