

# Evaporation Facility at Naples University

F. Di Capua on behalf of Napoli Group

Photon Collector Meeting - 11/06/2024

---



UNIVERSITÀ DEGLI STUDI  
DI NAPOLI FEDERICO II



## European site for PTP wavelength shifting evaporation on Vertical Drift (FD2)

- Evaporation of the **cathode (320 double sided)** and **membrane (320+32 single sided)** XA-VD modules
- Evaporator design inherited from the Campinas evaporation chamber with
- **Relevant improvements:**
  - larger chamber with 120 cm diameter providing **+100% evaporation throughput wrt Campinas evaporator**
  - **multiple crucibles** to assure more uniformity in the coatings and speed up the process
- Pumping system sized to ensure 2 full coating processes/day



## Chamber Design and Production

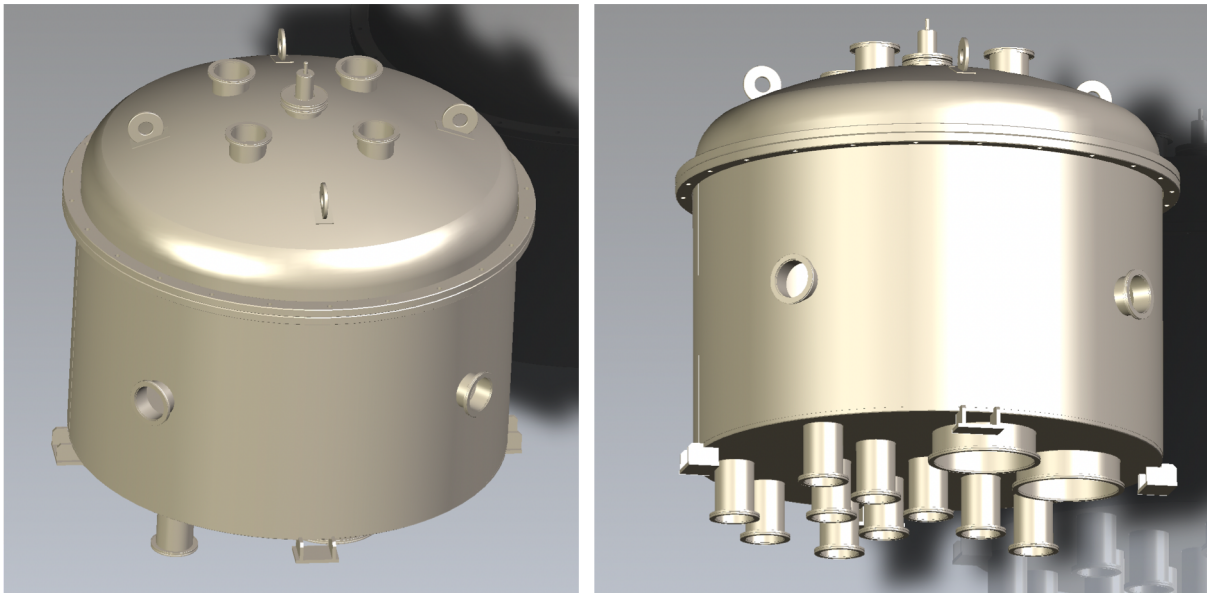

- Chamber already designed and now in production phase
- Several accommodations at the bottom base for crucibles (optimization of the position will be done in commissioning phase)
- Pumping port 250 mm diameter (DN 250 ISO-F)
- Several lateral and top ISO-K 100 flanges
- Pumping station with a 40 m<sup>3</sup>/h and 2300 l/s turbopump Several lateral and top ISO-K 100 flanges
- Motorized system on the top of dome with motion feedthrough to rotate a support structure disk to hold the filters



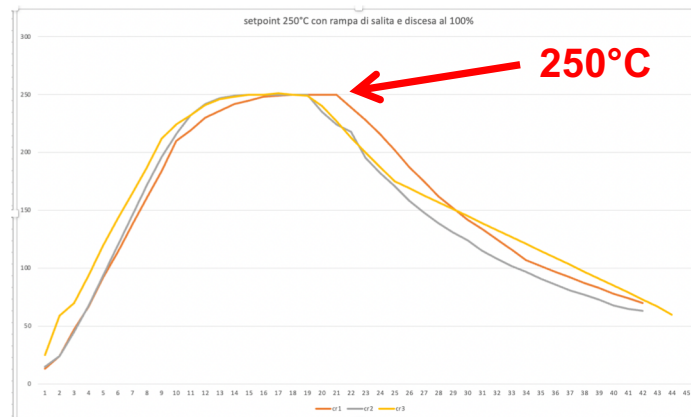
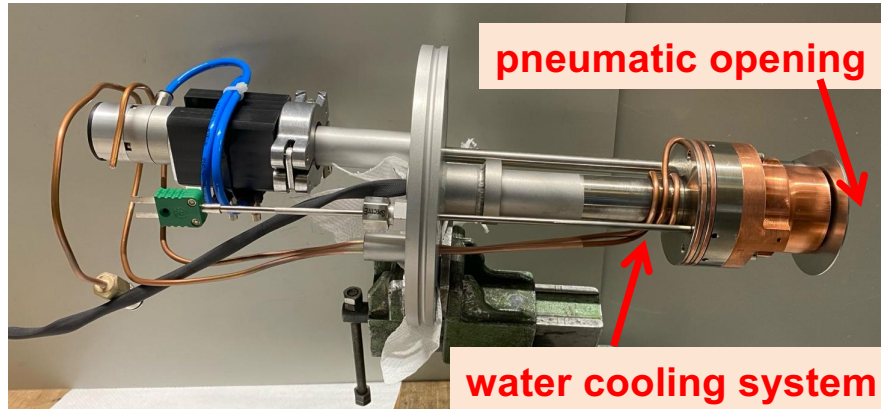

## Crucibles

- Crucibles produced and tested in vacuum
- PID controlled temperature, with a very good set point stability
- Crucible directly mounted in flange DN 100 ISO-K
- Electro-pneumatic opening and cooling system
- Maximum operating temperature 500°C, working temperature at 250-300 °C



## FD2 evaporation site: programming of the operations

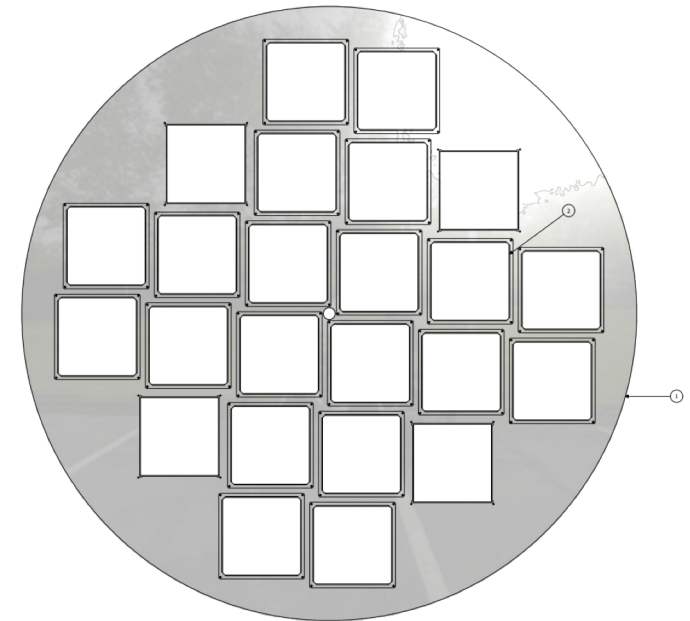
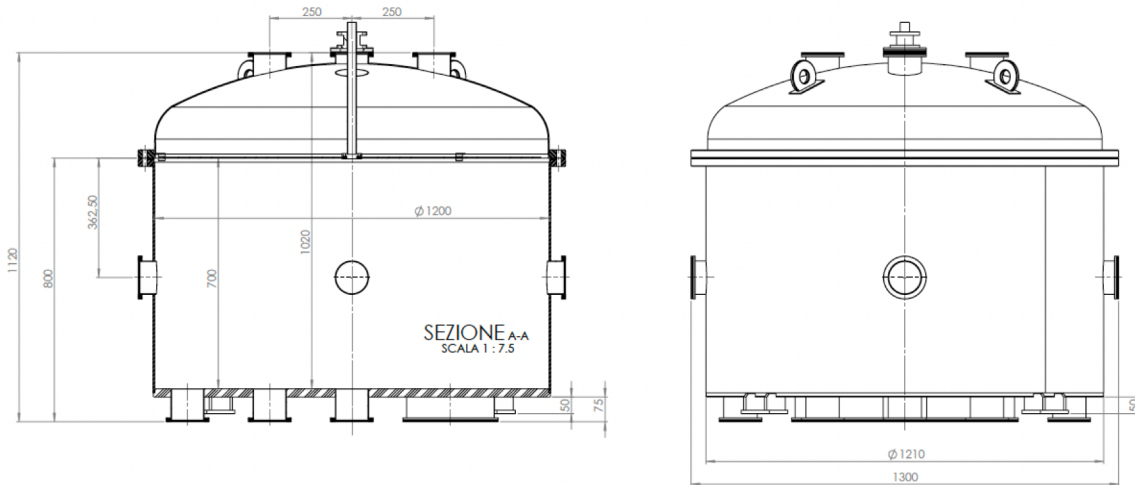

- DF/NF dimension of  $14,4 \times 14,4 \text{ cm}^2$
- Disk holder for filters with 112 cm diameter
- Up to 24 filters for evaporation process can be accommodated



## FD2 evaporation site: programming of the operations

	Number of modules	Number of filters per module	Total number of filters
Membrane modules	352	16	5632
Cathode modules (double side)	320	32	10240
Spares	??	?? 10% ??	750
Total			16622

Duration of whole evaporation process estimated at approximately 4-5 hours

Main steps of the process:

- Measure of mass for each 2 or 3 filters before and after the evaporation
- Filters positioning on the holder disk
- Preparation of the control samples
- Insertion in the chamber
- Vacuum phase
- Evaporation with PTP
- Opening of the chamber and removal of the disk
- Removal the filter and place them in the proper boxes
- Check of the control samples

- 2 shift for day: 8-10 hours
- 48 filters/day
- Required 346 days (about 70 weeks)
- 2 years of operation involving INFN technicians.



UNIVERSITÀ DEGLI STUDI  
DI NAPOLI FEDERICO II





## FD2 evaporation site: dedicated operation tools under development

- Evaporator lab will be completed by Q4 2024
- Commissioning of the system and ready to start by Q1 2025

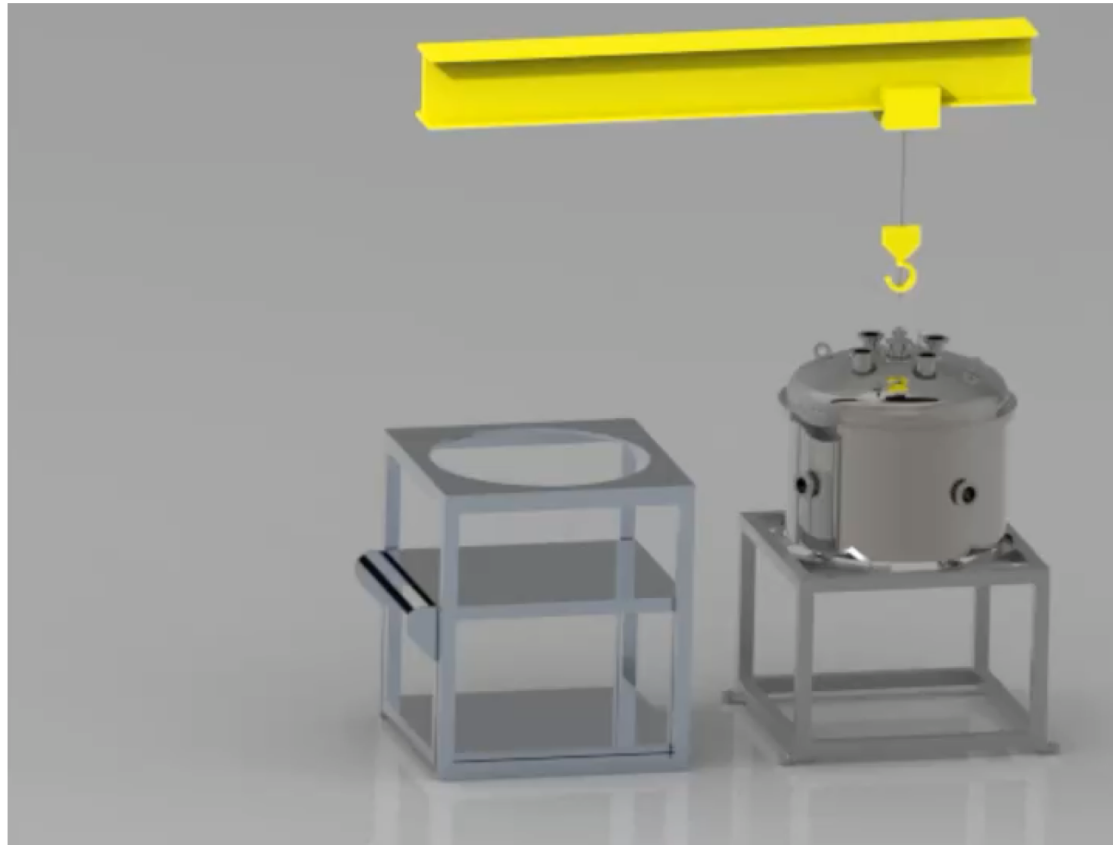

Video made by Heriques Frandini and Ana Machado



UNIVERSITÀ DEGLI STUDI  
DI NAPOLI FEDERICO II



## Logistic to be defined

- **Type of filters** (dichroic or neutral) to be coated needs to be defined after CIEMAT measurements
  - CIEMAT results in 1 month from now
  - verify and confirm with ProtoDUNE run
  - Verify with the pre-production schedule
- **Specify** which type of substrates and from which Institute(s)
  - Indication of failure due from fused silica substrate/polishing
  - Indication of failure from cold box, no indication of damage at CIEMAT
  - Perform more test
- **Define** the packaging and shipping process for the DF/NF to organize the storage space needed at the evaporation site.
- Coated filters should be accommodated in dedicated shipping boxes. Define **who will design and produce** the boxes and determine the quantity needed.
  - Carla (MIB): possibility to produce up to 200 boxes in MiB mechanical workshop
- Each box should contain the number of filters of **1 or 2** evaporation batches (24 or 48 filters)
- Boxes with the evaporated filters should be shipped: establish if to Integration sites or directly to SURF
  - CIEMAT never considered to mount evaporated filters at integration site
  - A clean environment needed at SURF-→ Dave W. communicate that a clean room class 10000 is available at the shaft level
- Set a **strategy** to **reduce** the number of **boxes** to be produced: they can be **shipped back** while the filters are mounted on the PDS modules
- **Documentation** about filter coating, storage, filter travels need to be agreed among all the different evaporation DUNE center sites (Naples, Campinas and third possible one)

