

TMS Review: Front End System Configuration and Powering

Vittorio Paolone



Feb. 7, 2025

TMS Detector and Readout Preliminary Design Review

Outline

- General Electronics Overview
- Grounding
- LV Power
 - Requirements, voltage drops, and cabling
- Signal Cables
 - Requirements
- FEB Mounting
 - Routing
 - Fringe field Considerations
 - Enclosure Boxes Details
- Prototyping Goals

Electronics Grounding Scheme:

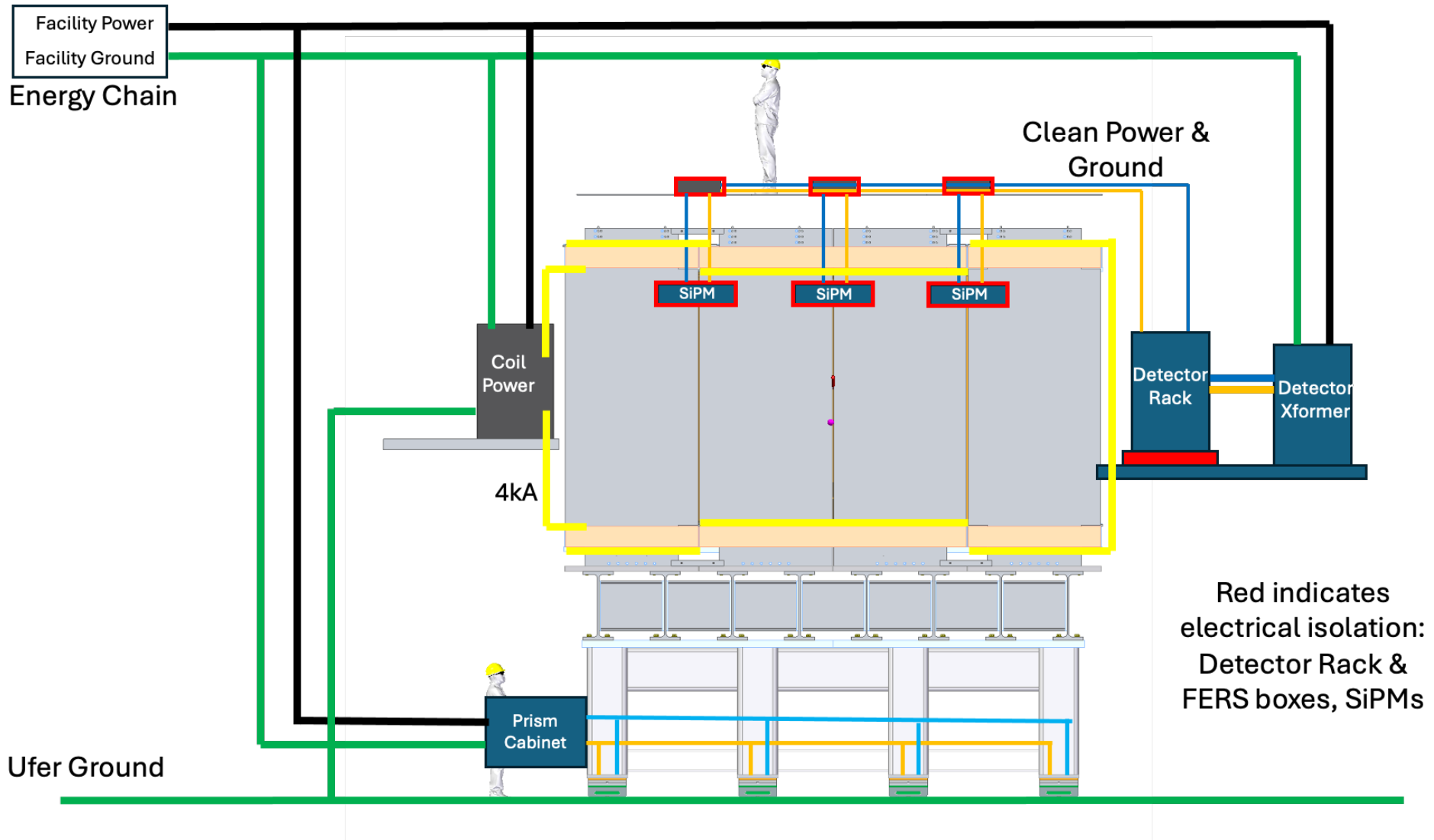

Electronics Grounding Scheme:

- TMS Support steel, TMS Magnet steel, TMS detector mechanical components are all on facilities ground, delivered through the coil and detector power cables on the energy chain. This may need to be augmented with physical additional connections to “Ufer Ground”.
- Mezzanines that support the coil power supply and the racks holding detector LV are also on building ground.
- Detector power will go through an isolation transformer.
 - The detector rack housing the readout LV system, data concentrators, ethernet switches, etc. will be electrically isolated from its mezzanine and powered and grounded by the secondary circuit of the transformer.
 - The ≥ 51 metal boxes that will each house 6 CAEN A5202 Front End Readout boards will be electrically isolated from the facilities ground and connected to cables from the LV power supplies (Detector Power and Detector Ground).
 - The 10-wire micro coax ribbon readout cables will provide HV ($\sim 60\text{V}$) and detector ground to the SiPM PCBs. The SiPM PCBs will be electrically isolated from the detector and cassette metal parts.

FEB Power Requirements

- The power requirement per 64 channel CAEN 5202 FEB is 750 mA @+12 V,
 - 9 W: acquisition on, all channels enabled, HV on, 64 SiPMs mounted.
- To readout a total of 19200 channels, 300 CAEN 5202s are needed
 - Total FEB power requirement of ~ 225 A @+12V, or ~ 2.7 kW.
- The candidate power supply system is the Wiener PL512 Power Supply with 6 7V-16V 2 +/- 23A / 250W modules.
 - Each module has two channels for a total of 12 LV channels per PS unit.
- Each FEB Enclosure Box(EB) will house 6 FEBs and therefore will require a total of ~ 60 W.
 - Conservatively up to 2 EBs can be daisy chained to the same PS channel

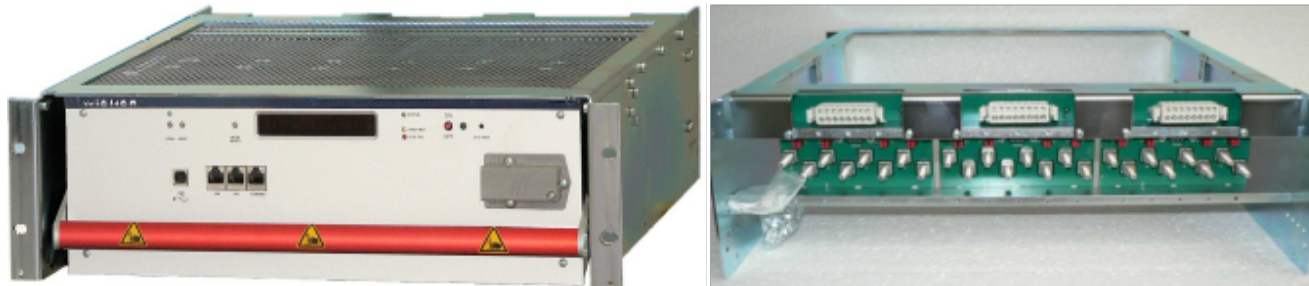

FEB Power Cabling

Power Cable Belden 500UP Voltage Drop Estimate

- Each FEB Enclosure Box(EB) will house 6 FEBs and therefore will require a total of ~60 W.
- Conservatively up to 2 EBs can be daisy chained to the same PS channel 12 FEBs @+12V drawing 9 amp (Inner conductors 12 AWG – 20 amp current limits)
- For the BELDEN 500 UP Cable DCR @ 20° C: 1.56 Ohms/1000 ft. To limit Voltage drop to 3 Volts (i.e. 16V-3V = 13V) need to limit power cable length from PS to EB to 214 ft (65 meters). This number assumes daisy changing 2 EBs could double maximum length (130 meters) if powering only 1 EB/PS channel
- Assuming a total of ≥ 51 EBs for complete readout and 2 EBs per PS channel
 - Each PL512 has 12 PS channels: We'll need 3 (6 if 2 EBs are not daisy chained) Wiener PL512 systems
- ELECTRONIC RACKS
 - Assuming a standard EIA width rack all Wiener PL512 systems (3) can be mounted in a single rack. In addition, all CAEN DT5215 (~5 units) Concentrator Modules can be mounted on a shelf in the same rack. The rack can be located in the mezzanine assuming all power cables (BELDEN 500UP) to the EBs never exceed 65 meters.

Signal Cables and Cable Routing

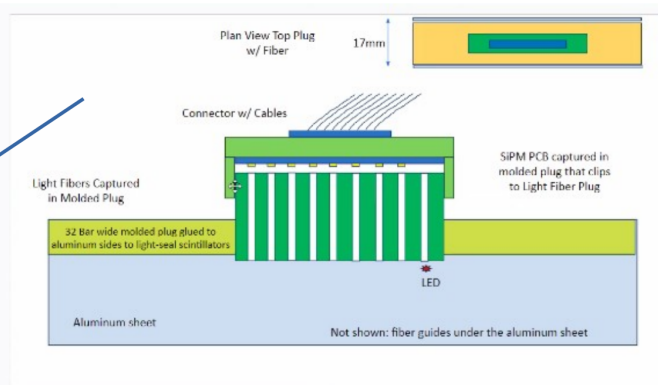
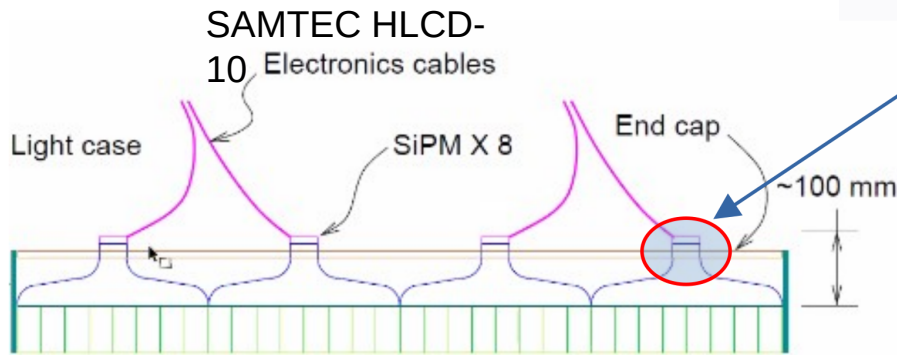

- Shown above is a drawing of a 32 channel scintillator module with four snouts and cable connections.
 - A TMS scintillator plane (both Vertical and Horizontal) is constructed of 6 modules for a total of 192 channels.
- Each snout services 8 scintillator bars/SiPMs and at the end of the snout
 - A PCB board is attached with a surface mounted connector
- (20 conductors, SAMTEC LSHM-110-02.5-L-DV-A-S) for the 10 coax channel ribbon cable SAMTEC HLCD-10



- Only 8 of the 10 coax cables will be used for the SiPM channels.
 - The remaining 2 channels will be used for LI LED supply and control and temperature sensor readout.
- Since each module consists of 32 channels 4 SAMTEC HLCD-10 cables will be needed for each module.
- The full TMS consists of 100 planes of 6 modules each (19200 SiPM channels in total).
- Since each module requires 24 cables the total number of HLCD-10 cables needed is 2400

Cables and Cable Routing cont.

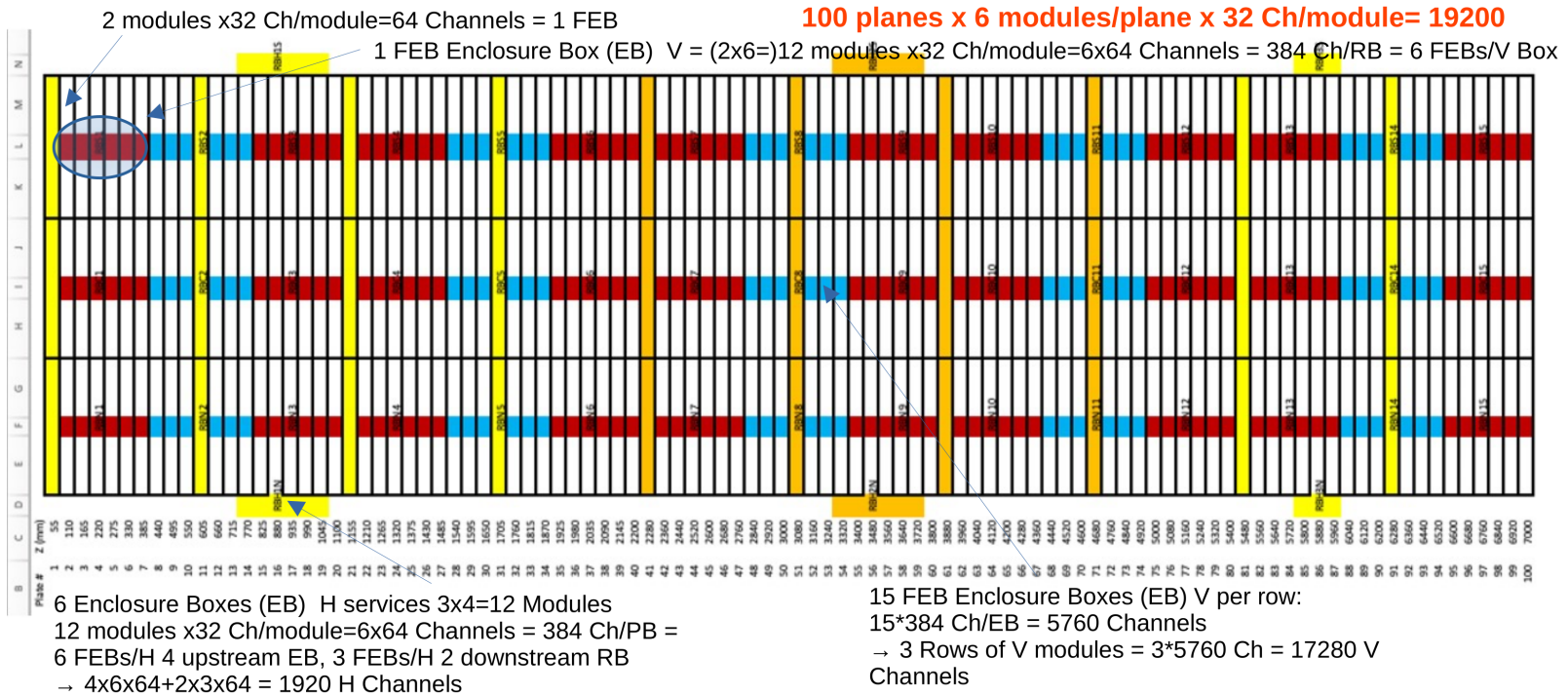

- The proposed location of the FEB (CAEN 5202) Enclosure Boxes (EB) are shown above
 - The locations were chosen to minimize cable (SAMTEC13 HLCD-10) lengths
- For the Vertical (U-V orientations) modules the scintillator snouts are oriented vertically and the readout cables then route directly to the bottom connectors of the TOP mounted enclosure boxes.
 - The number of cables needed to service the 90 Vertical planes is 2160 at a length of *3-4 meters(more later)*.
- The 10 Horizontal(H) counters are uniformly spaced throughout the detector.
 - These H counters are serviced by FEB Enclosures mounted midway on the vertical sides of the TMS since the module snouts for these counters exit the sides.
- The number of cables needed to service the Horizontal planes is 240 at a length of 3 meters.
 - This length could be reduced if needed by increasing the number of enclosure boxes.

Enclosure Box (EB) and Cable Routing: Fringe Field Considerations

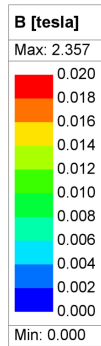

200 gauss

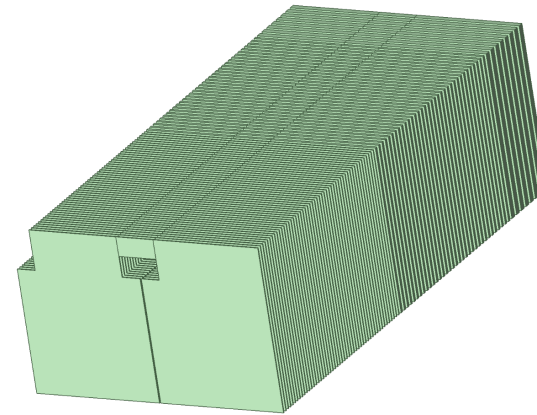
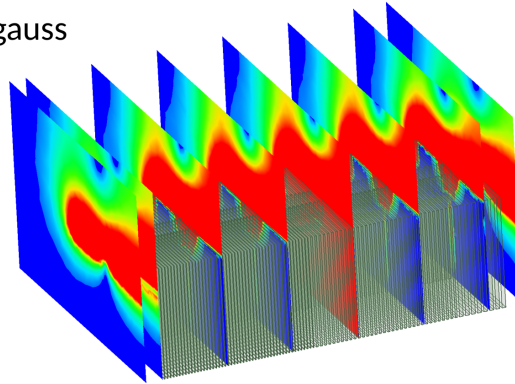

M. Oriunno/SLAC

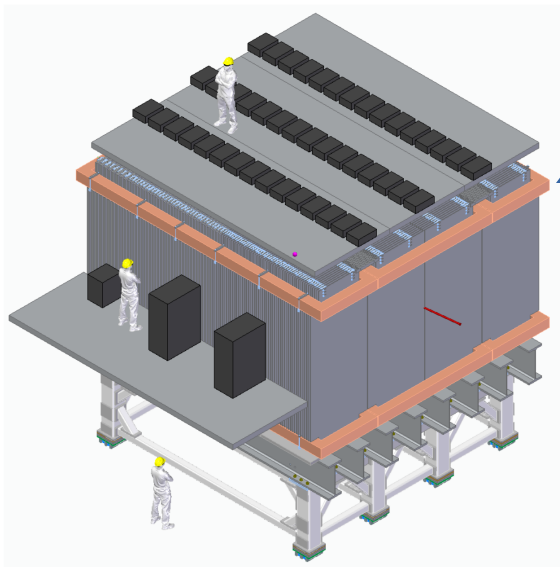
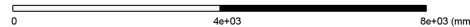

Depending on how much the fringe field affects the performance of the CAEN 5202 FEBs will determine the final length of the signal cables and how high the EB mounting platform will need to be placed above the surface of the TMS

→ Testing the FEBs in a B field is a top priority of the LSU test-stand program

FEB Enclosure Boxes

Enclosure Box Model:
~300 mm(L) x 200 mm(W) x 400 mm(H)

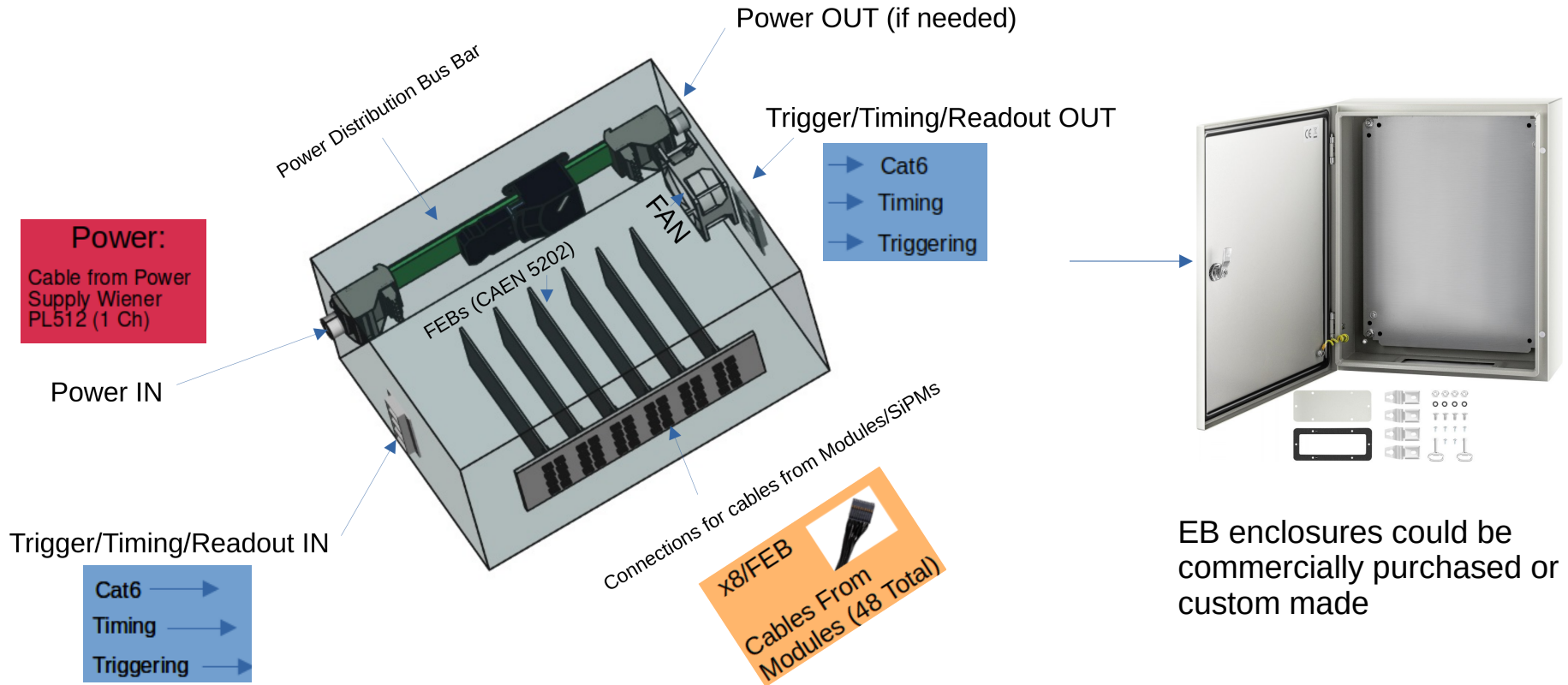

EB enclosures could be commercially purchased or custom made

- FEB Enclosure Box showing power, signal, and control connections.
- Each FEB Enclosure services 6 CAEN 5202 FEBS and is ~40 H x 20 W x 30 L cm³

FEB Enclosure Boxes cont.

- A minimum of 51 FEB Enclosure Boxes(EB) (45 for U/V and 6 for H planes) will be needed for the TMS.
 - Each EB contains 6 CAEN 64 channel 5202 FEBs with dimensions $\sim 50 \text{ H} \times 20 \text{ W} \times 50 \text{ L cm}^3$.
 - The box material is expected to be made of metal to help shield from RF noise.
 - The boxes will either be custom made or purchased commercially.
 - 384 SiPMs will be serviced by 1 EB when fully occupied (6x64).
- One SAMTEC HLCD-10 cable services 8 SiPM channels (both signal and HV) each FEB will have 8 cables connected to its input via a custom PCB with 8 surface mounted SAMTEC LSHM-110-02.5-L-DV-A-S receptacle female connectors.
 - A maximum of 6 FEBs will exist in a EB up to 48 SAMTEC HLCD-10 cables will be connected to a single EB.
- In addition to connections for the signal inputs the EBs will supply the LV for the FEBs and the required daisy chained optical fibers to the Concentrator Boards, timing and triggering cables via INPUT and OUTPUT patch panels accessed from the outside of the Ebs.
- Cooling of the electronics will be achieved by the use of fans installed on the inside of the Enclosure Boxes.

Electronics Mounting to Magnet

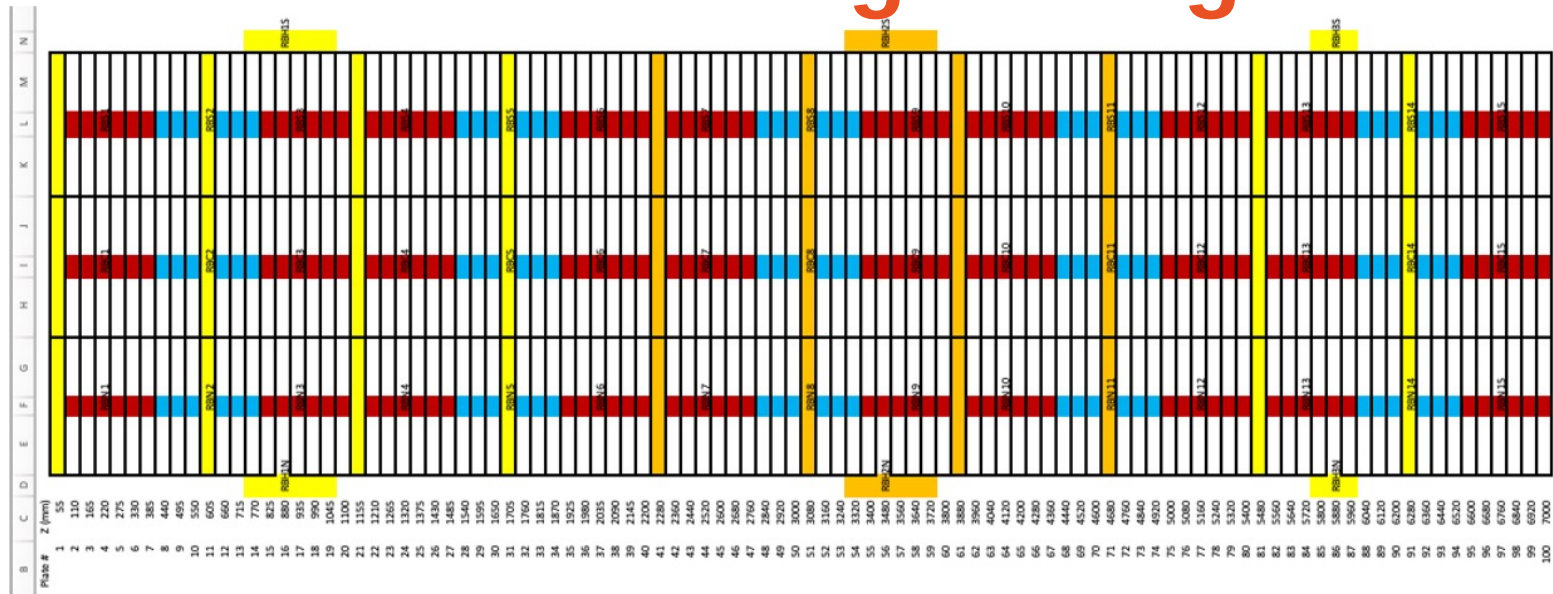

- The proposed locations of the FEB Enclosure Boxes (EB) servicing the U/V planes are shown above (red/blue rectangles).
 - For the the Vertical planes 15 Enclosure Boxes(EB) are mounted on the top of the TMS in three rows labeled North, Center, and South for a total of 45 EBs.
 - Each EB has the following dimensions, 50 H x 20 W x 50 L cm³ and weighs ~10 kg.
- The total load on the top of the TMS from the electronic enclosures is ~450 kg uniformly distributed along the length (z, beam direction) of the detector.
 - A simple rail system is expected to be attached to the top of the TMS to which these boxes will be bolted.
- The 6 (or more) remaining EBs servicing the Horizontal modules would be attached to the side face (both sides, 3 on each side) of the TMS via mounting brackets bolted to the steel plates.

Data Transfer Cabling:

(Block diagram of the CAEN DT5215, TDlink and A5202 unit connections (from CAEN catalog).)

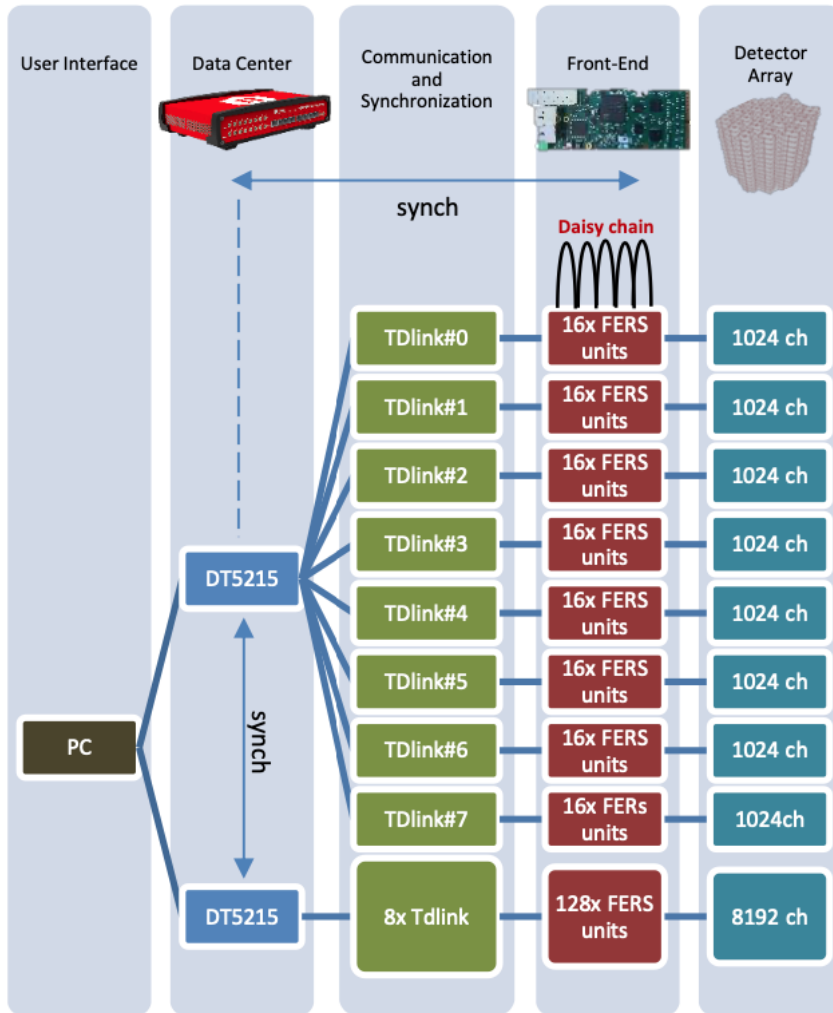

- The data cables connected to the Enclosure Boxes will be industry standard:
 - Fiber optics cables with LC connectors for the data transfer to the Concentrator Boards
 - RG178 50Ω cables for both the timing and trigger signals via standard LEMO connectors on the Enclosure Box patch panels to the FEBs.

Power/cabling/enclosure Prototyping

- Electronics Power Distribution to Readout Test-stand
- To be located at the University of Pittsburgh
 - Includes:
 - Testing/design/construction of CAEN 5202 (FEBs) Enclosure Box
 - Power consumption, connections and internal distribution
 - Cooling
 - Cabling/connectors from module snout to input of FEBs
 - Cabling of trigger and timing

Backup