



Overview of Present and Future Laser Diagnostics for Fermilab H- Accelerators

Vic Scarpine, Fermilab
Presenting for the H- laser
diagnostics team



Booster/Linac Laser Profile Monitor

Booster Laser Profile Monitor (LPM)*

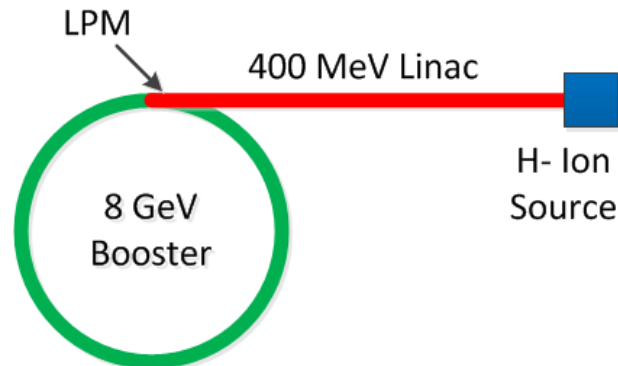

* Courtesy of Dave Johnson et al.

- $I_B \sim 35$ mA
- Pulse rate up to 15 Hz
- 200 MHz bunching
- $\sim 1e9$ H- per bunch

- Utilize photons from Nd:YAG laser ($\lambda = 1064$ nm) to photodetach the outer electron from the H- ions creating neutral H0 atoms and free electrons.
- For a 50 mJ 10 ns laser pulse with an average laser size of 200 μ m, we neutralize about 92 % of the H- passing through the laser.
- The liberated electrons are swept into electron detector by weak magnetic field.
- With a laser beam diameter \ll H- beam, we can scan the laser across the H- beam and collect the electrons at each position of the scan thus giving us a density profile of the H- beam.
- For typical source currents of ~ 35 mA \rightarrow 200 MHz bunch intensities of $\sim 1E9$ with a bunch separation of ~ 5 ns. For a laser pulse duration of ~ 10 ns we impact only a single bunch each linac cycle.

Fermilab LPM

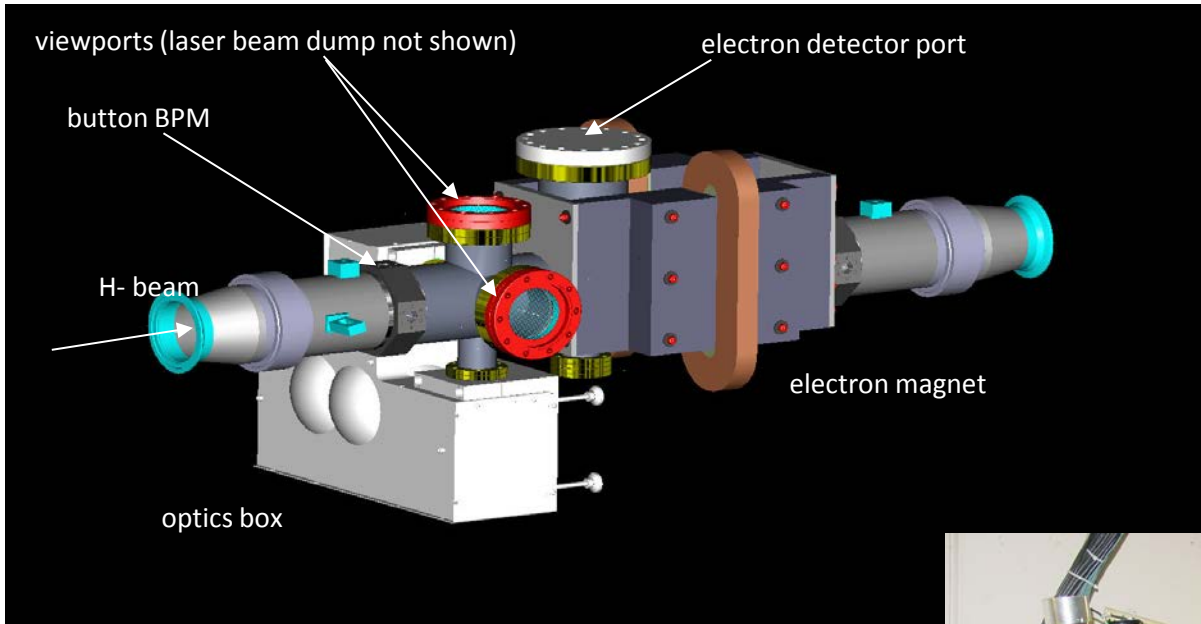

Installation in Booster

- Nd-YAG Laser far from LPM
- Reduce Booster radiation effect
- Long transport – difficult alignment

- Q-switch laser
- Laser energy: ~ 50 mJ/pulse
- Wavelength: 1064 nm
- Pulse length: 9 nsec
- Pulse rate: 20 Hz
- Fast rotating mirrors ($\pm 4^\circ / 100$ μ sec)
- e^- detector

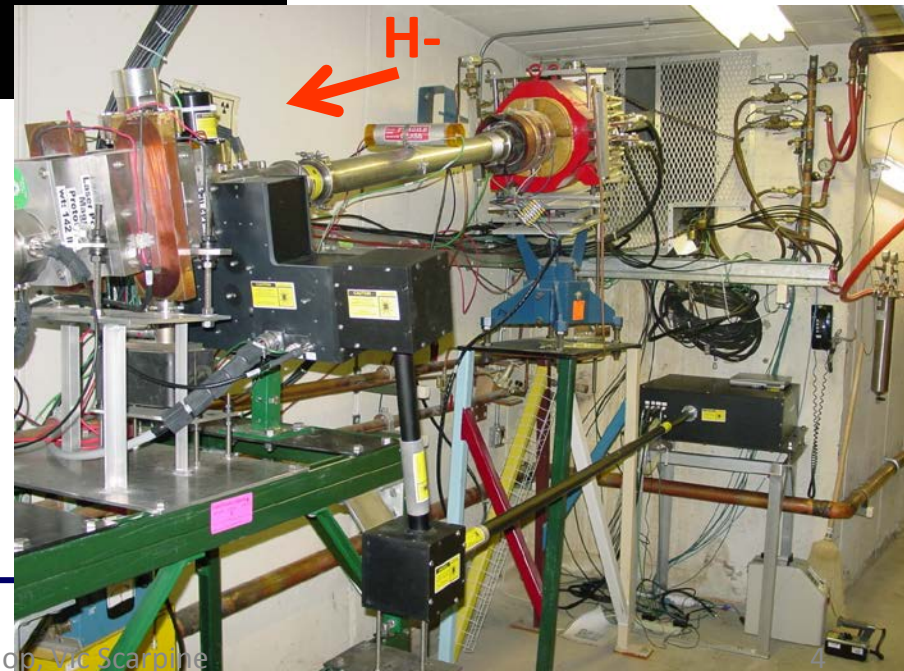

LPM Laser Paths

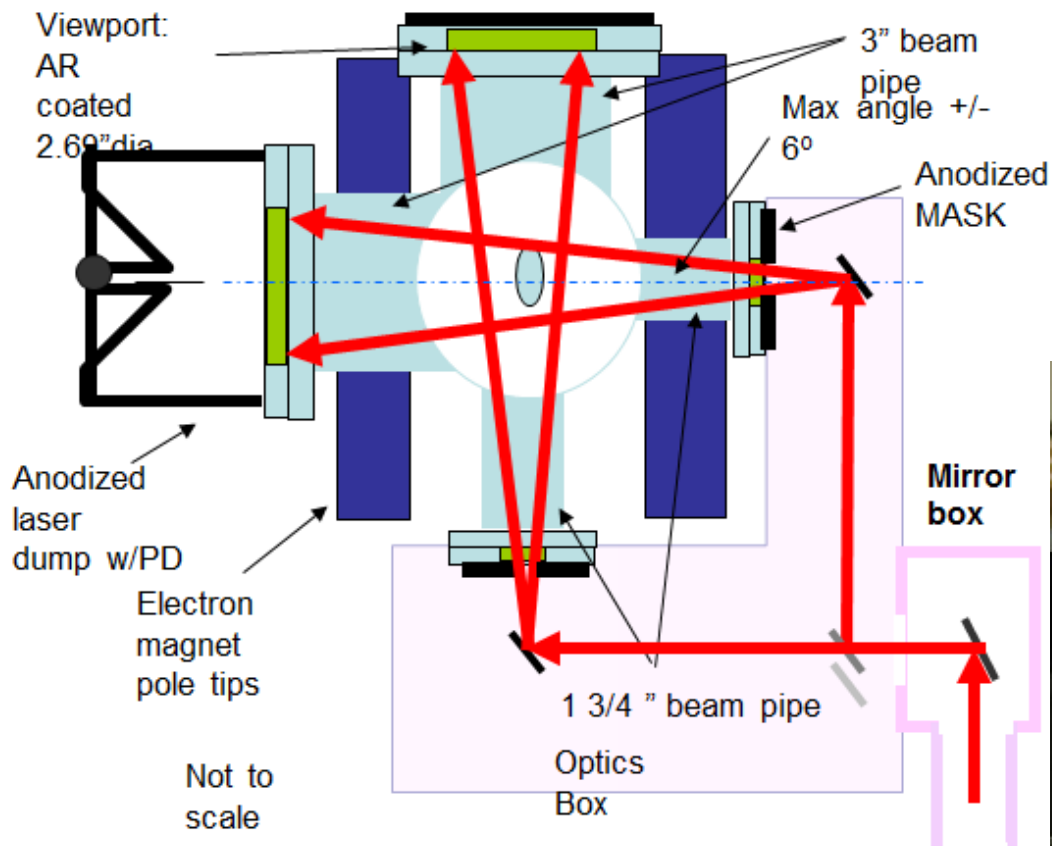

Optics Box

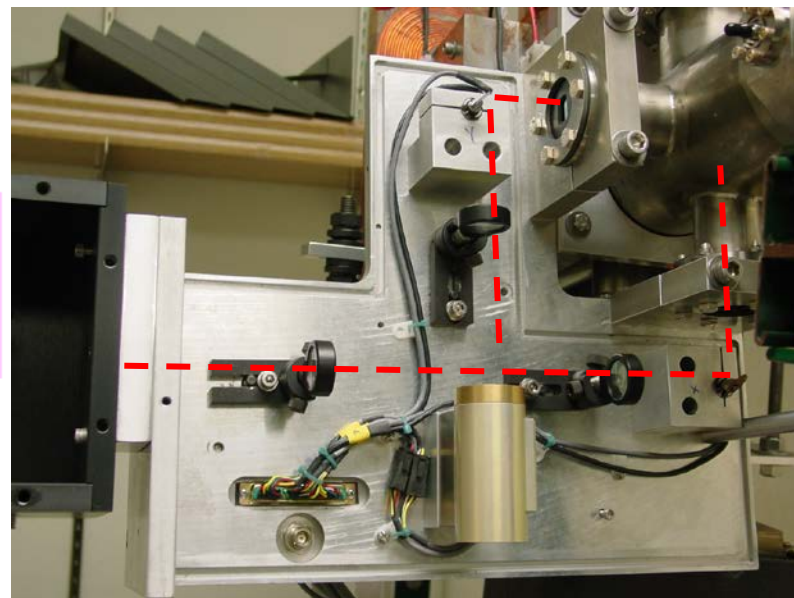

LPM Cross Section

LPM Profile example

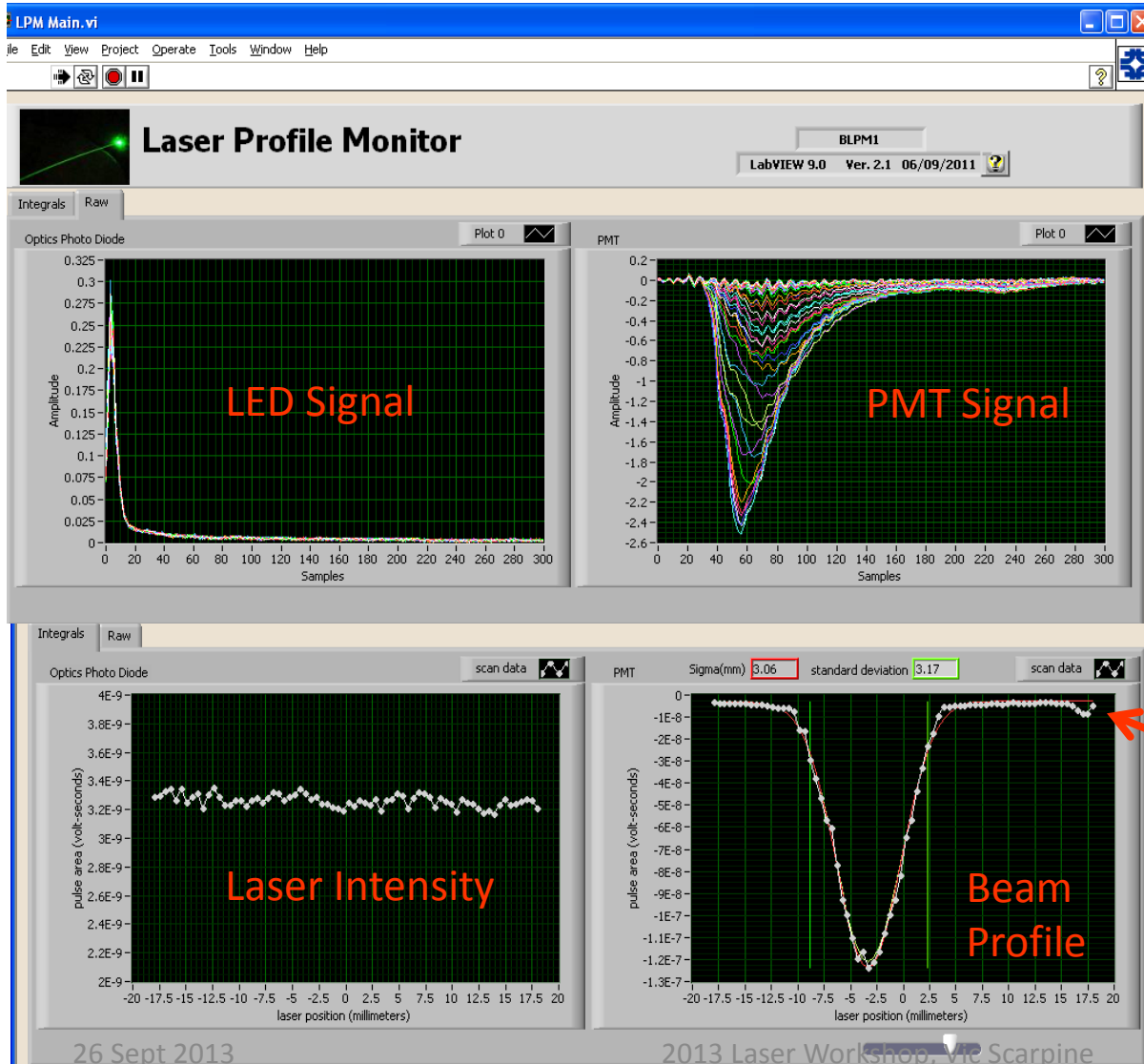

Bunch intensity $\sim 1E9$

Scan range -18 to 18 mm

PMT HV 700 V

72 data points across scan
10 beam samples/data point

Is this real beam or reflection?

Small peak area $\sim 2.3\%$
of Main bunch

LPM Issues and Status



Hardware Issues

- Laser power supply damaged by radiation
 - Moved power supply up stairs
- Scanning galvanometers issues
 - Optical position feedback loop maxed out voltage
 - Suspect darkened led – working with vendor

Status

- Coming out of 1+ year shutdown – beam is back
- Data analysis resuming
- Need to further optimize the laser energy/timing, PMT high voltage, and better understand the PMT signal and ADC optimization



Laser Diagnostics for Fermilabs Future Accelerators



The goal is to construct and operate the foremost Intensity Frontier facility in the world.

- A neutrino beam for long baseline neutrino oscillation experiments
- MW-class low-energy proton beams for kaon, muon, neutrino, and nuclei/ nucleon based precision experiments
- A path toward a muon source for possible future Neutrino Factory and/or a Muon Collider

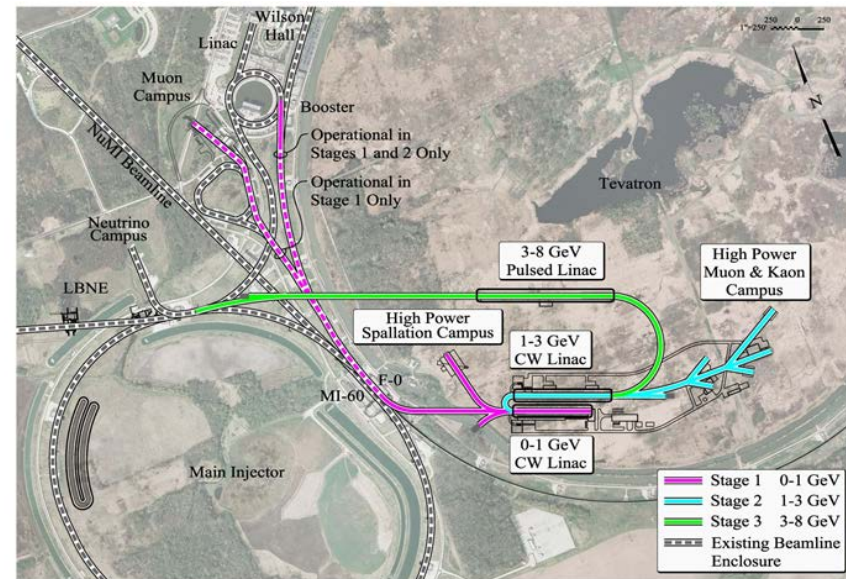
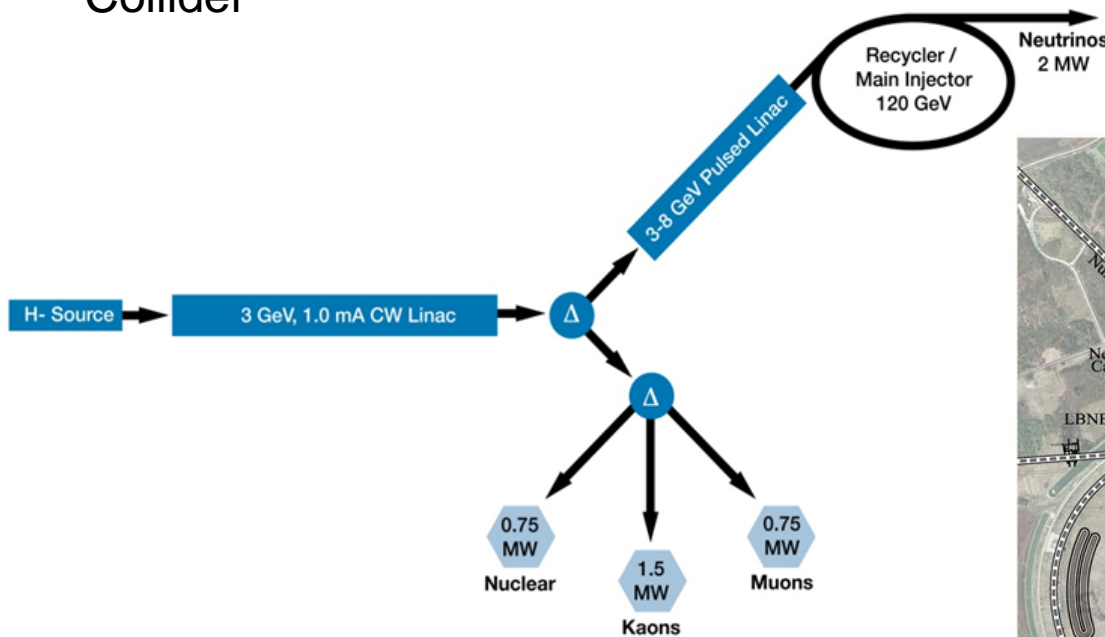



- Beam current
 - DCCTs, Toroids, High-Bandwidth Resistive Wall Current Monitors (RWCM)
- Beam position and phase
 - Warm and cold BPMs
- Beam energy and energy spread
 - Time-of-flight from BPM phase, spectrometer magnet
- Beam transverse profiles
 - Wire scanners, multi-wires, *laser wires*
- Beam transverse emittance
 - Allison scanner, slit-wire scanners, *laser emittance monitor*
- Beam longitudinal profiles
 - Wire-based bunch shape monitor, *picosecond laser wires*
- Beam halo
 - Vibrating wire, high-gain wires, *laser wires*, apertures, diamond detectors
- Beam loss monitoring
 - Ion chambers, neutron detectors
- Chopped beam extinction efficiency
 - High-Bandwidth RWCM, single (few) particle detection

List of ~ 15 unique instruments needed for Project X



Build an integrated systems test of the first ~ 30 MeV of Project X

- Validate front-end concept to minimize technical risk elements
- Demonstrate wideband chopper
- Low- β superconducting acceleration

Integrated systems test goals:

- 1 mA average current with 80% chopping of beam in MEBT
- Efficient acceleration with minimal emittance dilution

The scope of beam diagnostics are to identify and provide the instrumentation systems necessary to successful commission, characterize and operate PXIE and to validate the system test goals.

Development and testing of H- laser diagnostics

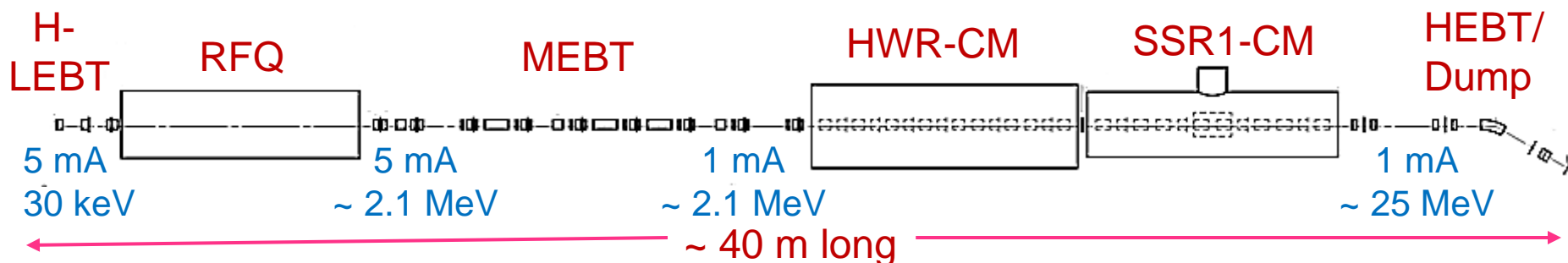

- CW H- source delivering 5 mA at 30 keV
- LEBT with beam pre-chopping
- CW RFQ operating at 162.5 MHz and delivering 5 mA at 2.1 MeV
- *MEBT with integrated wide-band chopper and beam absorbers capable of generating arbitrary bunch patterns at 162.5 MHz, and disposing of 4 mA average beam current*
- Low beta superconducting cryomodules: 1 mA to ~25 MeV
- Beam dump capable of accommodating 2 mA at 25 MeV (50 kW) for extended periods.
- *Associated beam diagnostics*, utilities and shielding

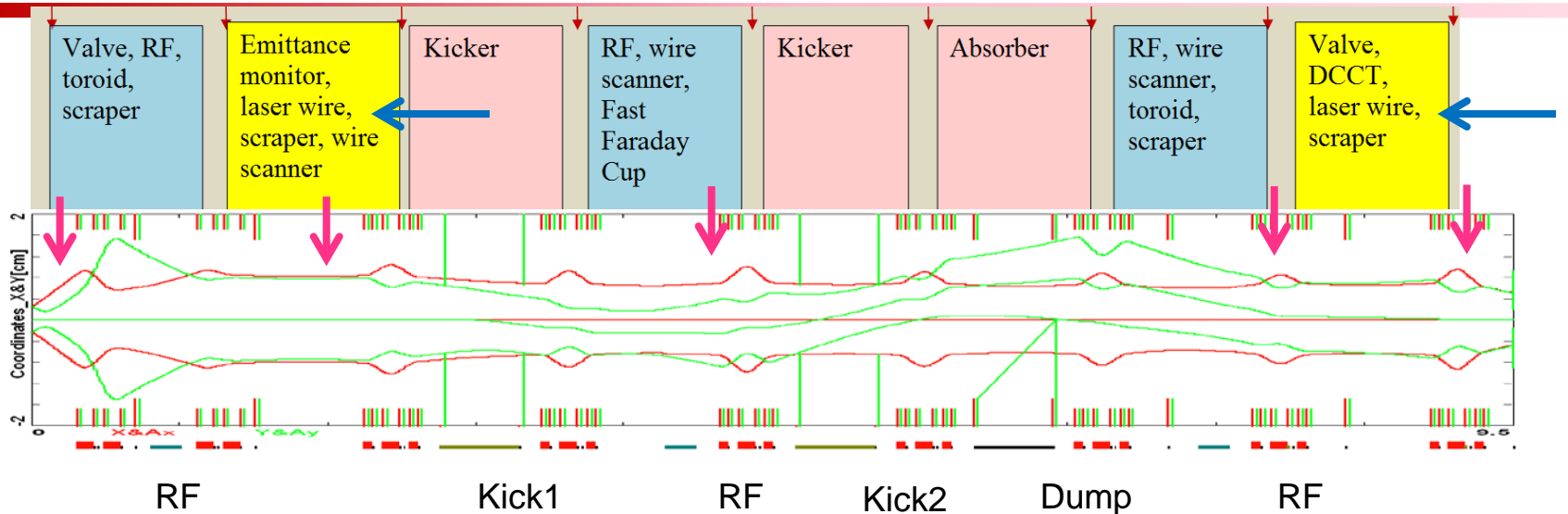

MEBT Operational Beam Measurements: (red = CW)

- Transverse position - BPMs
- Bunch Phase – BPMs → time-of-flight → beam energy
- Beam Current – DCCT, Toroids, RWCM (resistive wall current monitor)
- Extinction – RWCM with fast scope
- Transverse shape – wire scanners, laser wires ←
- Transverse emittance – slit/multiwire (low-res), double slit/Faraday cup (hi-res), Quad scans
- Longitudinal shape – laser wires, chopper, wire bunch shape monitor ←
- Absorber Profiler – OTR Imager or IR imager



Laser Transverse Emittance Monitor

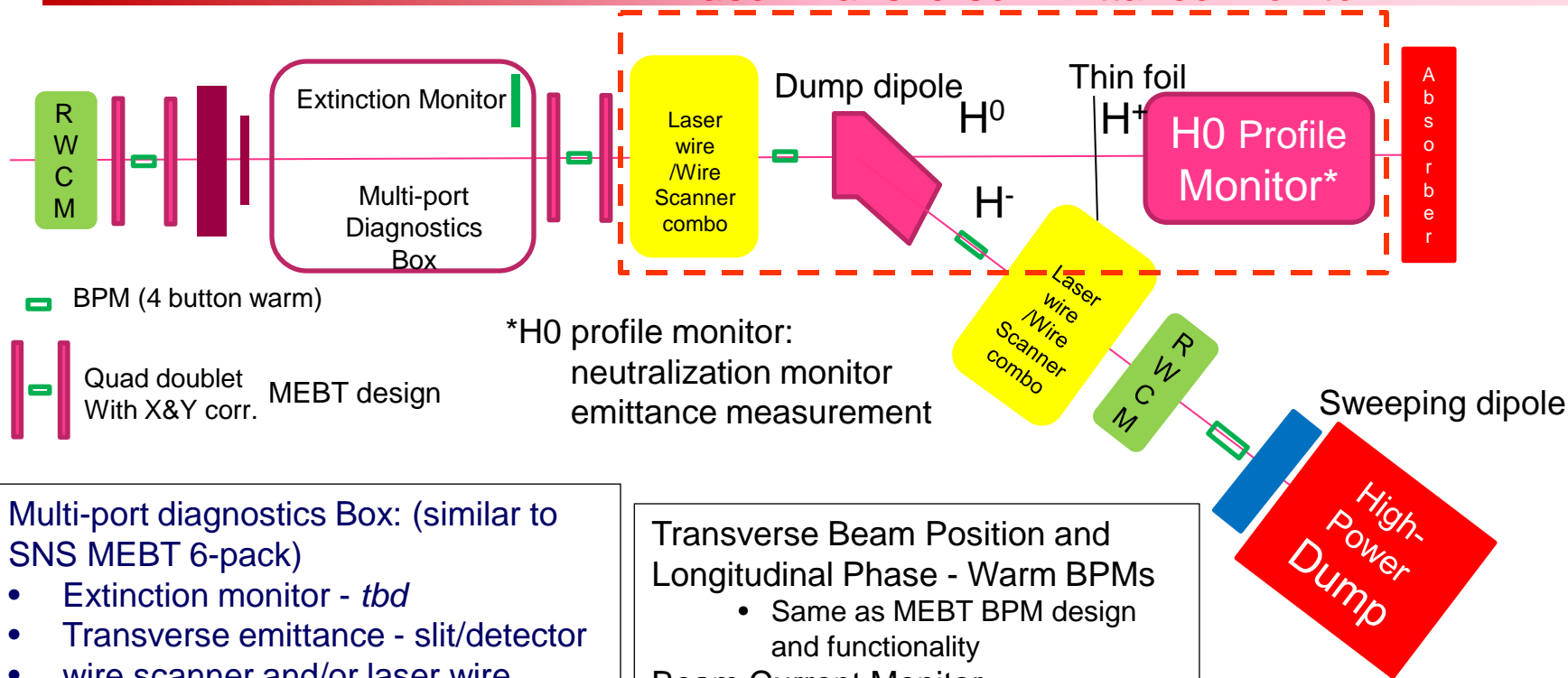

Multi-port diagnostics Box: (similar to SNS MEBT 6-pack)

- Extinction monitor - *tb*
- Transverse emittance - slit/detector
- wire scanner and/or laser wire
- halo monitor – *tb*
- Longitudinal bunch shape monitor
 - Laser wire
- *future “unknown” diagnostics*

Transverse Beam Position and Longitudinal Phase - Warm BPMs

- Same as MEBT BPM design and functionality

Beam Current Monitor

- Two RWCM – like MEBT

Profiles in dump line to measure energy spread

Up to 30 kW of CW H- beam power



Transverse 3-wire wire scanner plus laser wire module

- Hybrid wire scanner with laser ports
 - Modified version of SNS design
- Wire scanner in pulsed beam operation only
- Laser wire in either pulsed or CW beam operation
- Laser wire intended to measure transverse and longitudinal profiles
 - *Will different lasers be required for transverse versus longitudinal measurements?*
- Can wires or lasers measure profile tails/halo?
 - Transverse halo measurements with wire suffer from cross-talk
 - Halo measurement with laser suffer from scattered light effects

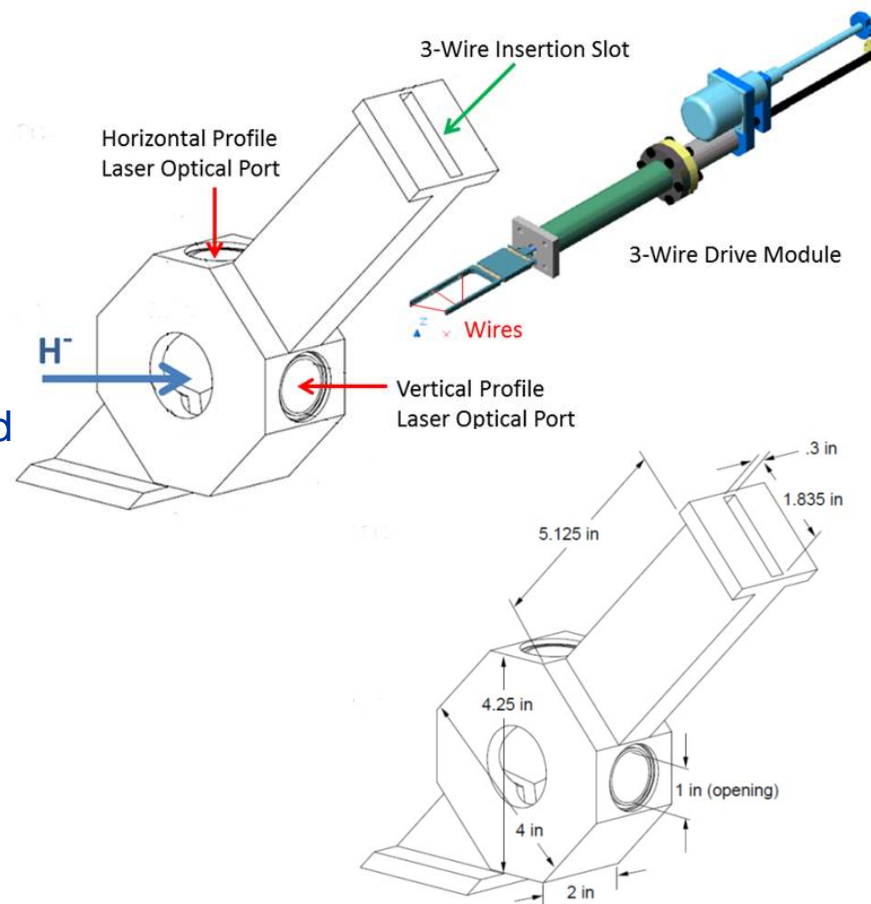

Locations: MEBT, between SC cryomodules, HEBT

Low-Power Transverse and Longitudinal Laser Wire



Mode-locked psec laser used to measure both transverse and longitudinal profiles

- Laser rep-rate is locked to accelerator RF
- Distribute modulated laser pulses via fibers
 - Narrow-band lock-in amp detects modulated signal
- Measure profiles by either:
 - Collection of electrons
 - Use BPM as notched-beam pickup would allow laser monitor to fit between cryomodules

Questions:

- What is the photodissociation efficiency?
- What are the noise issues?
- What are the nonlinear limits to power in the fiber?
- What signal-to-noise ratios and averaging times are practical?

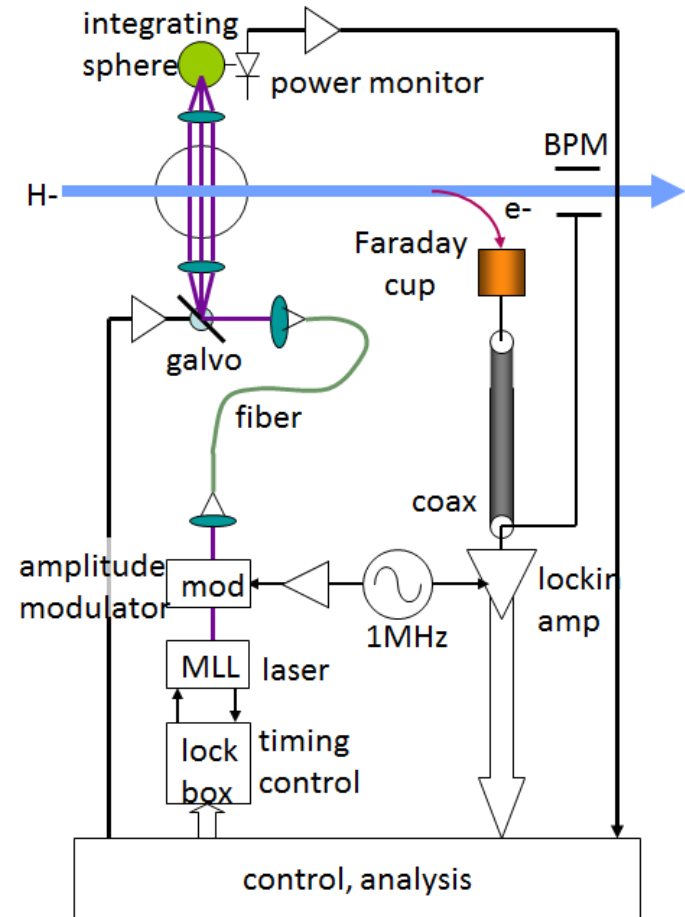

10/27/2011

R. Wilcox, LBNL

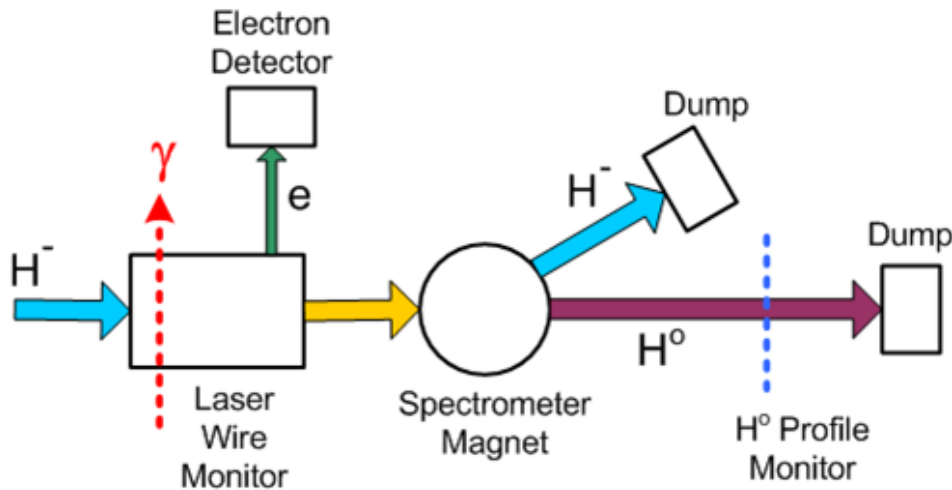

Preliminary SNS Measurements (Y. Liu)

Horizontal

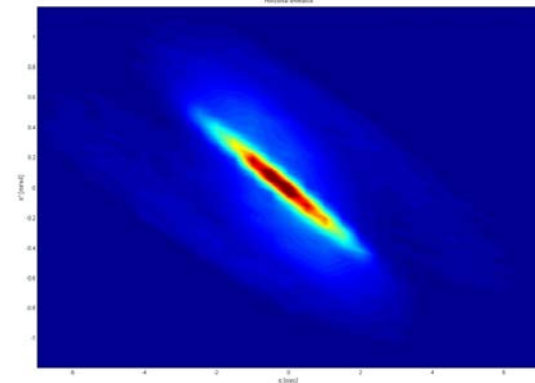

Vertical

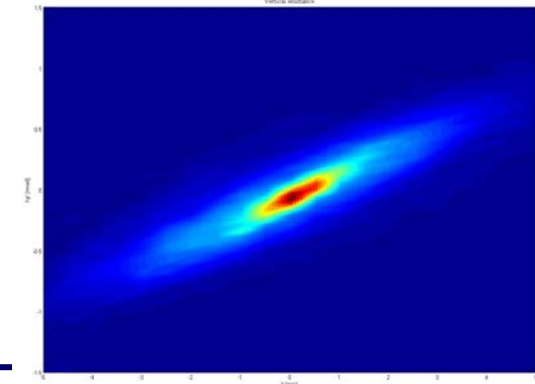

Laser Wire Emittance Monitor

- Laser acts like slit $\rightarrow x$
 - Generates H_0
- H_0 profiler measure H_0 divergence $\rightarrow x'$
 - Background from beam neutralization
- Demonstrated at SNS →

Operate at the end HEBT

R&D Laser Lab



Development of a laser lab for R&D laser work

- Interlocked room
- Temperature controlled
- Class IV laser operation
- Three optical tables

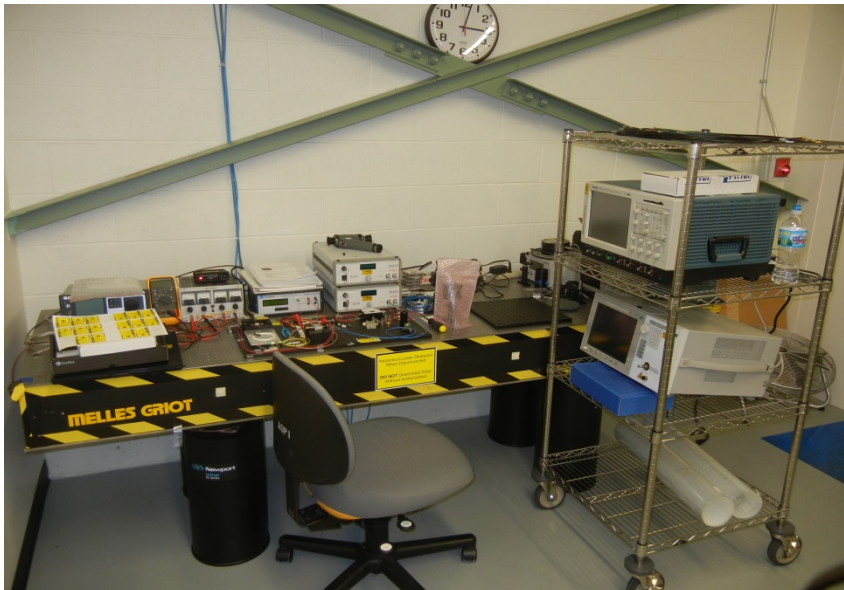

Conclusion



- Fermilab has installed and operated an initial laser profile monitor
- Future high-intensity H- accelerators will require both transverse and longitudinal laser diagnostics
- PXIE to provide a testbed for the development and testing various laser profile diagnostics