



U.S. DEPARTMENT OF
ENERGY Office of
Science

475.04.02 Production Solenoid

Vadim Kashikhin

L3 for Production Solenoid

7/8/2014

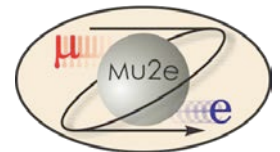

Requirements - role of Production Solenoid

The Mu2e magnet system consists of three large superconducting solenoids. Production Solenoid (PS) is the first magnet in the chain, which collects and focuses pions and muons generated in interactions of an 8-GeV proton beam with a tilted high-Z target and directs them towards Transport Solenoid (TS).

PS performs the following functions in the mu2e:

- Maximizes muon yield by efficiently focusing secondary pions and subsequent secondary muons towards the Transport Solenoid (TS) system, in the momentum range to be stopped in the stopping target;
- Provides a clear bore for beam line elements such as the primary production target and secondary particle Heat and Radiation Shield (HRS);
- Allows the primary proton beam to be steered into primary target; allows outgoing proton beam to exit without striking PS magnet shield.

Requirements - general

- **Magnetic:**
 - Nominal peak field on the axis **4.6 T**;
 - Maximum peak field on axis **5.0 T**;
 - Axial gradient **-1 T/m**;
 - Gradient uniformity **± 5 %**.
- **Electrical:**
 - Operating margins: **≥ 30 %** in I_c , **≥ 1.5 K** in T_c ;
 - Operating current **$9 \div 10$ kA**;
 - Peak quench temperature **≤ 130 K**;
 - Voltage across terminals **≤ 600 V**.
- **Structural:**
 - Withstand forces at all conditions while part of the system or stand-alone;
 - Cryostated magnet weight **≤ 60 tons**;
 - Compliance with applicable structural codes.
- **Cryogenic:**
 - Cooling agent: LHe at **4.7 K**;
 - Total heat flow to LHe **≤ 100 W**;
 - Cryostat ID **1.5 m**;
 - Conduction cooling.
- **Radiation:**
 - Absorbed dose **≤ 7 MGy** total;
 - Minimum RRR of Al stabilizer in the operating cycle **≥ 100** .

Requirements - radiation environment

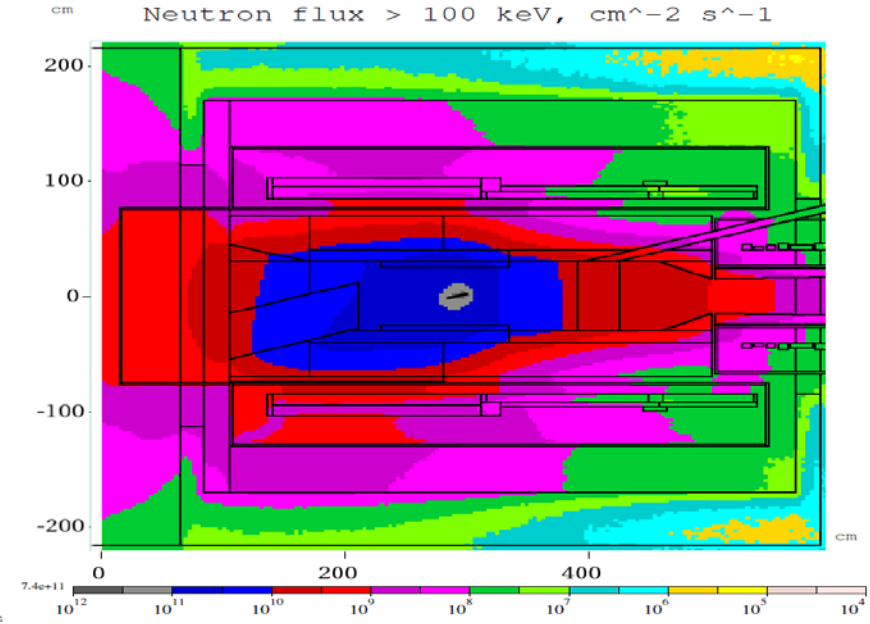
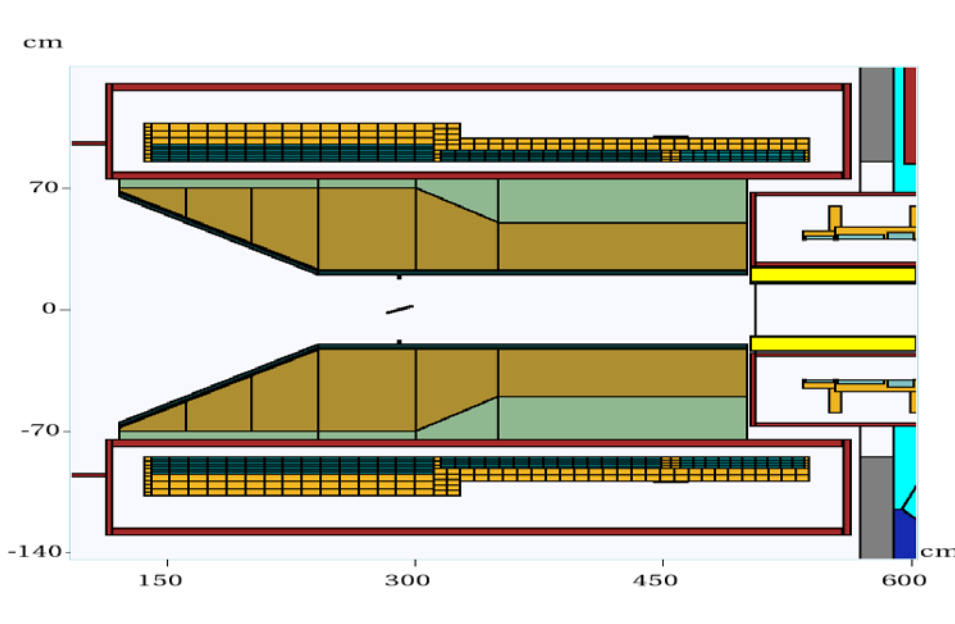

Parameter	Unit	Value
Peak absorbed dose	kGy/yr	240
Peak power density	μW/g	13
Total CM dynamic heat load	W	28
Peak DPA	1/yr	2.5 · 10 ⁻⁵

- It is expected that RRR will degrade after one year of operation as follows:
 - Al RRR 500 → 100;
 - Cu RRR 100 → 50;
- Once the critical degradation is detected, the magnet will be thermo-cycled to recover the resistivity.

Design - main features

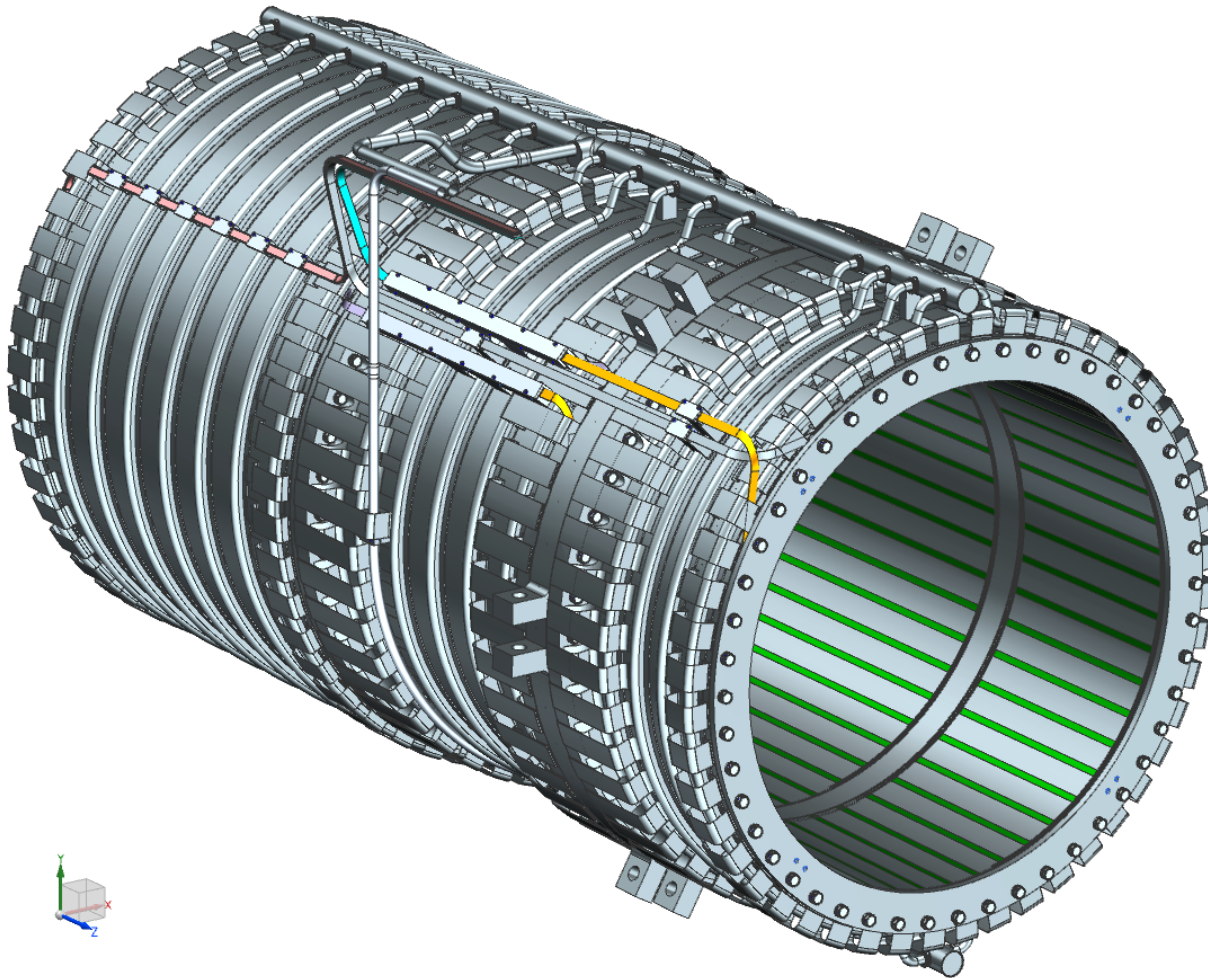

- PS consists of **three coil modules with 3-2-2 layers of the same Al-stabilized cable wound in the “hard way”**;
- Each module has an outer support structure made of **Al 5083-O** to manage the forces;
- The shells are **bolted together** to form a single cold mass assembly.
- The coil modules are installed inside of cryostat using axial and transverse supports.

Design – cold mass components

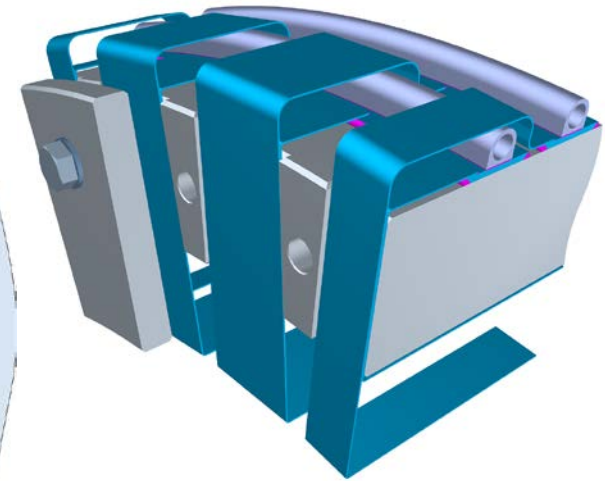
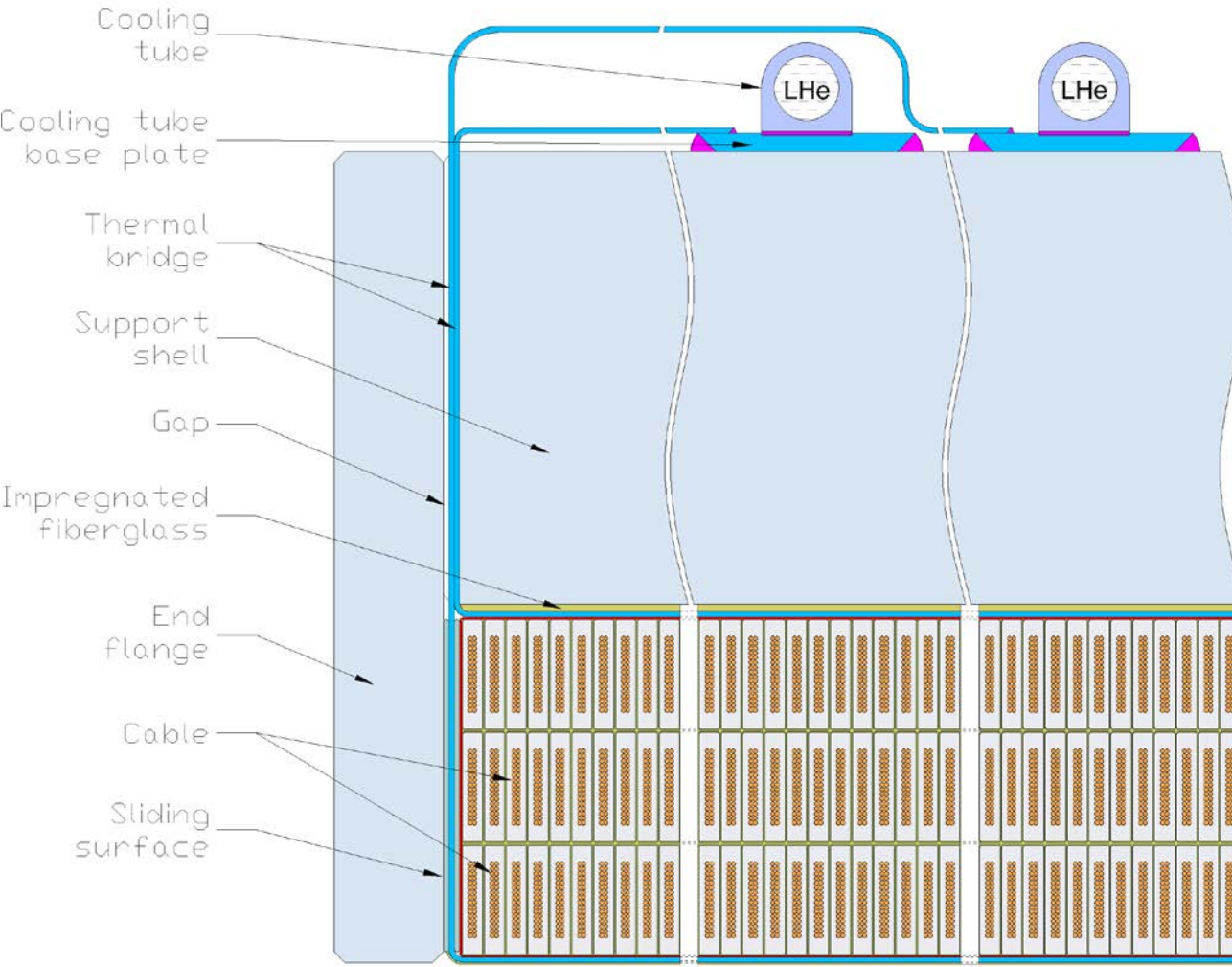

- Cables;
- Cable insulation;
- Ground insulation;
- Thermal bridges;
- Coil-shell buffer;
- Washer plates;
- Support shells;
- End flanges;
- Sliding layers;
- Cooling tubes.

Design - coils and insulation

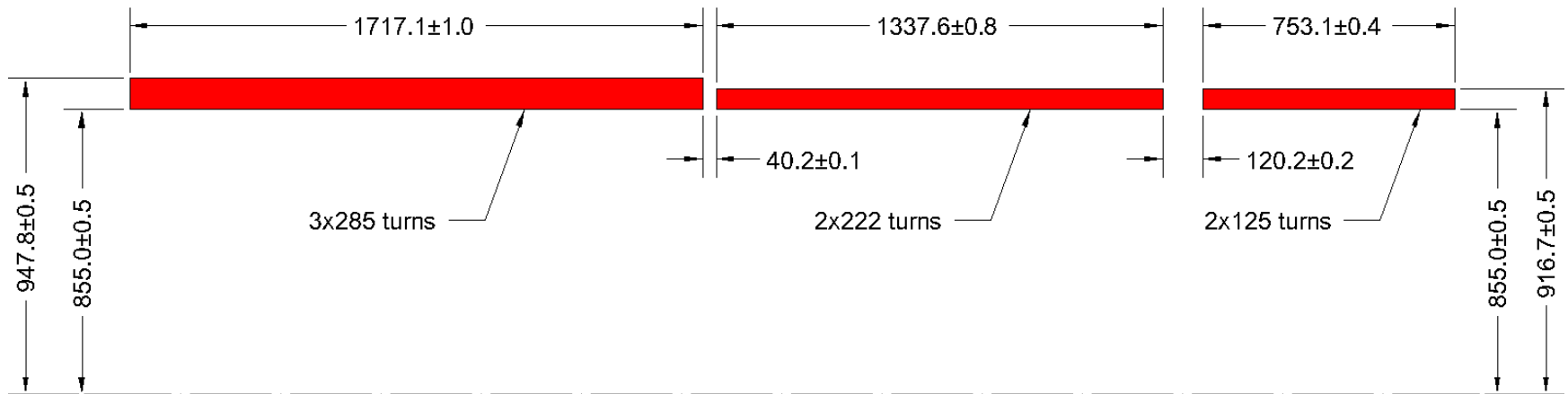

- The figure above shows the required coil envelope dimensions at RT.
- Cable insulation: composite “UG” tape similar to the one used in ATLAS CS;
- Interlayer insulation: dry E-glass, creates channel for epoxy penetration;
- Ground insulation: dry E-glass and polyamide or “GUG” ATLAS CS type insulation.

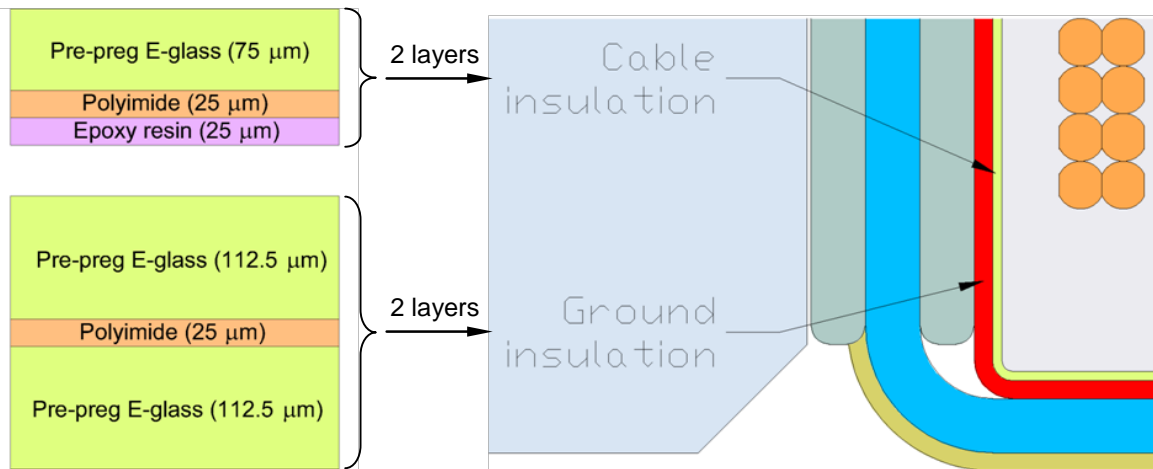

Design - thermosiphon System

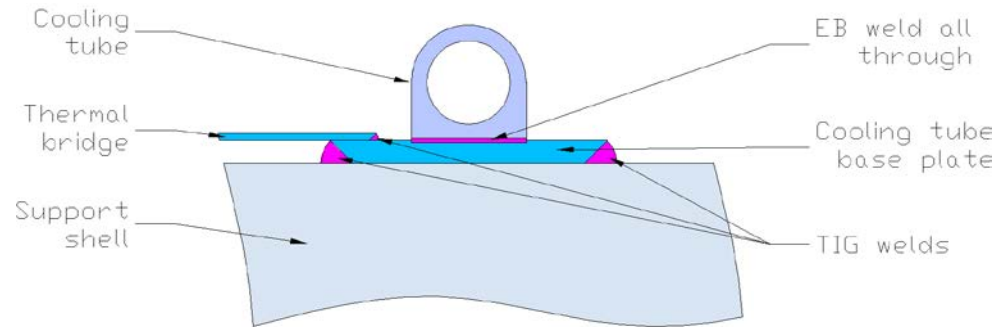
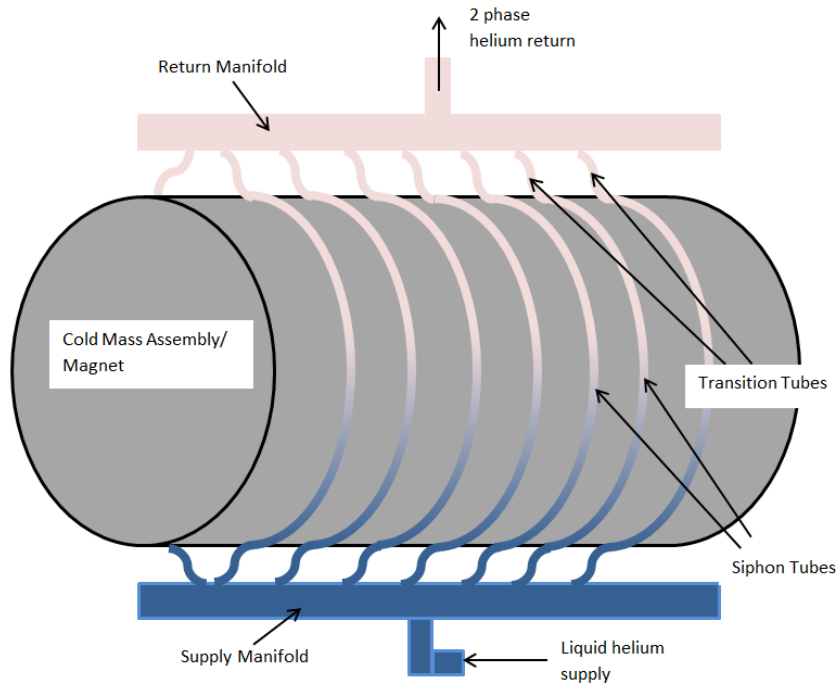

- Thermal bridges are the main elements of the coil heat extraction. The bridge connection to the cooling system is an important design detail;
- The D-shaped cooling tubes are **EB-welded to the base plates made of 5N Al**;
- The thermal bridges are **TIG welded to the base plates**;
- This design minimizes ΔT between thermal bridges and LHe.

Component	Outer Diameter (in)	Wall Thickness (in)	Material
Supply Line	1.25	.065	Aluminum 6061-T6
Supply Manifold	3.5	.25	Aluminum 6061-T6
Return Manifold	3.5	.25	Aluminum 6061-T6
Return Line	1.5	.065	Aluminum 6061-T6
Transition Tubes	1.25	.065	Aluminum 6061-T6
Siphon Tubes	1.5	.125	Aluminum 6061-T6

Design - cold mass suspension system

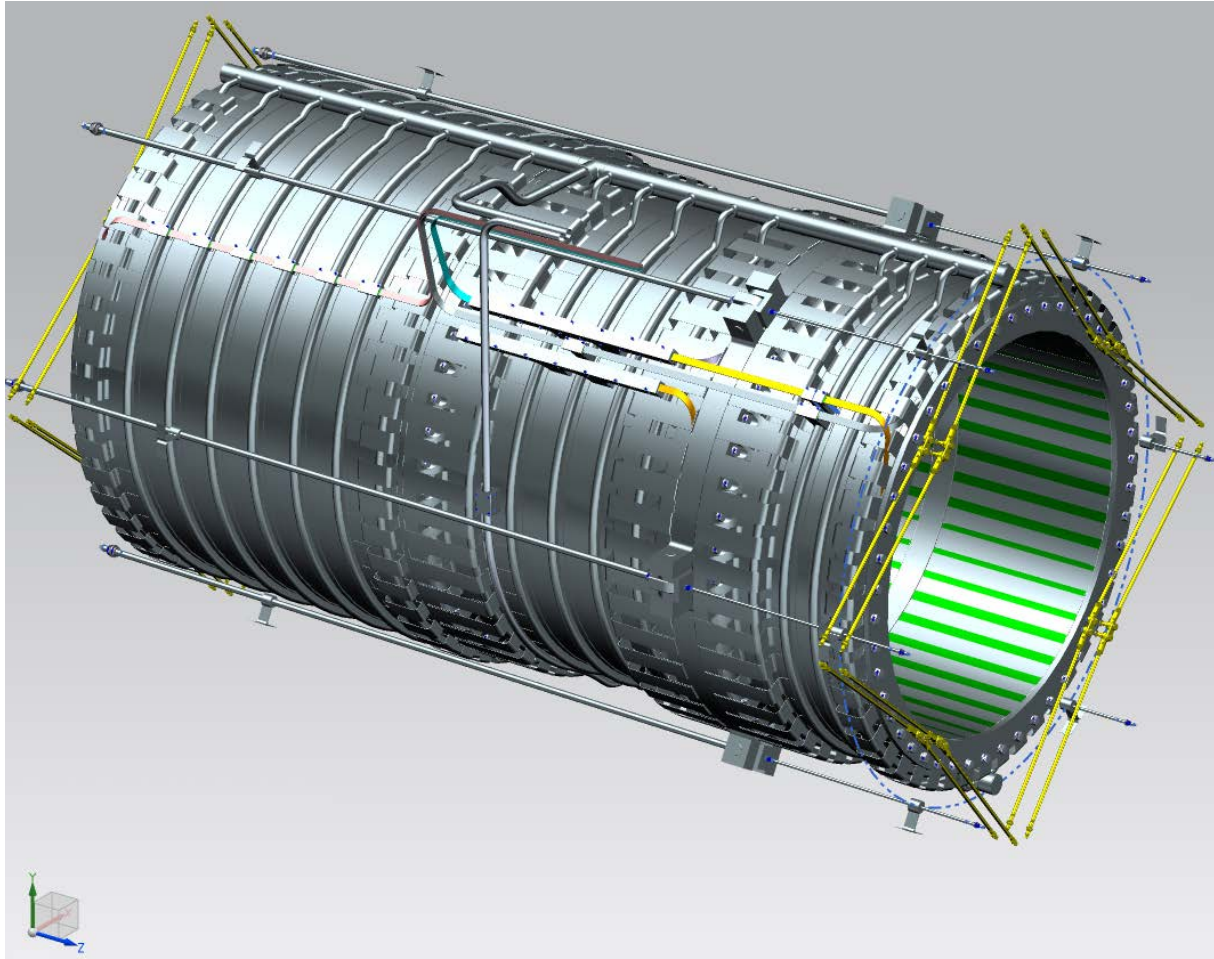

- Axial anchor system consists of **12 Inconel-718 rods** - 6 running from each end of the vacuum vessel and attaching to the spacer ring between the coils.
 - Each rod connects to the vacuum vessel through the Belleville springs to compensate the thermal contraction.
- Radial suspension system consists of **4 pairs of Inconel-718 rods** connecting each end flange to the outer shell of the vacuum vessel.
 - Half of the rods is loaded through the Belleville springs.

Changes since CD-1

- Initial RRR of Al stabilizer was reduced (600 → 500) to meet cable vendor capabilities;
- Plastic deformation of the Al stabilizer during cool-down and energizing has been extensively modeled. It was found that the shell thicknesses need to increase (83 mm → 125 mm, 50 mm → 70 mm) to comply with the structural code;
- High-strength Al alloy was selected instead of stainless steel for the bolts connecting the coil modules together;
- Trim power supply, extra bus-bar and HTS lead were eliminated. The field matching between PS and TS will be accomplished by trimming the current in TS1.

Value Engineering since CD-1

- The design has been largely “fixed” for the purpose of developing a detailed reference design report and solid models to solicit vendor quotes for the final design and construction.
- Trim power supply, extra bus-bar and HTS lead were eliminated.

Performance - magnetic field

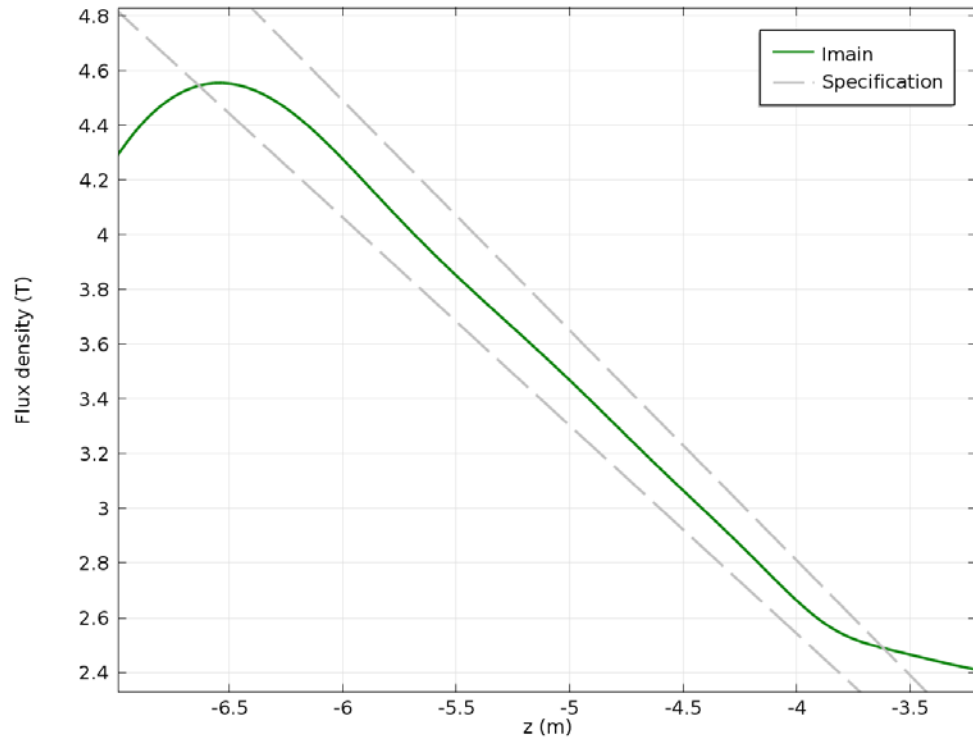
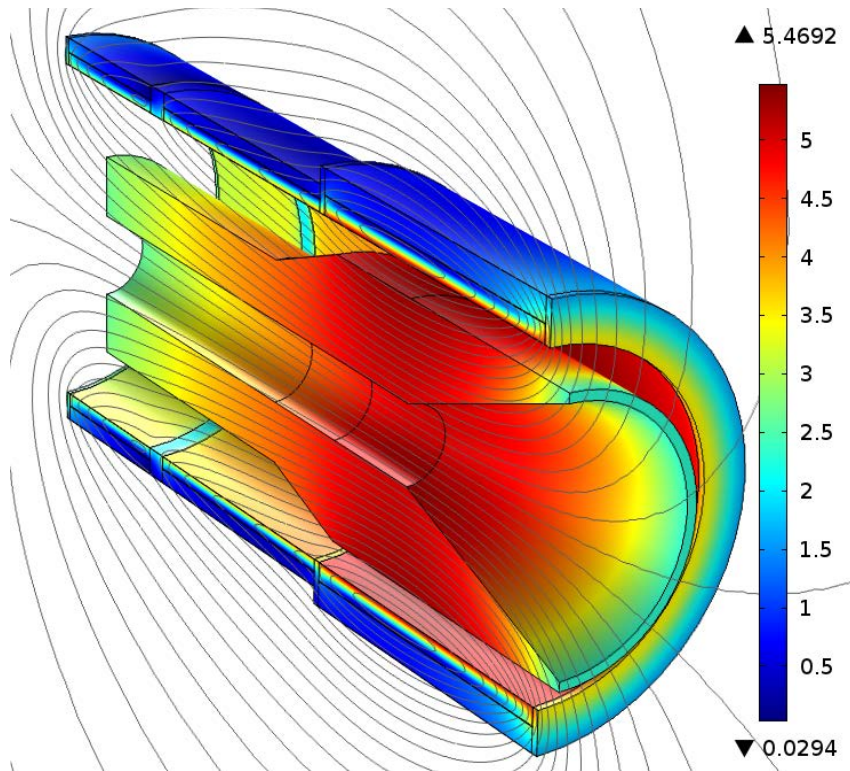

- The magnetic field profile is within the specification;
- Radiation shield (shown) made of high-resistivity bronze (magnetic permeability of 1.04) has minor impact on the field quality.

Performance – operating margins

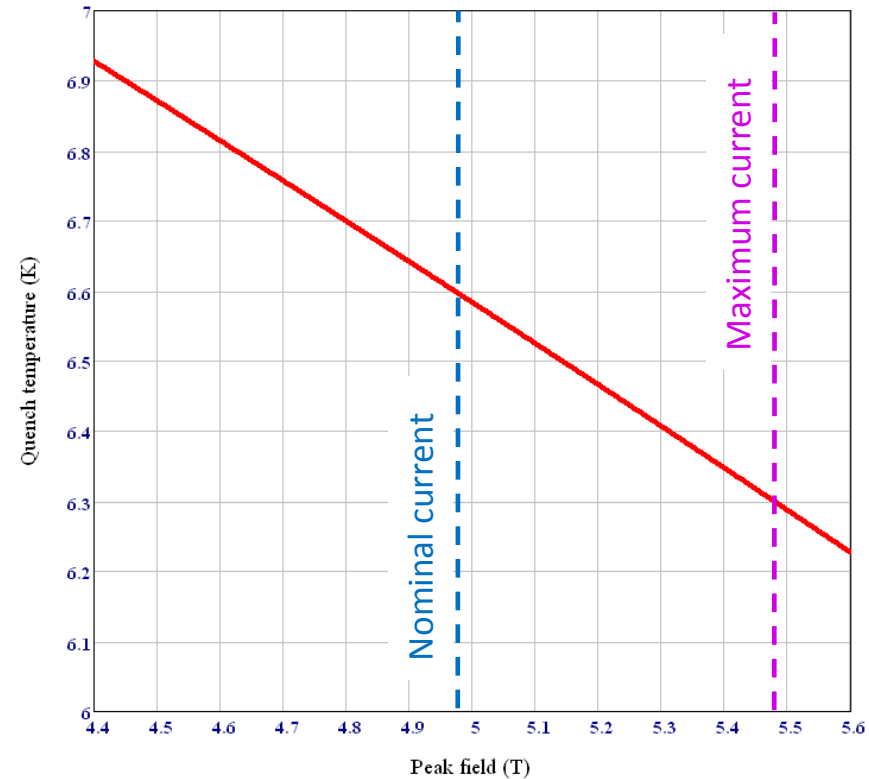
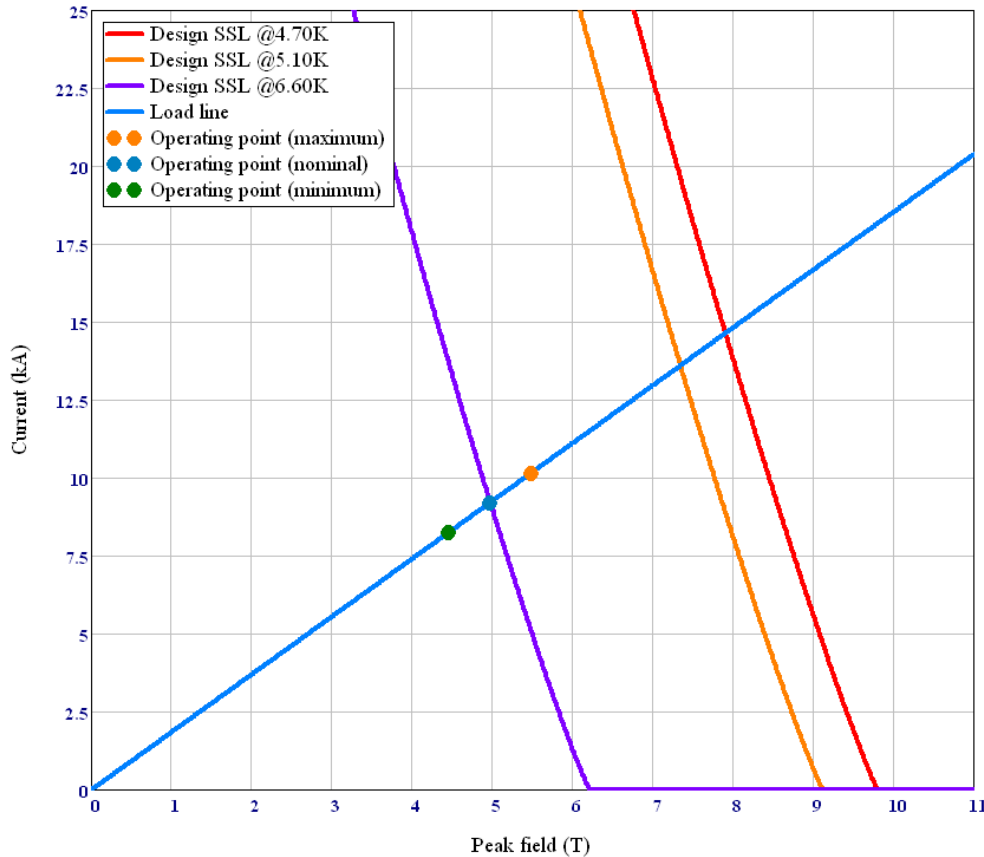

- The **1.5 K** thermal margin must be maintained during the nominal operation per the magnet requirements;
- It defines the maximum allowed coil temperature of **5.10 K** (at the nominal current).

Performance - quench protection

Time=0 Resistive zone (Ires/I)

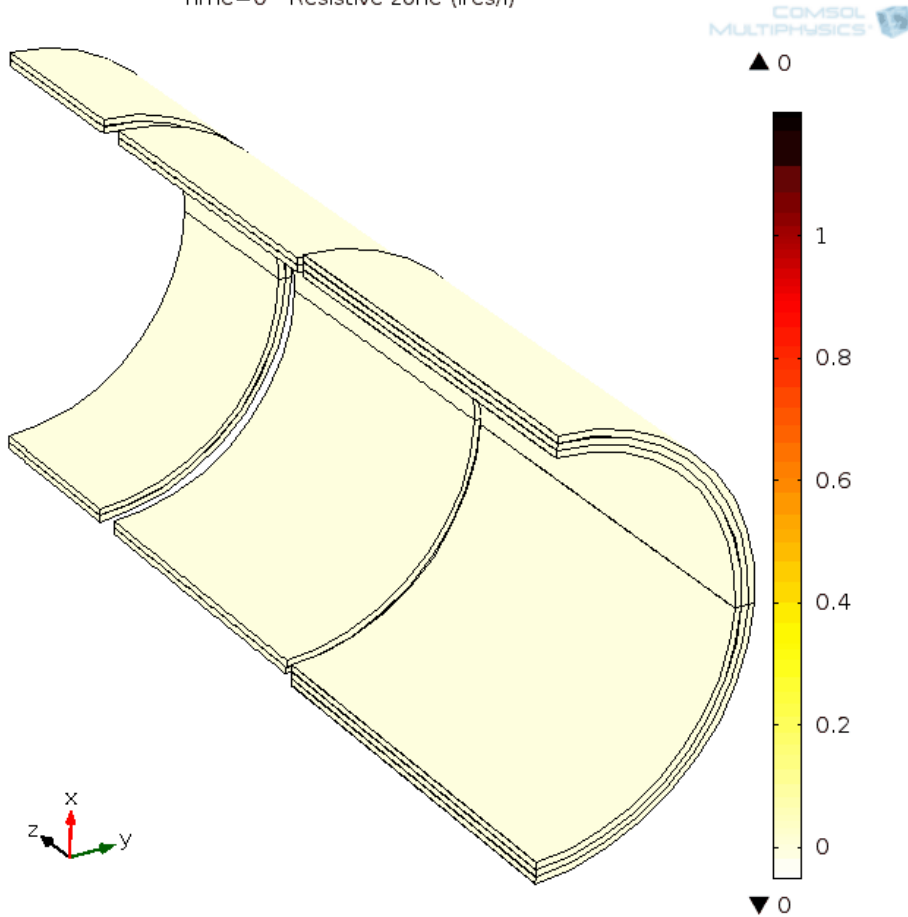

$RRR_{AI} = 100$, with the HRS

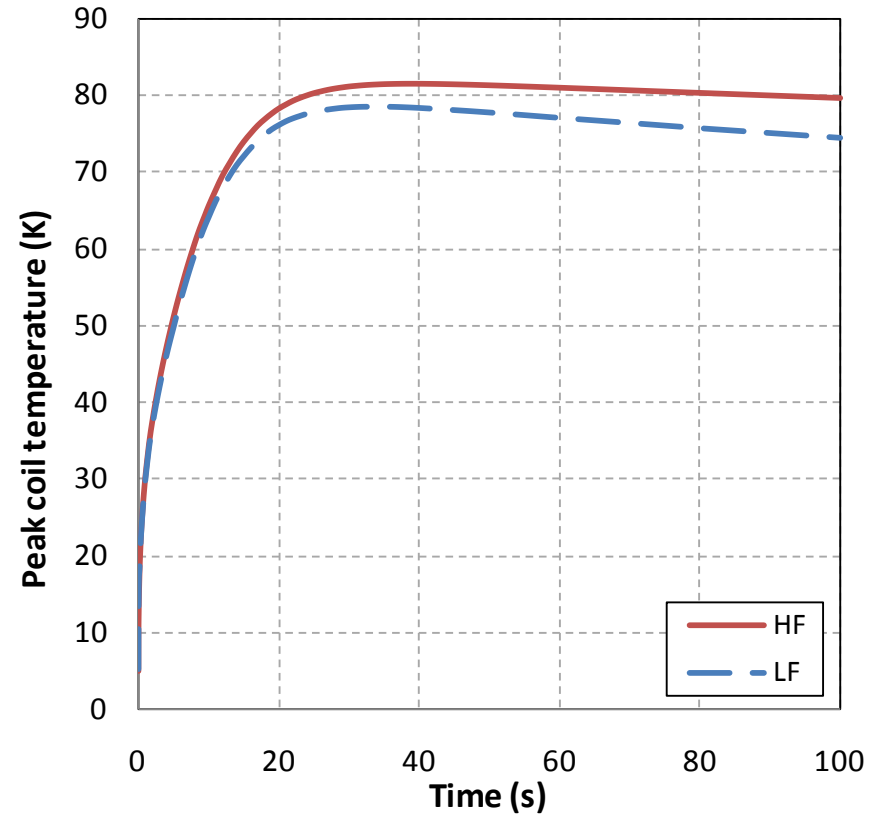

- The peak coil temperature is well below the limit of **130 K** during normally-protected quenches.

Performance - structural analysis

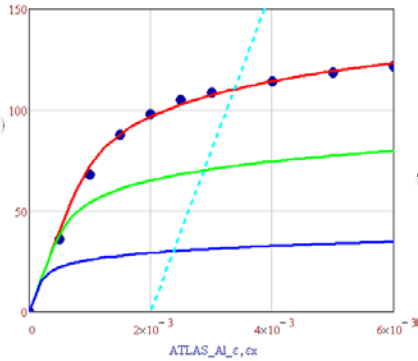

$T = 5 \text{ K}, I = I_{\max}$

elastoplastic
coil properties

von Mises stress (MPa)

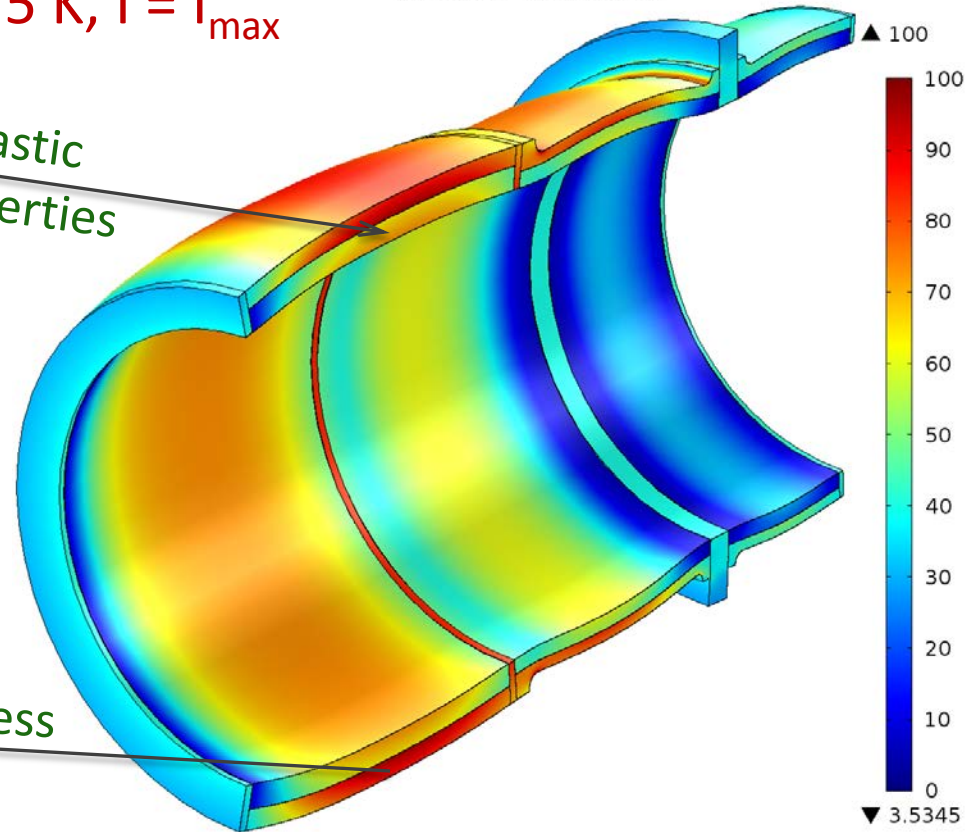

peak stress

96 MPa

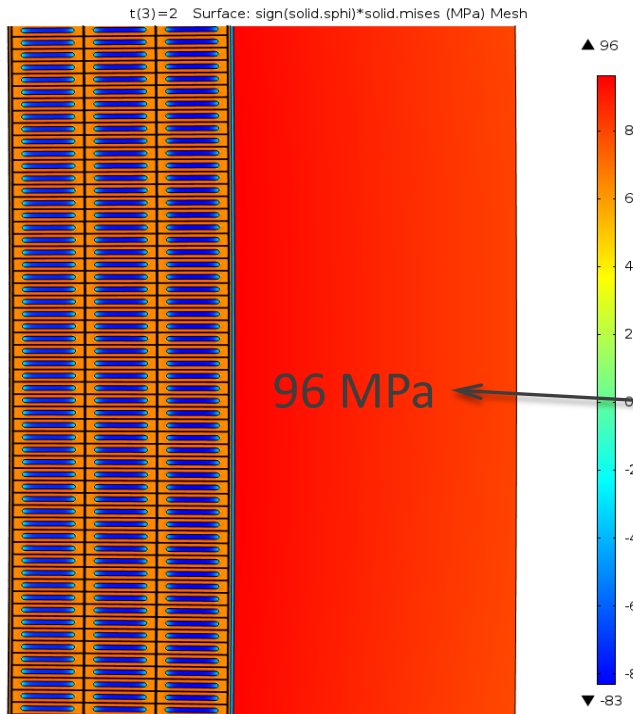

- The peak shell stress is within the maximum allowable value specified by ASME BPVC.

Performance – thermal analysis ($T_0=4.7$ K)

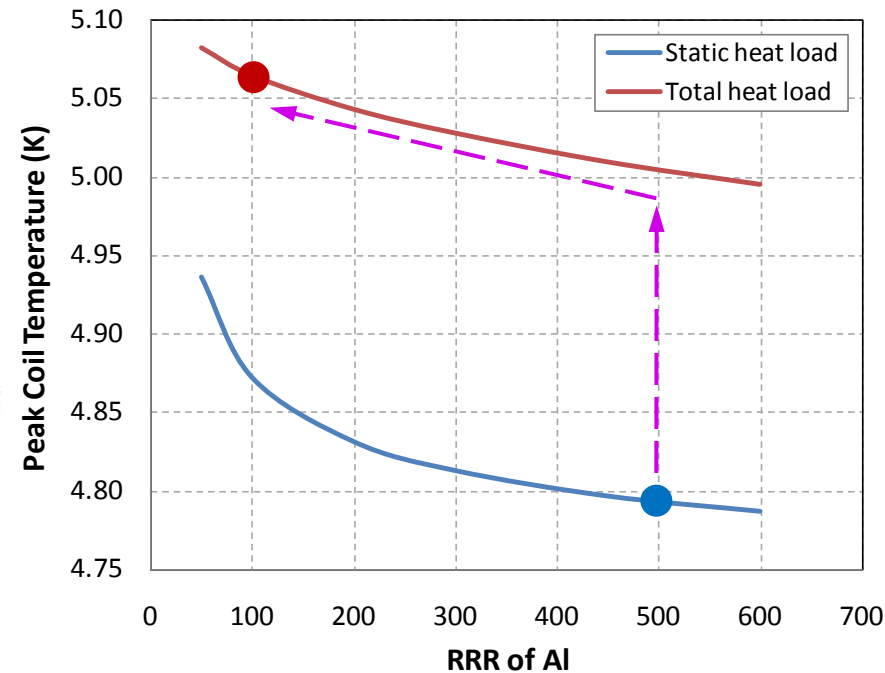
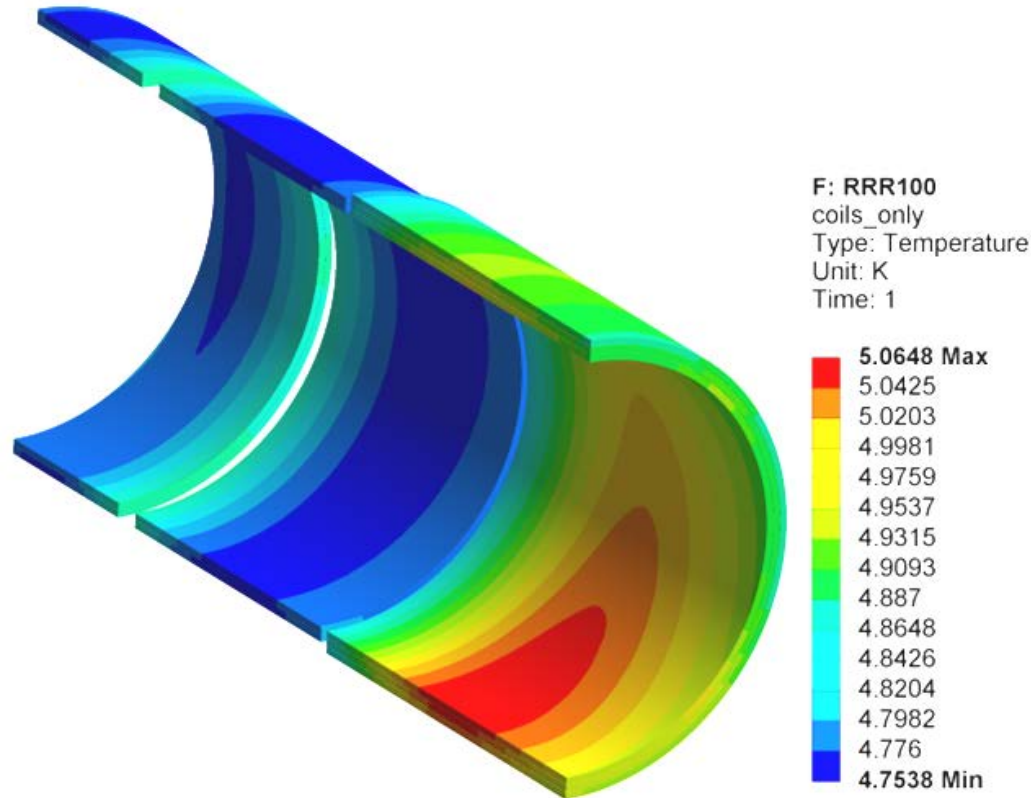

- Operation conditions:
 - RRR = 500, static heat load;
 - RRR = 500 → 100, static+dynamic heat load;
- The peak temperature is below the maximum allowable value at all conditions.

Remaining work before CD-3

- Procure long-lead items:
 - Order the production quantity of PS cable
 - Hold points – delivery of the first 100 m of cable (prototype) and the longest piece length of 1.7 km (first article);
 - Order final engineering design of PS by the magnet vendor;
- Conduct technical review of the final PS design;
- Prepare final design and drawing of the PS support stand;

Quality Assurance

- The reference design fulfills all the requirements, complies with the structural codes and has appropriate margins used in the design of similar magnets;
- The magnet vendor has flexibility in changing the reference design to optimize the fabrication process. In such case, the vendor is responsible for demonstrating that the modified design still meets the requirements;
- Technical review of the final PS design is conducted before the magnet vendor is granted permission to fabricate the magnet;
- An extensive acceptance testing will be performed on the production cable prior shipping it to the magnet vendor;
- The magnet vendor has to implement a quality assurance plan that meets the requirements for the design and construction of PS and develop a traveler system;
- The magnet vendor is to built a model coil to validate the magnet production tooling;
- A number of hold points prior to the critical operations will be included in the fabrication schedule. The vendor's progress will be continuously monitored and corrected as needed;
- An extensive acceptance testing will be performed on the magnet at the vendor site and after delivery to FNAL.

- **Radiation:**
 - The PS and its surroundings will become radioactive and access will be restricted in accordance with Fermilab procedures.
- **Cryogenic:**
 - Potential for oxygen deficient atmospheres (ODH). An (ODH) analyses will be conducted. Emergency response procedures will be developed for responding to alarm systems.
- **Stored Magnetic Energy:**
 - 80 MJ of stored energy in PS the powering circuit. Quench protection systems have been designed to dissipate the stored energy in the solenoids in a controlled and safe fashion.
- **Coupled Magnetic forces:**
 - There are large forces within the PS itself as well as between the PS and TS. The PS is designed to resist these forces, but access to the magnet will be restricted during the times when it is powered.
- **Stray Magnetic Fields:**
 - >5 gauss fields are of particular concern because they can affect medical electronic devices (pacemakers); fields >600 gauss can impact ferromagnetic materials. The fringe field analysis document is in Docdb - Mu2e Document 1381.
 - The PS has no return yoke. Access will be restricted when it is powered and warnings will be posted for persons with pacemakers.

Cost Distribution by Resource Type

Base Cost (AY k\$)

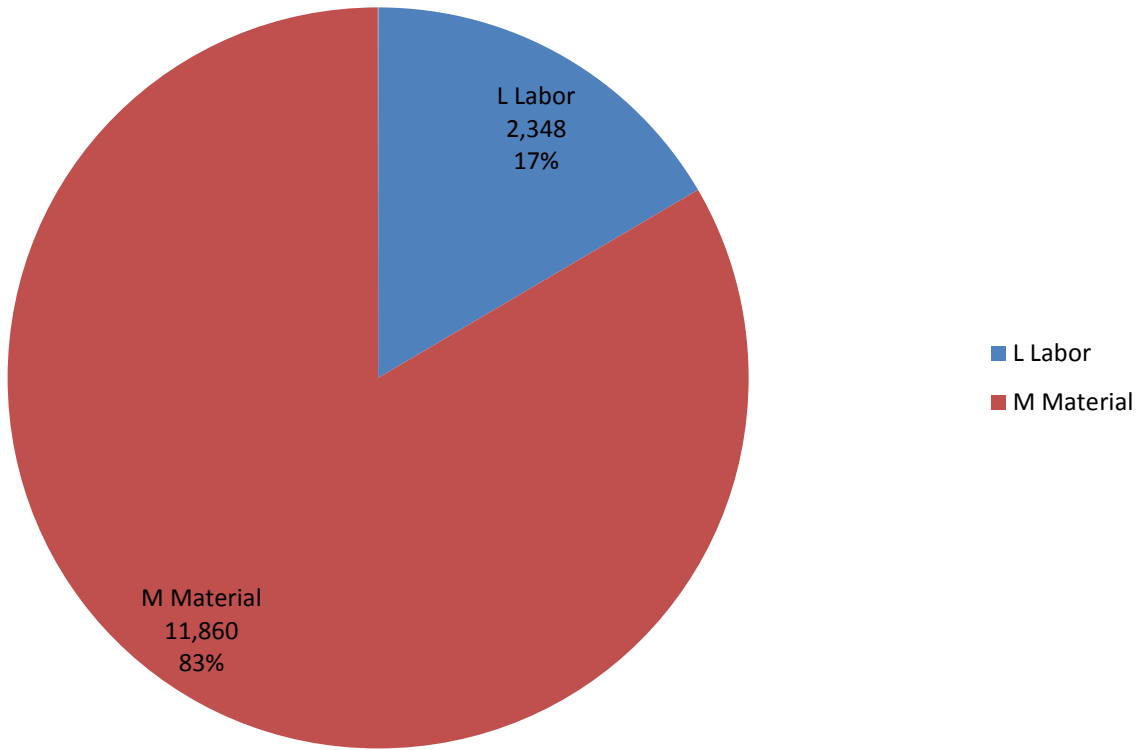

Quality of Estimate

Base Cost by Estimate Type (AY k\$)

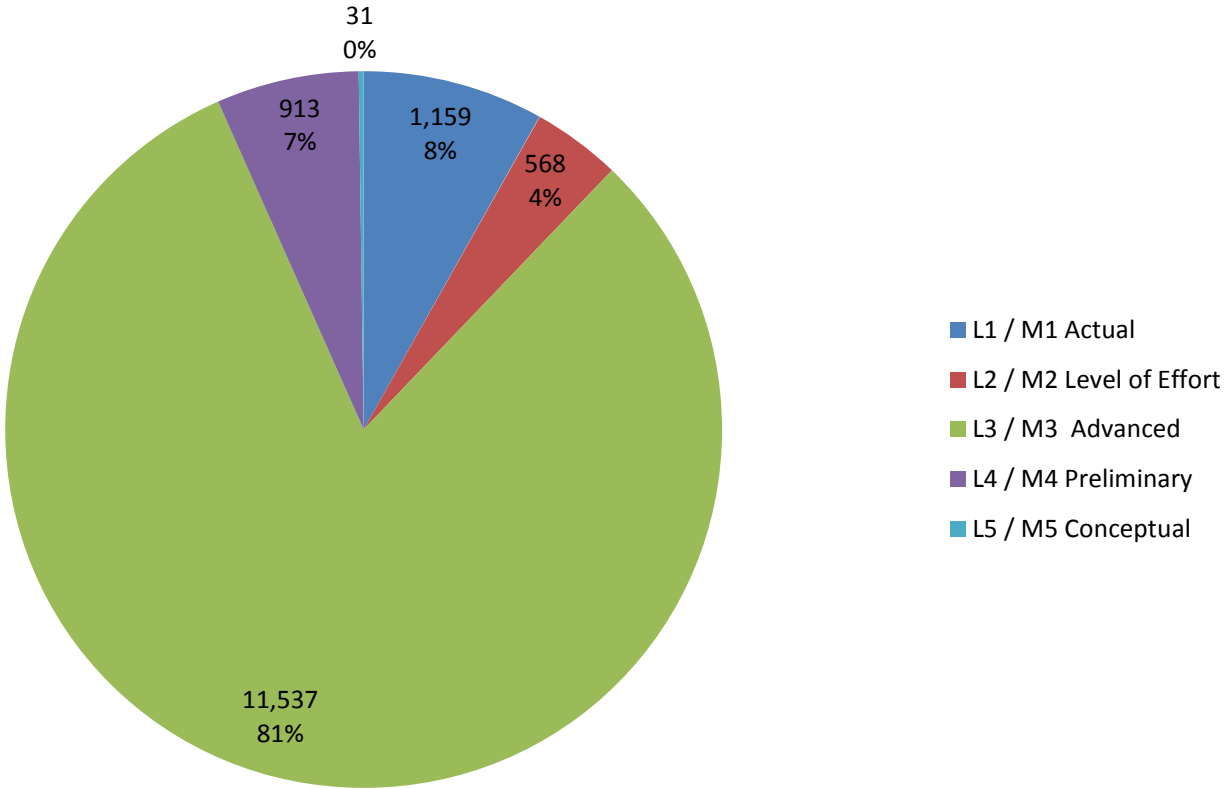

Labor Resources

FTEs by Discipline

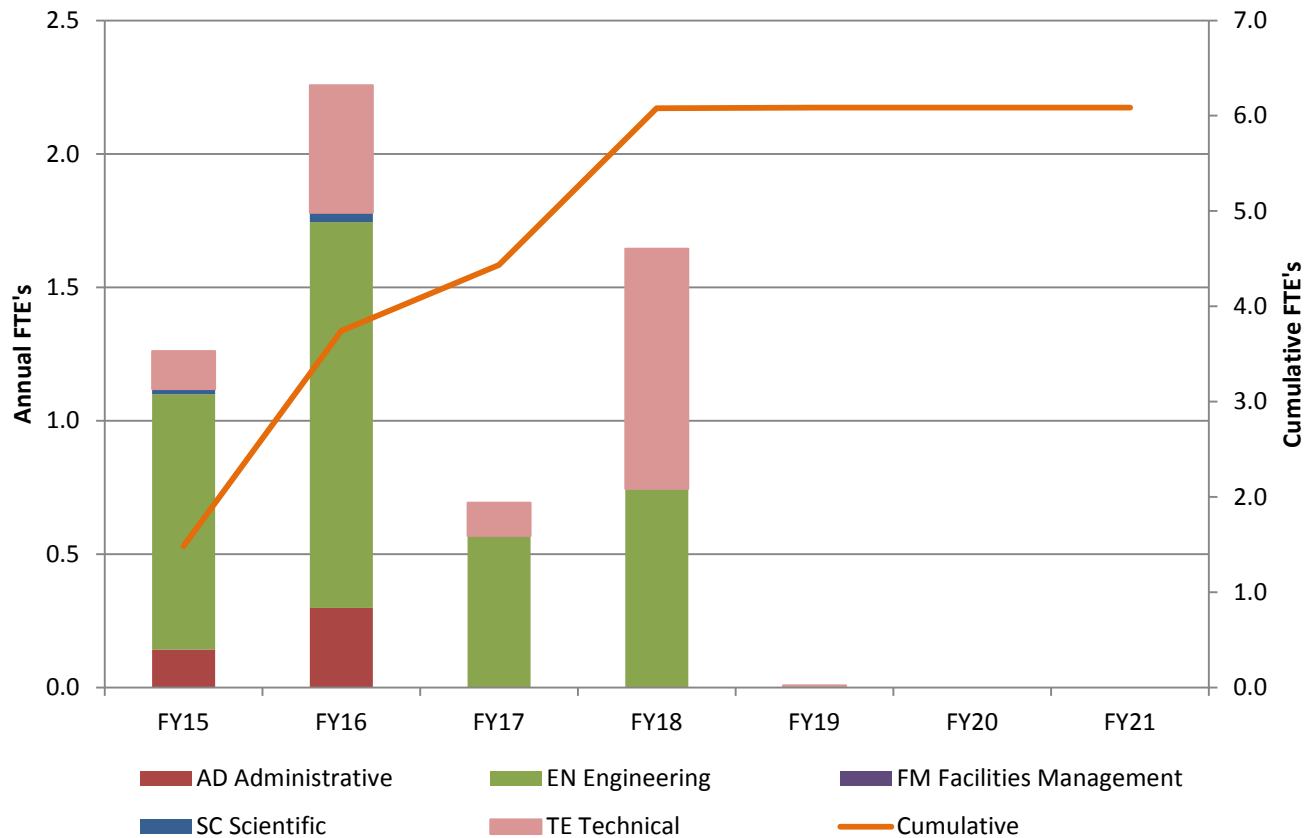

Cost Table

WBS 4.2 Production Solenoid

Costs are fully burdened in AY k\$

	M&S	Labor	BAC	Estimate Uncertainty	% contingency on ETC	Total
475.04.02 Production Solenoid	11,860	2,348	14,208	2,302	18%	16,510

Schedule

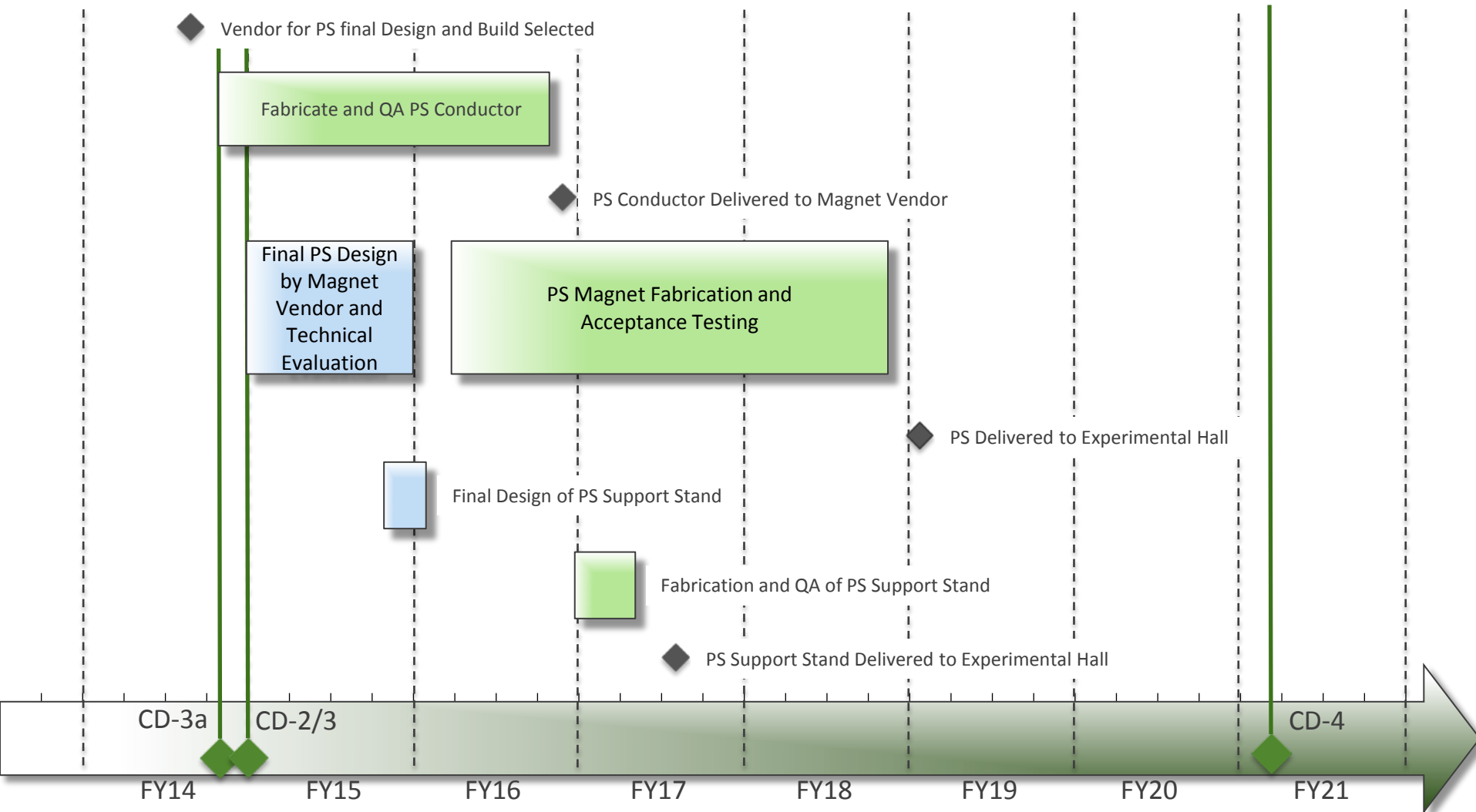

Summary

- The PS reference design meets all the requirements; the magnet vendor is to develop the final engineering design; technical design review will be performed prior to the magnet construction;
- The magnet vendor has been selected. The vendor proposal for the final design and construction is included into the project cost and schedule;
- ES&H issues have been analyzed and addressed;
- Order for the production quantity of the PS cable is ready to be placed;
- PS is ready to move into the final design phase.