



U.S. DEPARTMENT OF  
**ENERGY** Office of  
Science

---

## 475.04.08 Field Mapping System

Michael Tartaglia  
L3 Manager for Field Mapping System  
7/8/2014

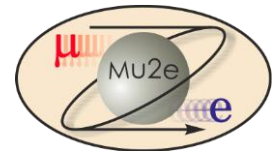

# Requirements

---

- Mu2e Docdb #1275:
  - Map  $\{B_x, B_y, B_z\}$  along DS bore ( $0 < R < 70\text{cm}$ )
    - DS-only during commissioning – QA check of DS magnetic field
    - Final magnetic configuration; DS at reduced currents (calibration settings)
    - Most demanding – precise tracker region requires  $\Delta B/B \sim 10^{-4}$
  - Map  $\{B_z, B_r\}$  and  $\{dB_z/dz\}$  in PS along HRS bore (limited to  $R < 17\text{cm}$ )
    - PS-only during commissioning – QA check of PS magnetic field, HRS permeability
    - Final magnetic configuration (all solenoids powered)
  - Map  $\{B_z\}$  into PS/TS1 and DS/TS5 collimators (limited to  $R < 15\text{cm}$ )
    - Final magnetic configuration; TS adjustments and trim power supply settings
  - Monitor  $\{B\}$  in DS spectrometer region during Mu2e operation
  - Monitor  $\{B_z\}$  and  $\{dB_z/dz\}$  along TS1, TS3u, TS3d, TS5 collimators ( $R \sim 15\text{cm}$ )
    - Measure straight section continuous negative gradients, final magnetic configuration
  - Perform Electron Source Test (off project)
    - Map electron transport through TS, final magnetic configuration

# Design

- DS Field Mapper
  - Probe positioning mechanism, similar to CMS solenoid mapper
  - Axial motion along precise DS detector support rails
  - Modern calibrated 3D Hall probes at fixed  $\{R_i\}$  on rotating “propellers”
    - Shaft extension to map into TS5 collimator

$\theta$  drive: 270° continuous air motor, geared 360° motion  
Angle encoder

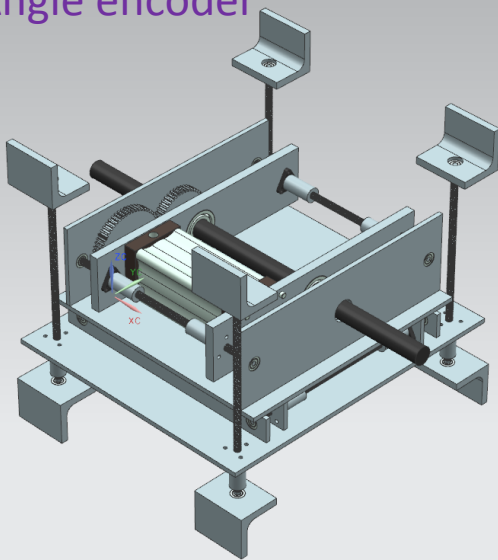

Fixed position NMR probes

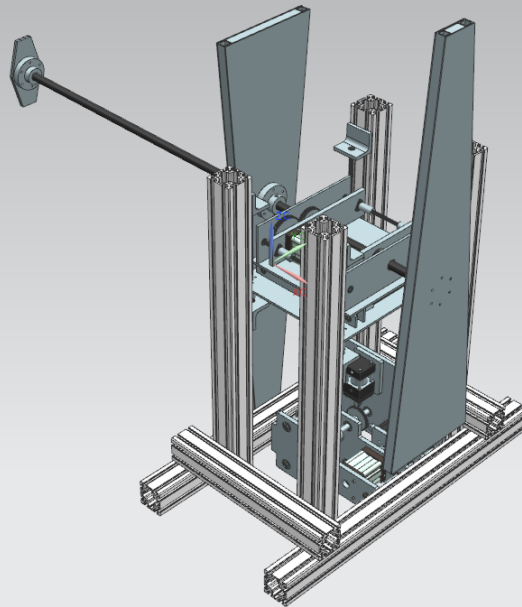

Z drive: stepper air motor, piezo control valves, toothed drive belt, position encoder

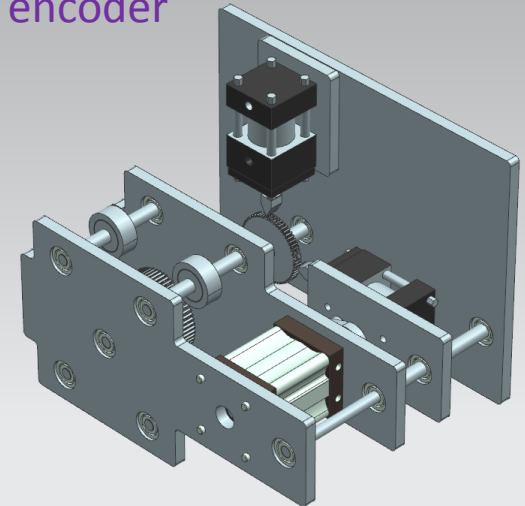

# Design

---

- DS Field Mapper
  - 3D model, bill of materials ~complete
  - Developing preliminary drawings
- Field Mapper DAQ and Controls
  - New FNAL/TD Magnet Measurement System
    - Configurable, Extensible, Modern Software Architecture
    - Software framework & component developments are advanced
    - Utilize mostly commercial off-the-shelf components
      - PXIe, NI, Labview; Metrolab NMR
    - Hall and NMR prototype (calibration) system testing started
  - Detailed instrumentation design will begin soon
    - Readiness for CD-3

# Design

---

- PS Field Mapper
  - Hall probes to measure field strength and gradient
    - Will be calibrated in Tevatron Dipole to 5 T
  - Probe positioning mechanism still very preliminary
    - Following evolution of PS bore (HRS=heat & radiation shield)
    - Utilize linear guide supported by HRS bore and upstream flange
    - Cantilevered section downstream of target support ring
    - External Z-drive system & encoder
    - Azimuthal positioning with non-magnetic rotary piezo stage
  - Detailed mechanical design will begin soon (after DS)
  - Same Control & Instrumentation as DS
    - Tailored interface boxes and separate cabling

# Design

- PS Field Mapper
  - PS with Heat & Radiation Shield

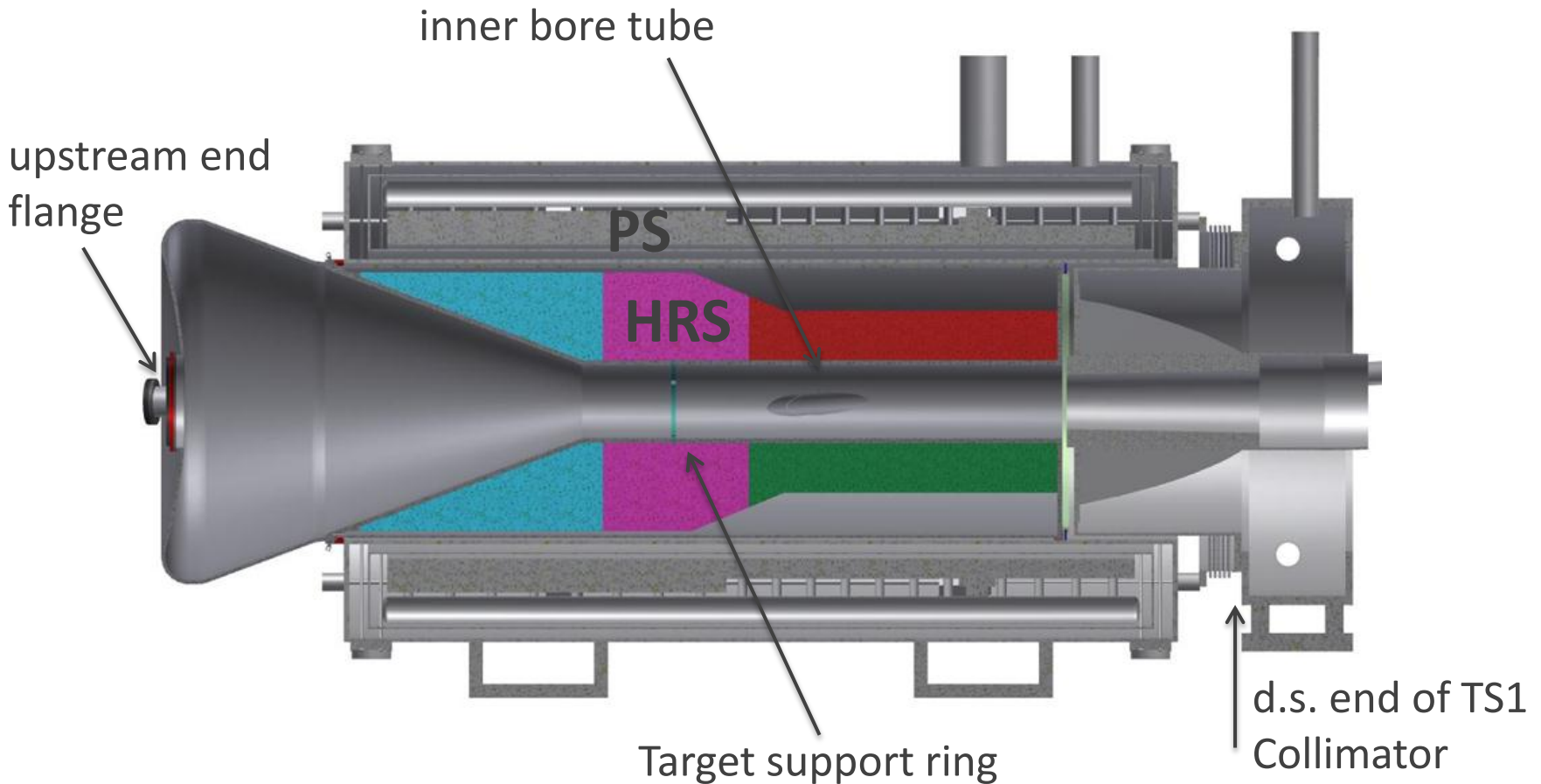

# Design

---

- In-Situ Sensors
  - NMR probes in DS spectrometer region
    - Mounted to inner bore (fixed positions to detect field changes)
      - In place during field mapping
    - Mounted to tracker frame ends (distinguish position changes)
      - Re-use probes from DS field mapper
    - Same electronics used during DS field mapping
  - Hall probes in TS Collimators
    - This is the only viable approach to check TS3 straight regions
    - Expect to map TS1 & TS5; these sensors monitor changes over time
    - 1D Hall probes (& RTDs) embedded in collimators (3 designs)
      - after epoxy-impregnated construction in precisely spaced pre-machined slots
    - Read out by multiplexed instrumentation system (all magnet sensors)
      - Working on wiring and signal feed-through design details

# Design

- TS Collimator In-Situ Sensors

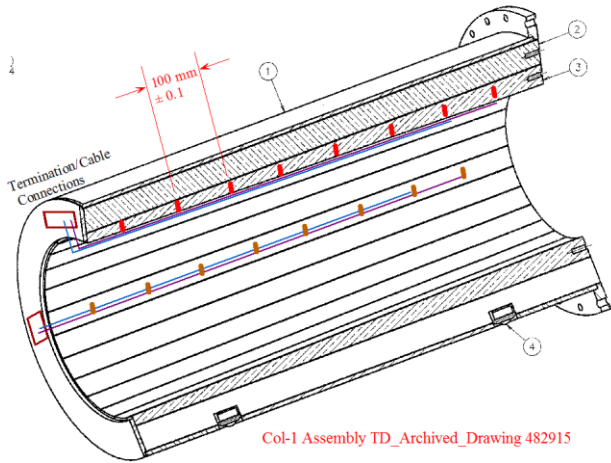

TS1 Collimator

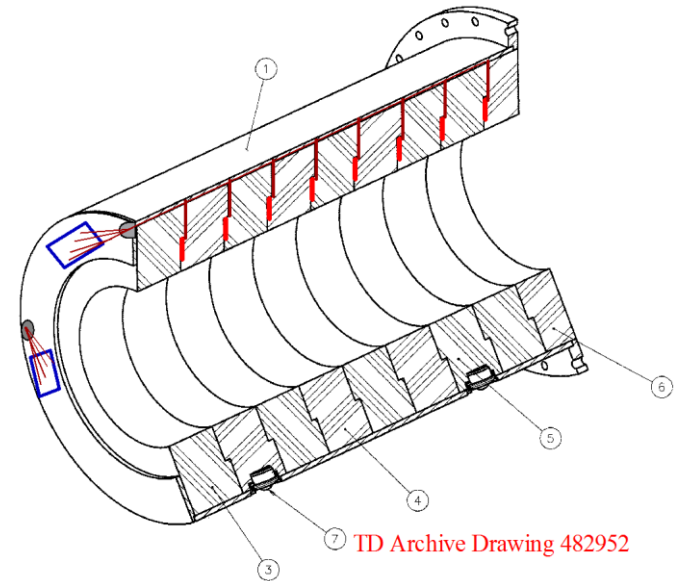

TS5 Collimator

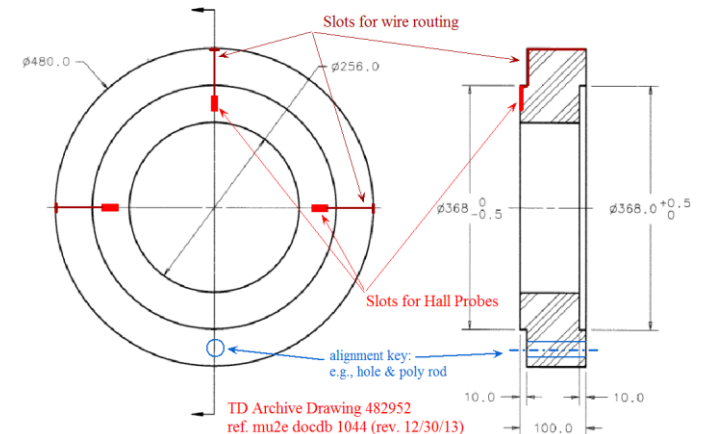
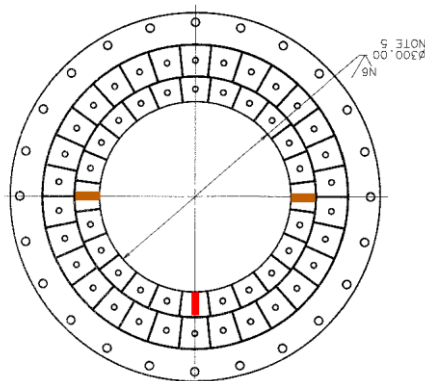



# Design

---

- Electron Transport Test
  - Off project; design & cost studied under Field Mapping WBS
  - Validate transport from primary target region through TS1,3,5 collimators to stopping target in “final magnetic configuration”
    - Position source near primary target position
      - Few-MeV Beta or Electron Conversion Source
      - Re-use PS field mapping device to move the source
      - Need components to allow rough evacuation of Muon Beamline
    - Detect electrons at downstream positions
      - Thin Scintillator tiles with on-board SiPM detectors (& electronics?)
      - Study detected position versus start position
        - Simulation in progress to define detector segmentation
      - Step 1: Detect at TS3 pbar-window gap (test TSu transmission)
      - Step 2: remove TS3 detector, detect at DS stopping target

# Changes since CD-1

---

- Production Solenoid/TS1 Collimator
  - No longer mapping the PS full aperture
    - Heat & Radiation Shield will now be an integral part of PS
    - Field mapping only in limited aperture of the HRS bore
    - Target support ring ~17 cm radius
  - Bkgd Simulations → new pbar window requirement
    - upstream of TS1 Col → could impact TS1 mapping
    - Looking at timing and method of this material installation
    - Electron Source Test could also be affected

# Value Engineering since CD-1

---

- Control and DAQ Readout Same Controls and DAQ Readout System will be utilized for both DS and PS (map one at a time; tailored interface boxes and software configurations)
- PS field map Hall Probe positioning device will also be used to position the Electron Source in the E.S.Test
- In-Situ Hall probe readout system will be common with all other magnet sensors
- Same NMR probes and instrumentation will be used both for mapping and in-situ monitoring of DS field

# Downselects

---

- Electron Source Test at CD-1 considered using low energy electron gun array, vs radioactive source on positioning stage
  - Few MeV Beta or Conversion source has several advantages

# Remaining work before CD-3

---

- Complete preliminary designs
- Complete preliminary design drawings
- Complete final designs
- Complete final design drawings

# Quality Assurance

---

- All mechanical components & materials will be inspected, and tested for magnetic properties (proximity to NMR in calibration magnet) for conformance with specifications
- All Hall probes & electronics will be calibrated to the required level over the specified operating range; probe tilt angles and sensitivity to temperature variations will be measured
- Multiple probes provide redundancy for cross-checks; NMR probes provide absolute field at reference points
- Metrology will be used to determine the precise probe positions: for internal alignment, adjustment, and motion
- Entire system will be assembled, bench- and field- tested well in advance of solenoid cryogenic and powered operations
- Data analysis tools will be developed and ready to allow rapid evaluation of data quality during the field mapping operations

# Risks

---

- No major risks have been identified with field mapping

- ES&H issues associated with Field Mapping System and Operation:
  - DS confined space: access to DS bore is required for installation and removal of Field Mapper Z-drive belt
  - During cryogenic operations: ODH conditions may apply within regions of the Mu2e Hall
  - During magnet powered operations: high magnetic field hazard will apply within some regions of the Mu2e Hall
  - Electron Source Test: training in proper handling and storage of radioactive source (beta or electron conversion) will be needed



# Cost Table

- Provided by Project Office

	Base Cost (AY k\$)			Estimate Uncertainty (on remaining costs)	% Contingency on ETC	Total Cost
	M&S	Labor	Total			
475.04 Solenoids						
475.04.08 Magnetic Field Mapping System						
475.04.08 Magnetic Field Mapping System	430	726	1,156	501	44%	1,657
Grand Total	430	726	1,156	501	44%	1,657

# Quality of Estimate

- Provided by project office

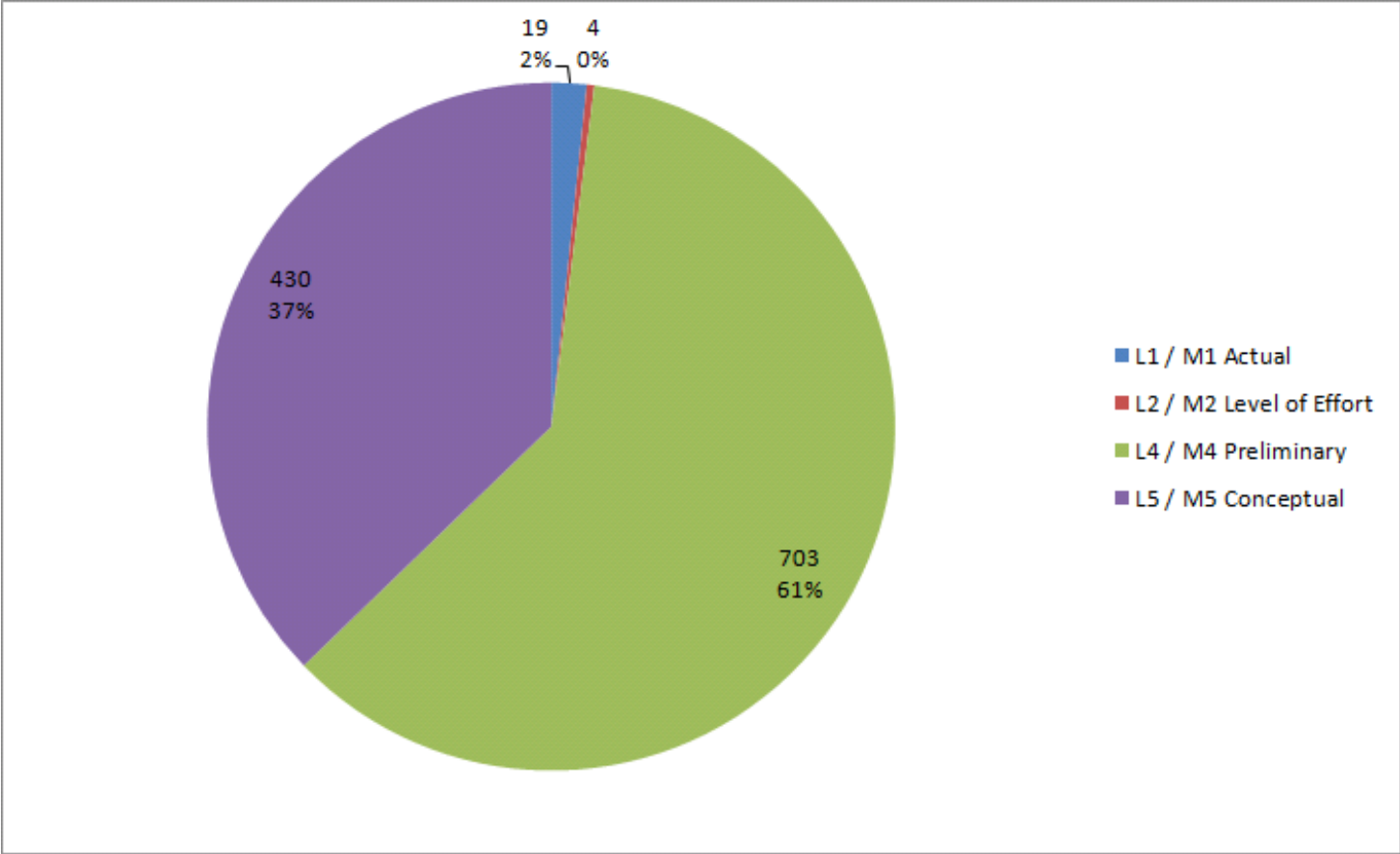

# Resource Type

- Field Mapping System Resource Type

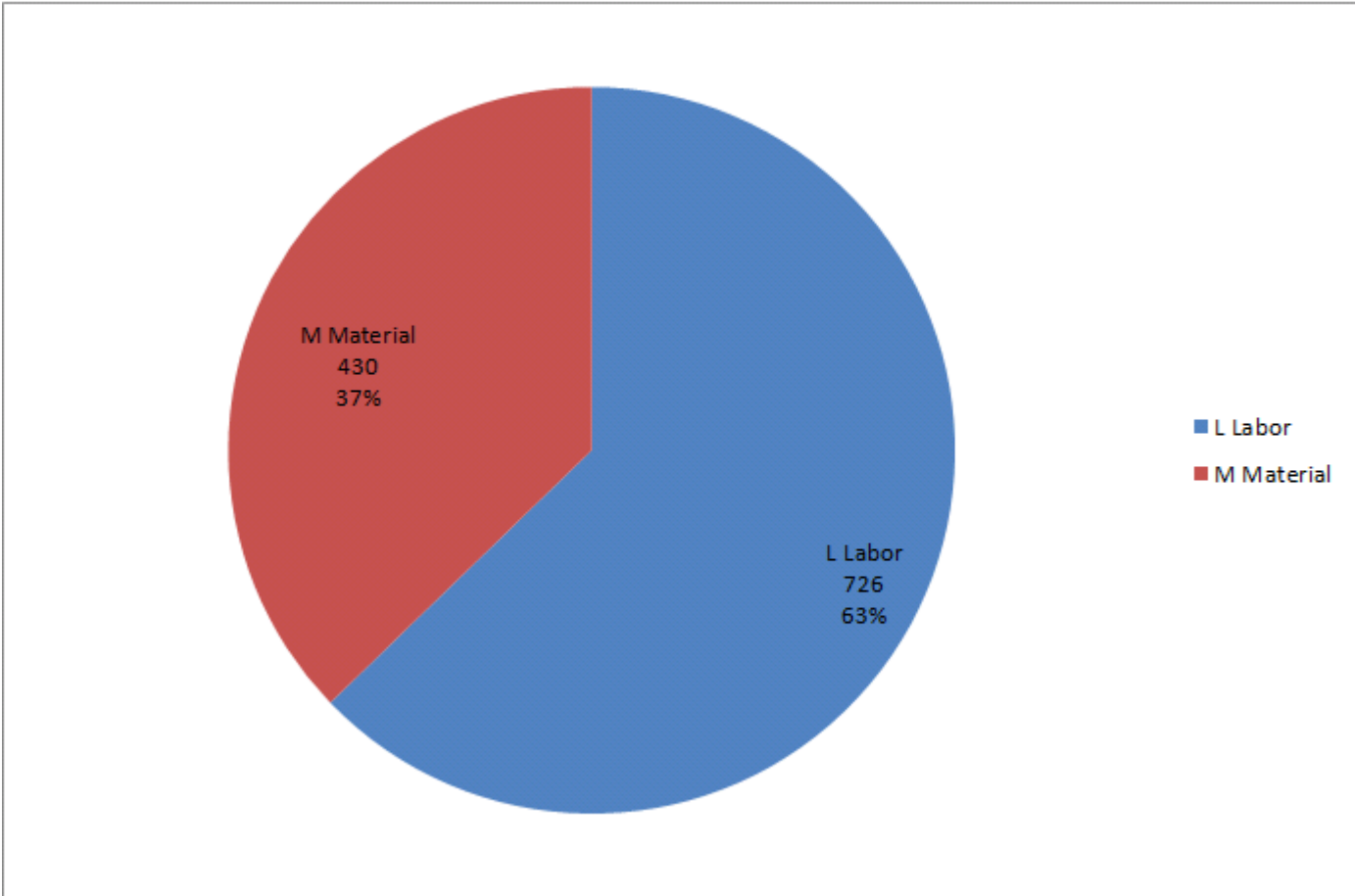

# Labor Resources by FY

- Provided by Project Office

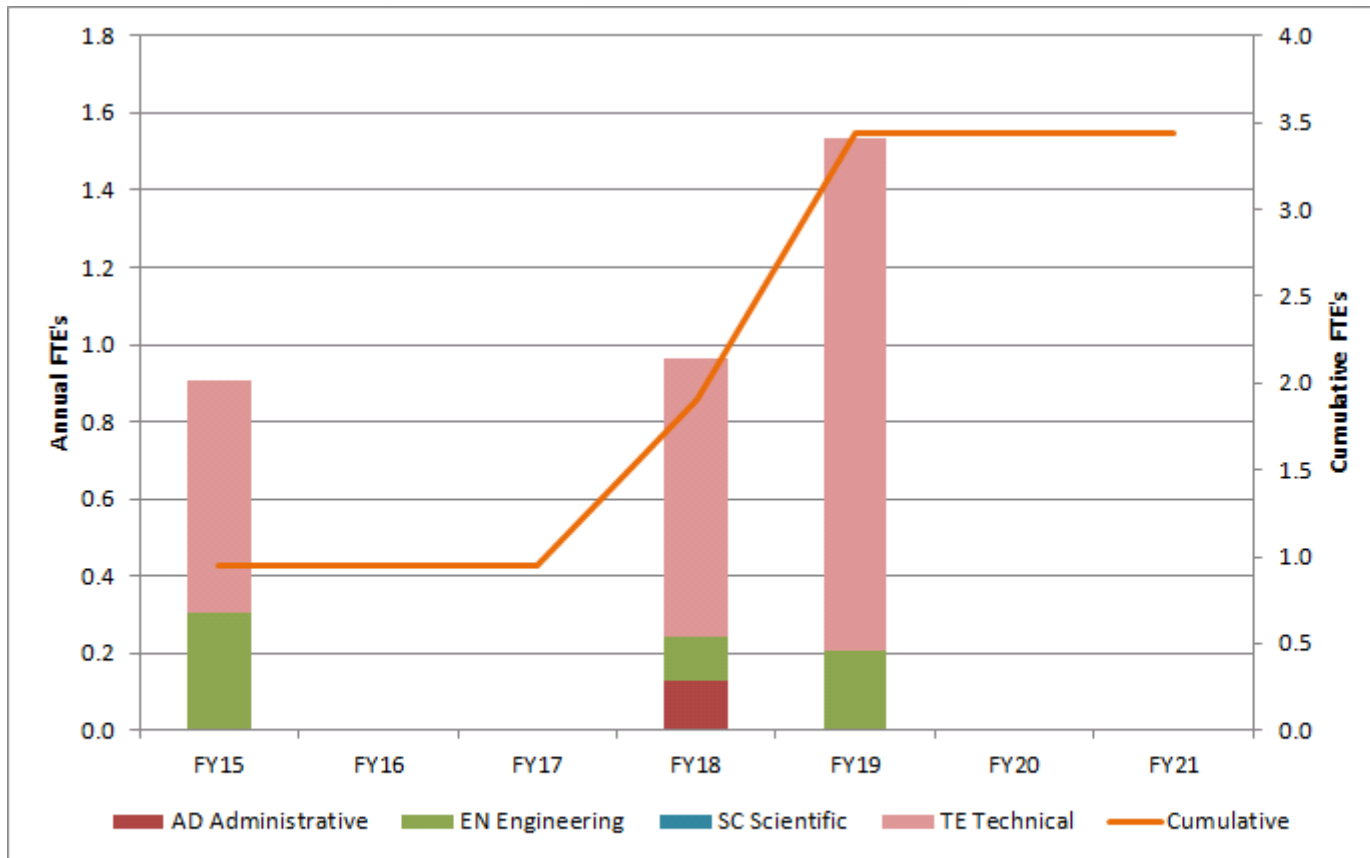

# Major Milestones

---

- 475.04.08 Field Mapping System
  - 001170 Final Design of Magnetic Field Mapping System Complete
  - 001310 Vendor for magnetic field mapping system purchased parts selected
  - 001360 PO issued for magnetic field mapping system purchased parts

# Schedule

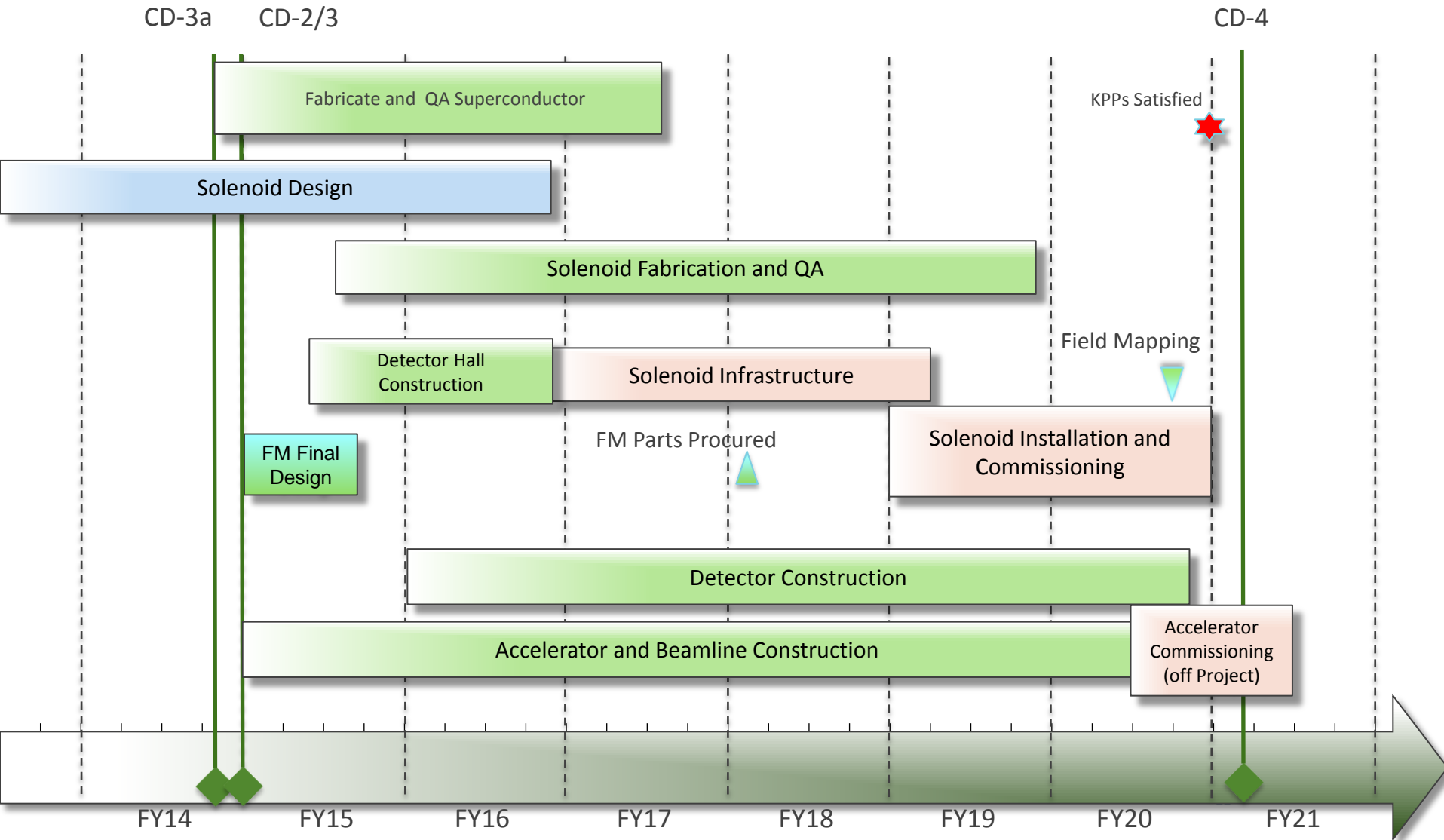

# Summary

---

- Field Mapping System preliminary design is in progress
  - Mapping is not on the critical path
    - In-situ sensors needed at end of TS construction
    - Other Mapping activities happen during Solenoid commissioning
  - DS is the most important, is the most advanced
    - Next focus on the daq & controls
  - PS Mapper
    - mechanical design following DS mechanical completion
- Field Mapping System is ready for CD2