

DAQ

Alan Prosser

Fermilab

DOE Review Laboratory Detector R&D

July 24, 2012



Comprehensive Approach to Tracking Detector R&D

Creating a tracking and trigger system that can withstand the projected HL-LHC luminosities is perhaps the most important detector challenge in the field of High Energy Physics.

There must be a comprehensive approach:

Sensor

Radiation hardness in new sensors (3D columnar + Diamond)

Front End

New ASIC developments to give integrated track segment information

L1 Trigger

Track trigger

Data Transmission

Multi-wavelength optical data links

Track Fitting

FPGA, GPU's and Associative Memory based on xTCA

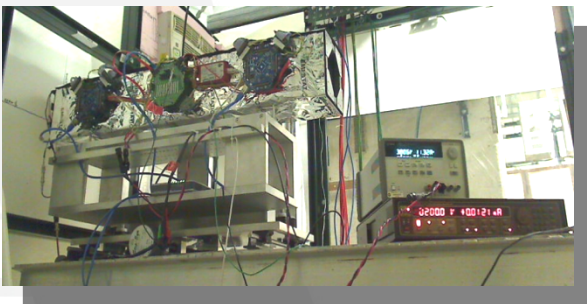

Compact And Programmable dataacquisition Node (CAPTAN)

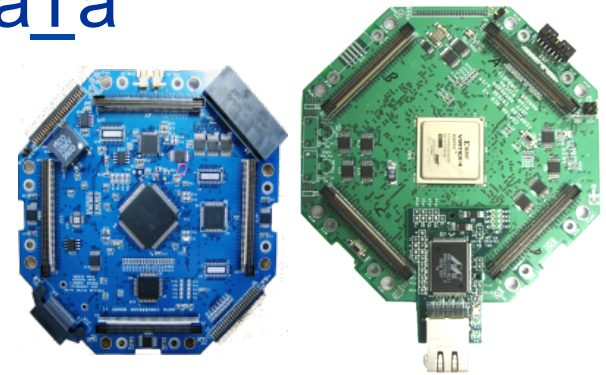

- **Motivation**

- **simple DAQ**

- It is 6" x 6" and, for many systems, the only external connections needed are a 3.3V power supply and a standard Ethernet cable.

- **flexible DAQ**

- The user can stack compatible boards in different combinations to give unique functionality.

- **scalable DAQ**

- In addition to the vertical stacking, the stacks can be repeated arbitrarily and connected with one or many PCs in an Ethernet network.

CAPTAN: Applications

- Developed in 2008/2009, the CAPTAN system was designed to handle common data acquisition, control, and processing challenges within high energy physics.
- Examples of such applications are tracker readout systems, R&D test stands, and parallel data processing.
- As the CAPTAN system is a modular system it can be used for a wide range of applications, from very small to very large.
- Quite a number of groups at Fermilab and other institutes in the US, China, and Europe have acquired the system for their test-stands. We work with them to provide hardware and software support.

CAPTAN: QIE10 Single Event Upset Testing

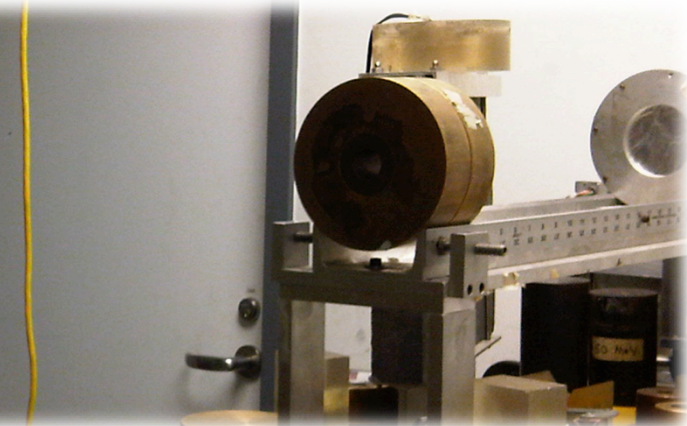
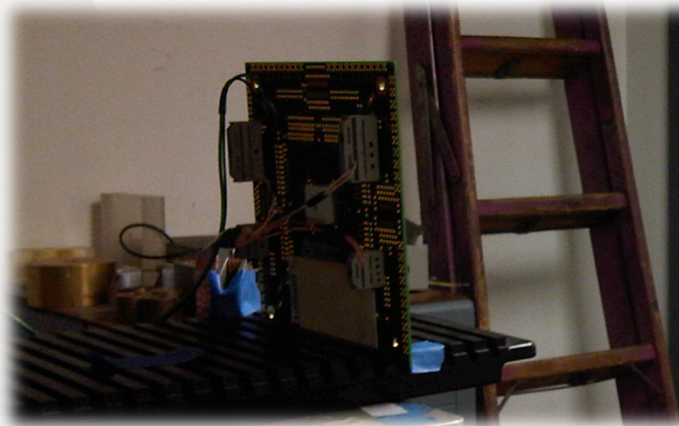
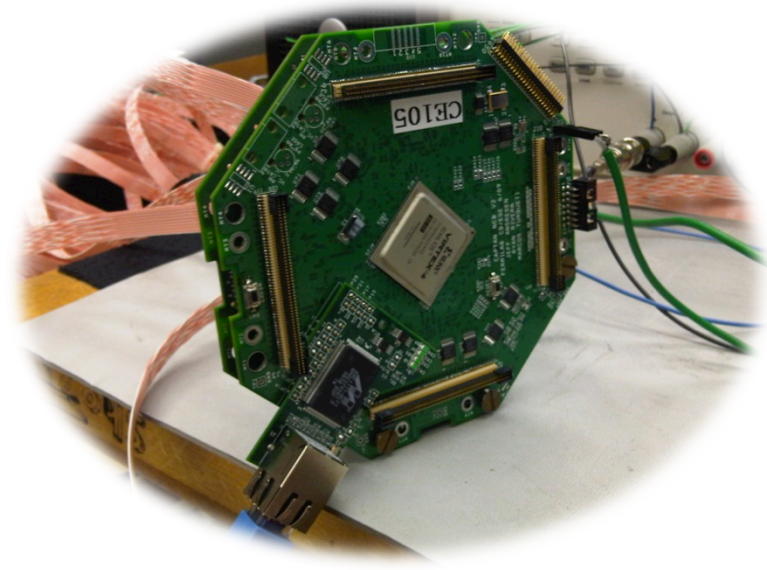
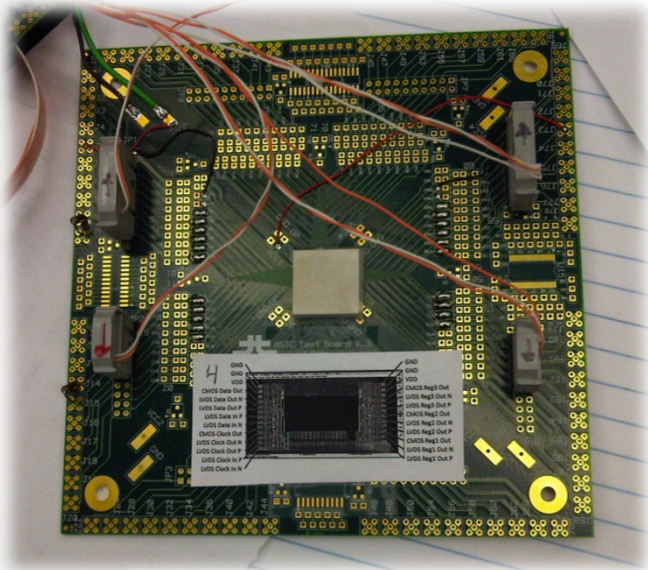

CAPTAN: 3D ASIC VIP Test-Stand

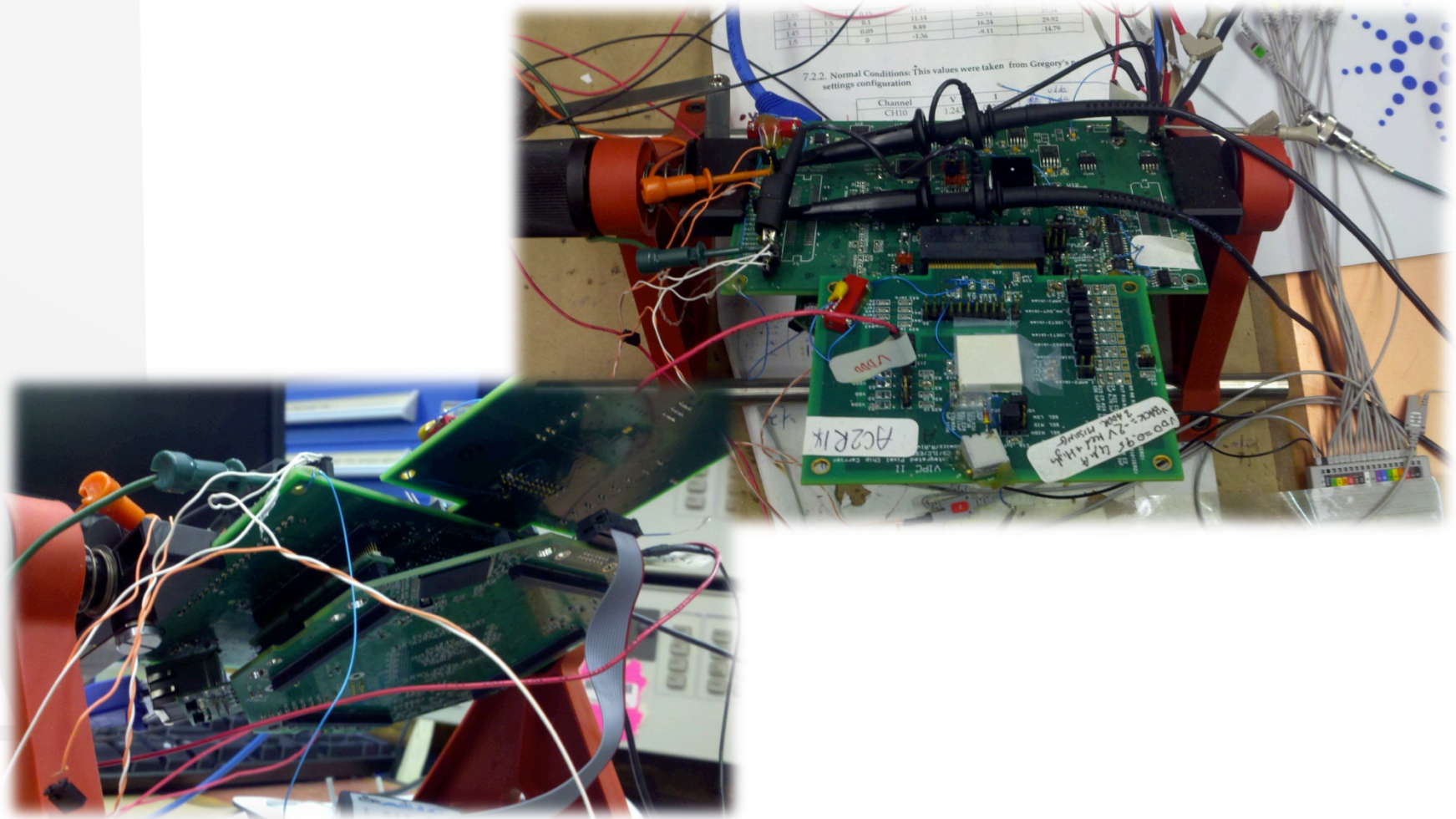

CAPTAN: MTEST Pixel Telescope

The CAPTAN pixel telescope is 8 silicon pixel planes leftover from CMS, with space for 2 DUTs in the middle. Pixel size is $100\ \mu\text{m} \times 150\ \mu\text{m}$. Data acquisition with the CAPTAN system.

Pixel Telescope
Frame

CAPTAN Stacks

Power Supply

DUT HV Supply

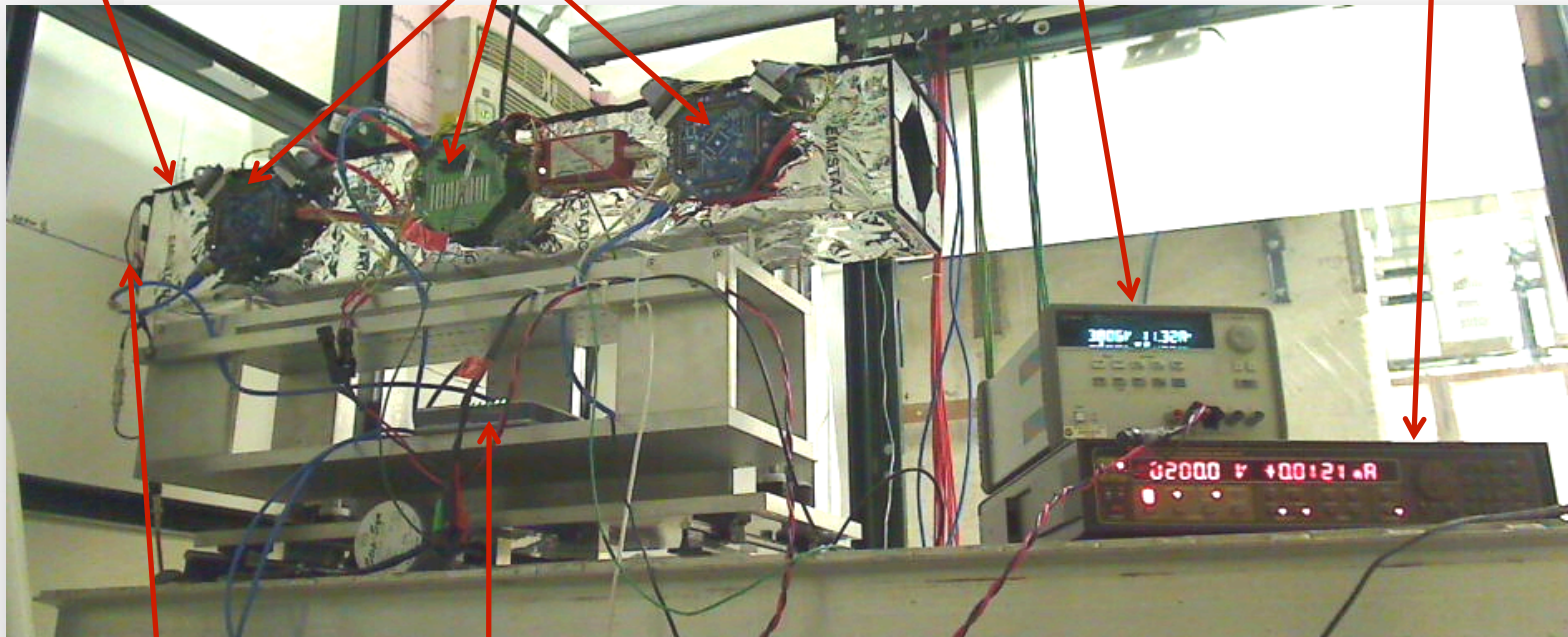

Scintillator

Ethernet Router

Telescope DAQ overview

- Hardware is based on the CAPTAN system which uses a gigabit Ethernet link to transfer the data.
- The software sits on Windows PC and is a suite of multithreaded applications.
- Can sustain up to few hundred thousands particle per 4-sec spill

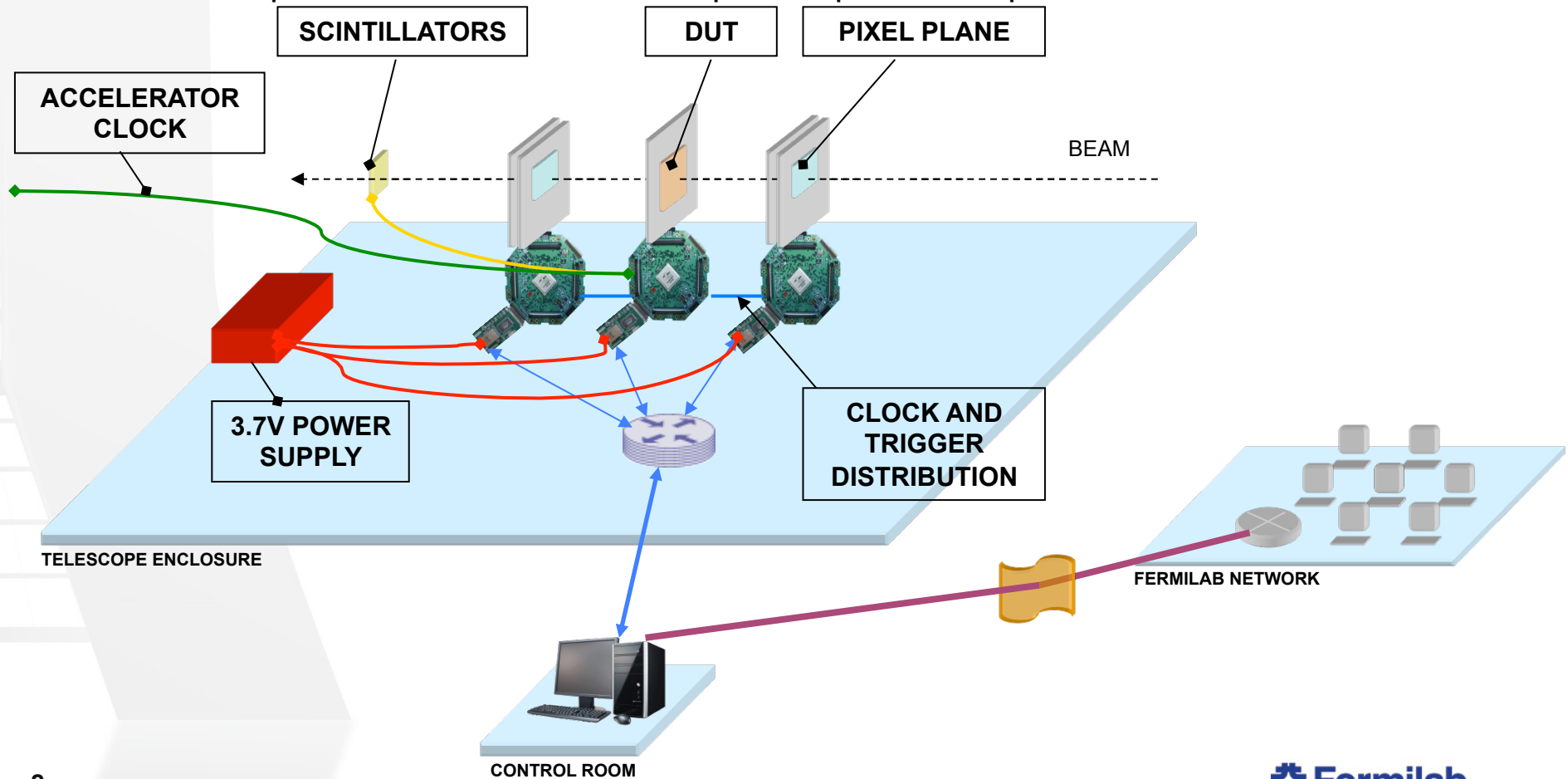

CAPTAN: Pixel Telescope Users

- Telescope is part of the FTBF facility and has been used by many experiments as a high resolution tracking tool to characterize different Detectors Under Test (DUTs)
- List of Fermi Test Beam Facility Experiments using the Telescope
 - T992 - Radiation-Hard Sensors for the HL-LHC (ongoing)
 - T995 - Scintillator Muon/Tail Catcher R&D with SiPM Readout
 - T979 - Fast Timing Counters – PSEC Collaboration
 - T1004 - Total Absorption Dual Readout Calorimetry R&D
 - T1006 - Response and Uniformity Studies of Directly Coupled Tiles
 - T1017 - CIRTE (COUPP Iodine Recoil Threshold Experiment)
- We are planning to upgrade the existing telescope to increase the overlap area between modules since many users preferred to have a wider coverage
- We will continue to support test beam experiments that want to use the pixel telescope

Particle fluence at HL-LHC

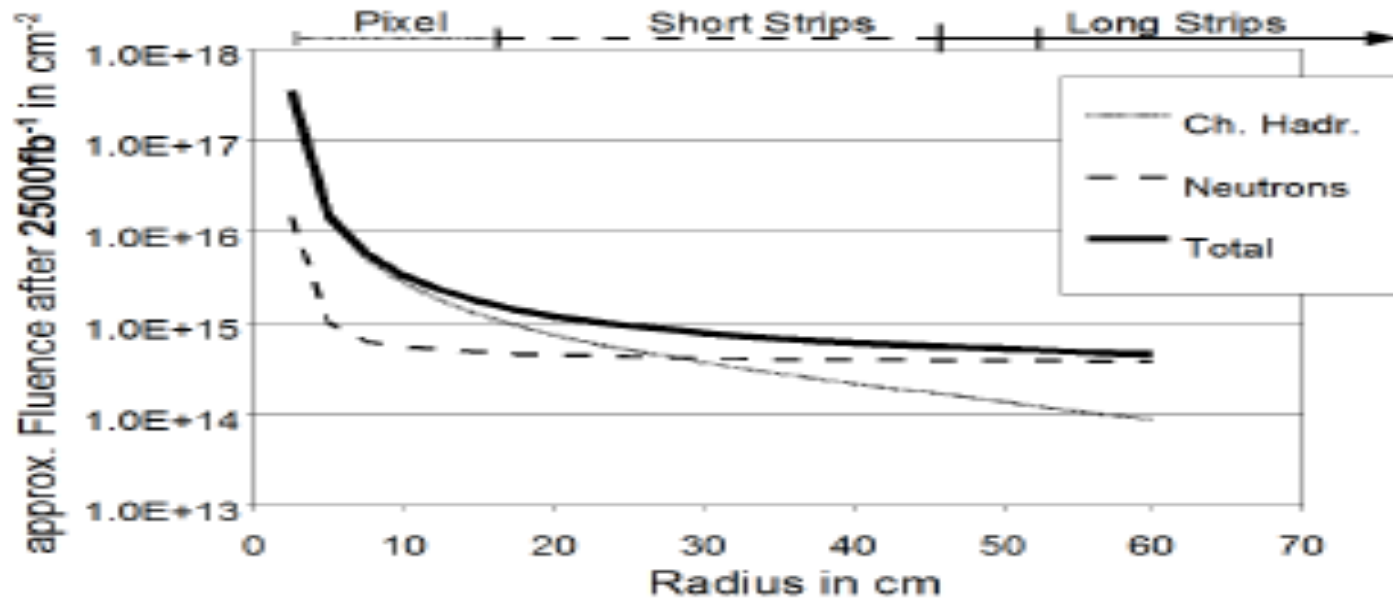

Figure 1: Estimated particle fluence at SLHC extrapolated from simulations for the CMS detector at LHC. [1]

For 2500 fb⁻¹ of data

Rad-Hard Sensor Testing Using CAPTAN

- Goal is to test new rad-hard sensor candidates for the HL-LHC vertex detector before and after irradiation:
 - Diamond sensors
 - 3D sensors
 - MCz planar silicon sensors
 - FZ planar silicon, p-type silicon
- Big global effort on Sensor R&D for the HL-LHC
 - RD42 (diamond)
 - RD50 (rad-hard sensors, mostly on silicon)
 - 3d consortium (3d sensors)
 - ATLAS, CMS, and LHCb effort
- What is unique about our effort is to test all sensor materials using the same readout electronics in the same environment and apparatus -> fair comparison of all candidates
- CAPTAN is used to readout the DUT both in bench test and beam test
- The institutes who have acquired CAPTAN also used it for their bench test
- Open to all, independent of their experimental affiliation or interest in any particular technology
- Our collaborators:
 - 3d silicon sensor: Purdue, SUNY, TAMU, INFN Torino
 - Diamond: Colorado, Rutgers, Syracuse, Tennessee, TAMU, UMiss, INFN Milano, INFN Lecce, Catania, Strasbourg
- Test beam at FTBF and irradiation at LANSCE
 - Fermilab arranged the test beam schedule, organized the test beam plan, shift, and data analysis and coordinated with Univ New Mexico on the irradiation test at LANL.

3D Sensors

- “3D” electrodes: **narrow columns along detector thickness,**
 - diameter: $10\mu\text{m}$, distance: $50 - 100\mu\text{m}$
- **Lateral depletion: great for rad-hard**
 - Lower depletion voltage
 - Cooling
 - HV power distribution
 - Fast signal
 - Reduced bunch crossing, pileups, rate

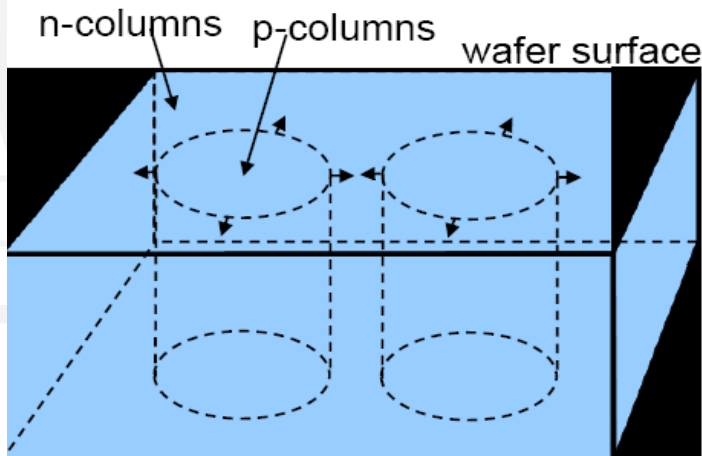
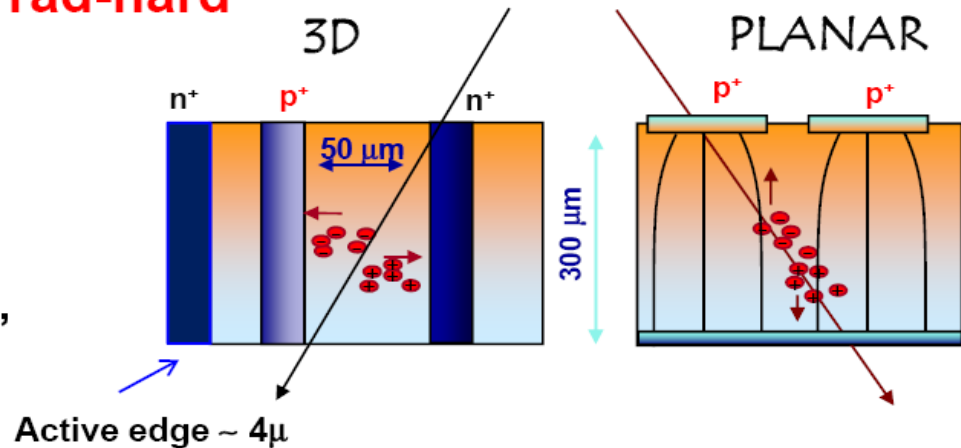

- 3D detectors also allow the implementation of the “Active Edge concept”
- Interest in the Forward physics community
- Active Edge concept can lead to Improving layout geometry which is of general interest

Diamond sensors

- Big differences in charge collected are observed between mono-crystal and poly-crystalline diamonds
- These studies show that in order to use effectively the lower cost and much bigger dimensions poly-crystalline sensors it is mandatory to fabricate a new readout chip operable at $\sim 1000 e^-$ threshold

Cell charge distribution - Monocrystal

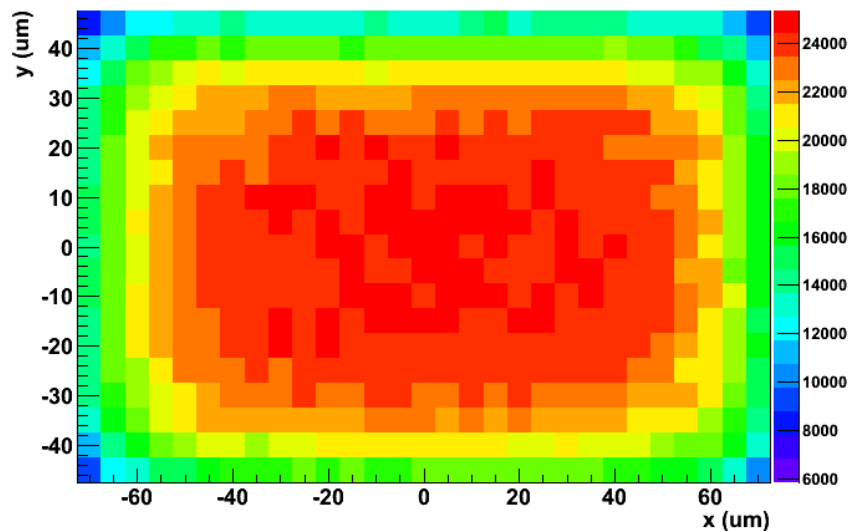

Cell charge distribution - Polycrystal

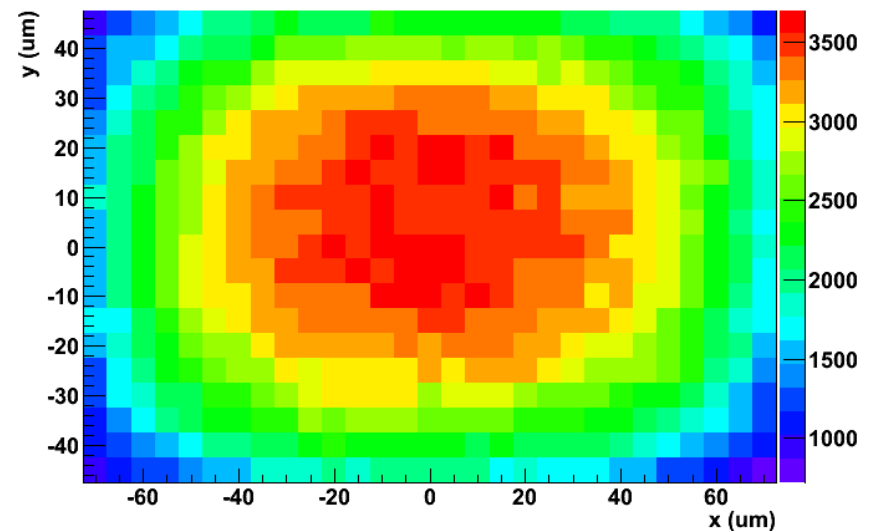

Pixel cell collected charge in mono-crystal (left plot) and poly-crystalline (right plot) sensors at 500 V

Rad-Hard Sensor Studies Summary

- We have collected many useful results on 3d, diamond, and start to have some results on 200 μm thick planar silicon before and after irradiation
- Some conclusions could already be drawn based on these studies
 - 3d: good performance after irradiation (up to $5e15$); no Lorentz effect; yield limits size of the module; cost on the other hand is reasonable; 2E/4E better than 1E
 - Diamond: poly-crystalline has to be used for a reasonable size pixel detector; Could get a CCD of $>250\mu\text{m}$ ($>8\text{k}$ electron signal); cost is still high c.f. 3d and planar; charge sharing needs to be understood; assembly of large size modules still need some effort
 - Thin planar: we have limited samples and are experimenting with n on p sensors.

Next Steps for CAPTAN and Sensor testing

- For CAPTAN:
 - Port software to LINUX; exploit parallel processing power, and (continue) μ TCA integration
 - Provide user support for their applications
 - Work with possible users on new applications
- Rad-hard sensor testing
 - Continue testing of various sensor candidates working together with our collaborators
 - Study new sensors (bench, beam, irradiation)
 - Clear from our tests so far is to design a new readout chip that can operate at lower thresholds and have smaller pixel dimensions. (see Ron's talk)

xTCA in HEP

- **TCA (Telecommunications Computing Architecture)**
 - Spec put forth by PICMG (PCI Industrial Computer Manufacturers Group: a consortium of over 250 companies).
 - xTCA encompasses MicroTCA and ATCA.
- Large experiments are planning to use xTCA for their DAQ solutions:
 - CMS
 - ATLAS
 - LHCb
 - NLC Accelerator Control
 - Mu2e (some interest in using μ TCA)
- Fermilab is a key member in the PICMG subcommittee to define the specifications of xTCA for physics
 - Two specification documents have been approved and another one being prepared
- Fermilab serves as the portal for our US collaborators on different experiments to access specifications on xTCA published by PICMG

VME

- Number of new developments is decreasing, sales are still constant
- A lot of I/O modules are available
- First developed in 1981
- Bus technology has speed limitations
- Wide busses create a lot of noise in analog channels
- No standard management on crate level
- No management on module level
- So far no extension bus survived
- One damaged bus line stops a whole crate
- Address and interrupt misconfigurations are hard to find

vs

xTCA

- Scalable modern architecture
 - From 5 slot μ TCA ... full mesh ATCA
- Gbit serial communication links
- High speed and no single point of failure
- Standard PCIe, Ethernet (, SRIO) communication
- Redundant system option
- 99.999% availability is possible
- Well defined management
- A must for large systems and for high availability
- Hot-swap
- Reliability: safe against hardware damage and software crashes

μ TCA and CAPTAN Integration

- Completed a test beam project at Fermilab
 - Real-time event assembly conducted in MicroTCA form factor.

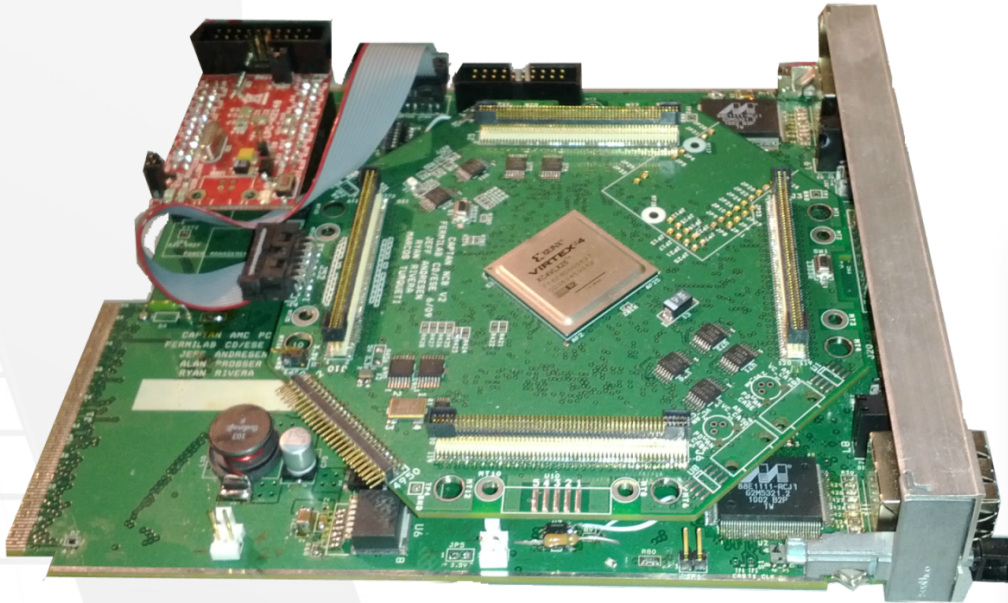

Telescope with MicroTCA Overview

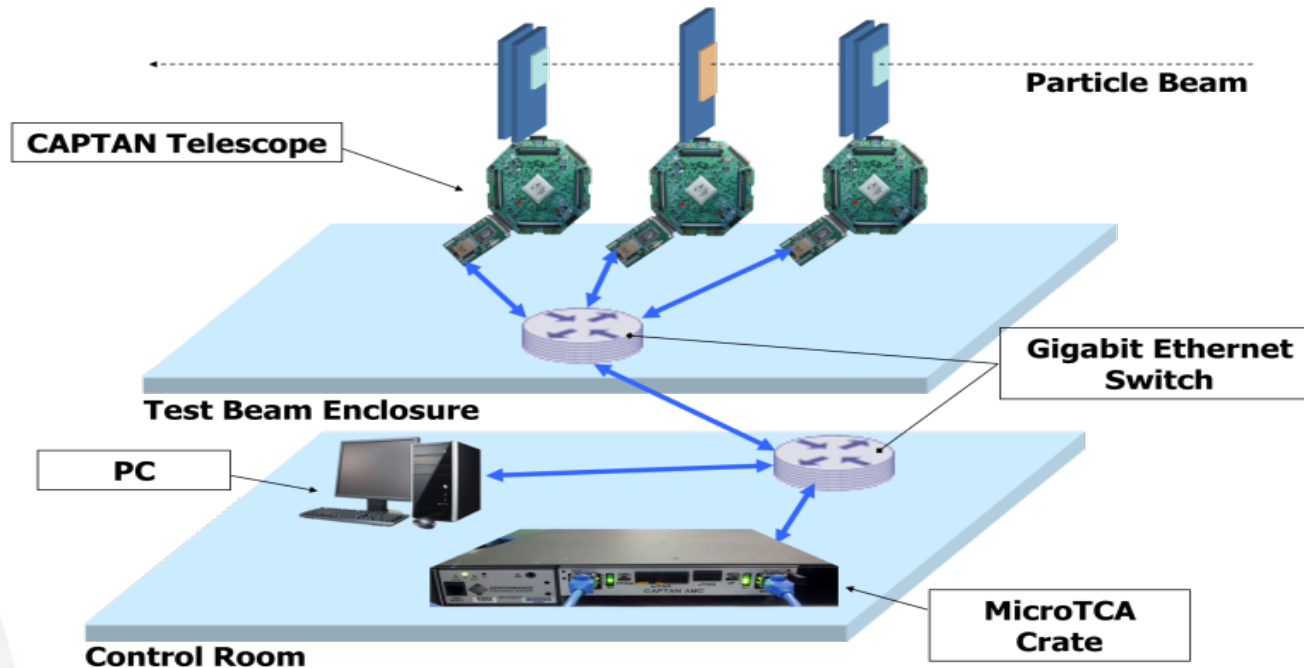

Took data running parasitically during the last days of test beam run in April 2012

Complete agreement between data assembled by the PC and the μ TCA/AMC card with the limited data (~5k events) that we collected

Real-time event building is possible with our AMC card

μ TCA Future Plan

- MicroTCA.4 Standard
 - Specification finalized in 2012 for the physics community.
 - We are working on a new board to meet MTCA.4 specs for a real-time track reconstruction application besides studying with much higher statistics the event building
 - Combine with the Optical data link work to produce a high rate DAQ system.



8U 12-slot MTCA.4 shelf

U.S. R&D on High Data Rate Optical Links

- Sub-Detectors for the HL-LHC will require more on-detector communications bandwidth than is available from current optical transceivers. Examples are: ATLAS/CMS Track Trigger and ATLAS Calorimeter
- Increase in on-detector bandwidth requirements must be provided within thermal (low power) and mass (small footprint) budgets with rad-hard components
- In 2008, Fermilab joined the CERN organized Versatile Link Project. Our task is to test commercial back-end components, certify their performance for the use of HL-LHC experiments, develop specs, and prepare QA and test documents.
- **In 2010, Fermilab initiated a U.S. effort on high data rate optical links with collaborators from national laboratories, universities, and private industry**
- Research Areas:
 - Custom Small Form Factor Rad Hard Array Transmitters
 - Miniature Optical Modulators with Wavelength Division Multiplexing (WDM)
 - Free Space Optical Transmission

DOE: CDRD Proposal

High Data Rate Links for Collider Experiments

- **Integrated Optical Modulators**

“to investigate and develop two alternative modulation methods that are based on indirect modulation of the optical signal and are applicable to longer wavelengths (Mach-Zehnder and Electro Absorption Modulators)”

Collaborators: Argonne, University of Minnesota

- **120 Gbps Parallel Links**

“to develop a parallel optical transmitter to support the deployment of a low mass 120 Gbps data links based on industry standards”

Collaborators: Fermilab, Southern Methodist University, Ohio State University

- **Free Space Optical Links**

“to design and develop a free-space optical link for trigger and data extraction”

Collaborators: ANL, Vegawave

This proposal has collaborators from both ATLAS and CMS. It was approved for funding in Spring 2012.

Due to funding limits, the last project was deferred from the revised proposal. Fermilab remains committed to exploring this approach.

Parallel Optics Components

Testing, Specifications, and Hardware Development

Test Results: 5 Device Types from 3 Vendors

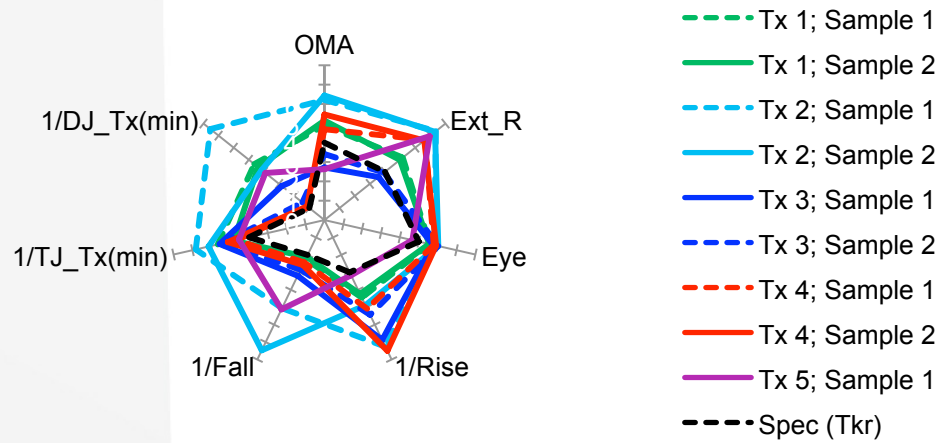

Channel Performance Specs.

Measurement	Norm
OMA	-3.6 dBm*
Ext. Ratio	3.0 dB
Tx. Eye Opening	60% of OMA
Tx Rise Time	70 ps
Tx Fall Time	70 ps
Tx Total Jitter	0.25 of UI
Tx Deterministic Jitter	0.12 of UI

*Tracker Grade Spec

Custom Optical Mezzanine Cards

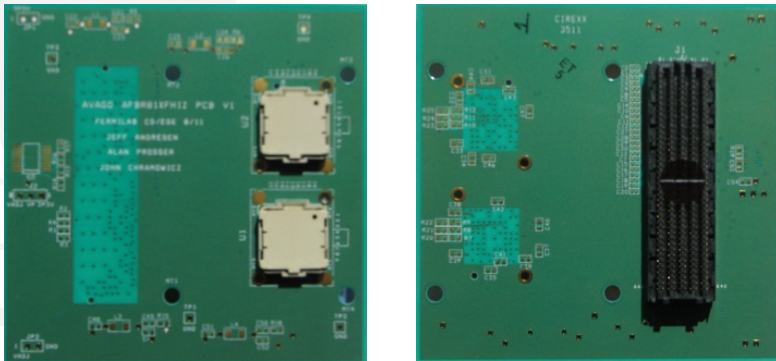

Contributions in Parallel Optics for HEP:

Characterization of COTS and Emerging Devices
Development of Channel Specifications for HEP
Design and Development of Pluggable Optical Modules (for device characterization and customer applications)

High Data Rate Links for Collider Experiments

Rad Hard Array Transmitter Devices

VCSEL Electrical Interface (Tx)

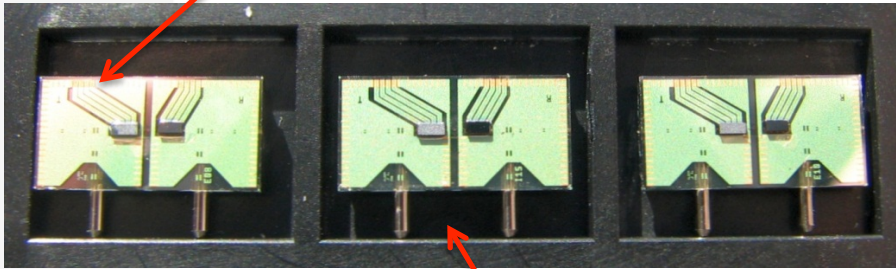

MT Optical Connection

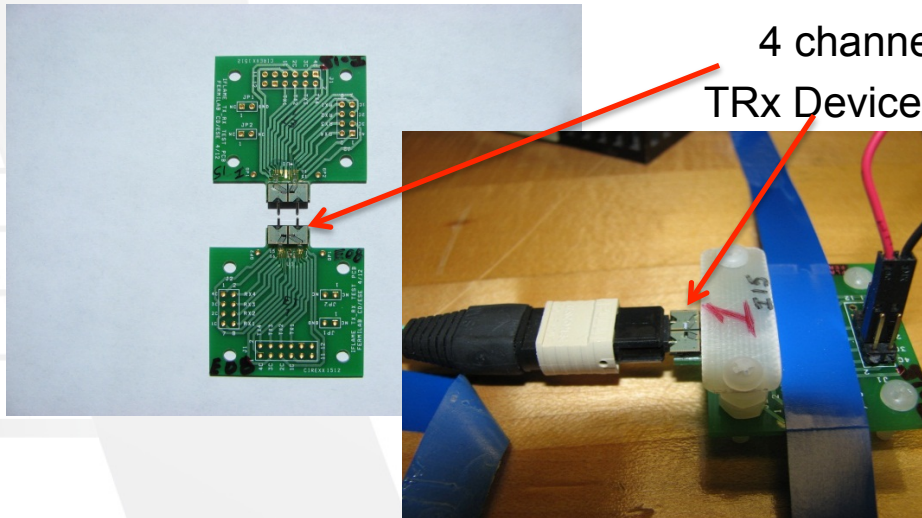

4 channel
TRx Devices

Fermilab Array Test Cards

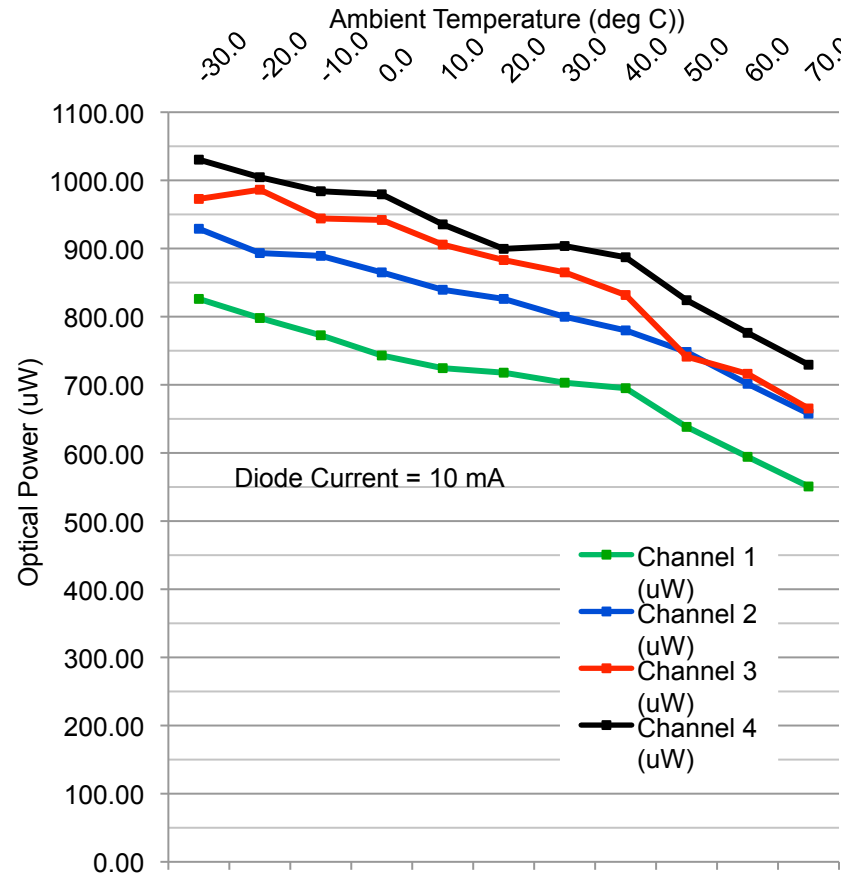

Tx Array Testing (DC Characterization)

Free Space Cable-less Readout for HEP

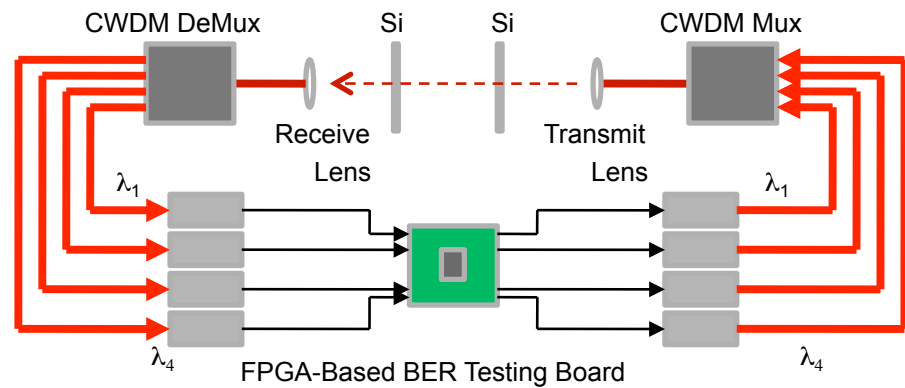
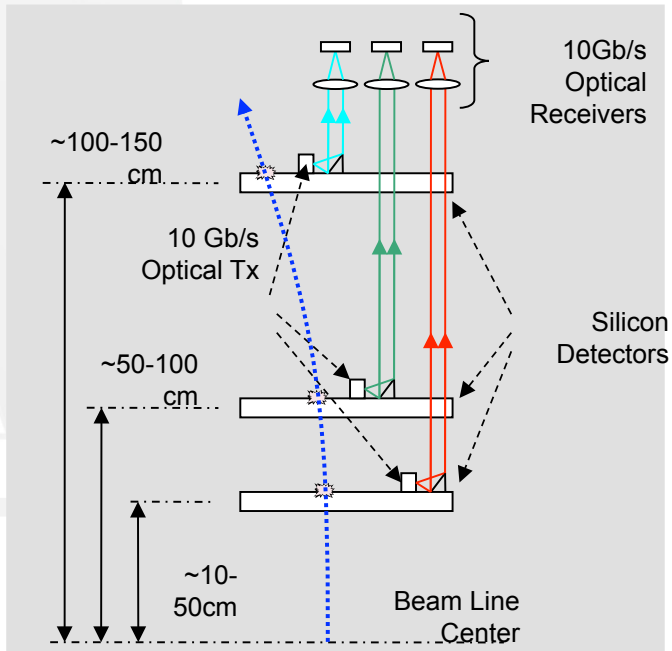
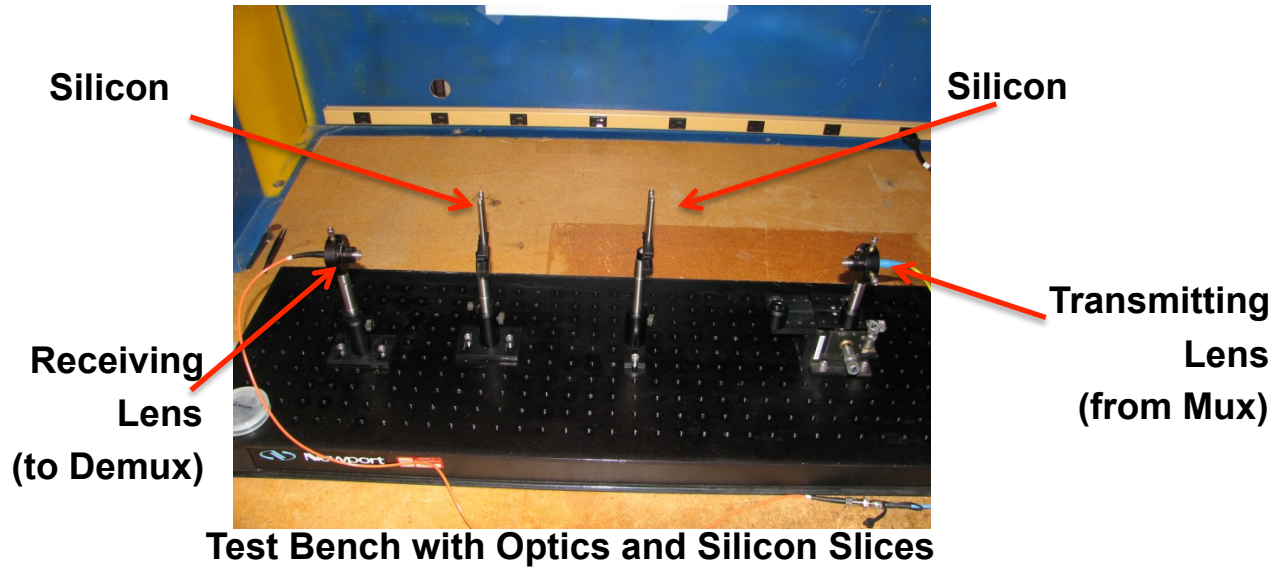

- Optical fibers removed from detector volume
- Transmission through free space or silicon
- Error free transmission at 4 Gbps for 48 hours.

Optical Modulation with WDM For HEP Readout

System Concept

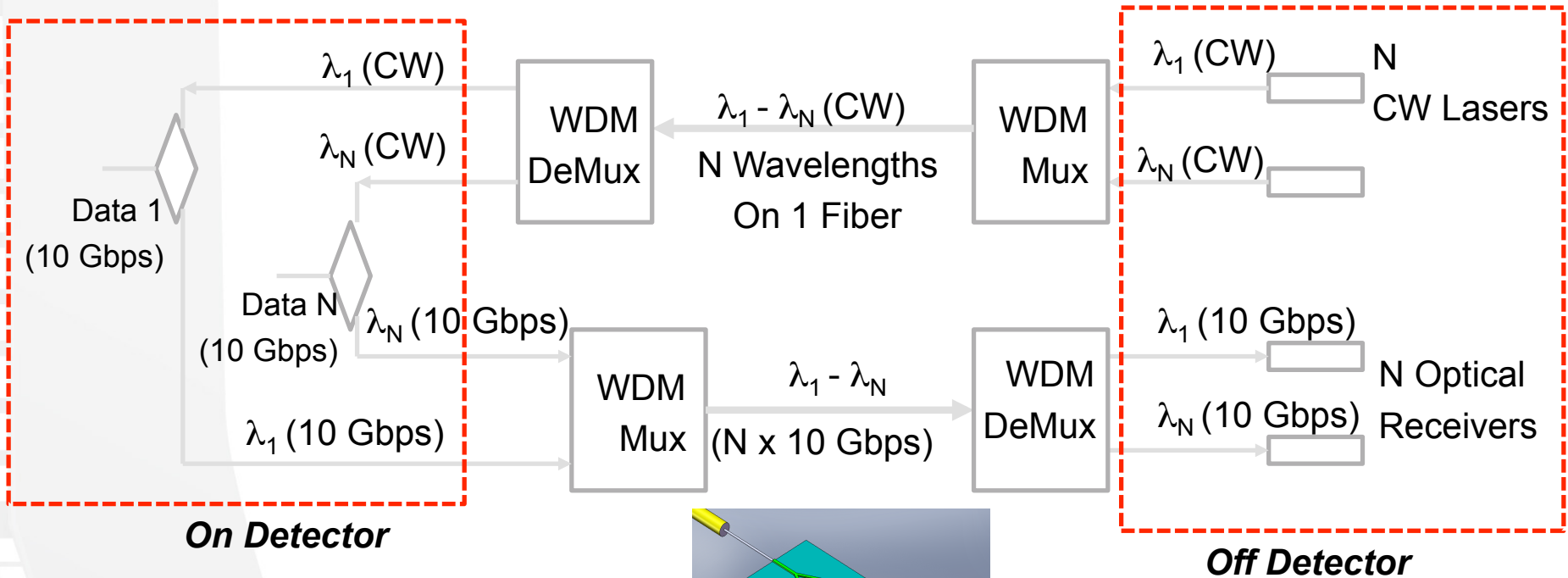

Successfully getting seed grant money from UC to support this R&D



=

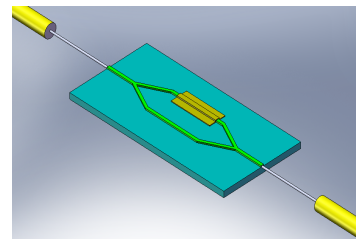

Mach-Zehnder Intensity Modulator

Total number of channels is scalable from 1 to 72 channels covering wavelengths from 1519.48 nm to 1577.03 nm with spacing of 100 GHz between adjacent channels.

Future Directions of Optical Links

- Custom Small Form Factor Rad Hard Array Transmitters
 - DC (Optical)testing of custom optical assemblies (including irradiation)
 - Testing of array laser drivers and serializers
 - Integration of optical assemblies and ASICs for transmitter testing
- Miniature Optical Modulators with Wavelength Division Multiplexing
 - Discrete component testing and system requirements
 - Specification of necessary subcomponents (lasers, multiplexers, de-multiplexers, beam splitters, PM fiber, modulators)
 - Integration of subcomponents (Silicon Optical Bench, Silicon Photonics)
- Free Space Optical Transmission
 - Study of optical requirements for detector geometries (beam divergence, mechanical and thermal stability)
 - Procurement of sample devices (lasers, ball lens, receivers) and assembly of test system with detector geometry and components

Summary

- We have accomplished a lot in our DAQ related R&D effort during the last three years
- Established collaboration/user support on CAPTAN, Rad-hard sensor R&D, and Optical links.
- We have a good plan for the next three years
 - Develop 120 Gbps optical data links
 - Identify the best sensor technology for HL-LHC
 - Start integration of xTCA with optical links
- With more funding, we could
 - Continue our effort on free-space optics
 - Develop a high rate readout system for the new pixel ASIC
 - Combine our integration effort on xTCA/optical link with the Track trigger effort

BACKUP

CAPTAN Core Boards



“Green Board”
NPCB – Node Processing
and Control Board

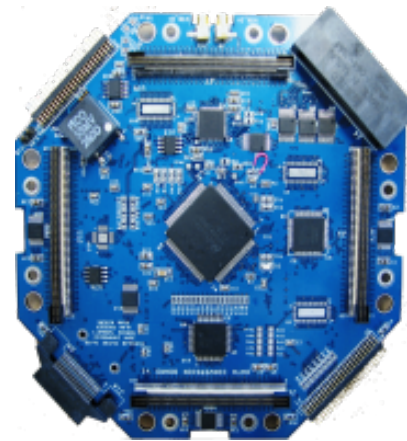

“Blue Board”
DCB – Data
Conversion Board

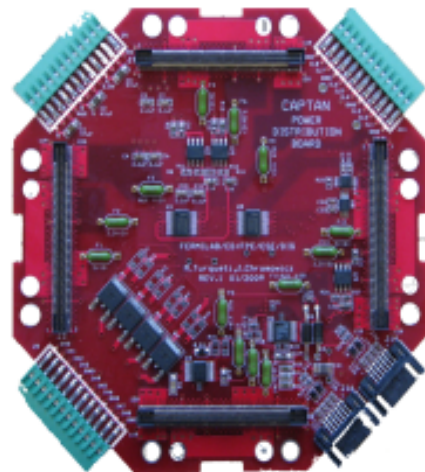

“Red Board”
PDB – Power
Distribution Board

IHEP Telescope - Beijing

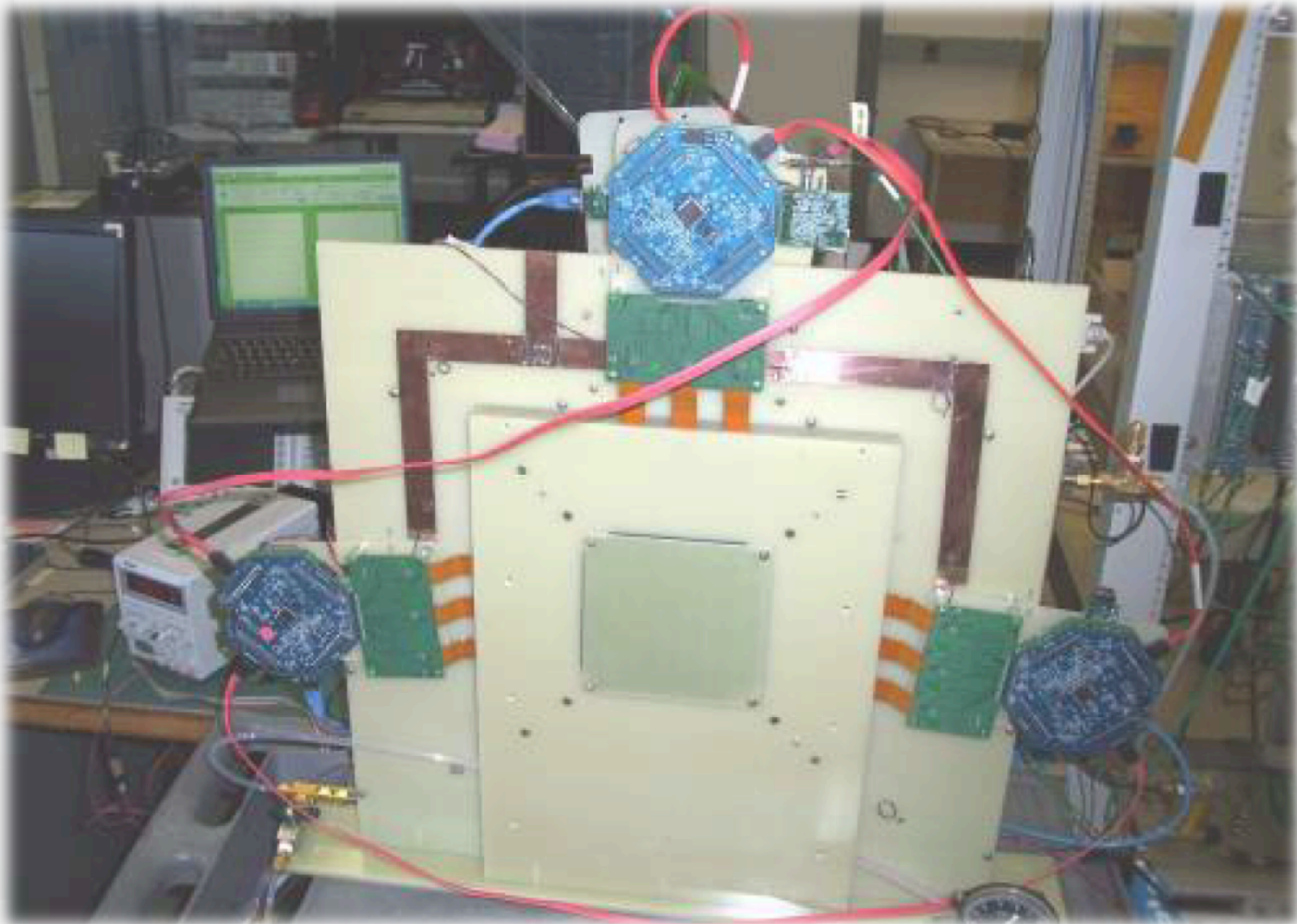

CAPTAN User Community

- Fermilab
- Brown
- Purdue
- Colorado
- Milano
- Lecce
- IHEP
- Syracuse

Charge Performance of Mono Sensors

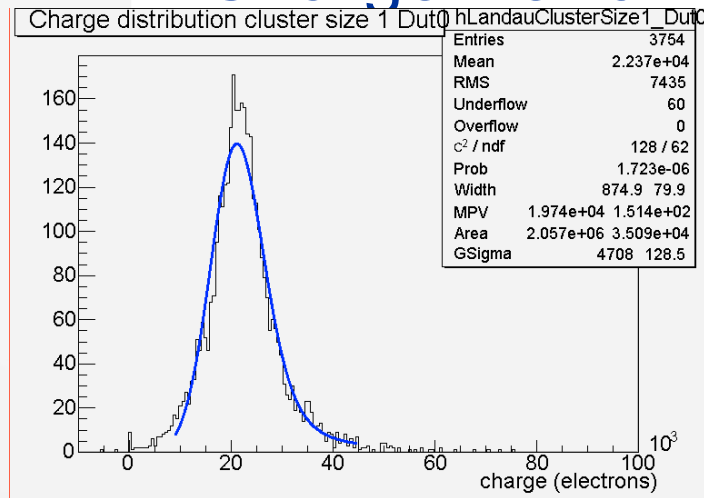

- **PLT S32A** – Produces 22370 e⁻ on average (24% more than expected). Calibration issues? Under investigation.

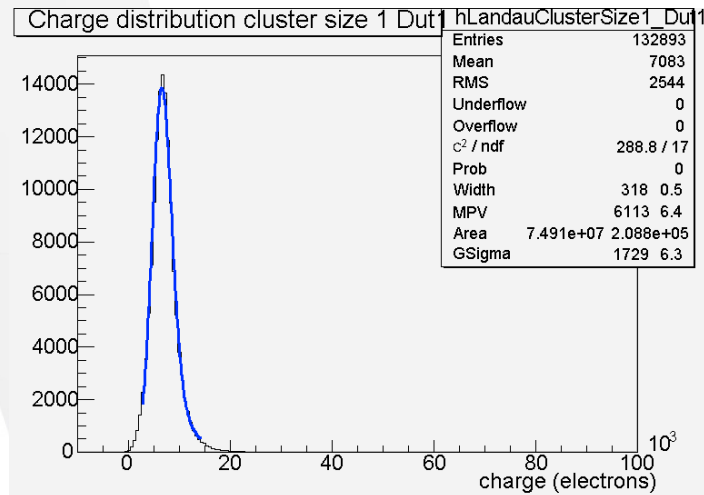

- **E6-DDL-M1** – Produces 7080 e⁻ on average. About 50% of what was expected (from test bench measurement after irradiation). Will investigate further at CU (arrived freshly bumped one day before end of run).

Charge Performance of Irradiated 3D

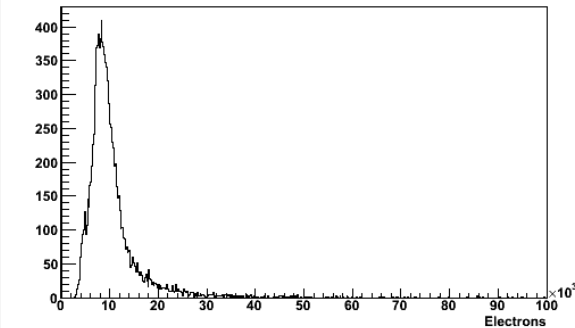

- **FBK_1E_1** – 1E sensor.
5E15 p/cm²
Produces ~10000 e⁻

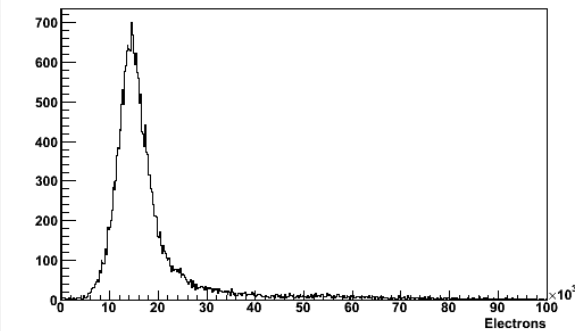

- **FBK_2E_9** – 2E sensor.
1E15 p/cm²
Produces ~16000 e⁻

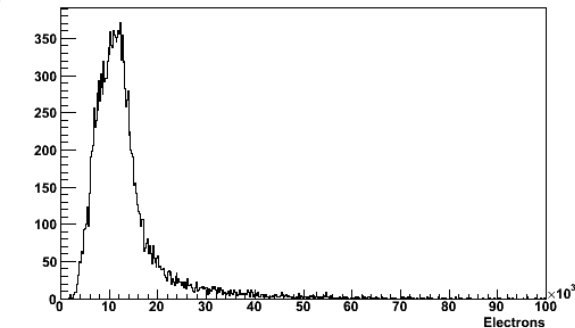

- **CNM12-2_75B** – 1E sensor.
5E14 p/cm²
Produces ~13000 e⁻

Charge Performance of Irradiated Polycrystalline Diamond Sensor

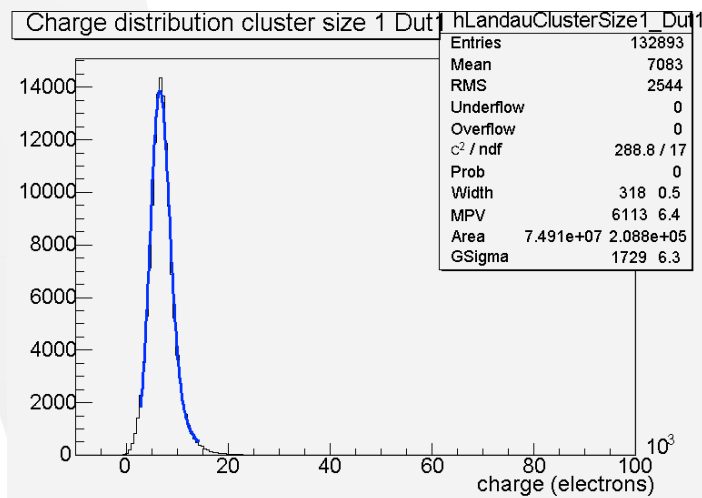
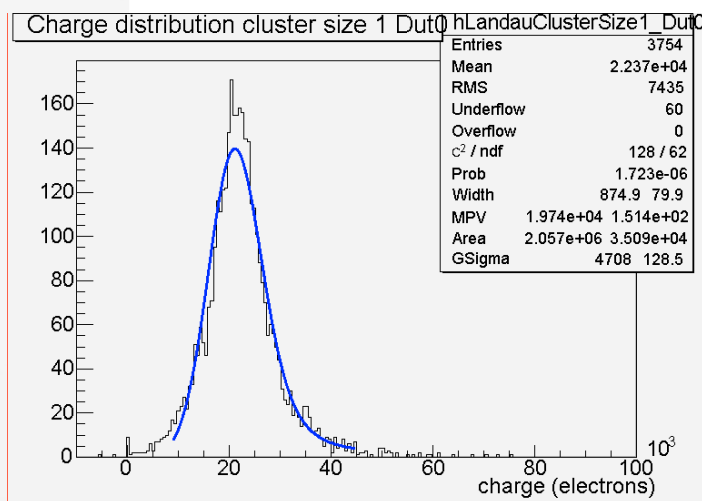

- **LC750** – Puts out $\sim 4730 e^-$ on average. Not out of line with expected degradation from $7270 e^-$ for irradiation of $3.2 \times 10^{14} \text{ p/cm}^2$.
- Efficiency $\sim 81\%$ when poorly bumped part of ROC excluded (issue known before irradiation - 1st try at pixelation with full 4k mask). Consistent with amount of charge put out by sensor – clear we need a ROC with lower thresholds for diamond sensors (especially after irradiation).

High Data Rate Links for Collider Experiments

4x Tx Device L-I Irradiation Testing

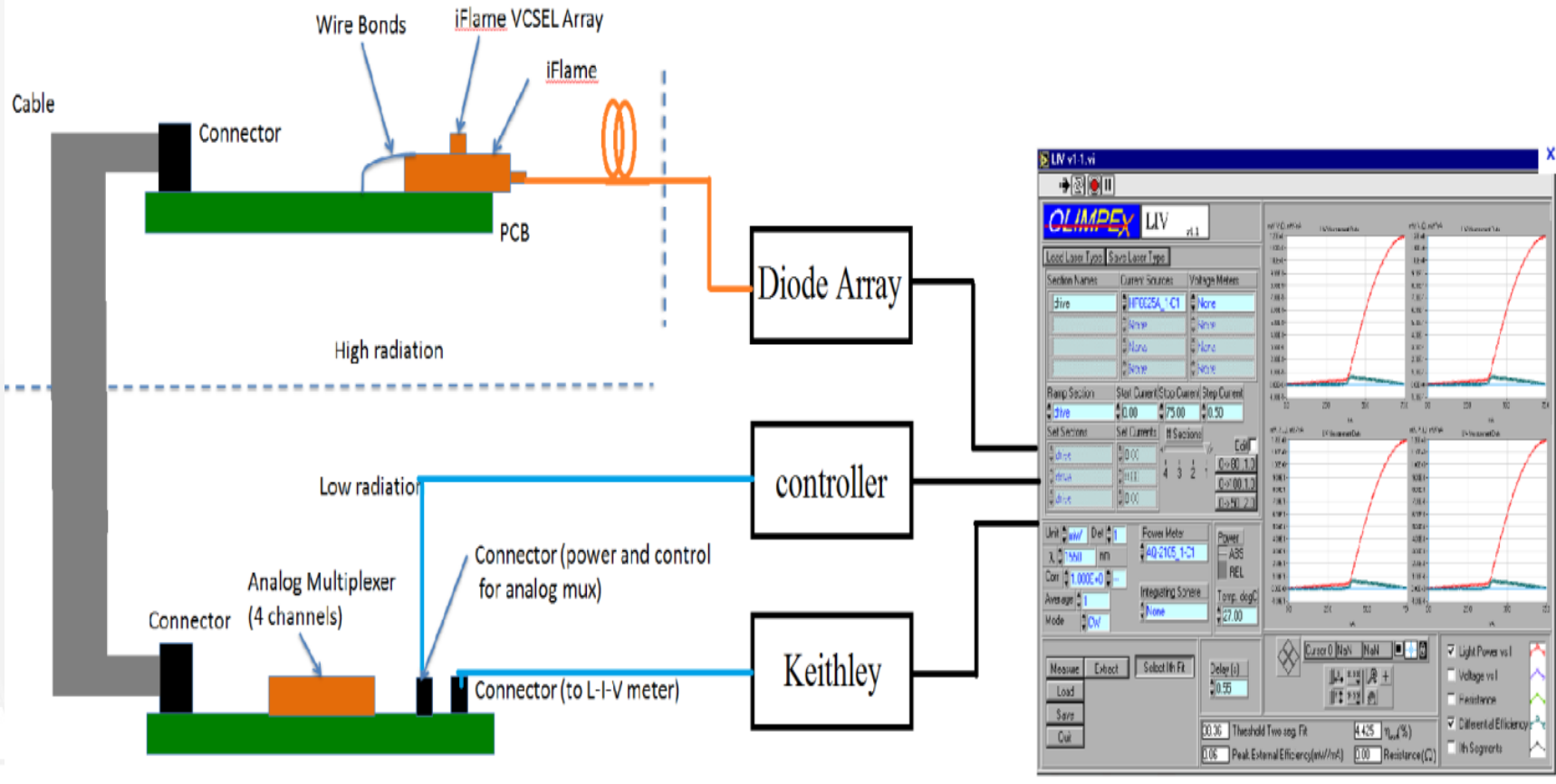

July 2012 Proton Beam Testing at Massachusetts General Hospital

Optical Modulation with WDM For HEP Readout

Collaborators and Work Plan

- Argonne National Laboratory
 - Test stand development for modulator radiation testing
 - Characterization and radiation testing of commercial modulators ,modulator drivers, and links
- Fermi National Laboratory
 - Multi-Gbps electronics design and test for optical communications
 - Develop PCBs and test stands for modulator and driver electronics
 - Complete characterization of electrical and optical channel performance
- University of Chicago
 - Infrastructure for irradiation studies
 - Establish HL-LHC environment in enclosure M3 near pinhole collimator in FNAL meson line
 - Fabrication of control electronics, radiation and SEU monitoring and loopback communications
 - Design studies for a driver ASIC
 - Feasibility studies and protocols including implementation in 90 nm technology
 - Layout of driver coupling to FPGA capable of achieving >15 Gbps
- Industrial Partner: Vega Wave Systems
 - Complete semiconductor fabrication facilities in West Chicago, IL
 - Design and characterization of compound semiconductor Mach-Zehnder Modulator
 - Selection of suitable COTS components for WDM system architecture