

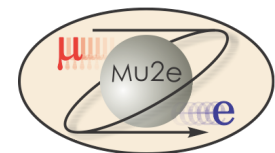

Mu2e Cosmic Ray Veto

8.2 Mechanical Design

E. Craig Dukes
Level 3 Manager
October 21, 2014



Outline

- Organizational Breakdown
- Design
- Changes Since CD-1
- Value Engineering Since CD-1
- Performance
- Remaining Work Before CD-3
- Quality Assurance
- ES&H Issues
- Risks & Opportunities
- Costs
- Major Milestones
- Schedule
- Summary

Organizational Breakdown

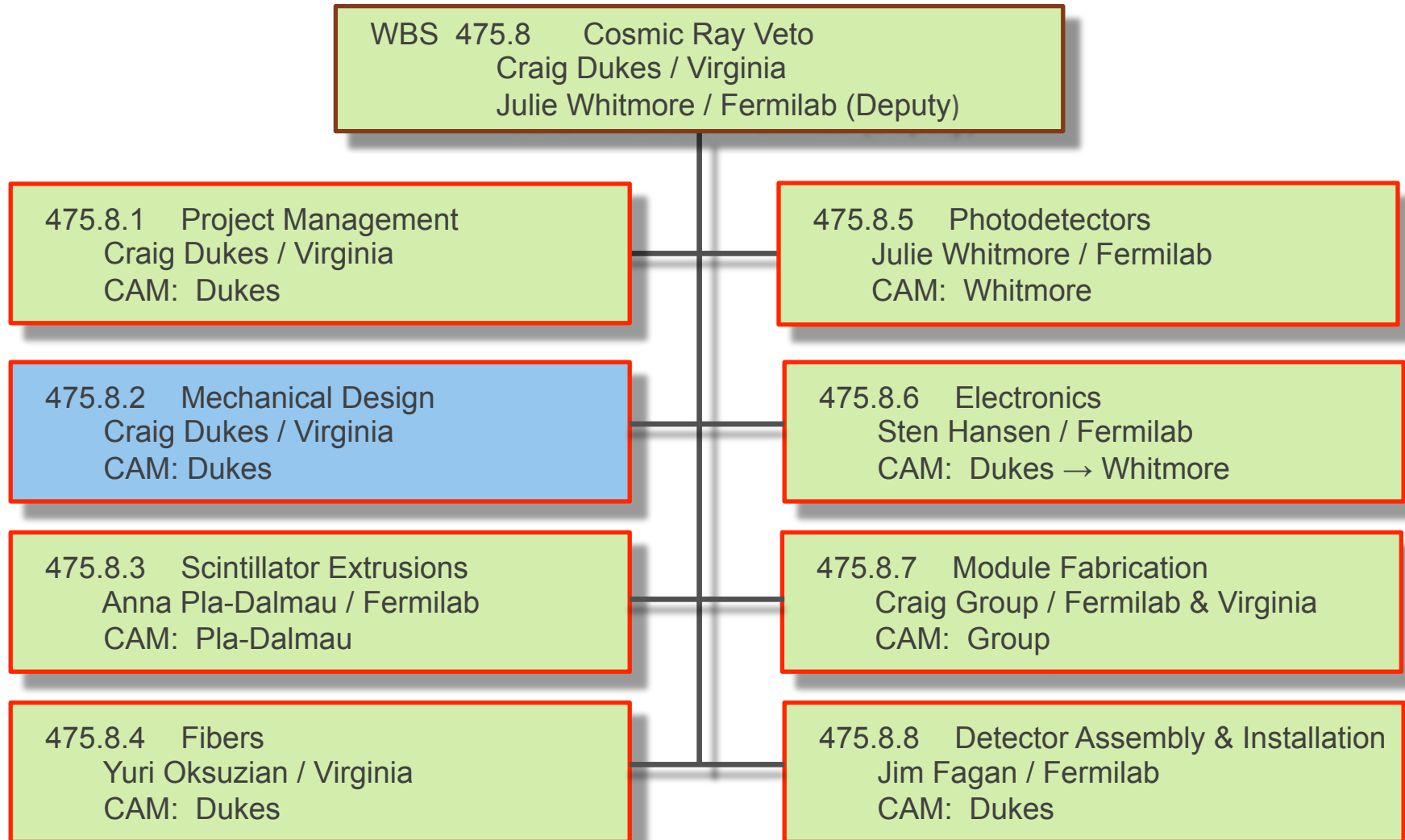

Organizational Breakdown

WBS 8.2 Mechanical Design Craig Dukes / Virginia

8.2.1 Detector Design

This covers all aspects of the design of the self-contained CRV modules to be mounted on the detector support structure, and the design of the structure that supports the modules. It includes: (1) the support structure for the counters and the absorber; (2) the counter parts, including the mounting fixture for the photodetector and flasher system; (3) the support structure for the readout electronics; (4) the structure needed for the external support of the modules; and (5) transport and installation jigs and other associated infrastructure.

8.2.2 Fabricate & Test Counter Prototypes

This covers the fabrication and testing of the counter prototypes to validate that they meet the requirements.

8.2.3 Cosmic Ray Veto Simulations

This task covers the simulations needed to determine the design and requirements of the cosmic ray veto, including: (1) the required coverage of the cosmic ray veto; (2) the required efficiency of the cosmic ray veto and how it can be achieved; and (3) the background rates in the cosmic ray veto.

Mechanical Design

Layout of the CRV

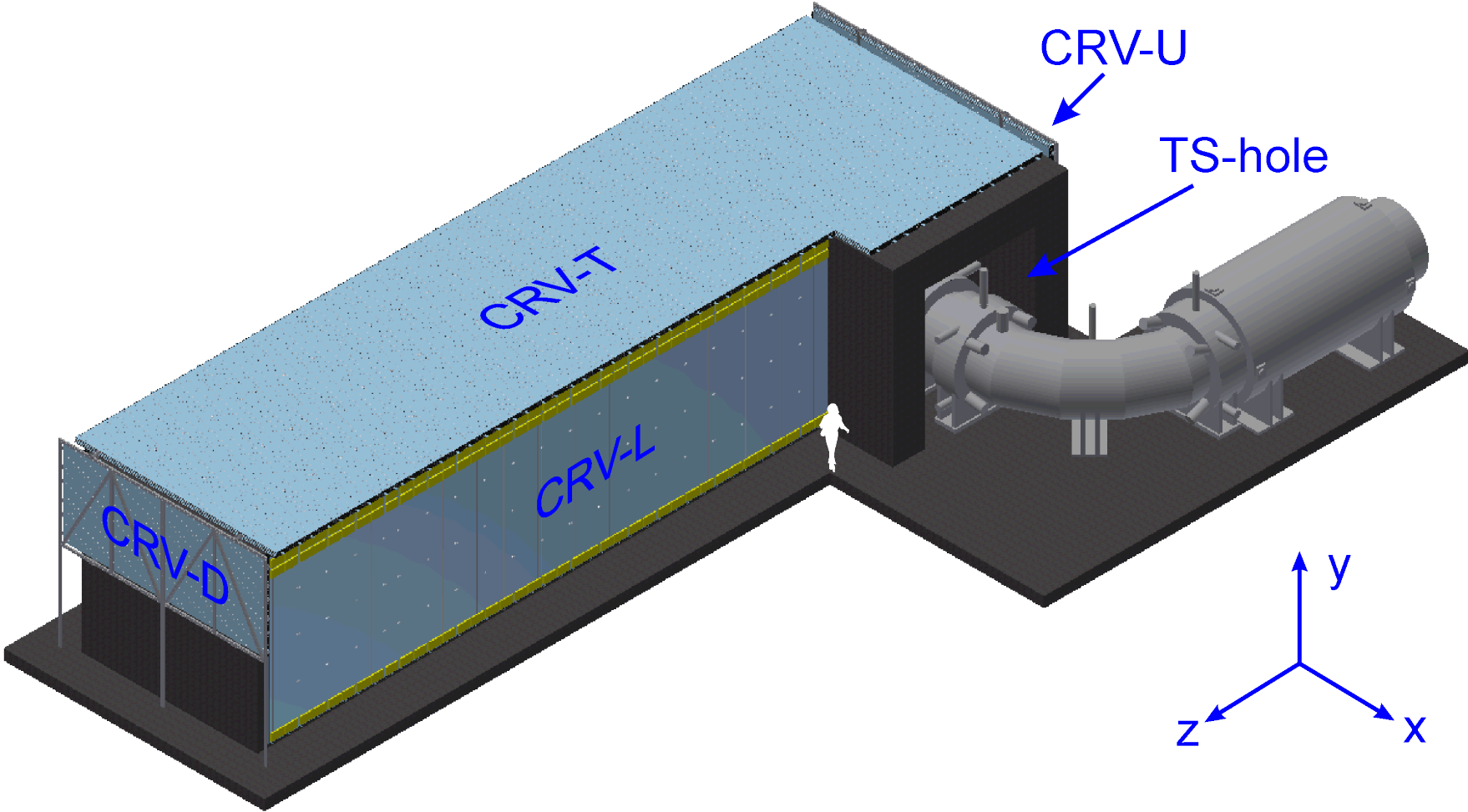

Layout of the CRV

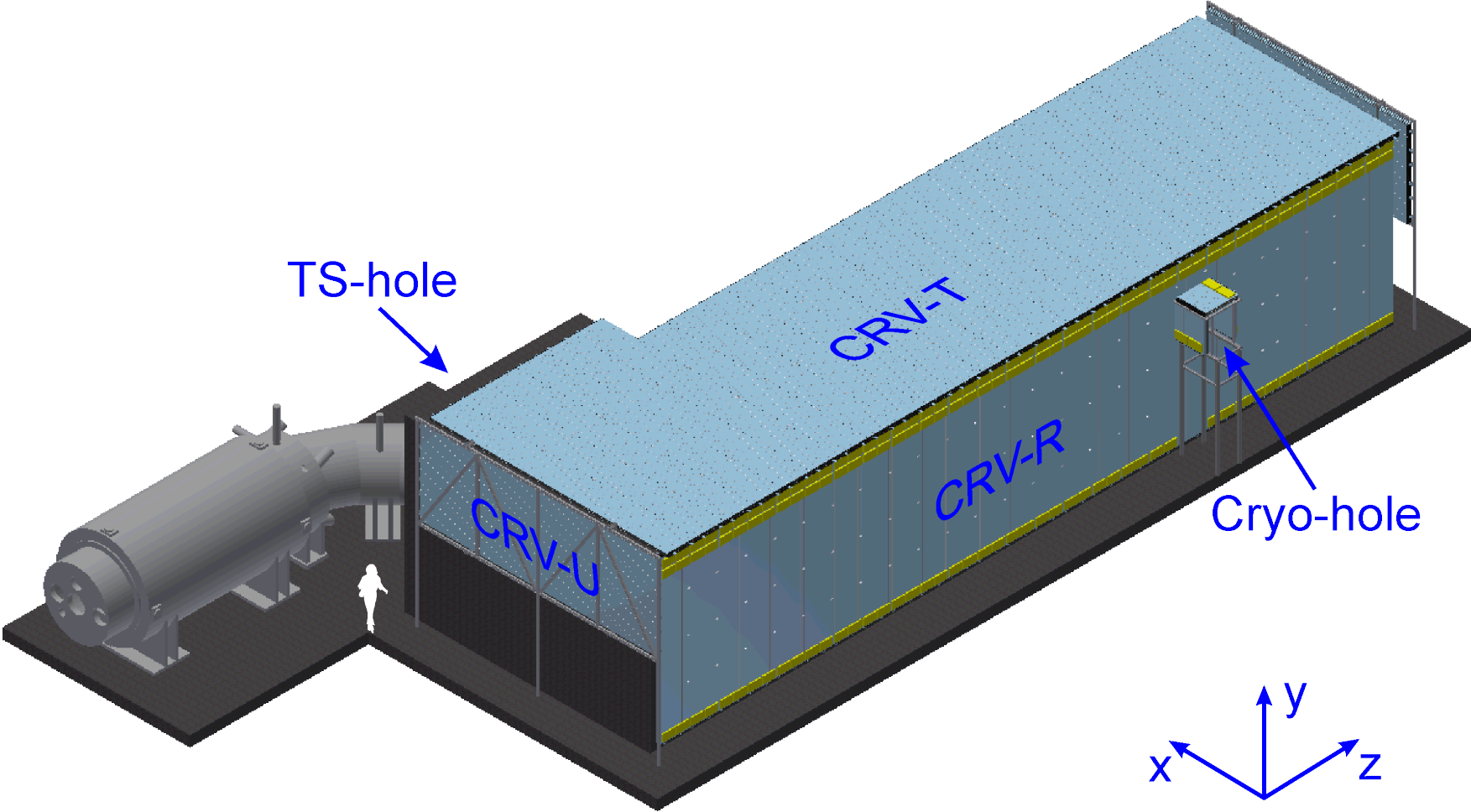

Layout of the CRV

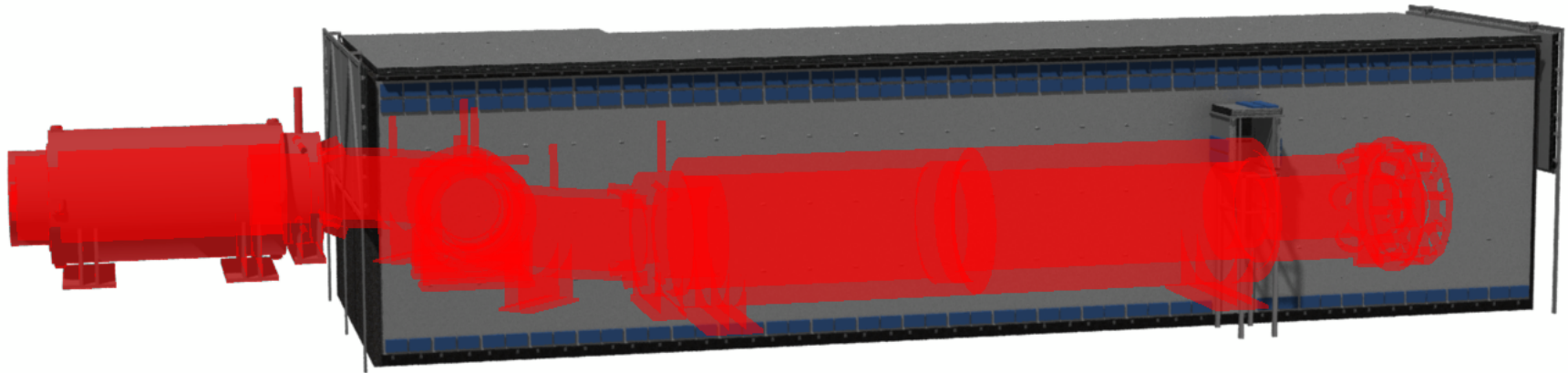

Design: Counter

- Fundamental element of the CRV
- 50 x 20 x 900-6600 mm³
- Extruded at the FNAL-NICADD facility
- Two 1.4-mm diameter wavelength shifting fibers
- Readout: two 2 x 2 mm² SiPMs
- Flasher LED for calibration and monitoring
- Glue two extrusions together to form di-counters that are served by one counter motherboard

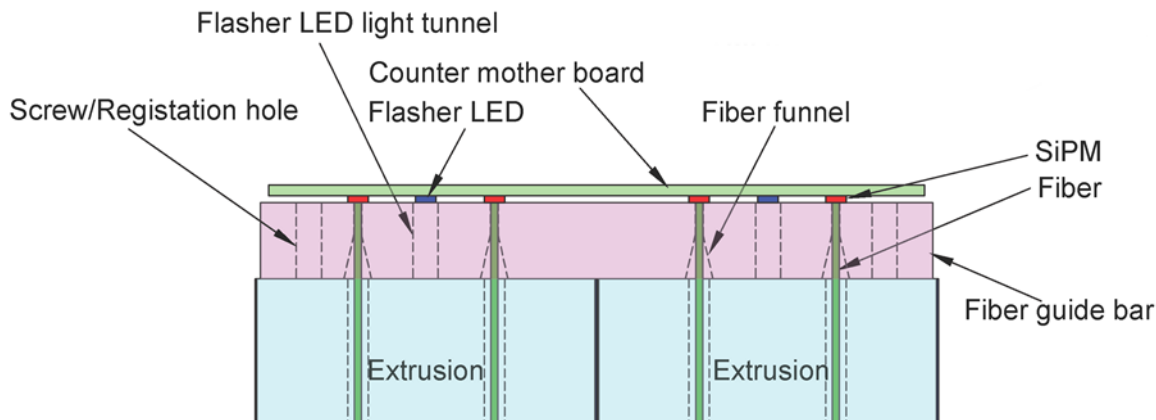
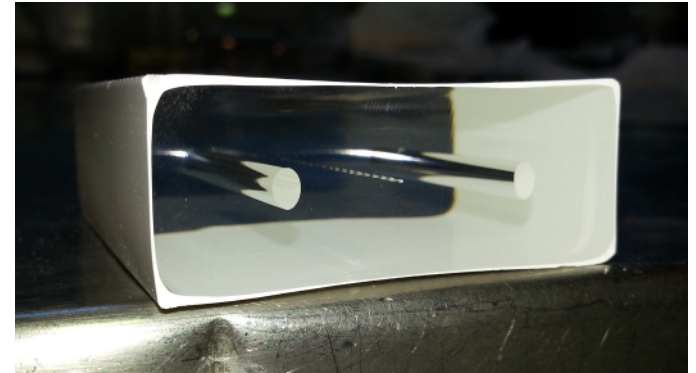

Design: Counter Reflector

- Needed for far side of extra-long modules
- Studies at UVA show a simple design will work

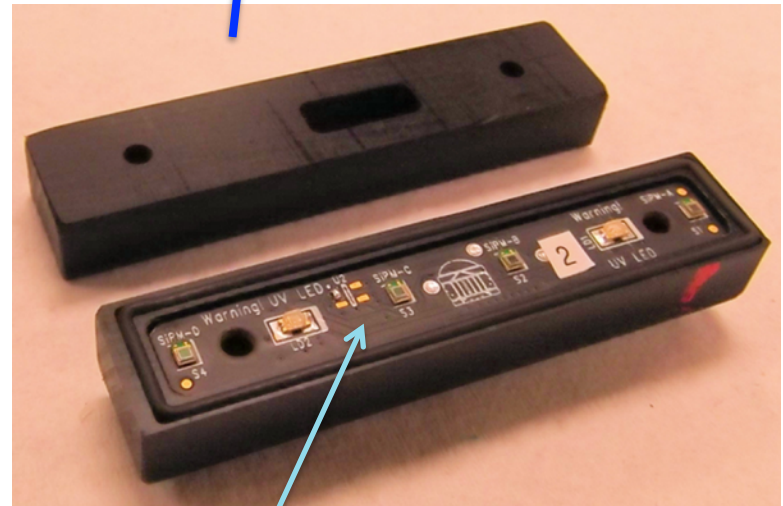
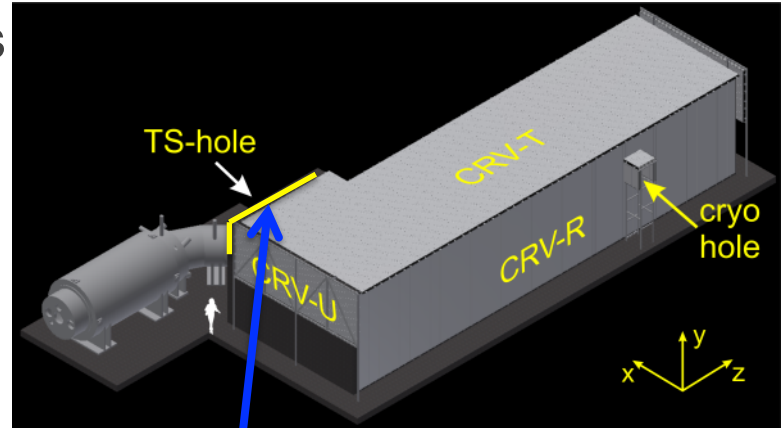
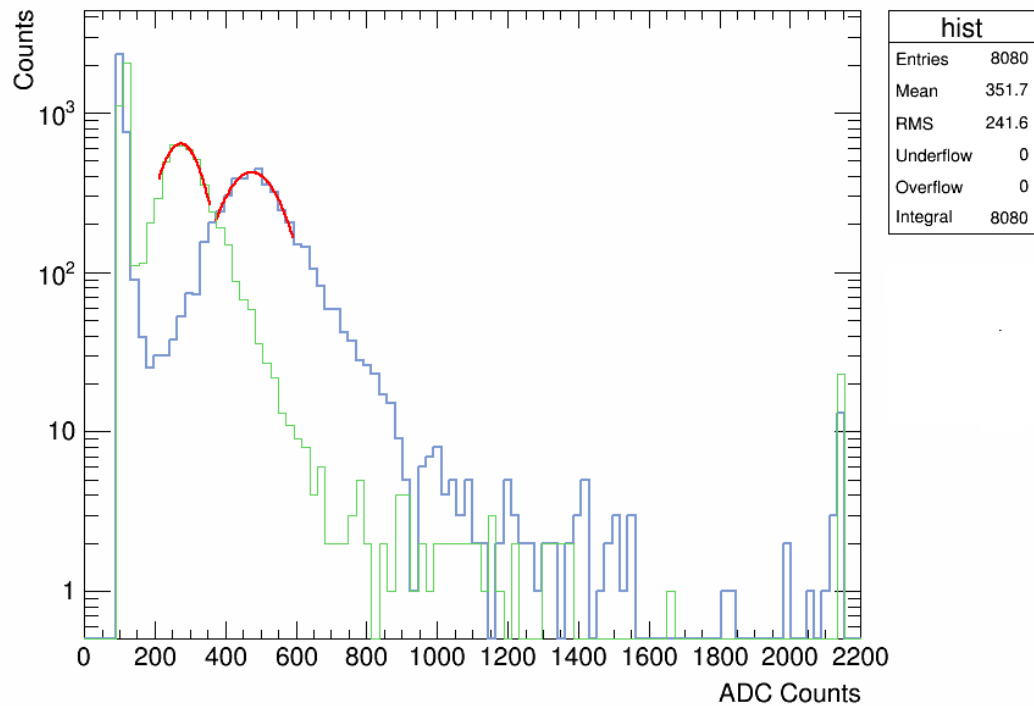

Replace counter motherboard with Al-coated Mylar

Design: Modules

- Fundamental mechanical element of the CRV
- 4 layers of counters: $4 \times 16 = 64$ (narrow: $4 \times 8 = 32$)
- 12.7 mm center Al absorber, 9.5 mm outer Al absorbers
- Di-counters glued to Al absorbers
- Layers are offset to avoid projective gaps between counters
- Total: 82; with two different widths; five different lengths

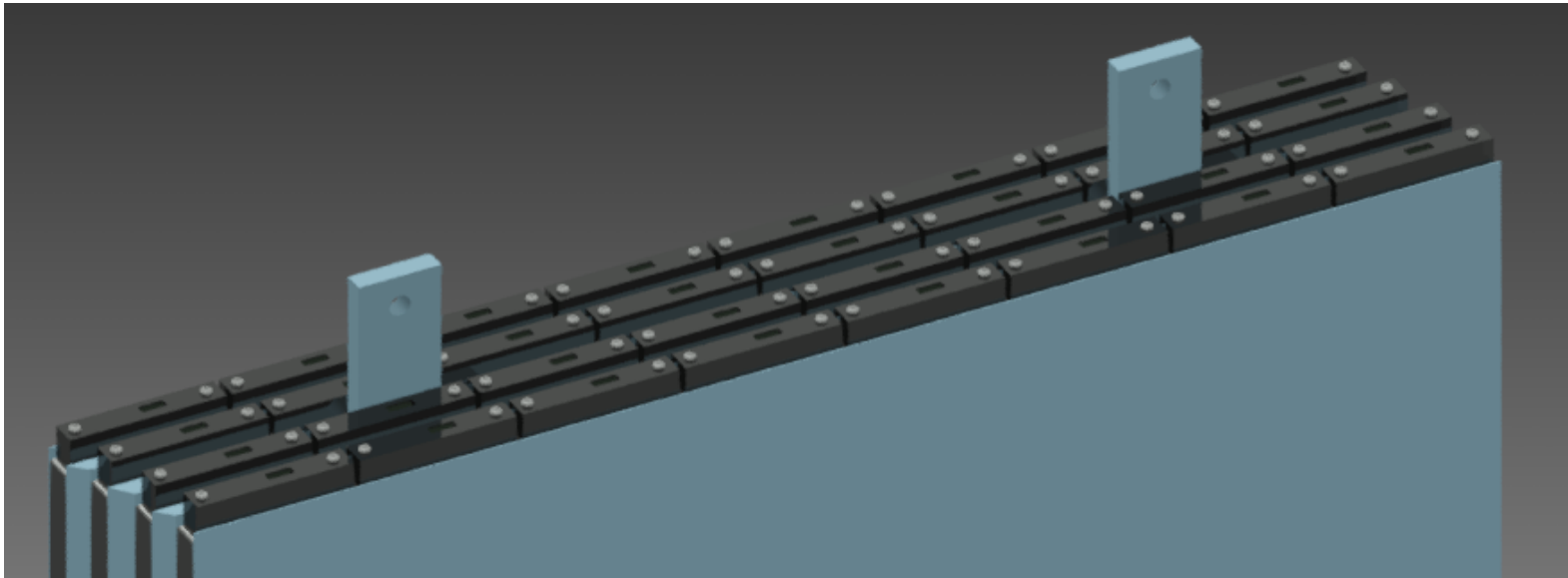

Module Nomenclature

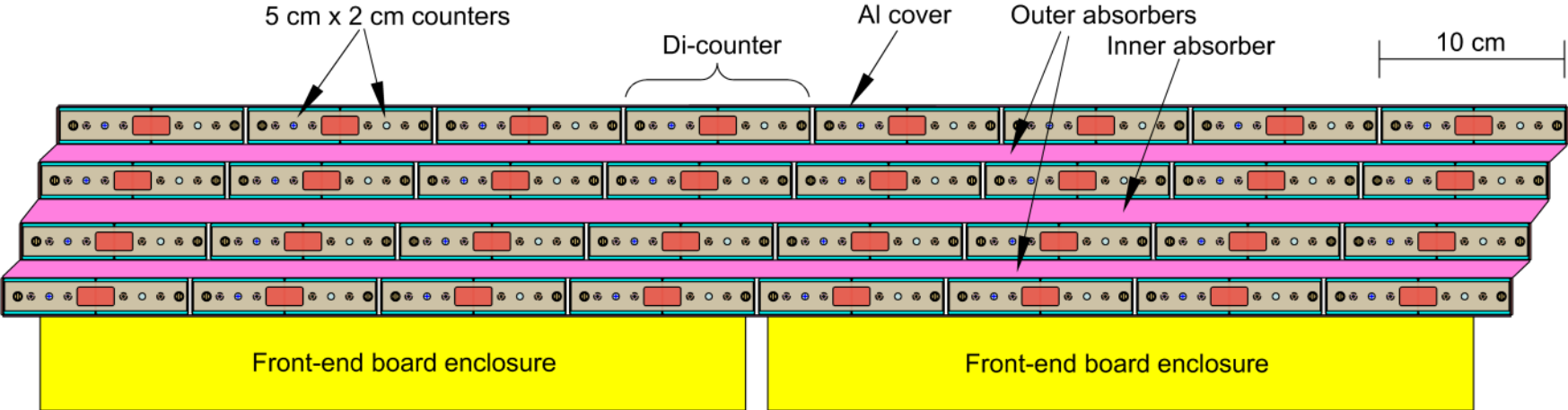
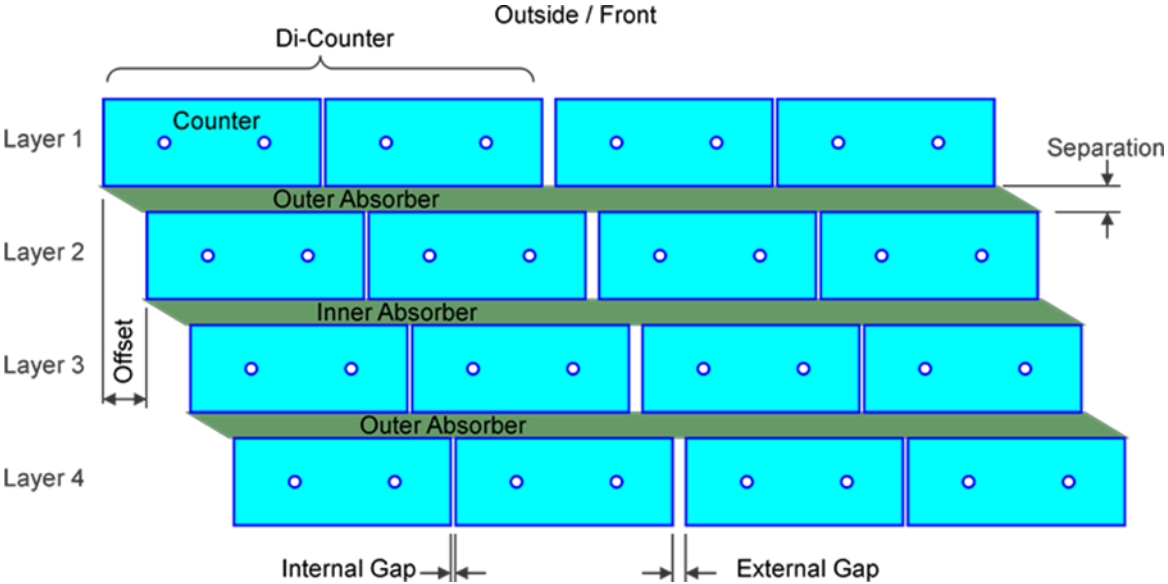

Module Parameters

	Extra-Long	Long	Long-Narrow	Medium	Medium-Narrow	Short	Cryo
Layers				4			
Counter length (m)	6.600	5.600	5.600	4.500	4.500	3.000	0.900
Counter width (m)				0.050			
Counter thickness (m)				0.020			
Overall modules width (m)	0.859	0.859	0.443	0.859	0.443	0.859	0.859
Module external thickness (m)				0.120			
Surface area layer (m ²)	5.471	4.642	2.313	3.731	1.859	2.487	0.746
Inner gap (mm)				1.0			
Outer gap (mm)				3.0			
Layer offset (mm)				10.0			
Fibers/counter				2			
Fiber diameter (mm)				1.40			
Counters/layer	16	16	8	16	8	16	16
Counters total	64	64	32	64	32	64	64
Di-counters total	32	32	16	32	16	32	32
Outer absorber thickness (mm)				9.525			
Inner absorber thickness (mm)				12.700			
Cover thickness (mm)				0.762			
Total module mass (kg)	939	797	398	640	320	427	128
Number of fibers	128	128	64	128	64	128	128
Light yield (far/near)	0.273	0.311	0.311	0.362	0.362	0.454	0.655
Light transit time (ns)	38	32	32	26	26	17	5
Fibers/SiPM				1			
Fiber ends read out	1	2	2	2	2	2	1
SiPMs/module	128	256	128	256	128	256	128
SiPMs per counter mother board	4	4	4	4	4	4	4
Counter mother boards	32	64	32	64	32	64	32
SiPM mounting blocks	32	64	32	64	32	64	32
Counter reflectors	32	0	0	0	0	0	32
Channels per front-end board				64			
Front-end boards	2	4	2	4	2	4	2

Layout: Plan View

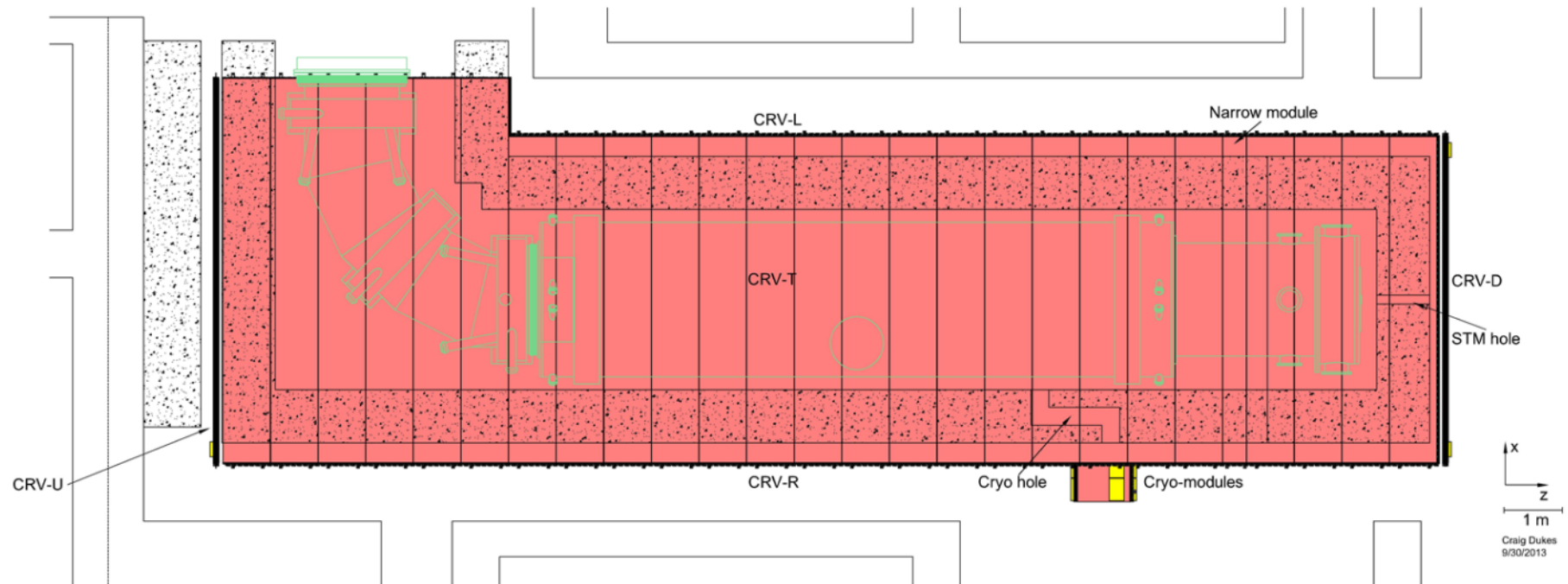

Layout: Crane Access

- Hampered by limited crane coverage and tight space
- Modules will be shipped several to a crate lying flat
- Vacuum lifters used to move them: weigh 2100 lbs to 300 lbs

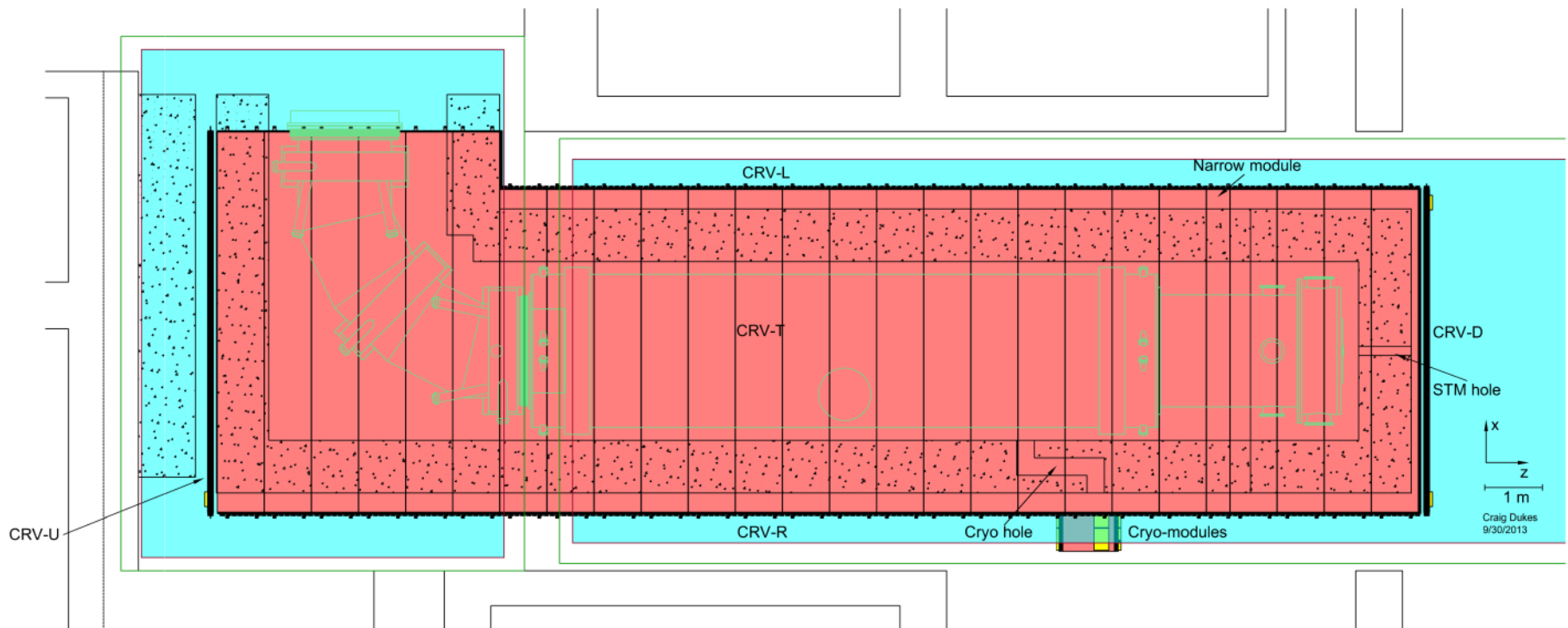

Layout: Right Side Elevation View

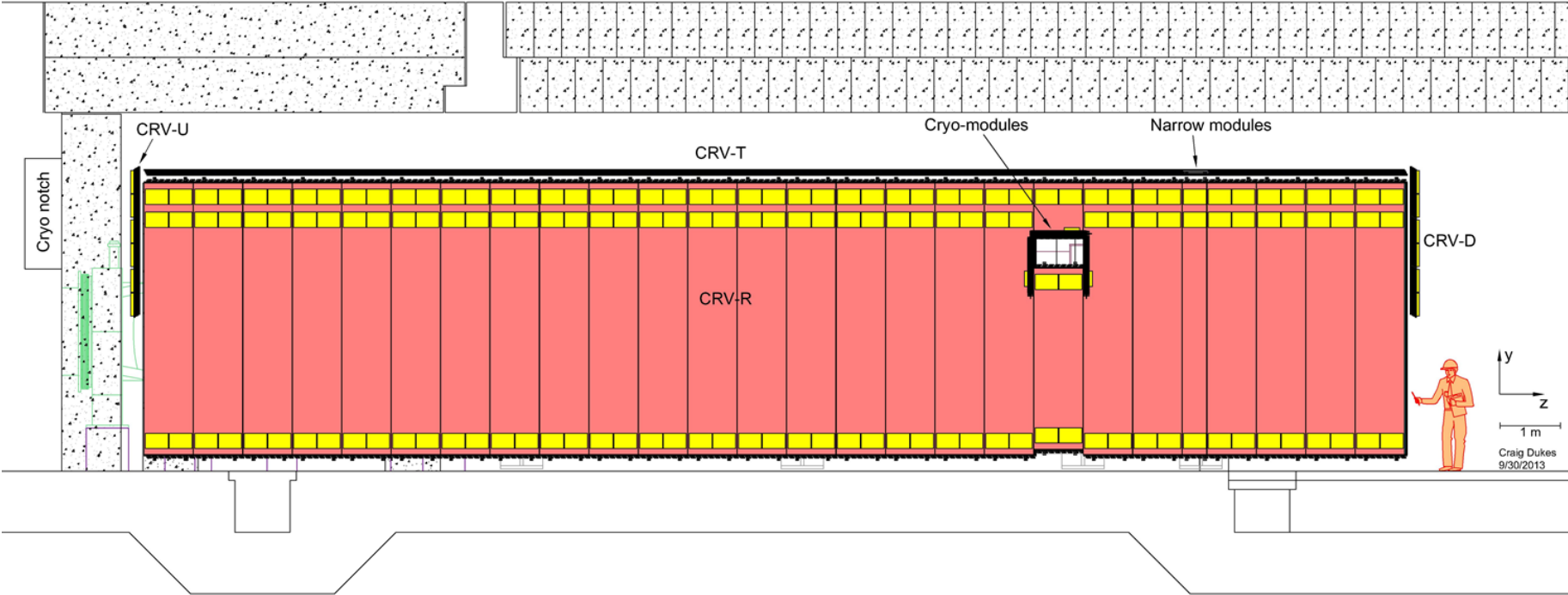

Layout: Upstream Elevation

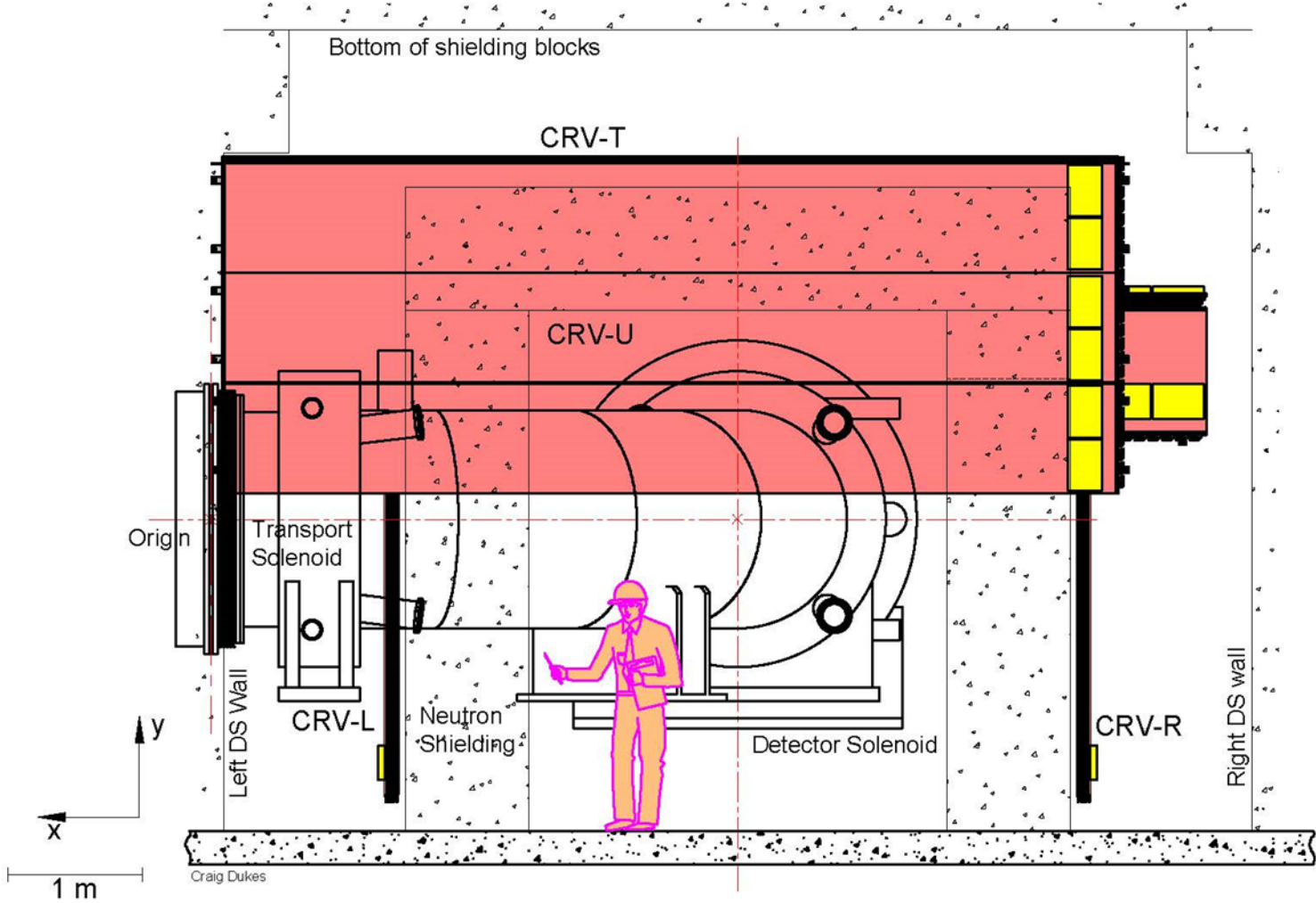

Layout: Downstream Elevation

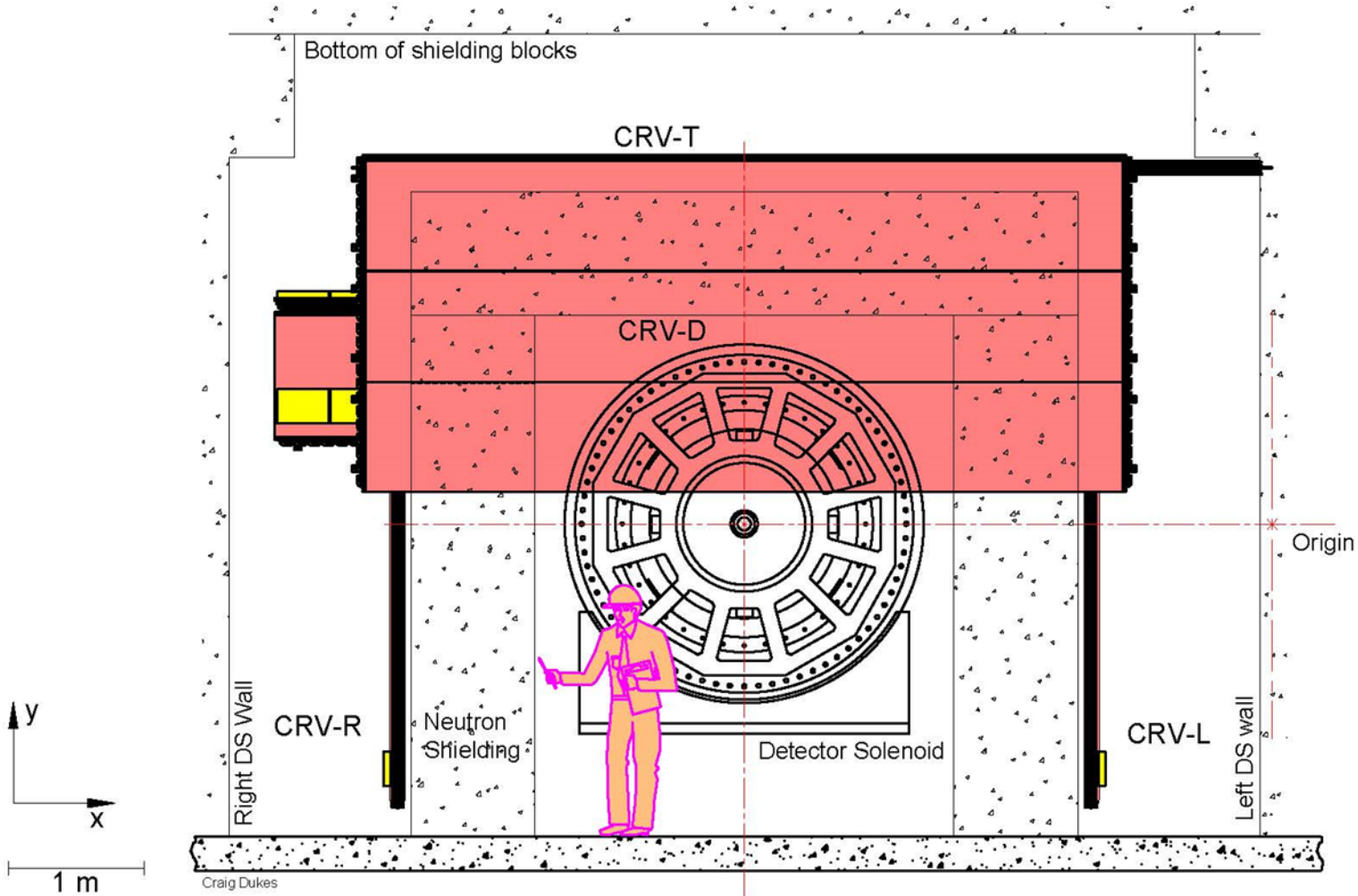

Module Endcaps: CRV-U and CRV-D

- Strongback design to mount them horizontally to allow access to electronics for CRV-U

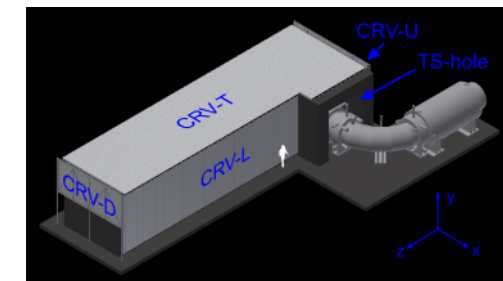
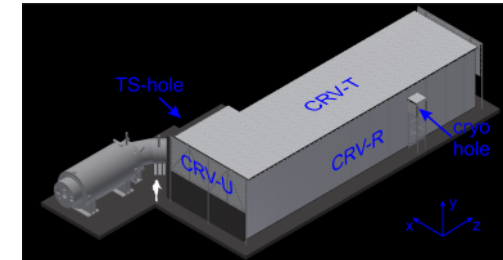
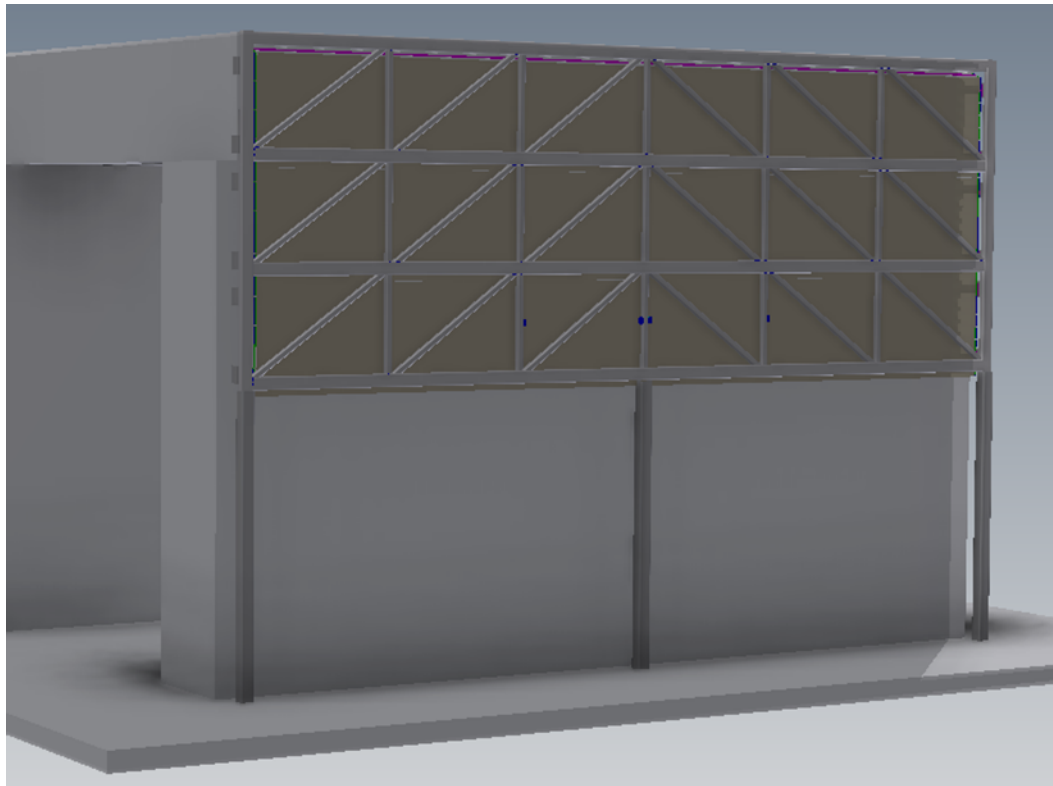

No readout on this end

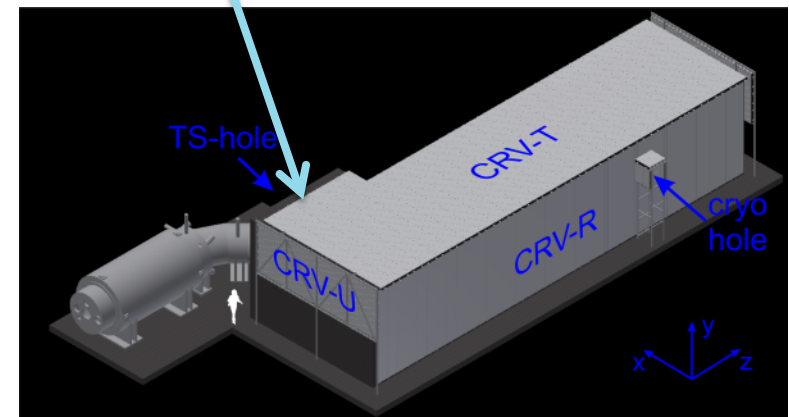

Glue Tests

- Tests recommended by Engineer Guarino done at Virginia
- Devcon HP250 epoxy, 6061 T-6 Al plate scuffed with Scotch-brite
- Shear tests indicate a safety factor of ~600
- Peel tests underway

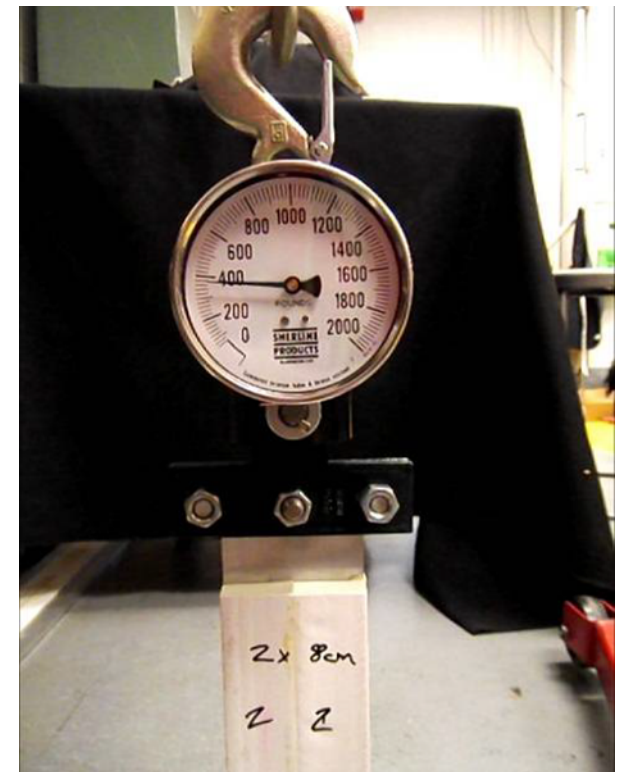
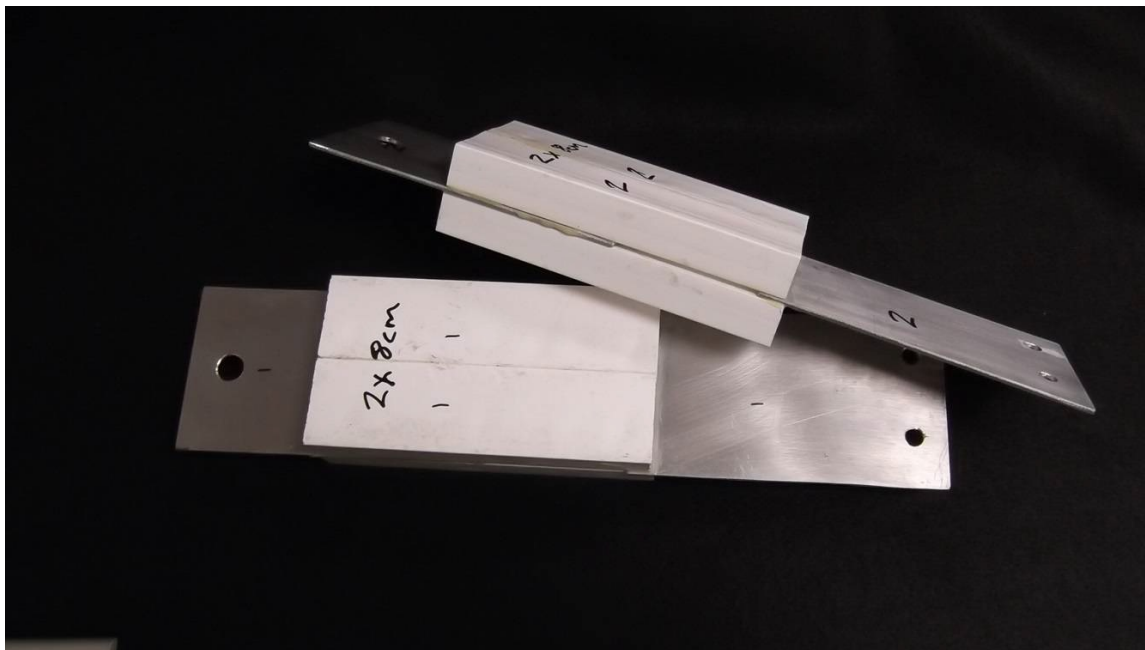

Mechanical Design: Support Structure

- Designed to minimize gaps between modules, allow the modules to be installed and removed without undue difficulty, and allow access to electronics
- Hangers that bolt onto the tabs for the side modules
- Use adjustable draw latches attached to front Al sheets to mate modules together
- TDR design with C-channels on top with ball rollers to support the top modules recently replaced with Teflon strips per recommendation in CRV-Review

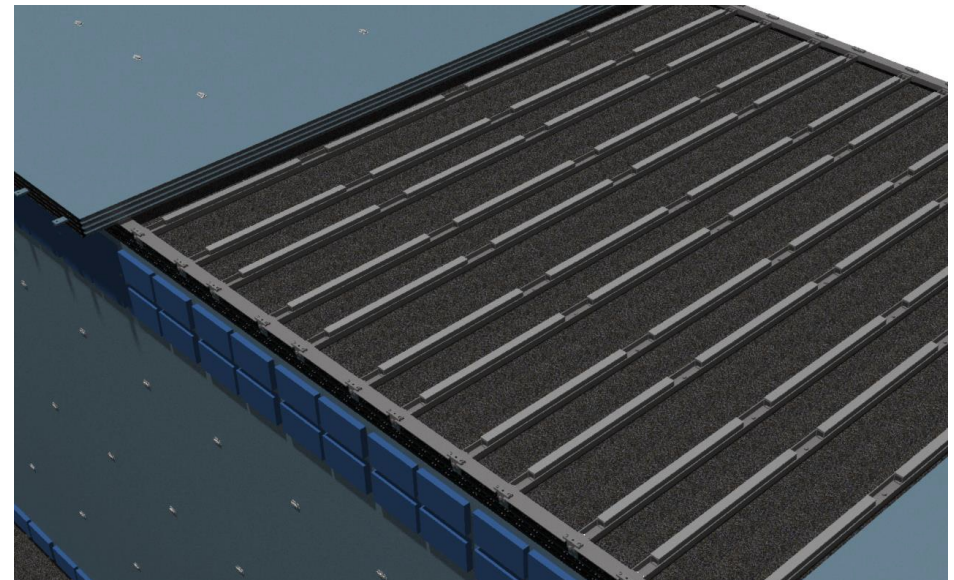
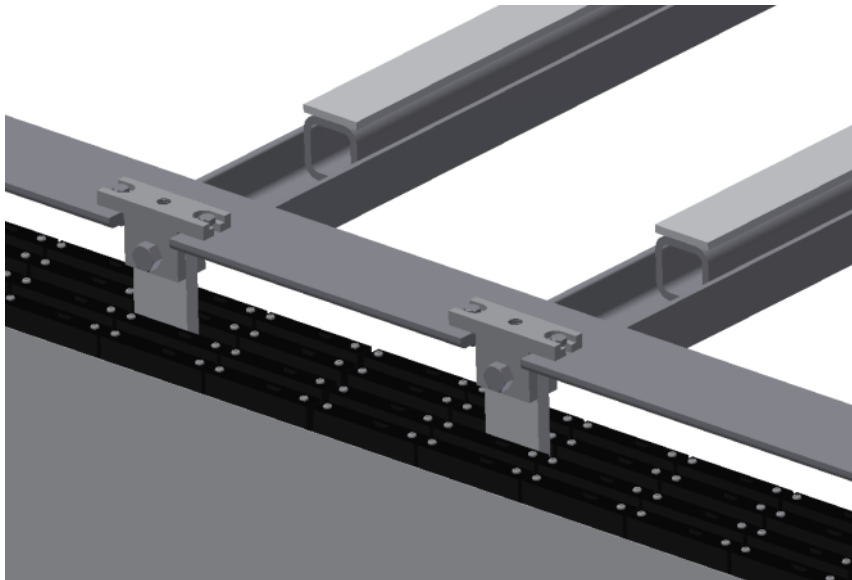

Mechanical Design: Support Structure

Structural studies have been made.

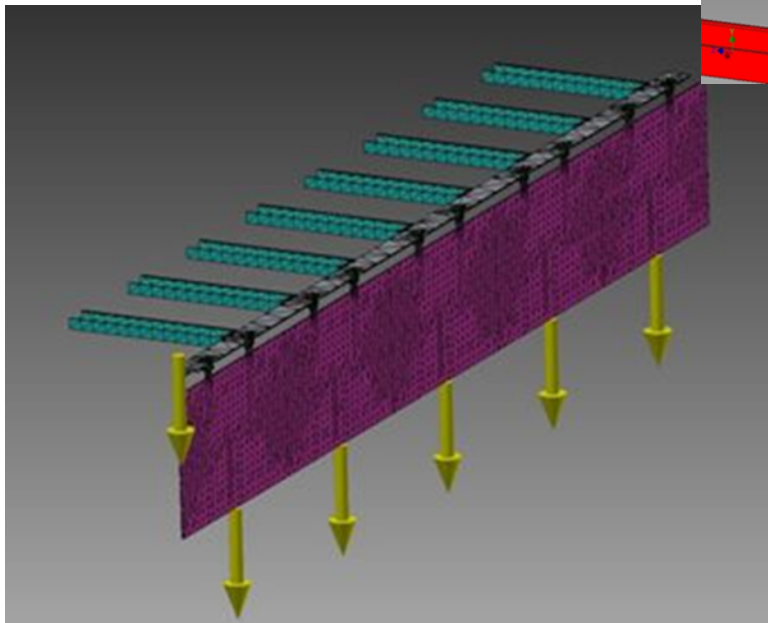
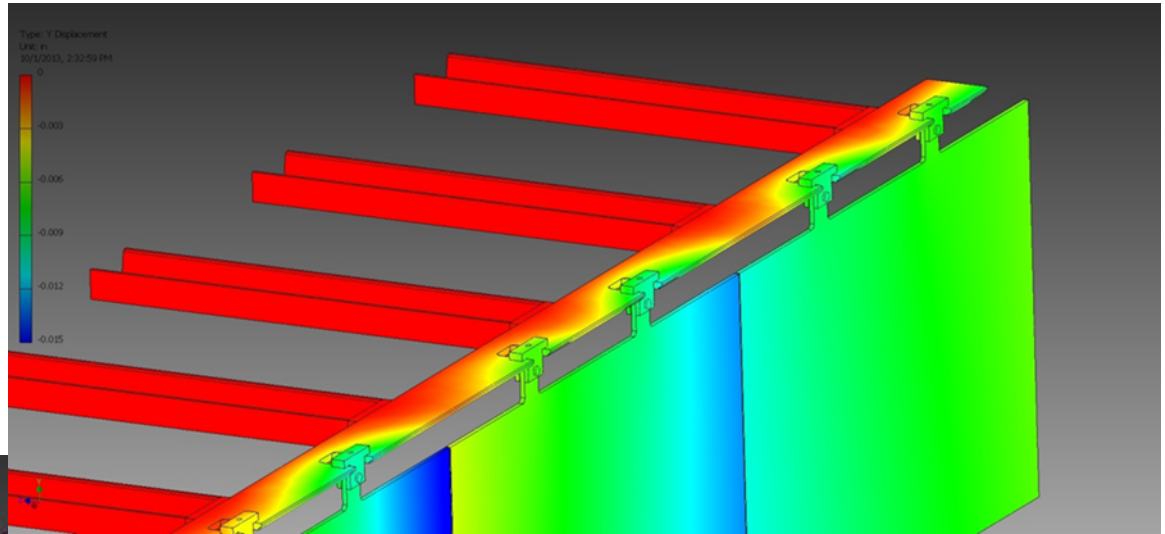

Mu2e

Cosmic Ray Veto Parameters

	Sector					Total
	CRV-U	CRV-T	CRV-L	CRV-R	CRV-D	
Extra-Long	3	6	0	0	0	9
Long	0	19	0	0	3	22
Long-Narrow	0	1	0	0	0	1
Medium	0	0	19	24	0	43
Medium-Narrow	0	0	1	1	0	2
Short	0	0	0	1	0	1
Cryo	0	0	0	4	0	4
Total	3	26	20	30	3	82
Sector active area (m ²)	16	123	73	97	14	323
Scintillator active area (m ²)	63	476	281	374	54	1,248
Counters	192	1,632	1,248	1,888	192	5,152
Di-counters	96	816	624	944	96	2,576
Extrusions per layer	48	408	312	472	48	1,288
Extrusion length (m)	1,267	9,523	5,616	7,478	1,075	24,960
Scintillator mass (kg)	1,343	10,095	5,953	7,927	1,140	26,458
Total sector mass (kg)	2,818	21,176	12,488	16,202	2,391	55,075
Fibers	384	3,264	2,496	3,776	384	10,304
Fiber length (m)	2,544	19,129	11,295	15,053	2,160	50,182
SiPMs	384	5,760	4,992	7,040	768	18,944
Fiber guide bars	192	1,632	1,248	1,888	192	5,152
Counter reflector manifolds	96	192	0	128	0	416
Counter mother boards	96	1,440	1,248	1,760	192	4,736
SiPM mounting blocks	96	1,440	1,248	1,760	192	4,736
Front-end boards (FEB)	6	90	78	110	12	296
Readout channels	384	5,760	4,992	7,040	768	18,944
FEBs per readout controller			24			
Readout controllers	1	4	4	5	1	15

Simulations: Conversion Background

Simulations: Conversion Background

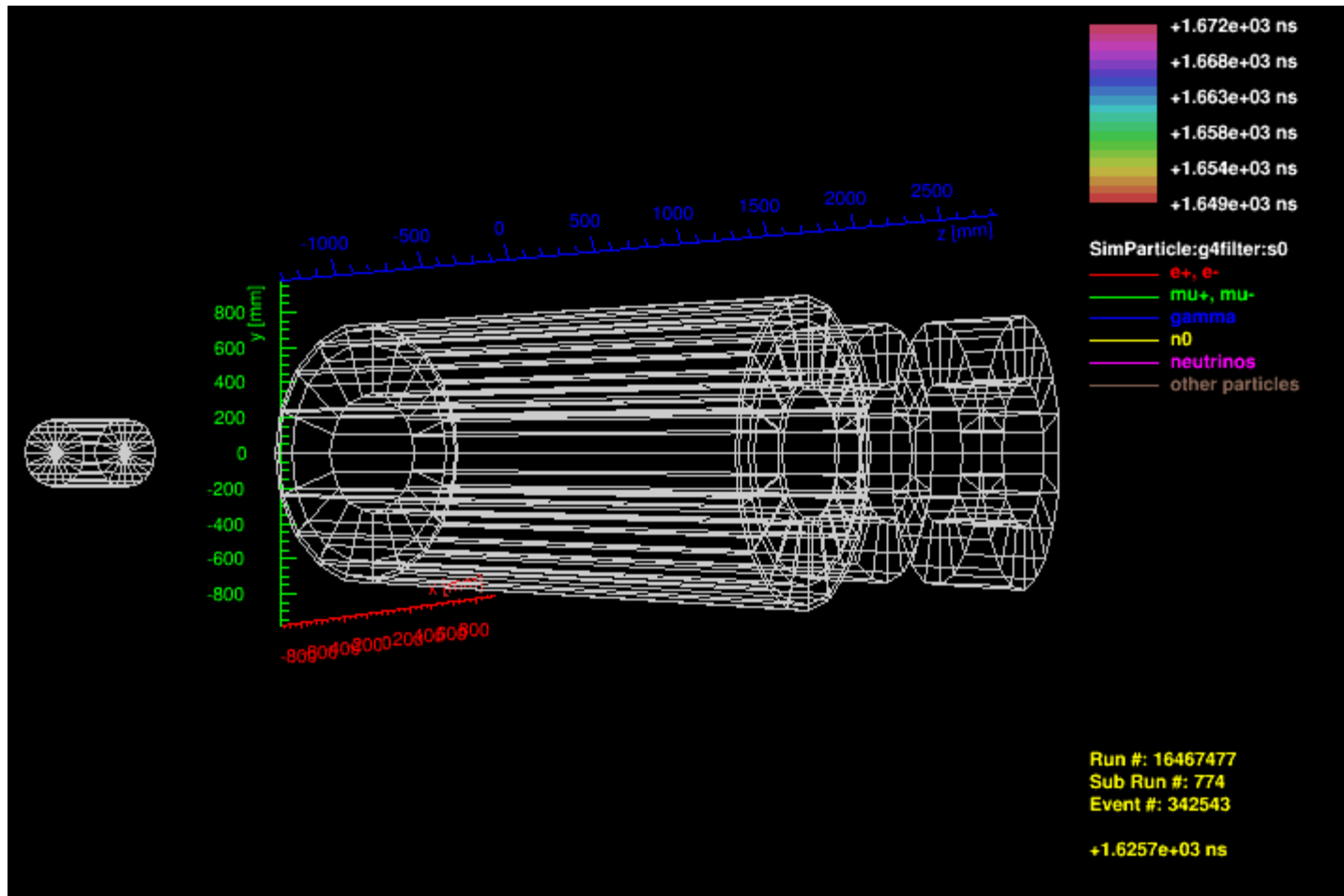

Simulations: Conversion Background

- Code extensively rewritten to speed up simulation by staging it
- Goal was to simulate the entire running period for “critical” regions: CRV-U, CRV-D, TS hole

Background Processes

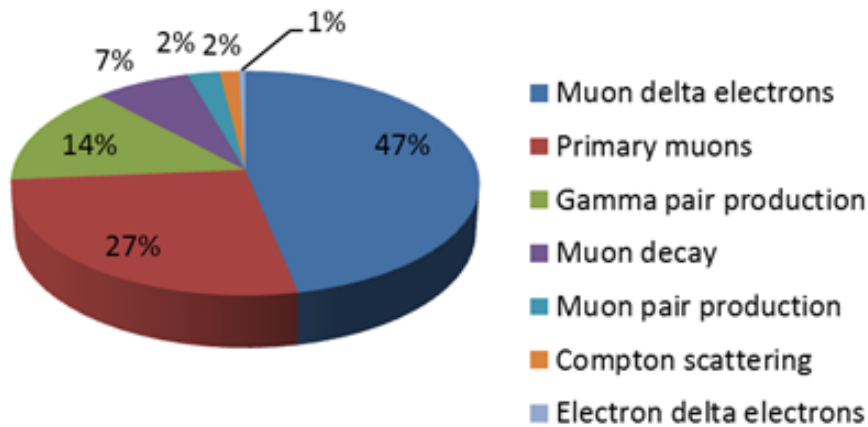

Background Sources

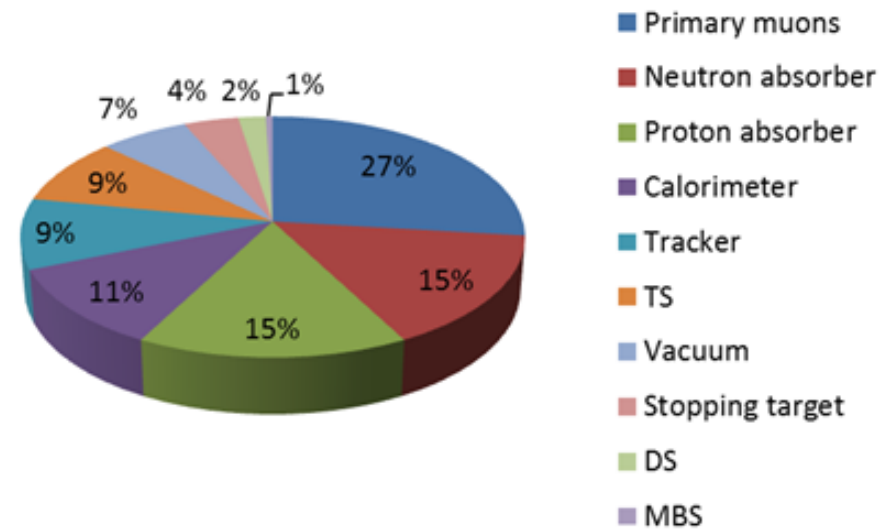

Note: a good track stub causes a 125 ns veto window in the offline analysis

Simulations: Sources of Background Events

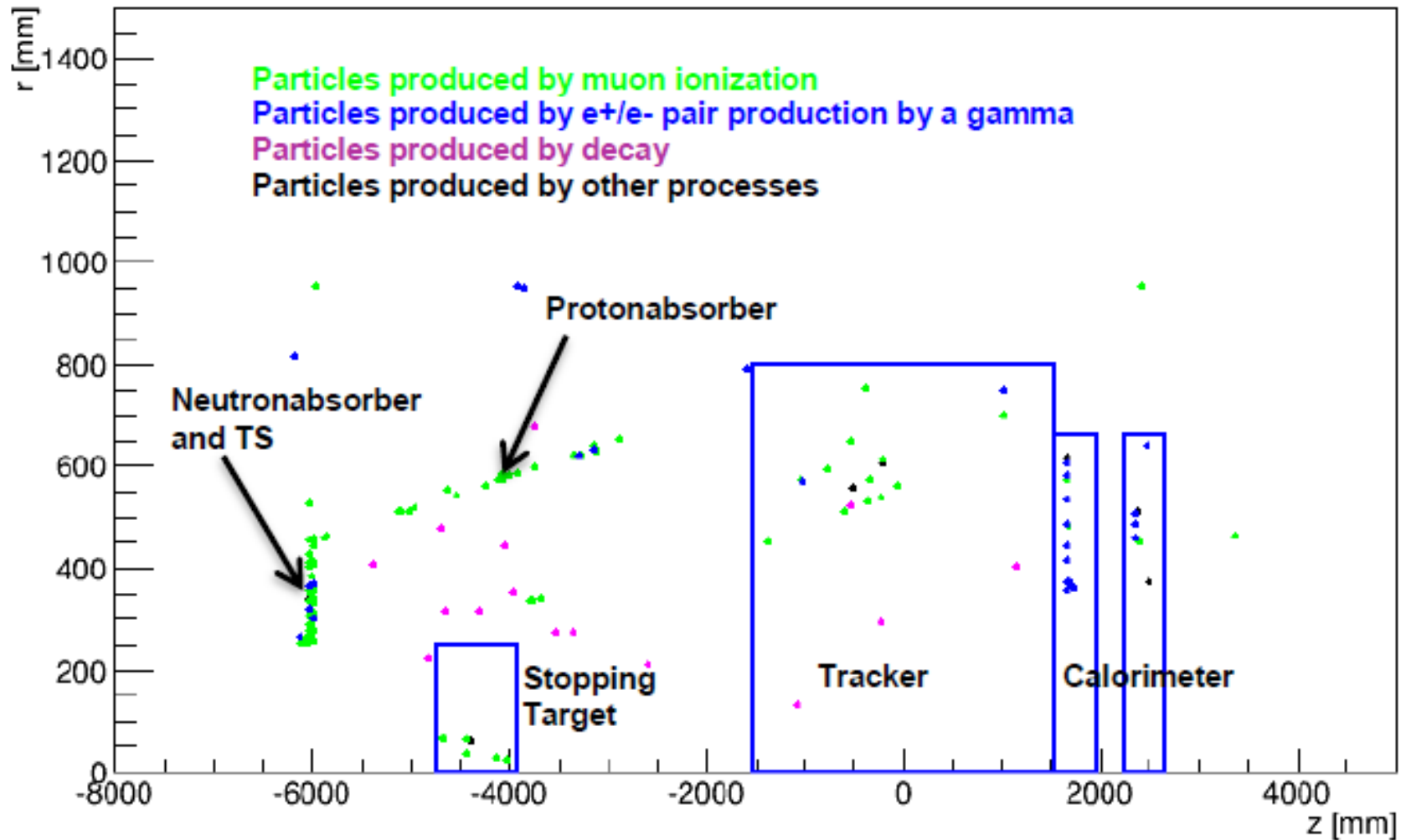

Simulations: Conversion Background

- Generated 27.9 billion cosmic-ray muons in a global simulation of the entire CRV, and 126.2 billion in three targeted regions: TS-hole, CRV-U, and CRV-D.
- All conversion-like background events in the global simulation hit the CRV and would be vetoed given sufficient efficiency: $1 - 1 \times 10^{-4}$.
- A scaled total of 0.8 muons make it through the TS-hole and are reconstructed as electrons, but are vetoed by tracker/calorimeter particle ID cuts.
- A scaled total of 0.4 muons make it below the CRV-D coverage and are reconstructed as electrons, but are vetoed by tracker/calorimeter particle ID cuts.

Global Simulation		
	CDR	TDR
MC Muons	1.1×10^9	27.9×10^9
% Total Live Time	0.2%	2.0%
Background Events	14 ± 4	159 ± 13

Targetted TS Region Simulation		
Region	% Total Live Time	
	CDR	TDR
TS hole	0%	93%
CRV-U	0%	95%
CRV-D	0%	103%

Simulations: Conversion Background

Total number of incident muons:	$93.5 \times 10^3 \mu/s \cdot 1.48 \times 10^7$ live seconds
Simulated events energy window:	10 MeV
Signal energy window:	1.25 MeV
# of generated events:	27.9×10^9 events
# of accepted events:	159 ± 13
90% CL # of accepted events:	176
Max. # of background events:	0.10

$$93.5 \times 10^3 \mu/s \cdot 1.48 \times 10^7 s \cdot 0.955 \cdot \frac{1.25 \text{ MeV}}{10 \text{ MeV}} \cdot \frac{176 \text{ evts}}{27.9 \times 10^9 \mu} = 1042 \text{ evts}$$

$$\bar{e} = \frac{0.10}{1042} = 0.96 \times 10^{-4}$$

Simulations: Coverage – CRV-T

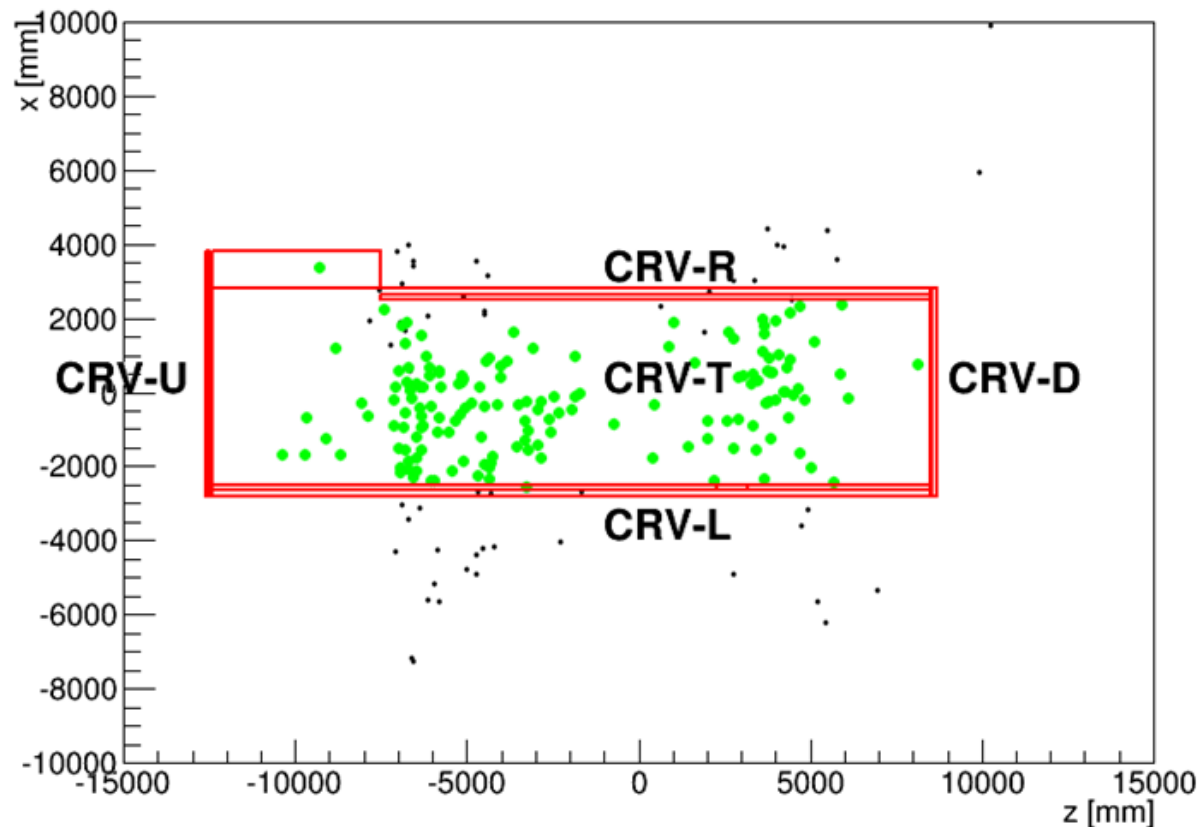

The xz points of impact at the plane of the CRV-T sector for those cosmic-ray muons that produce conversion-like background events. Green markers indicate muons that only impact the CRV-T plane and none other.

Simulations: Coverage – CRV-L

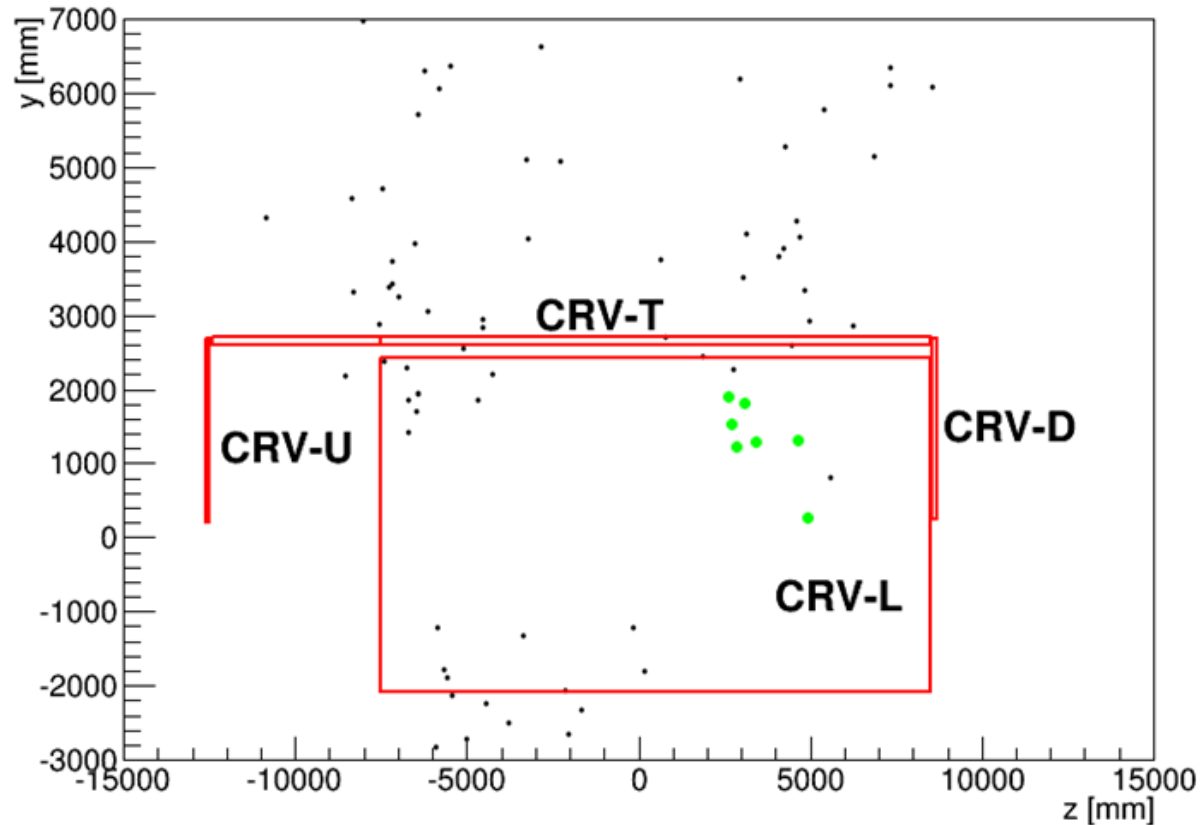

The yz points of impact at the plane of the CRV-L sector for those cosmic-ray muons that produce conversion-like background events. Green markers indicate muons that only impact the CRV-L plane and none other.

Simulations: Coverage – CRV-R

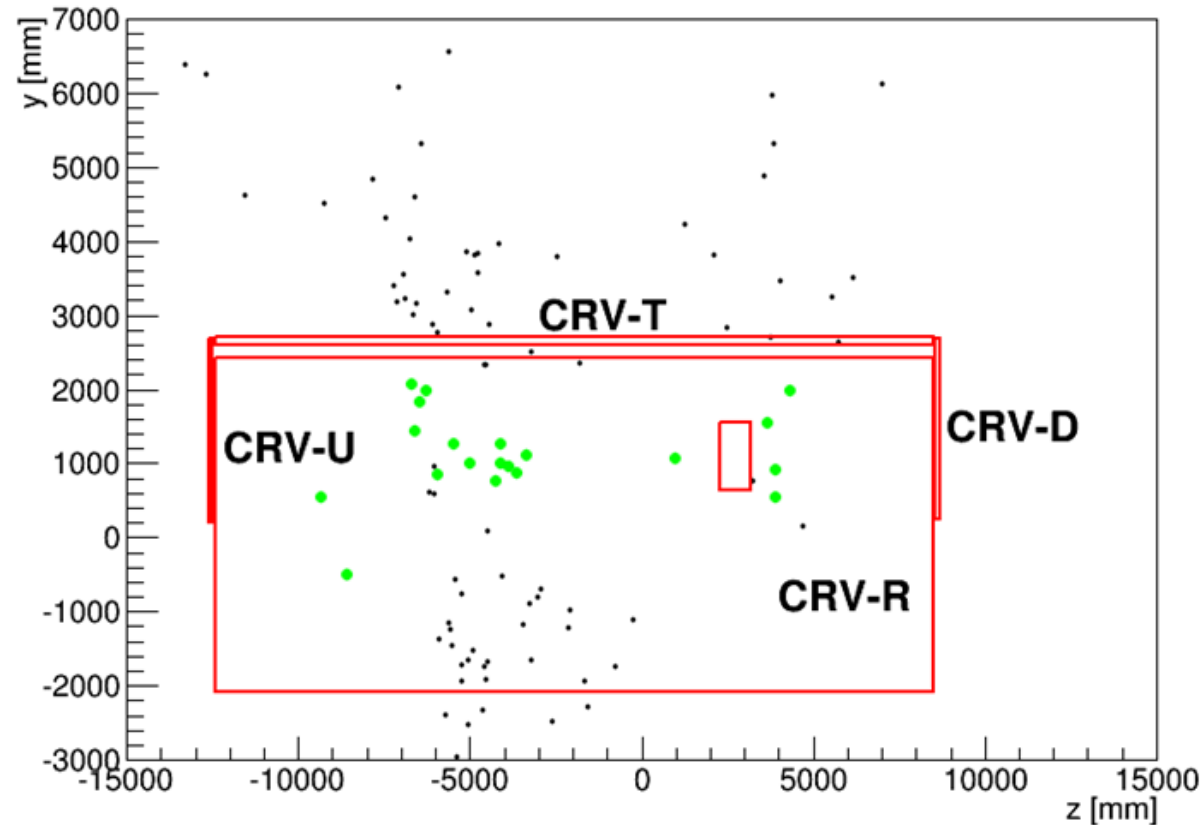

The yz points of impact at the plane of the CRV-R sector for those cosmic-ray muons that produce conversion-like background events. Green markers indicate muons that only impact the CRV-R plane and none other..

Simulations: Coverage – CRV-U

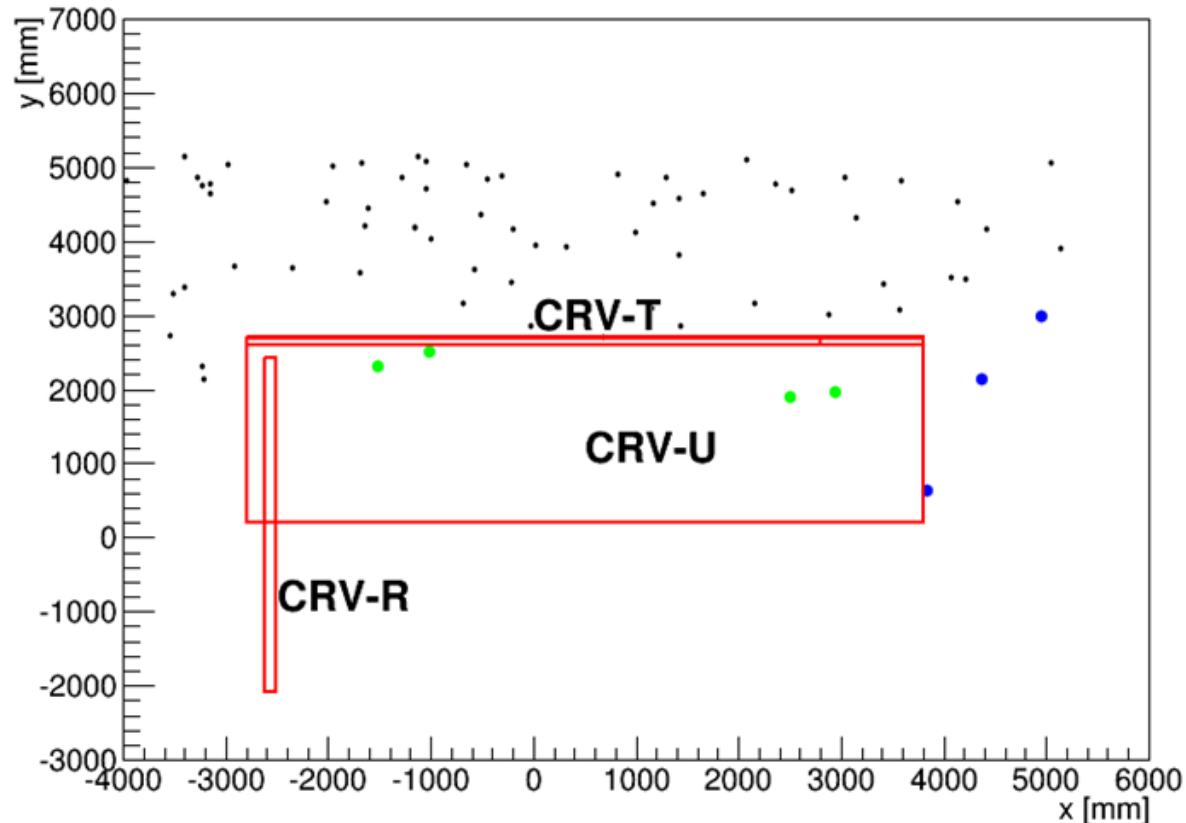

The xy points of impact at the plane of the CRV-U sector for those cosmic-ray muons that produce conversion-like background events. Green markers indicate muons that only impact the CRV-U plane and none other, while blue markers indicate muons that are not vetoed by any part of the CRV (muons that pass track-finding cuts but are vetoed by the calorimeter).

Simulations: Coverage – CRV-D

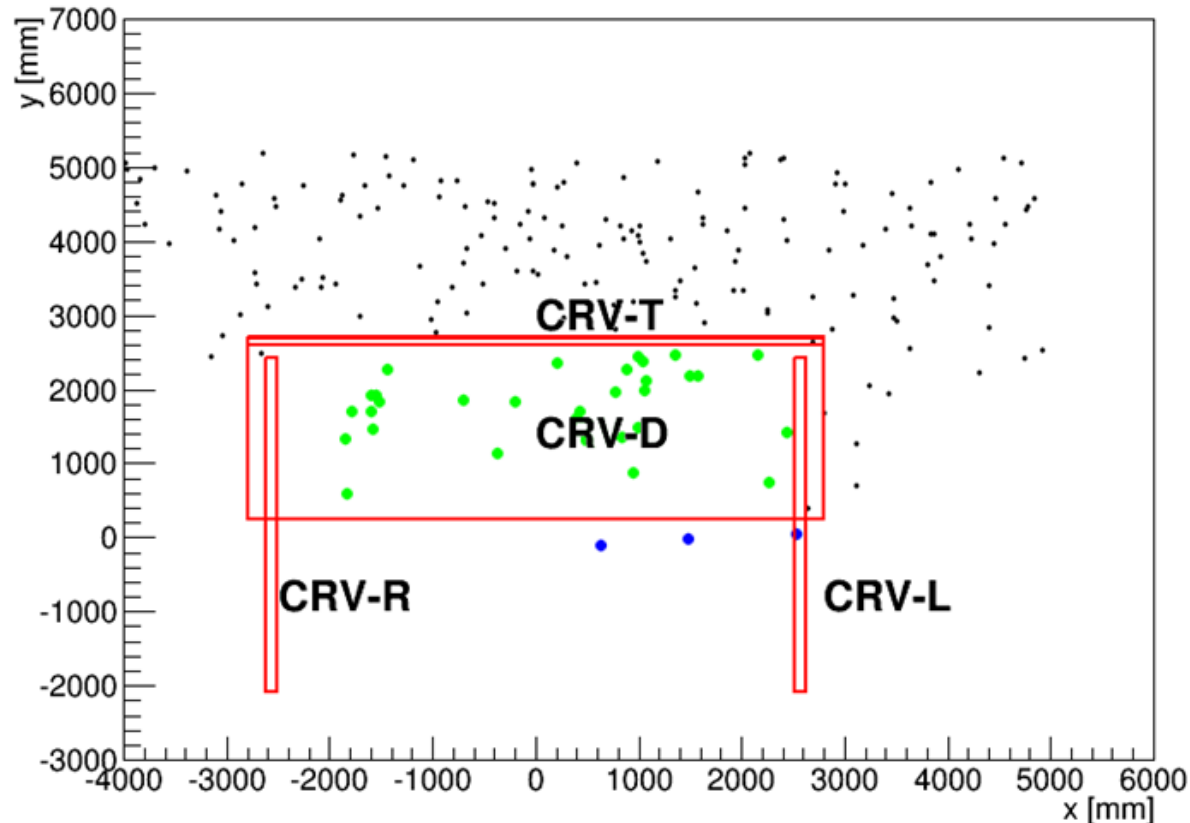

The xy points of impact at the plane of the CRV-D sector for those cosmic-ray muons that produce conversion-like background events. Green markers indicate muons that only impact the CRV-D plane and none other, while blue markers indicate muons that are not vetoed by any part of the CRV (muons that pass track-finding cuts but are vetoed by the calorimeter).

Simulations: Efficiency Requirement

- An inefficiency of 10^{-4} in finding muon track stubs with a 3/4 hit plane requirement demands a 99.5% single-plan efficiency.
- The efficiency of a particular plane depends on the angle the muons make and the size of the gaps between counters.

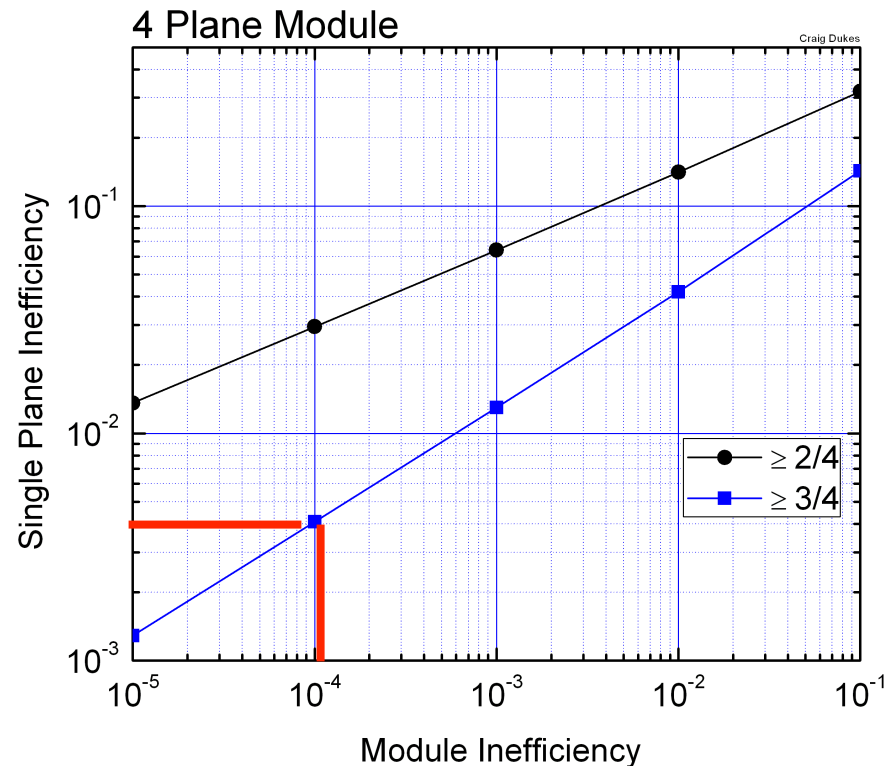

Performance: Efficiency Requirement

The single-plane efficiency requirement of 99.6% can be best couched in terms of a counter photoelectron yield requirement.

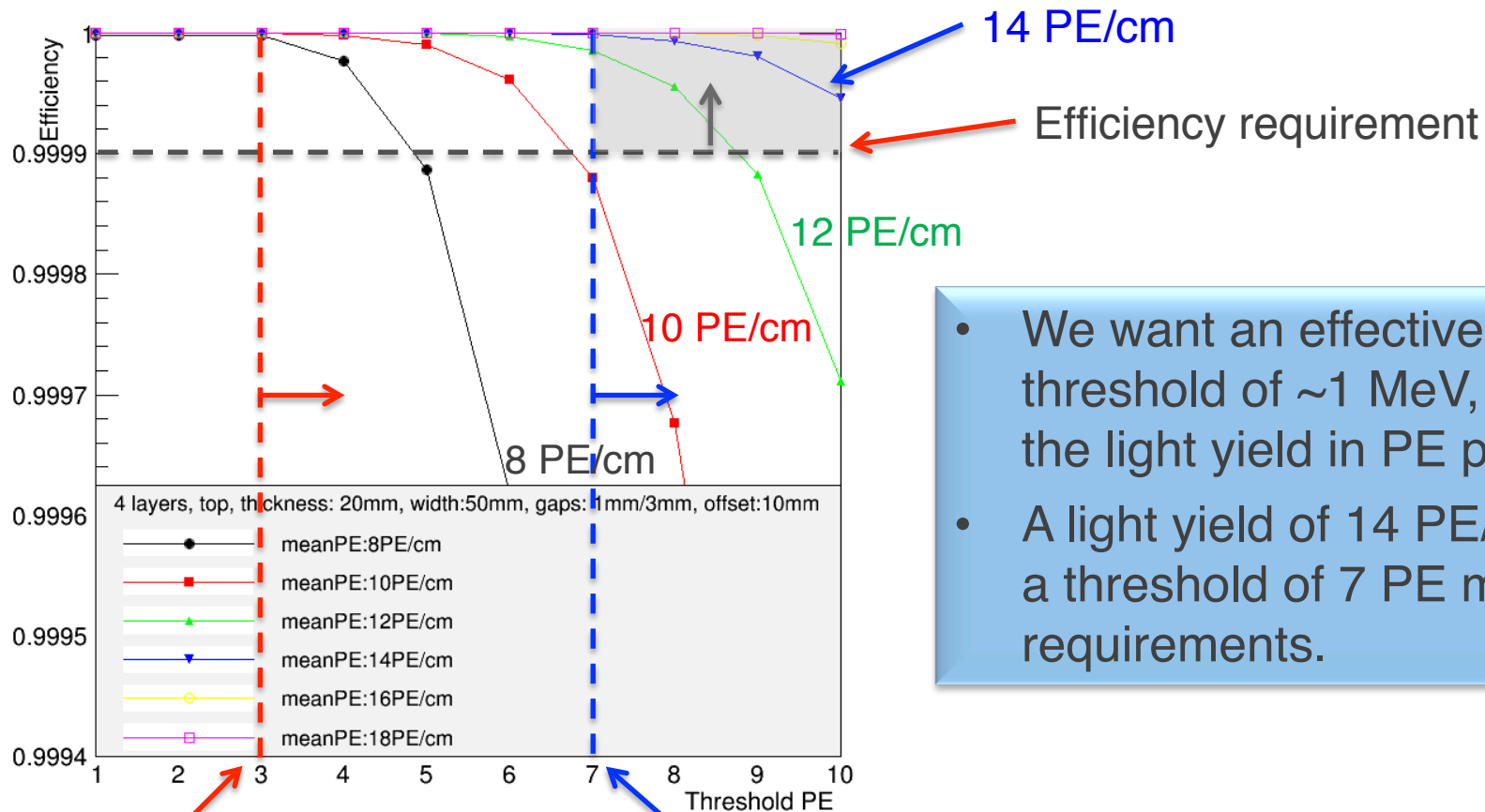

- We want an effective energy threshold of ~ 1 MeV, or half the light yield in PE per cm
- A light yield of 14 PE/cm with a threshold of 7 PE meets requirements.

Individual SiPM noise limit

“Energy” threshold: both SiPMs at each end

Performance: Efficiency Requirement

- Important: the key parameter in meeting the efficiency requirement is the photoelectron yield.
- The means by which we meet the required PE yield is through the wavelength shifting fiber diameter.
- Extrapolations from test-beam data of a pre-prototype counter, and from NOvA measurements of the PE yield vs fiber diameter show that 14 PE/cm at the far end of a long counter can be achieved with a 1.4 mm diameter fiber. We will test modules with 1.4 mm and 1.8 mm fibers next spring in the Fermilab Meson Test Beam Facility and use the results to determine the appropriate diameter.



Photoelectron Yield

CRV Test Beam:

- Measure the PE yield for different orientations.
- Measure glued vs free fibers.
- Measure the effect of cracks between di-counters.
- Measure difference between canned and surface-mount SiPMs.



Two di-counters back-to-back, one with glued fibers, one not.

A 3-layer short module in horizontal position.

Photoelectron Yield

- Measured PE yield of pre-prototype counter in test beam run in October 2013
- Find 31 PE/cm (@ near end): need 48 PE/cm or 1.5 X
- Get increase by going from 1.0 mm to 1.4 mm diameter fiber

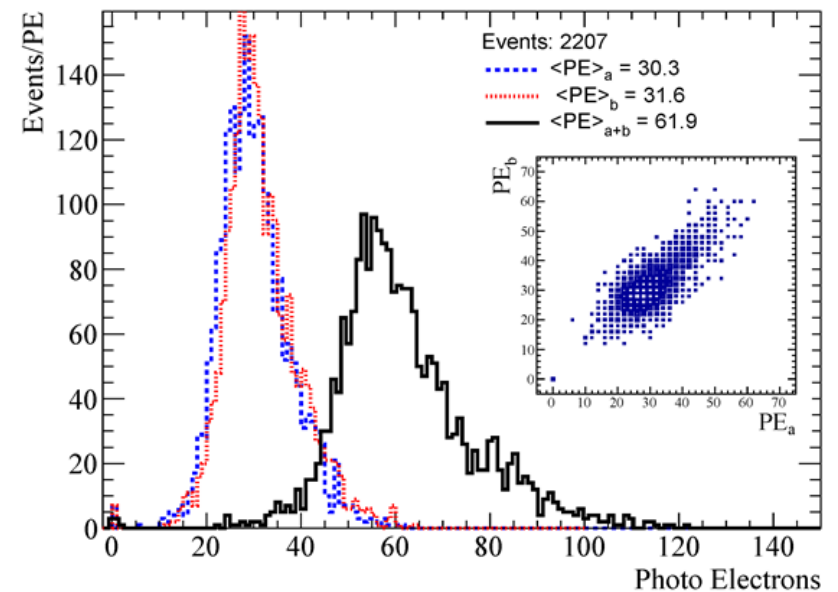

Photoelectron Yields and Thresholds

Module Type	Length	Atten. Factor	Ageing x Atten Factor	Measured Far End PE yield/cm	Required Min PE yield/cm	Needed Increase Factor	PE yield/cm		PE Threshold		Energy Threshold	
							Far	Near	Far	Near	Far	Near
Extra-Long	6.600	0.349	0.257	8.3	14.0	1.7	12	35	6	6	1.00	0.35
Long	5.600	0.397	0.293	9.4	14.0	1.5	14	35	7	7	1.00	0.40
Medium	4.500	0.462	0.341	11.0	14.0	1.3	16	35	8	8	1.00	0.46
Short	3.000	0.579	0.427	13.8	14.0	1.0	20	35	10	10	1.00	0.58
Cryo	0.900	0.836	0.616	19.9	14.0	0.7	29	35	15	15	1.00	0.83

- Use test-beam measurement of 31 PE/cm with 1.0 mm fiber
- Use ageing results from MINOS: 3%/year for 10 years
- Required PE yield/cm: 14
- Required energy threshold: 1 MeV
- Use measured 1.0 mm fiber attenuation length

Increasing Light Yield by Fiber Diameter

$$L = (-0.044 \pm 0.077) + (0.655 \pm 0.179)d + (0.355 \pm 0.099)d^2$$

$$L = 2.7 \rightarrow d = 2.01 \text{ mm}$$

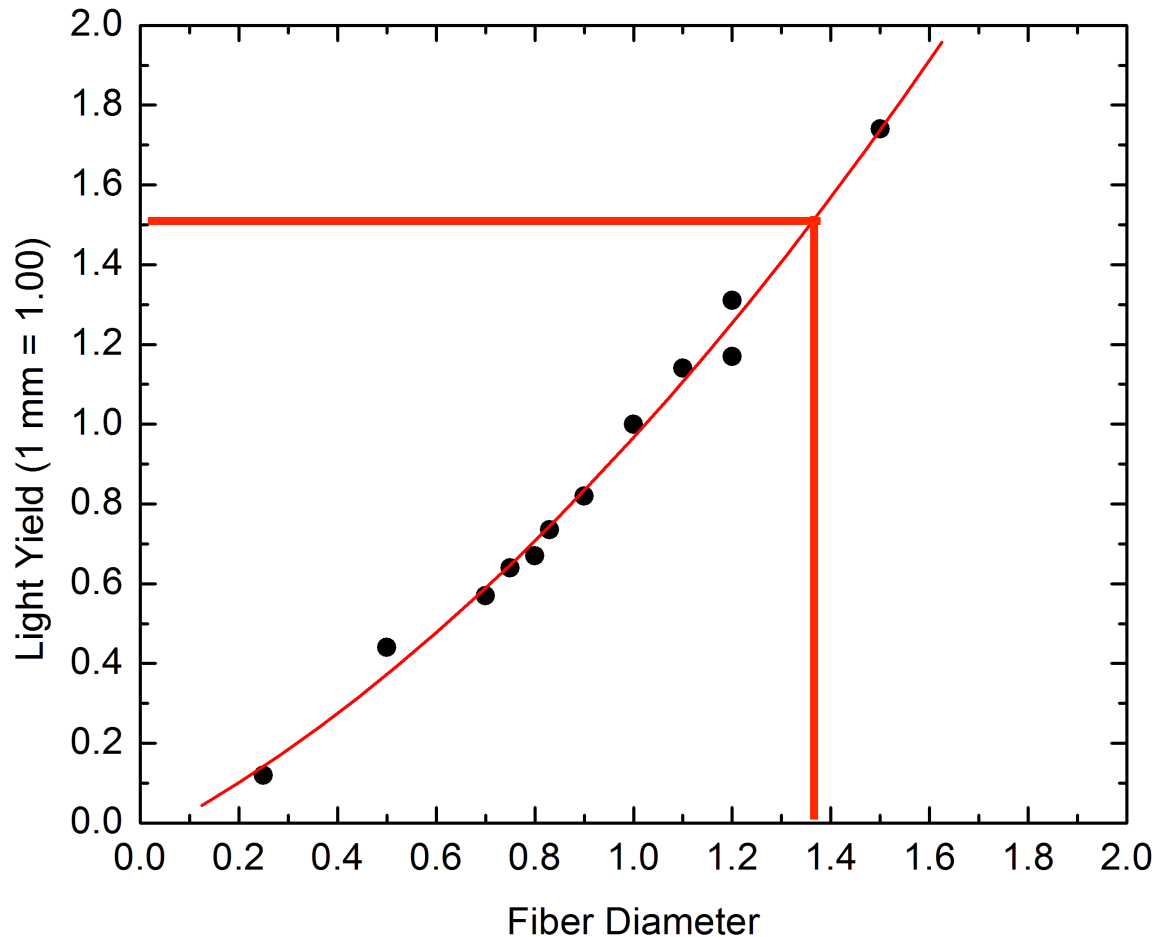

Tests done at Caltech and UMN (NUMI note 414)

Photoelectron Yield

- Prototype counters will be tested using cosmic-ray test stand being fabricated in Lab 6 using spare parts for CMS muon upgrade and BNL electronics designed for ATLAS
- Dubna group will commission chambers and write DAQ and tracking code

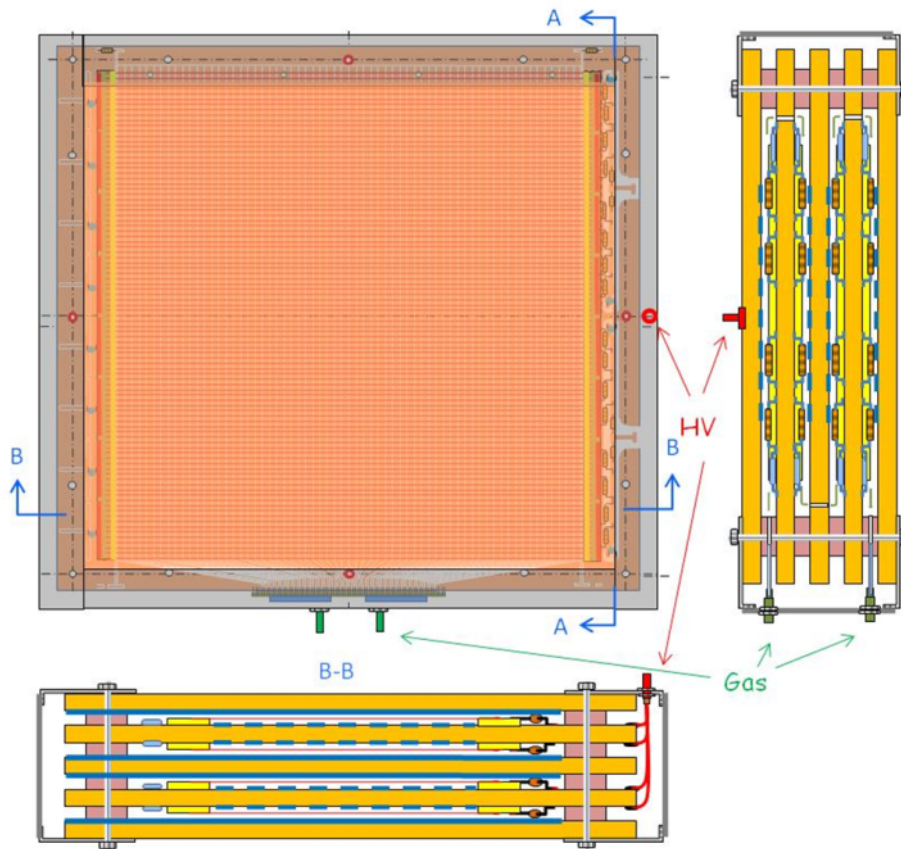

4 x, 4 y cathode strips
100 x 100 cm² area



Backgrounds: Neutron & Gammas

Simulations: Neutron/Gamma Backgrounds

- Neutron/gamma rate limits come from three sources:
 1. Damage to SiPMs: limit $< 1 \times 10^{10} \text{ n/cm}^2$
 2. Damage to front-end boards: limit $< 4 \times 10^{11} \text{ n/cm}^2$
 3. Unacceptably high false veto rate
- Neutron Working Group formed in summer of 2012 to address effect of neutrons on detectors in TS and DS regions
- Charge:
 - Find sources of neutrons
 - Determine their rates and energy spectrum
 - Find schemes by which they can be mitigated
- Work essentially complete for TDR design:
 - Need to compare deadtime from MARS and G4beamline
 - Need to perform non-factorized simulation with better CRV model

Simulations: Neutron/Gamma Backgrounds

TDR Geometry: Geometry-14d (G4beamline realization)

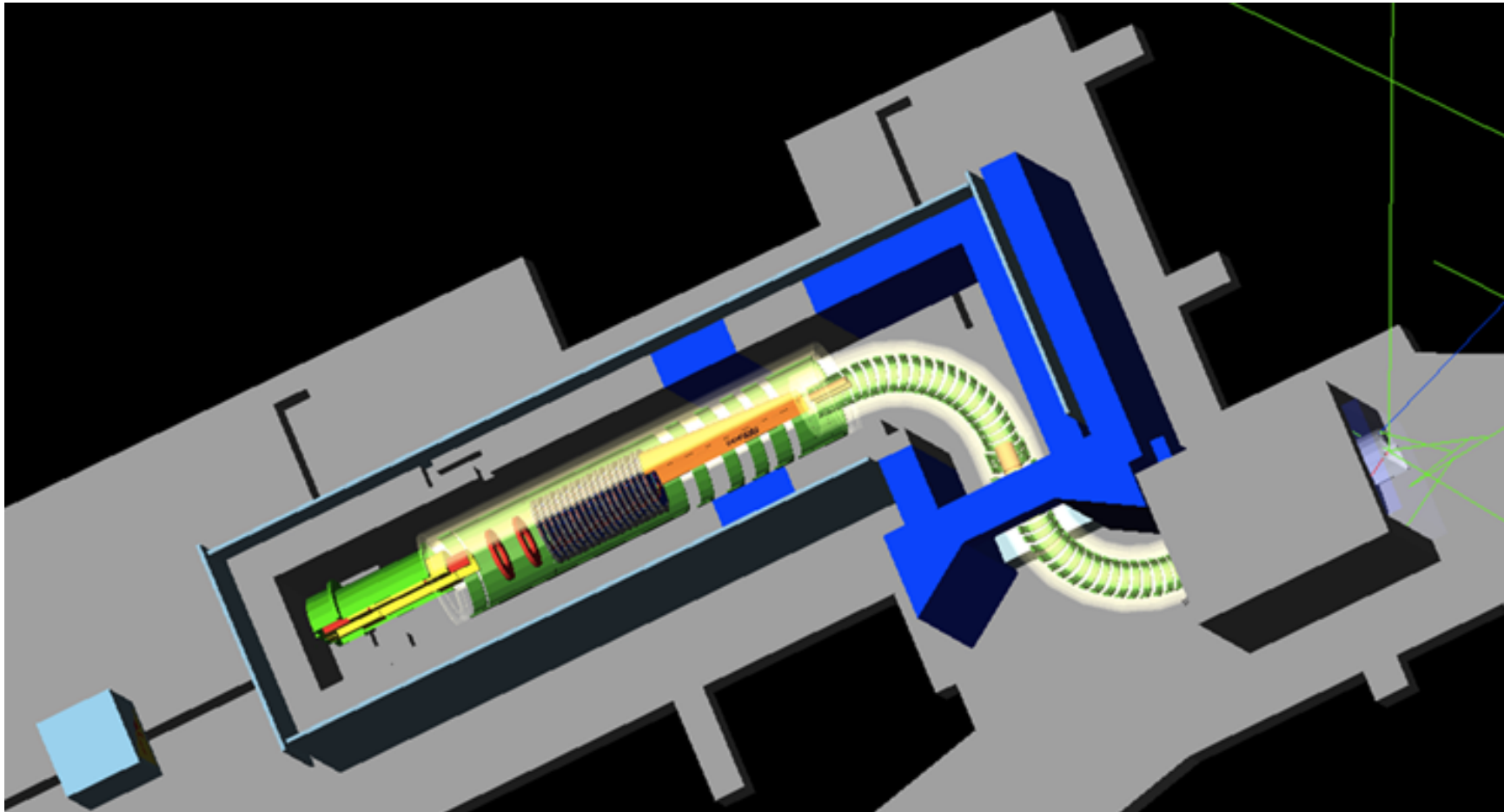

Simulations: Neutron/Gamma Backgrounds

- G4beamline used, but checked in places with MARS, GEANT4, and MCNP
- Factorized simulation:

G4beamline simulation of beam on production target produces PS (neutrons) and beam(charged particle) files.



Particles from PS and beam files, and whatever secondaries they produce, are tracked to the CRV, again using G4beamline.



Rates in CRV are found using efficiencies for neutrons and gammas determined using G4beamline, GEANT4, and MCNP

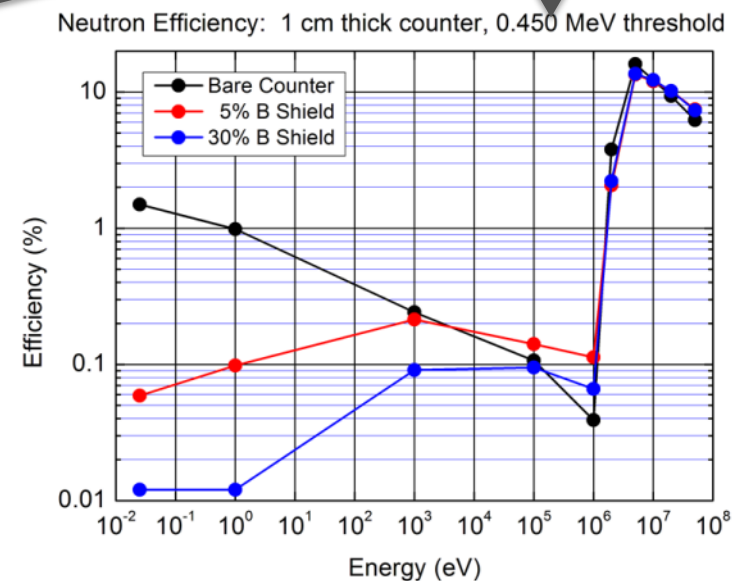
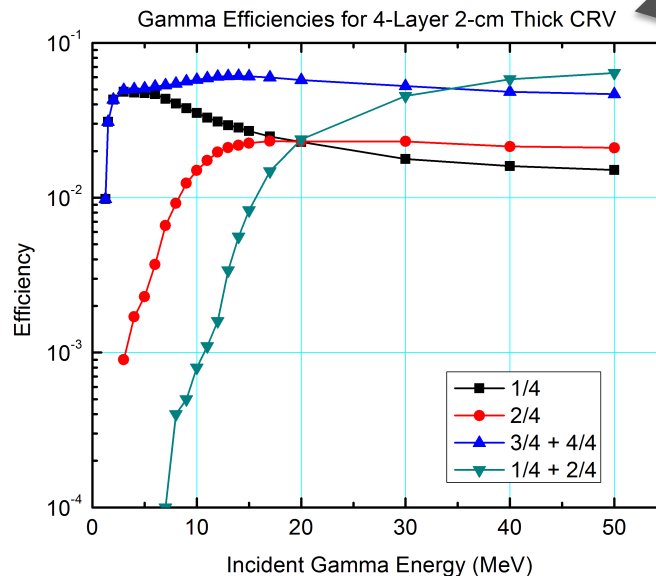

Backgrounds: Origin of Gammas + Neutrons

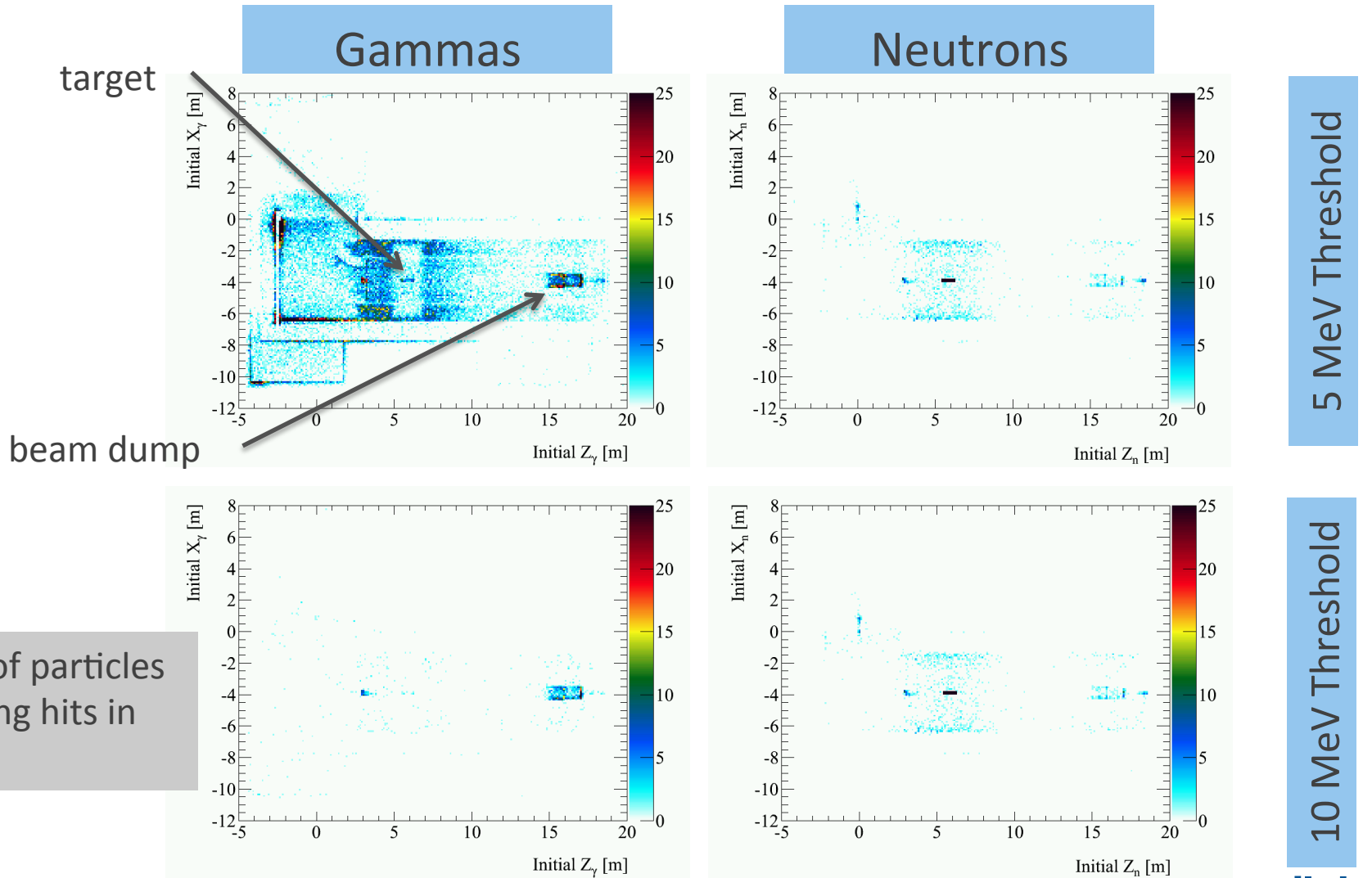

Mu2e



Backgrounds: Integrated Rates & Deadtime

- Simulations of the rates due to neutrons and gammas have been done using a G4beamline model of the apparatus, shielding, and beam
- Rates have been checked with MARS
- Factorized simulation: beam → secondary transport → rates using CRV efficiencies determined from G4beamline, GEANT4, and MCNP
- A full non-factorized simulation in the Mu2e framework is underway
- **The PE (energy) cut will be applied offline, not in real time**
- **The veto will be applied offline, not in real time**

Front-end hit threshold: a few PE	Threshold [MeV]	Max Instant Rate [kHz]	Average Rate [kHz]	Fractional dead time [%]
	0.1	685	127	100
Offline energy threshold	0.5	260	48	4.4
	1.0	160	30	1.2

Backgrounds: Radiation Damage

- Ionizing dose: not a problem for detector or electronics
- Non-ionizing dose: max. rate $< 10^{10}$ (1 MeV eq) n/cm² is on the edge of needing testing
- Will study performance of SiPMs and Front-end Boards at 10^{10} n/cm²

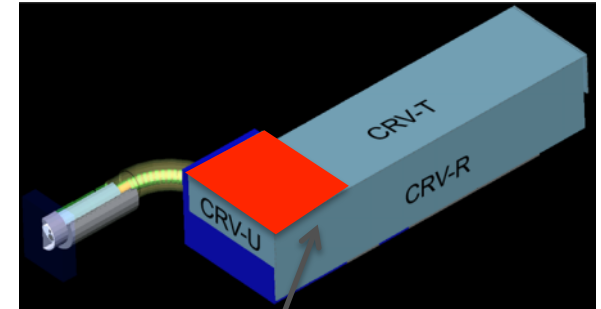

Readout at this end only

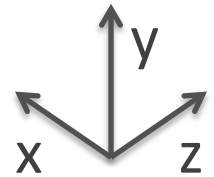

Ionizing Radiation Dose

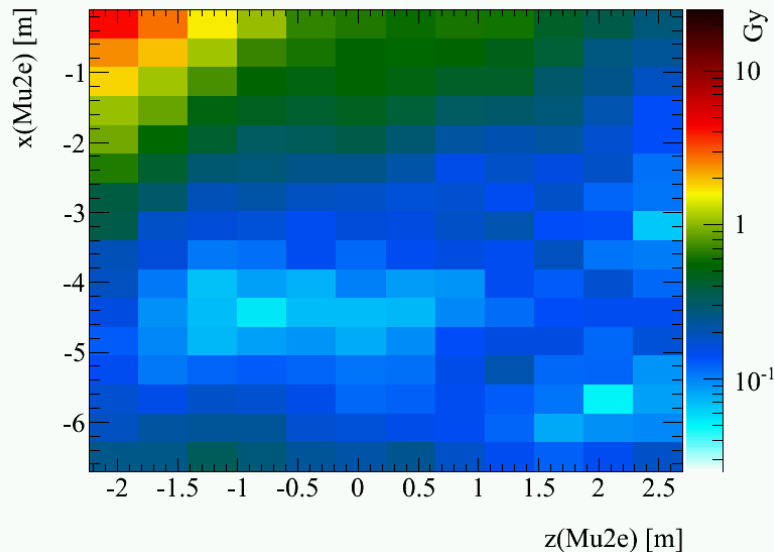

Neutron (1 MeV) fluence (cm⁻²)

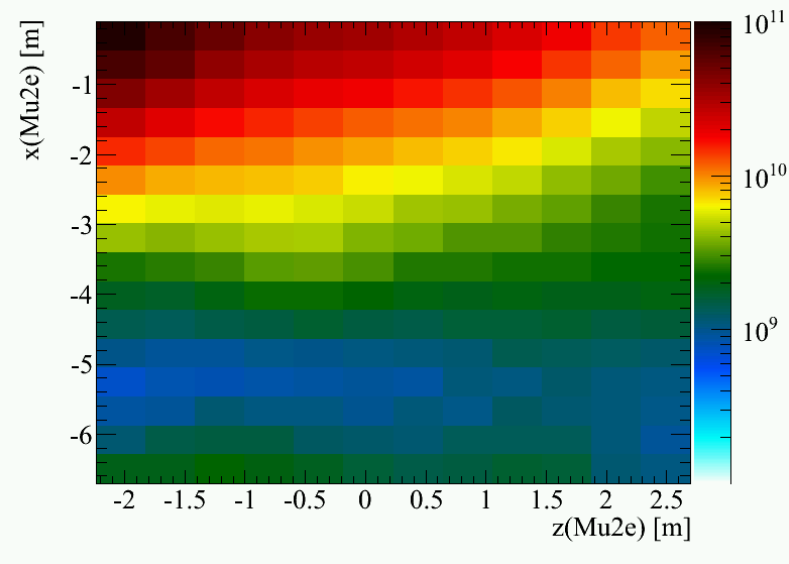

Mu2e



Changes since CD-1

- Simulations:
 - Rates: At CD-1 had no simulation, rather extrapolations from MECO design
 - Rates: Extensive simulations have shown that the rates from neutrons and gammas are over an order of magnitude higher than CD-1 estimates
 - Conversion Background: At CD-1 we had simulated 1.1×10^9 cosmic-ray muons; now 29×10^9 muons, and 100% of the total live time in certain regions.
- To mitigate the higher rates we have:
 - added shielding to the CD-1 design (see Muon Beamline WBS 475.5)
 - added an extra layer of counters ($2/3 \rightarrow 3/4$)
 - made the Al absorber layers thicker (to kill thru-going electrons)
- We have gone to a $50 \times 20 \text{ mm}^2$ extrusion profile: (1) Because of difficulties in extruding good quality, high-aspect ratio $100 \times 10 \text{ mm}^2$ extrusions, and (2) to increase the light yield (energy deposit) from muons traversing each layer.
- The standard module width reduced by $\sim 25\%$ to ease fabrication and handling.
- Decided to use a surface-mount SiPM
- Abandoned strongback design for all modules except those in CRV-U and CRV-L
- TS-L veto removed as it is not necessary

Remaining work before CD-3

- Design:
 - Complete design of module pivoter/installation jig
 - Design endcap CRV
 - Produce final engineering design
- Simulations:
 - Write real track-stub finding code
 - Perform non-factorized simulations in software framework to confirm work done on rates and radiation levels by the Neutron Working Group.
 - Complete the conversion-like electron background simulations: the goal is to simulate targeted areas with at least 10X the expected flux.
- Requirements:
 - Fabricate and measure PE yield of counter prototypes using baseline fiber, SiPMs, and extrusions. Use this to select the fiber size.
 - Measure neutron efficiency and use it to validate simulation code.

Value Engineering since CD-1

- We incorporate value engineering at every stage of design.
- We are investigating using wider (60-70 mm vs 50 mm) extrusions, which will lower the fiber/SiPM/electronics channel count and save costs. This is listed in the Risk Register as an opportunity.

Risks

There are no major cost or schedule risks

- More sophisticated simulations indicate higher rates
 - Risk: low
 - Mitigation: more shielding in targeted areas
- Simulations indicate that more CRV coverage needed
 - Risk: moderate
 - Mitigation: fabricate extra modules

Cost Table: Mechanical Design

	Base Cost (AY K\$)			Uncertainty (on remaining budget)	% Contingency (on remaining budget)	Total Cost
	M&S	Labor	Total			
8.02.01 Detector Design	65		65	9	54%	74
8.02.02 Fabricate and test Counter Prototypes	52	3	55	15	32%	70
8.02.03 Cosmic Ray Veto Simulations	18		18		-	18
Grand Total	135	3	138	24	38%	162

Note: Labor FNAL only.

Cost Breakdown: Sub-Project

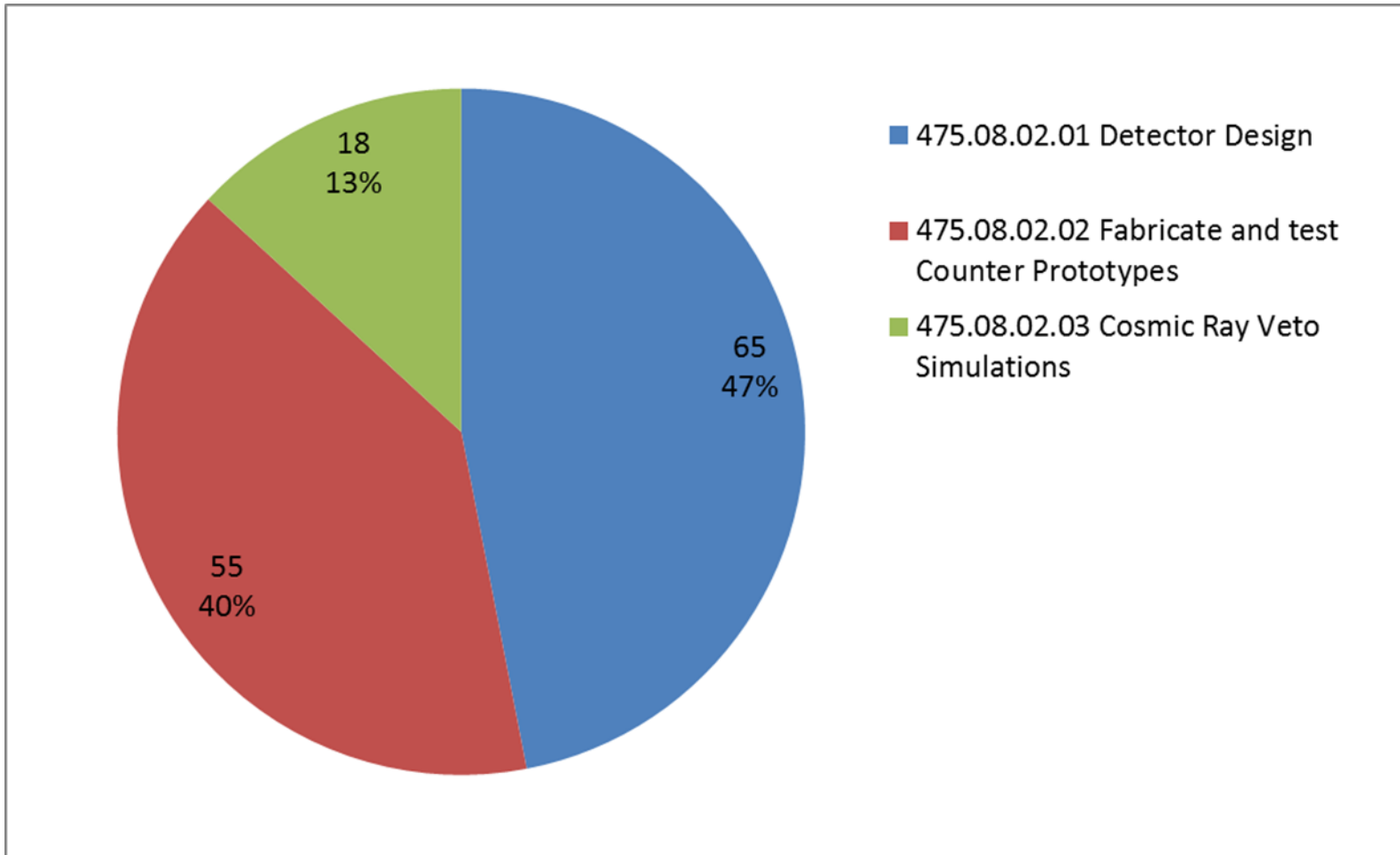

Cost Breakdown: Resource Type

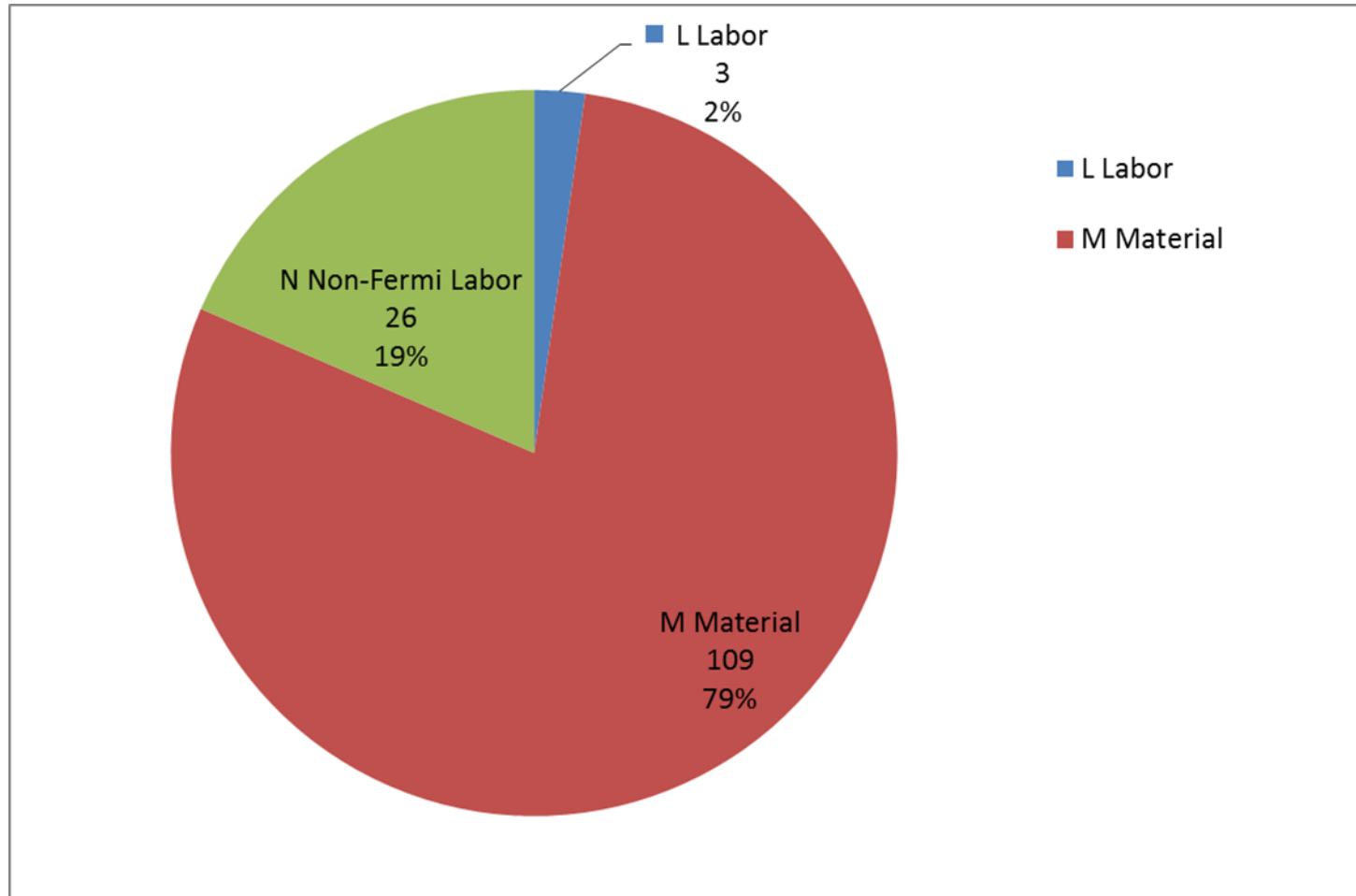

Quality of Estimate

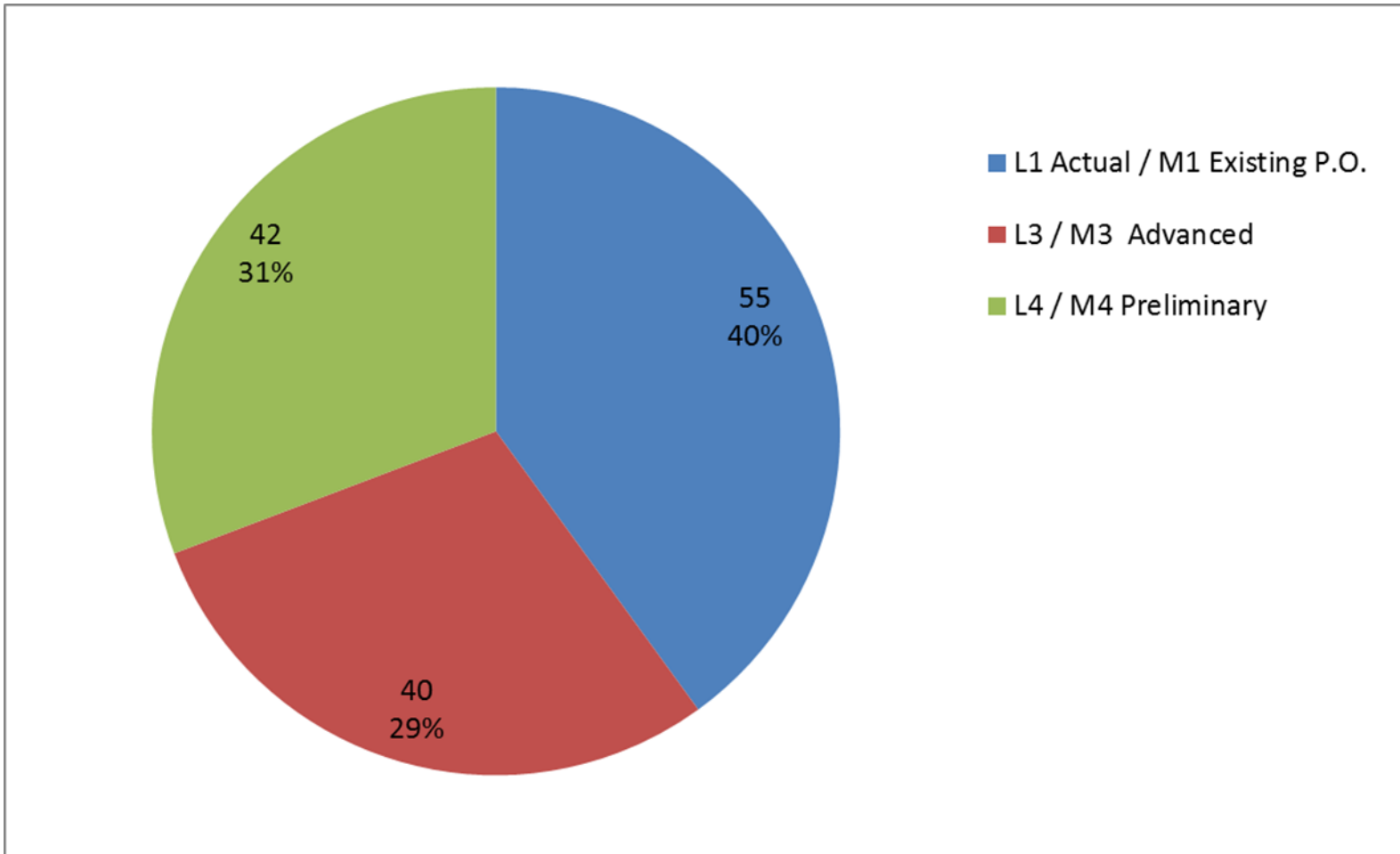

Labor Resources by FY

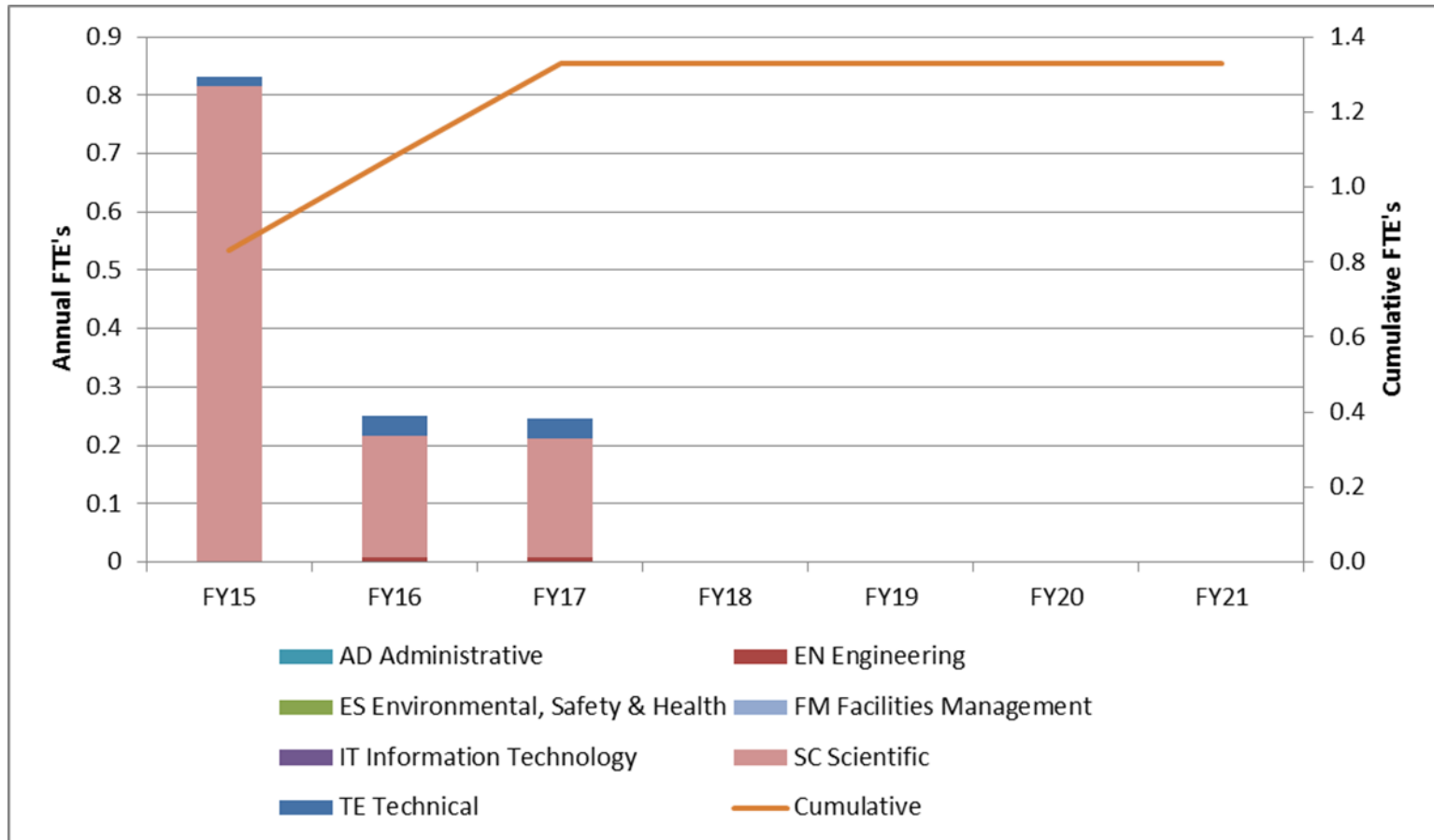

Major Milestones

Nov 2014: Preliminary engineering design complete

Oct 2015: Final pre-production design complete

Jan 2016: final engineering design complete

Schedule

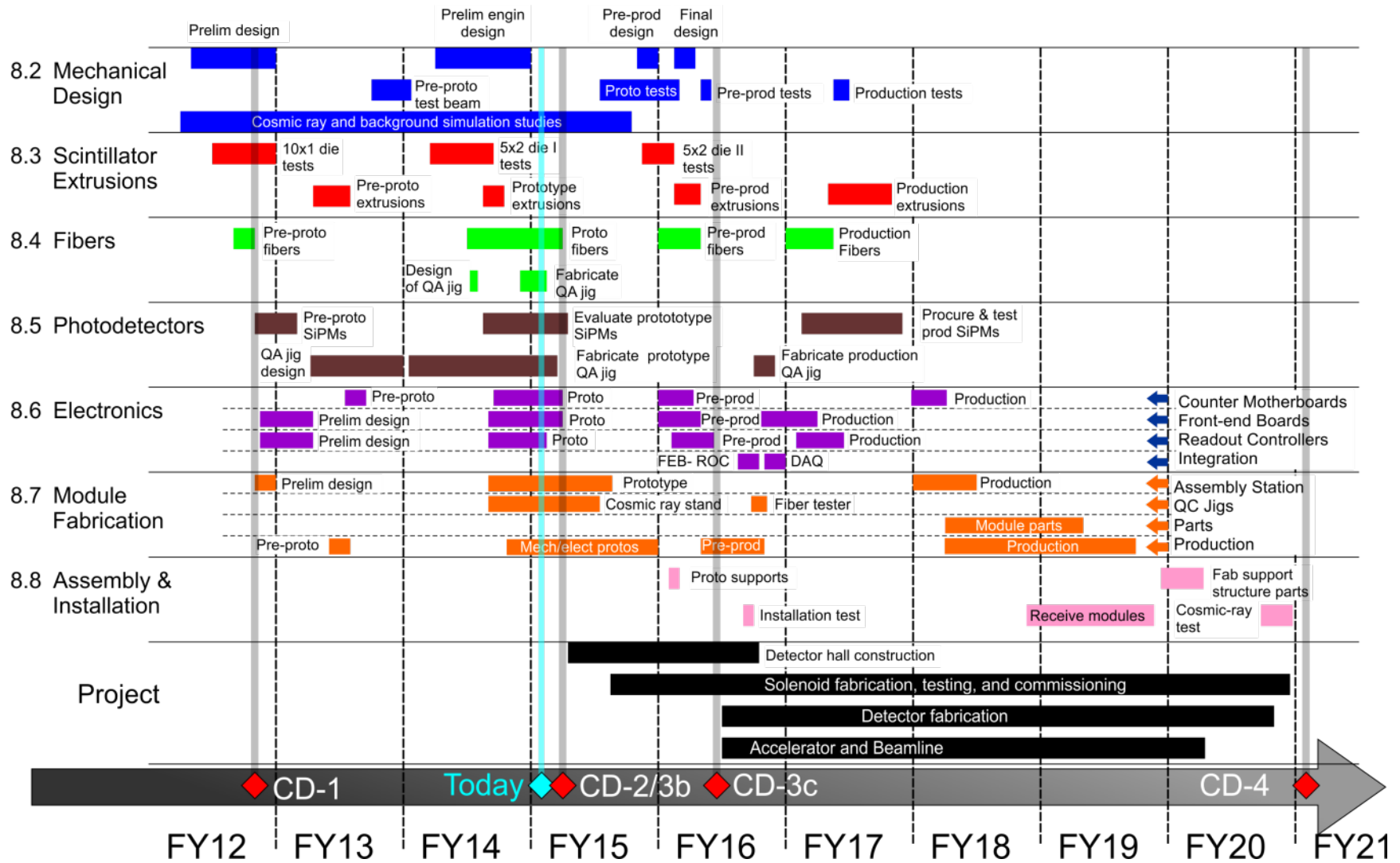

Summary

- We have a design that meets requirements, can be built, and is costed.
- The design is simple and relies on technologies that have been proven in several recent Fermilab experiments.
- The Cosmic Ray Veto sub-project is ready for approval of its performance baseline.