



LICARA –

Life cycle oriented guidelines for
the sustainable competitiveness of
nanoproducts

C. Som, I. Hincapie, C. Coll, R. Hischier, D. Notter, B.
Nowack, J. Güttinger, E. Zondervan, T. van Harmelen

Present situation for SMEs

Nanomaterials are expected to be key for the innovation

Open questions:

- Specific benefits of nanomaterials?
- Legal issues?
- Nanospecific risks for the environment and health?
- Environmental sustainability of nanoproducts?

- LCA and Risk assessment (RA) is too costly for SMEs
- Uncertainty about benefits and risks
- Information is fragmented and dispersed -> not available to SMEs

Goals of the project LICARA

Support for

1. the development of safe and sustainable nanoproducts
2. systematic and transparent assessment
3. documentation of benefits and risks of nanoproducts



Output of the project LICARA



NanoSCAN Tool (semi-quantitative)

LICARA Guidelines (qualitative)

LCA & RA (quantitative)

LICARA Guidelines and NanoSCAN

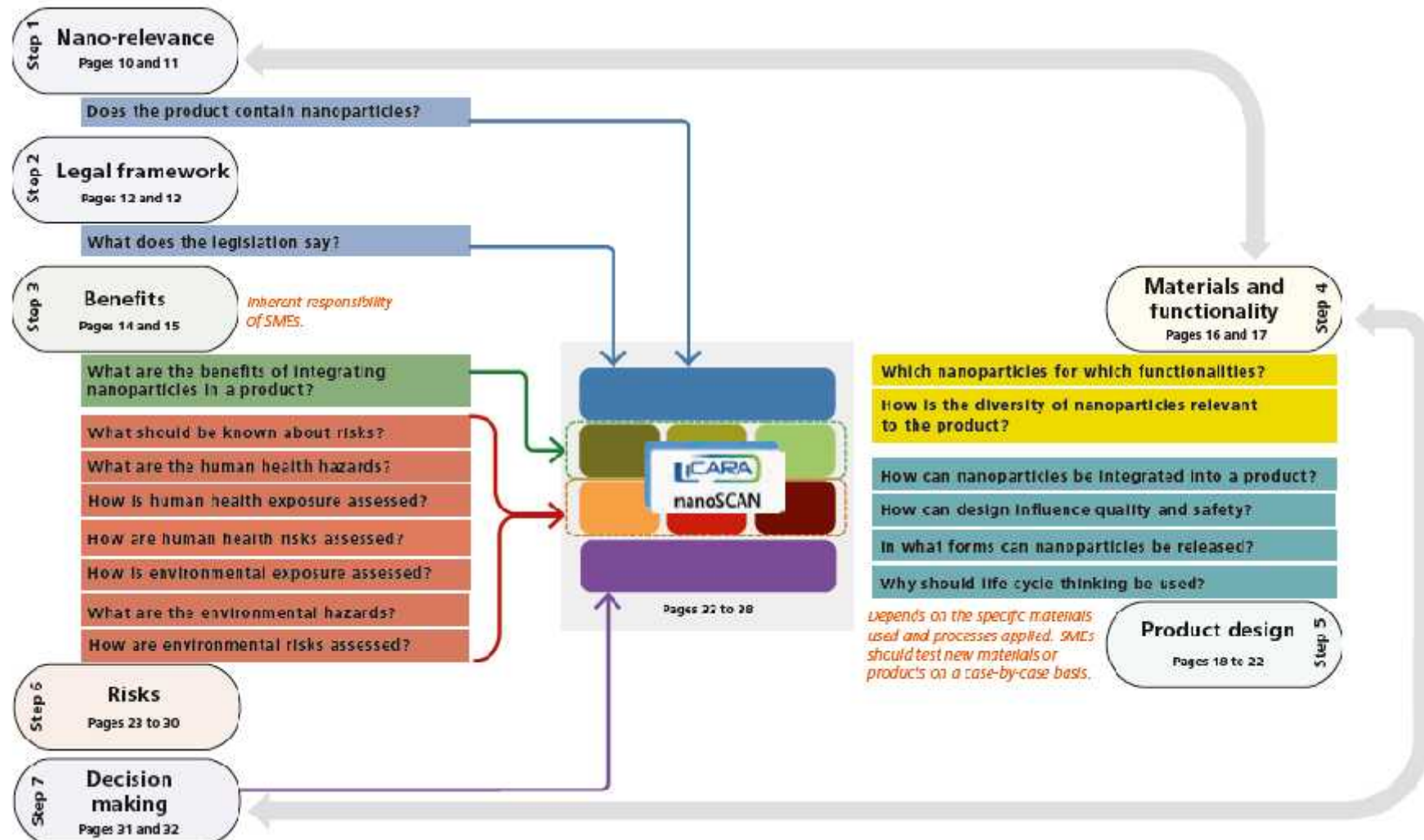

Content of the Guidelines

- **Proposal for a systematic proceeding** in order to assess benefits and risks of a nanomaterial or nanoproduct qualitatively.
- **Integrated knowledge about benefits and risks** based on the state of research and experience in the LICARA consortium
- **Interfaces** to the semi-quantitative NanoSCAN-Tool

Step 1: Nano-relevance

- Different Definitions of EU and ISO
- Sectorspecific definitions
- Definitions are still under development

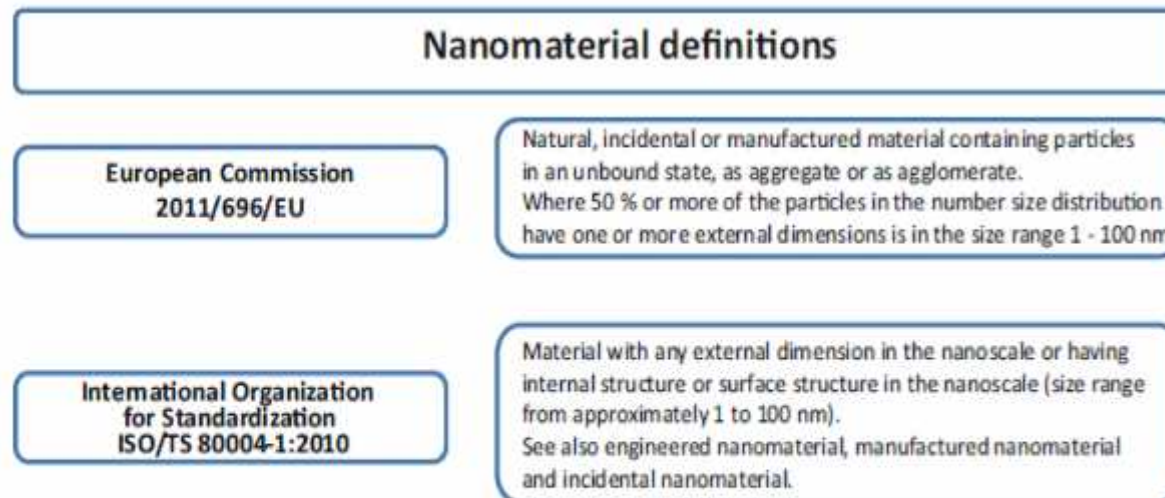

Apply Box 0 in the LICARA nanoSCAN to assess whether the product contains nanoparticles.

Step 2: Legal framework

Generic legislation

- › REACH (Registration, Evaluation, Authorization and Restriction of Chemicals)
 - › 31 May 2013 registration of chemicals above 100 tonnes
 - › 31 May 2017 registration of chemicals above 1 tonnes
 - › No specific nanoregistration
- › Chemical Agency Directive (CAD)
- › Classification, Labelling and packaging (CLP)
- › General Product Safety Directive (GSPD)

Specific legislation

- › e.g. cosmetics, biocides, food, food contact materials

These legislative aspects are dealt with in a very simple way in LICARA nanoSCAN Box 0.

Step 3: Benefits of nanomaterials

Integration of nanoparticles in products may lead to Improved:

Environmental performance:

- lighter materials (resource savings),
- resistant surfaces (prolonged product lifetime)

Economic performance:

- reduction of costs by e.g. easy handling, saving precious rare materials, materials savings)

Social performance:

- improved hygiene
- improved safety of products

Apply Boxes 1-3 in the LICARA nanoSCAN to assess whether the nanoparticles bring benefits to the product.

Step 4: Materials & functions

Nanoparticle type	Ag	ZnO	TiO ₂		Al ₂ O ₃	"nanoclay"	CB	CNT	MWCNT	SWCNT	Fe ₂ O ₃	ZrO ₂	CeO ₂	CuO	MgO/ Mg(OH)
			Anatase	Rutile											
Potential functional effects															
Abrasion resistance		✓	✓		✓	✓		✓							
Antimicrobial activity	✓	✓		✓	✓									✓	✓
Antislatic	✓						✓	✓	✓	✓					
Carrier of active agents			✓			✓									
Catalyst														✓	✓
Dirt repellent		✓	✓	✓											
Easy to clean				✓											
Electrical conductivity	✓						✓	✓							
Flame retardant		✓	✓	✓	✓	✓		✓	✓	✓					✓
High chemical resistance					✓										
Hydrophobic (water repellent)		✓	✓	✓	✓										
Hydrophillic			✓												
Magnetic											✓				
Mechanical (stiffness and hardness)			✓		✓			✓	✓	✓		✓	✓		
Optical (UV reflection)		✓			✓						✓		✓		
Photo catalytic activity		✓		✓	✓										
Pigment		✓		✓	✓		✓				✓				
Scratch resistance		✓			✓							✓	✓		
Self-cleaning	✓	✓	✓	✓	✓										
Thermal conductivity	✓							✓	✓	✓					
Thermal insulation		✓	✓	✓	✓			✓	✓	✓					

Step 5: Product - Design

"Stability factors"	Stability of NM in the matrix material	
	Tends to be higher	Tends to be lower
Compatibility between NM and their matrix material (fibre polymer, coating)	NPs exhibit high wettability	NPs exhibit low wettability
Location of NPs in the product	Fully embedded in the matrix	Exposed on the material surface
Bond between NPs and the matrix	Bonds are covalent	Bonds are non-covalent
Intrinsic properties of the NPs: <ul style="list-style-type: none"> • photocatalytic activity of NPs • stability of NPs against aging 	Not photocatalytic High stability	Photocatalytic Low stability
Resistance of matrix material to abrasion or chemical attack	Resistant	Not resistant
Mechanical properties of the matrix material	flexible	brittle
Functional barrier (e.g. coating, plastic layer)	Functional barrier is present	Functional barrier is absent
Closed systems, e.g. fuel cells, batteries, solar cells.	System is fully contained	System is not contained

Step 6: Risk

What is the risk?



Low risk:
low hazard,
high exposure



Low risk:
high hazard,
low exposure



HIGH RISK:
high hazard,
high exposure!

Step 6: Health effects

Hazard potential	Ag	ZnO	TiO ₂	SiO ₂ amorphous	Al ₂ O ₃	Nano-clay	CNT		CB
							Rigid	Flexible	
Acute toxicity									
- via inhalation	-/+	-	-	-/+	-/+	n.a.	-/+*	-/+*	n.a.
- via ingestion	-	-	-	-	-	-	n.a.	-	-
- via skin contact	-	-	-	-	n.a.	n.a.	n.a.	-	n.a.
Mutagenicity	-	-	-	-/+	-/+	n.a.	-	-	+
Chronic toxicity (expected long-term effects)									
- via inhalation	+	+	+	+	-/+	n.a.	++	+	++
- via ingestion	-/+	-/+	-	-	-/+	-	n.a.	n.a.	-
- via skin contact	-	n.a.	-	-	n.a.	n.a.	n.a.	n.a.	-

++ high toxicity, + medium toxicity, +/- weak evidence for toxicity – low toxicity n.a. no data available

Step 6: Exposure, release

Nano- related activity	Potential human exposure	Risk Management Measures for reducing exposure
Spraying nano-enabled coatings	High	Ventilated spraycabin Face mask
Handling large amounts of powdered nanomaterial	High	Enclosed systems Ventilation Face mask
Batch mixing of powdered nanomaterial with liquid	Medium	Enclosed system Reduce mixing speed Ventilation Face mask
Handling small amounts of powdered nanomaterial	Low	Enclosed systems Ventilation Face mask
Brushing nano-enabled coatings	Low	N/A
Careful use of a solid nano-enabled products	Low	N/A

Apply Boxes 4-6 in the LICARA nanoSCAN to assess the human health risks posed by the nanoprodukt.

Step 6: Behaviour of nanomaterials in technical systems

Wastewater treatment plants	In general, the vast majority (around 95%) of nanomaterials are removed from water and end up in sludge. Applying sewage sludge to soils represents one of the major flows of nanomaterials into the environment
Waste incineration plants	European waste incineration plants are equipped with flue gas cleaning systems that remove the vast majority (>99.9%) of the nanoparticulate fraction. Nanomaterials therefore end up in filter ash or bottom ash and subsequently go to landfill
Landfills	The behaviour of nanomaterials in landfills is so far unknown
Recycling	No data are as yet available about the fate of nanomaterials during recycling, but it is expected that release may occur to some extent during recycling operations as product matrices may be destroyed

Step 6: Relative environmental risks

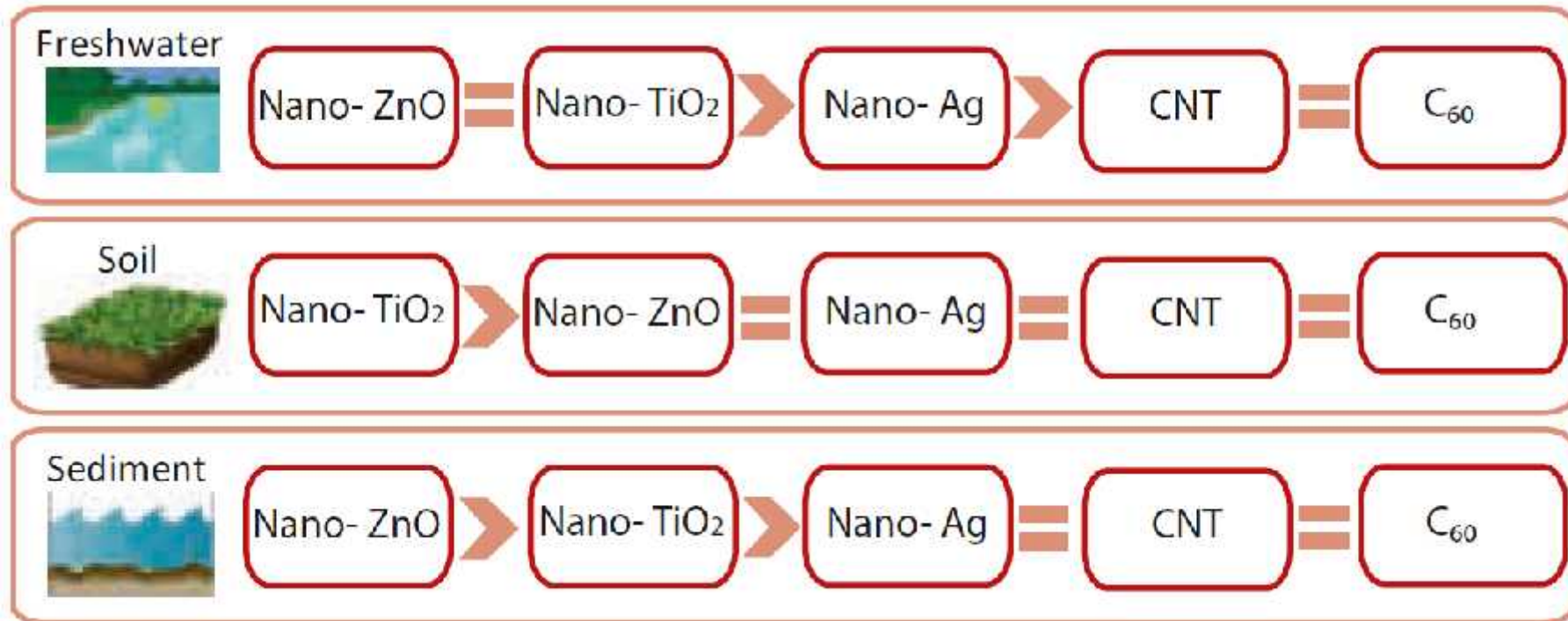

Apply Box 4 in the LICARA nanoSCAN to assess the environmental risks posed by the nanoproducts.

Step 7: Decision making

Life cycle thinking

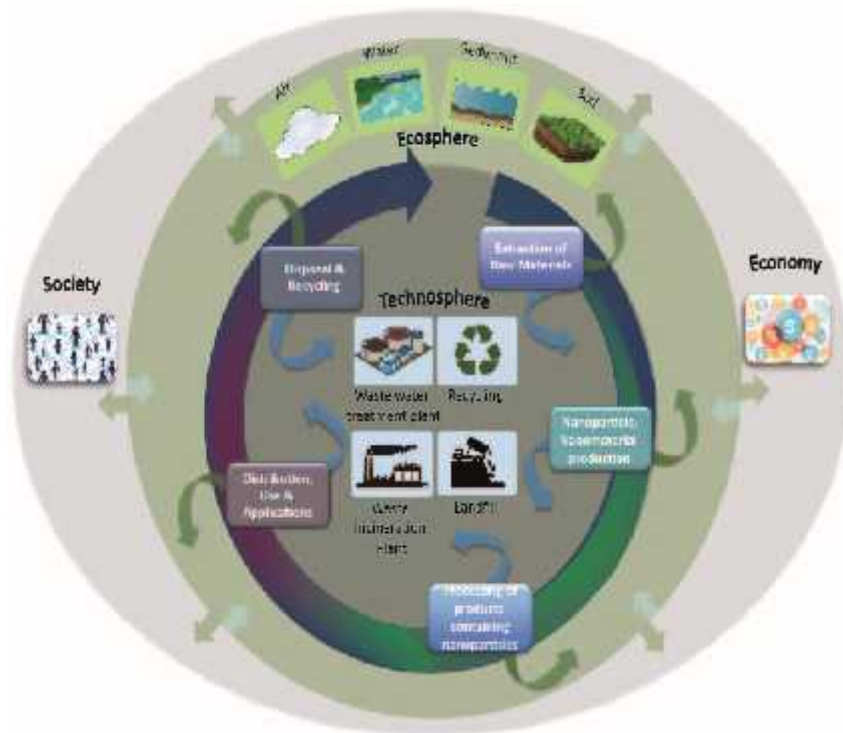

- Identify opportunities to increase benefits (e.g. material and energy savings) and innovation
 - Select nanomaterials, functions and product design to minimize the risks and optimize the benefits during the whole product life cycle.
- Hedge against misinvestments
- Comply with regulations
- Gain competitive advantage

Apply Box 7 in the LICARA nanoSCAN facilitates decision making on the nano-products.



LICARA NanoSCAN

0. Nanoproduct and legislation

1. Environmental benefits

2. Economic benefits

3. Societal benefits

4. Public health environmental risks of nano

5. Occupational health risks of nano

6. Consumer health risks of nano

Precautionary Matrix

7

Stoffenmanager Nano

NanoRiskCat

1. Environmental benefits

Environmental impacts in different life cycle phases

- › Manufacturing
- › Use phase
- › End-of-life

1. Environmental benefits [-1..1]	0.57
Manufacturing	0.04
Use	0.92
End-of-life	0.75

7. Decision support

Case: self cleaning nano TiO₂ façade coating

The product has the following high risks:

Occupational health;

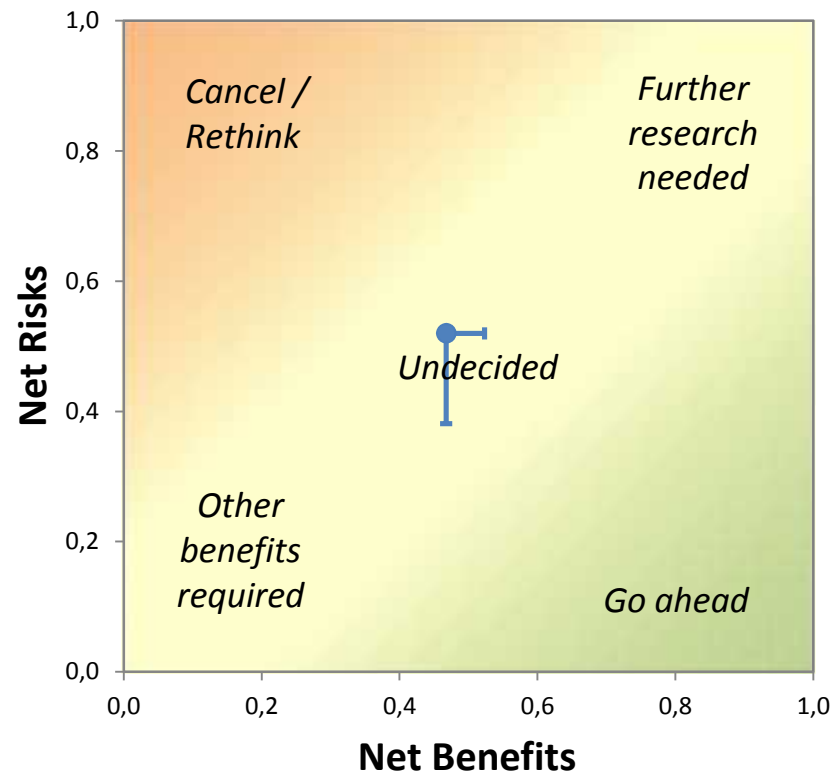



SUN-SNO-GUIDENANO Sustainable Nanotechnology Conference, Mar 9., 2015, Venice

Thank you for your attention

Thanks to the LICARA consortium and EU FP7,
I. Linkov, J. Höck, T. Walser,
D. Hart (proof reading)

